AMPLATCH* System 50 Connector Receptacle and Paddleboard

SCOPE

1.1. Content

This specification covers performance, tests and quality requirements for AMPLATCH* System 50, .025 inch centerline, flat cable round conductor connector receptacle and paddleboard. Although not specifically tested, paddleboard is considered qualified to this specification due to its identical termination slot design including slot width, length, material thickness, and all other dimensions in the wire termination area. These connectors are defined as follows: receptacle contacts crimped to .025 inch centerline ribbon cable having 30 AWG solid, 30 AWG stranded, or 32 AWG stranded conductors. Complete receptacle assemblies mate to .015 inch square or round posts on an .050 X .100 inch grid pattern with equivalent post length of .125+ .010 inch. Complete paddleboard assemblies are soldered directly to a printed circuit board.

1.2. Qualification

When tests are performed on the subject product line, procedures specified in Figure 1 shall be used. All inspections shall be performed using the applicable inspection plan and product drawing.

1.3. Qualification Test Results

Successful qualification testing on the subject product line was completed on 30Oct01. The Qualification Test Report number for this testing is 501-189. This documentation is on file at and available from Engineering Practices and Standards (EPS).

2. APPLICABLE DOCUMENTS

The following documents form a part of this specification to the extent specified herein. Unless otherwise specified, the latest edition of the document applies. In the event of conflict between the requirements of this specification and the product drawing, the product drawing shall take precedence. In the event of conflict between the requirements of this specification and the referenced documents, this specification shall take precedence.

2.1. TE Connectivity (TE) Documents

- 109-197: TE Test Specifications vs EIA and IEC Test Methods
- 114-25029: Application Specification
- 114-25040: Application Specification
- 501-189: Qualification Test Report

2.2. Commercial Standard

EIA-364: Electrical Connector/Socket Test Procedures Including Environmental Classifications

3. REQUIREMENTS

3.1. Design and Construction

Product shall be of the design, construction and physical dimensions specified on the applicable product drawing.

3.2. Materials

Materials used in the construction of this product shall be as specified on the applicable product drawing.

3.3. Ratings

- Voltage: 30 volts AC
- Current: Signal application only, 0.5 ampere maximum per single circuit
- Temperature: -65 to 105°C

3.4. Performance and Test Description

Product is designed to meet the electrical, mechanical and environmental performance requirements specified in Figure 1. Unless otherwise specified, all tests shall be performed at ambient environmental conditions per EIA-364.

3.5. Test Requirements and Procedures Summary

Test Description	Requirement	Procedure
Initial examination of product.	Meets requirements of product drawing.	EIA-364-18. Visual and dimensional (C of C) inspection per product drawing.
Final examination of product.	Meets visual requirements.	EIA-364-18. Visual inspection.
ELECTRICAL		
Low level contact resistance.	30 milliohms maximum.	EIA-364-23. Subject specimens to 100 milliamperes maximum and 20 millivolts maximum open circuit voltage. See Figure 3.
Insulation resistance.	5000 megohms minimum.	EIA-364-21. Test between adjacent contacts of unmated and unterminated contacts within a row.
Withstanding voltage.	1 minute hold with no breakdown or flashover.	EIA-364-20, Condition I. 200 volts AC at sea level. Test between adjacent contacts of unterminated specimens.
MECHANICAL		
Vibration, sinusoidal.	No discontinuities of 1 microsecond or longer duration. See Note.	EIA-364-28, Test Condition III. Subject mated specimens to 10-2000-10 Hz traversed in 15 minutes with 1.5 mm [.06 in] maximum total excursion. 4 hours in each of 3 mutually perpendicular planes. See Figure 4.

Figure 1 (continued)

Test Description	Requirement	Procedure
Mechanical shock.	No discontinuities of 1 microsecond or longer duration. See Note.	EIA-364-27, Method A. Subject mated specimens to 50 G's half-sine shock pulses of 11 milliseconds duration. 3 shocks in each direction applied along 3 mutually perpendicular planes, 18 total shocks. See Figure 4.
Durability (receptacles).	See Note.	EIA-364-9. Mate and unmate specimens for 150 cycles at a maximum rate of 150 cycles per hour.
Mating force (receptacles).	1.11 N [4 oz] maximum per contact.	EIA-364-13. Measure force necessary to mate specimens at a maximum rate of 12.7 mm [.5 in] per minute.
Unmating force (receptacles).	0.14 N [.5 oz] minimum per contact.	EIA-364-13. Measure force necessary to unmate specimens at a maximum rate of 12.7 mm [.5 in] per minute.
ENVIRONMENTAL		
Thermal shock.	See Note.	EIA-364-32, Test Condition II. Subject unmated specimens to 5 cycles between -65 and 105°C.
Humidity-temperature cycling.	See Note.	EIA-364-31, Method III. Subject unmated specimens to 10 cycles (10 days) between 25 and 65°C at 80 to 100% RH.
Temperature life.	See Note.	EIA-364-17, Method A, Test Condition 4, Test Time Condition C. Subject mated and terminated specimens to 105°C for 500 hours.
Mixed flowing gas (receptacles).	See Note.	EIA-364-65, Class II. Subject mated specimens to environmental Class II for 20 days.

NOTE

Shall meet visual requirements, show no physical damage, and meet requirements of additional tests as specified in the Product Qualification and Requalification Test Sequence shown in Figure 2.

Figure 1 (end)

3.6. Product Qualification and Requalification Test Sequence

Test or Examination	Test Group (a)			
	1	2	3	4(b)
	Test Sequence (c)			
Initial examination of product	1	1	1	1
Low level contact resistance	3,7	2,5	2,5	
Insulation resistance				2,6
Withstanding voltage				3,7
Vibration	5			
Mechanical shock	6			
Durability	4	3(d)	3(d)	
Mating force	2			
Unmating force	8			
Thermal shock				4
Humidity-temperature cycling				5
Temperature life		4(d)		
Mixed flowing gas			4(d)	
Final examination of product	9	6	6	8

- NOTE**
- (a) See paragraph 4.1.A.
 - (b) Test group is unmated and unterminated.
 - (c) Numbers indicate sequence in which tests are performed.
 - (d) Precondition specimens with 10 durability cycles.

Figure 2

4. QUALITY ASSURANCE PROVISIONS

4.1. Qualification Testing

A. Specimen Selection

Specimens shall be prepared in accordance with applicable Instruction Sheets and shall be selected at random from current production. All test groups shall consist of a minimum of 5 connectors. A minimum of 6 contact circuits in each connector shall be randomly selected and identified. Unless otherwise specified, these contacts shall be used for all measurements.

B. Test Sequence

Qualification inspection shall be verified by testing specimens as specified in Figure 2.

4.2. Requalification Testing

If changes significantly affecting form, fit or function are made to the product or manufacturing process, product assurance shall coordinate requalification testing, consisting of all or part of the original testing sequence as determined by development/product, quality and reliability engineering.

4.3. Acceptance

Acceptance is based on verification that the product meets the requirements of Figure 1. Failures attributed to equipment, test setup or operator deficiencies shall not disqualify the product. If product failure occurs, corrective action shall be taken and specimens resubmitted for qualification. Testing to confirm corrective action is required before resubmittal.

4.4. Quality Conformance Inspection

The applicable quality inspection plan shall specify the sampling acceptable quality level to be used. Dimensional and functional requirements shall be in accordance with the applicable product drawing and this specification.

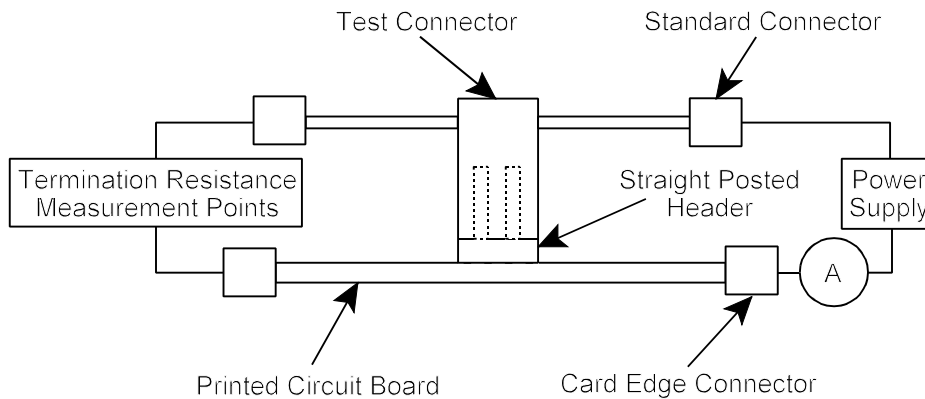

NOTE *No straight posted header is required with Paddleboard which solders directly to the printed circuit board.*

Figure 3
Low Level Contact Resistance Measurement Points

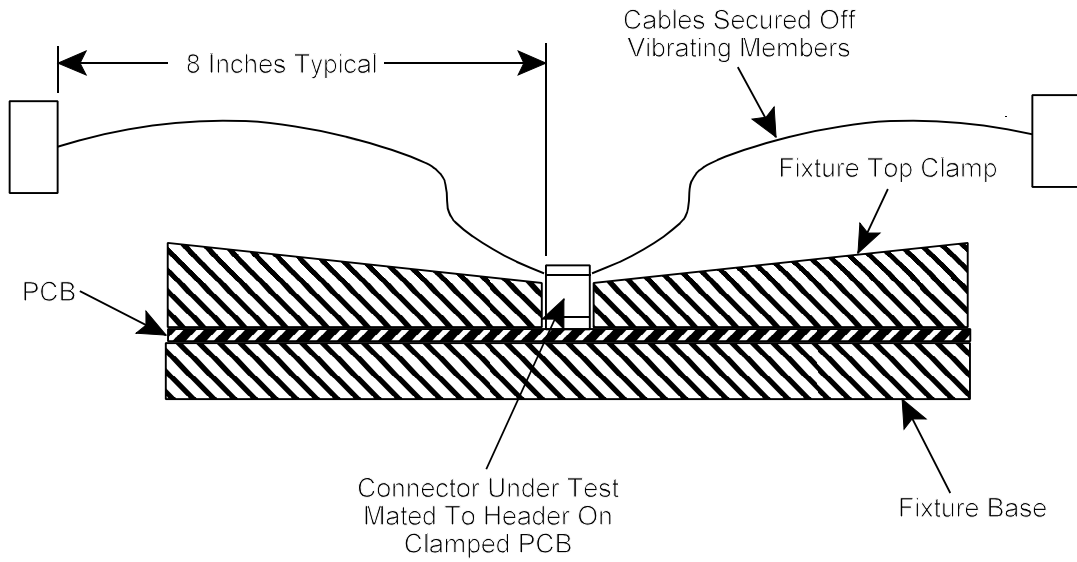

NOTE *No straight posted header is required with Paddleboard which solders directly to the printed circuit board.*

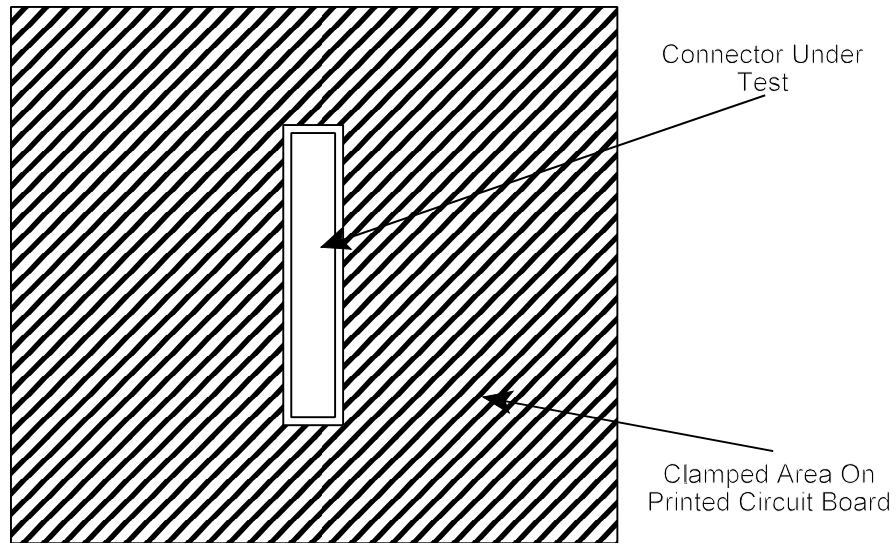

Figure 4
Vibration & Mechanical Shock Mounting Fixture