

Product Specification

108-5525

AMP Mini Common Termination (CT) Connector 1.5mm Pitch (MT Type)

1. Scope:

1.1 Contents:

This specification covers the requirements for product performance, test methods and quality assurance provisions of AMP Mini Common Termination (CT) Connector 1.5mm Pitch (MT Type). Applicable product description and part numbers are as shown in Fig.1.

2. Applicable Documents:

The following documents form a part of this specification to the extent specified herein. In the event of conflict between the requirements of this specification and the product drawing, the product drawing shall take precedence. In the event of conflict between the requirements of this specification and the referenced documents, this specification shall take precedence.



2.1 AMP Specifications:

- A. 109-5000 : Test Specification, General Requirements for Test Methods
- B. 114-5223 : Application Specification
- C. 501-5269 : Test Report

2.2 Commercial Standards and specifications :

- A. MIL-STD-202 : Test Methods for Electronic and Electrical Component Parts.
- B. IEC : International Electrotechnical Commission

THIS INFORMATION IS CONFIDENTIAL AND IS DISCLOSED TO YOU ON CONDITION THAT YOU WILL NOT DISCLOSE OR REPRODUCE IT IN ANY MANNER TO OTHER THAN AMP PERSONNEL WITHOUT WRITTEN AUTHORIZATION FROM AMP SHANGHAI LTD

				DR	 Tyco Electronics AMP Shanghai Ltd.			
				H.Hoshino				
				CHK	 Tyco Electronics AMP Shanghai Ltd.			
				J.Tanigawa				
				APP	NO	108-5525	REV	LOC
				S.Kubouchi		G	ES	
	G	REVISIED	C.Z	12DEC	PAGE 1 of 17			
		D20051225211245_409482		05				
DIST	LTR	REVISION RECORD	DR	DATE				

3. Requirements:

3.1 Design and Construction:

Product shall be of the design, construction and physical dimensions specified on the applicable product drawing.

3.2 Materials:

A. Receptacle Assembly

Contact: Pre tin plated Phosphor Bronze

(0.8µm min.thick pre tin plated over 0.5µm min.thick copper underplate)

Housing : 66 Nylon G.F.(UL94V-O)

B. Single Row Post Header Assembly Vertical(V) Horizontal(H)

Double Row Post Header Assembly Vertical(V) Horizontal(H)

DIP Type

Post : Pre tin-Lead plated Brass

(0.8µm min. thick tin-lead plating over 0.5µm min.thick copper underplating)

Housing : 66 Nylon G.F.(UL94V-O)

C. Single Row, Double Row Post Header Assembly Vertical(V) SMT Type

Post : Pre tin-Lead plated Brass (0.8µm min .thick tin-lead plating over 0.5µm min.thick copper underplating)

Housing : 6T Nylon G.F.(UL94V-O)

D. Single Row Post Header Assembly

Horizontal (H) SMT Type

Post : pre tin-Lead plated Brass

(0.8µm min .thick tin-lead plating over 0.5µm min.thick copper underplating)

Solder Peg: Tin-lead plated Brass

(3µm min thick tin-lead plating over 3µm min.thick copper underplating)

Housing : 6T Nylon G.F.(UL94V-O)

E. Single Row,Double Row Post Header Assembly Rellay Panel Mount Type.

Post : Pre tin-Lead plated Brass

(0.8µm min .thick tin-lead plating over0.5µm min.thick copper underplating)

Housing : 66 Nylon NON G.F.(UL94V-O)

F. Holder Housing for Double Row

Housing : 66 Nylon NON G.F.(UL94V-O)

3.3 Ratings:

- A. Voltage Rating :50 VAC/DC
- B. Current Rating(Maximum)
AWG #26 :2A, AWG #28 :1A
- C. Temperature Rating : -30°C to +105°C
The upper limit of the temperature includes the temperature rising resulted by the energized electrical current.

3.4 Applicable Wires

- A. Applicable Wire Size:
AWG #28,#26 (0.08 ~0.14mm²)
- B. Applicable Insulation Diameter
Harness Condition (Refer Fig.14)

	A-Side	B-Side	Insulation Diameter
1)	Mini CT	Mini CT	Φ0.8~0.95mm
2)	Mini CT	CT	Φ0.83~0.95mm

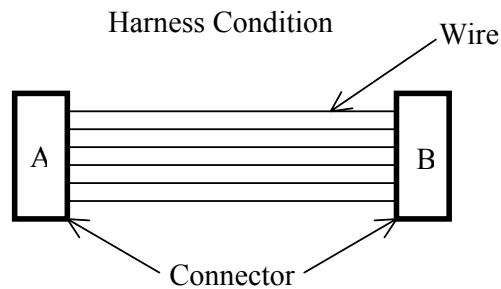

3.5 Applicable Printed

- A. Board Thickness 1.6mm
- B. Hole Diameter
φ0.85 ~φ0.95(for punched holes)
φ0.95 ~φ1.00(for drilled holes)

3.6 Applicable Panel Thickness

0.8 ~1.6mm (To be used for post header assembly relay)

3.7 Performance Requirements and Test Descriptions :

The product shall be designed to meet the electrical, mechanical and environmental performance requirements specified in Fig.2.

All tests shall be performed in the room temperature, unless otherwise specified.

tyco Electronics	Tyco Electronics AMP Shanghai Ltd.	PAGE 3 of 17	Document No. 108-5525	REV A	LOC ES
----------------------------	---	------------------------	--------------------------	----------	-----------

3.8 Test Requirements and Procedures Summary:

Para.	Test Items	Requirements	Procedures
3.8.1	Examination of Product	Meets requirements of product drawing and AMP Specification 114-5223.	Visual inspection No physical damage
Electrical Requirements			
3.8.2	Termination Resistance (Low Level)	10 mΩMax. (Initial) 20 mΩMax. (Final)	Subject mated contacts assembled in housing to 20 mV Max open circuit at 10 mA. Fig.4.
3.8.3	Dielectric withstanding Voltage	No creeping discharge nor flashover shall occur. Current leakage : 5 Ma Max.	500 VAC for 1 minute. Test between adjacent circuits of mated connectors. MIL STD 202 TEST METHOD 301
3.8.4	Insulation Resistance	500 MΩMin. (Initial) 100 MΩMin. (Final)	Impressed voltage 500 VDC for 1 minute. Test between adjacent circuits of mated connectors. MIL STD 202 TEST METHOD 302 CONDITION A
3.8.5	Temperature Rising	30 °C Max. under loaded rating current.	Contacts series-wired, apply test current of loaded rating current to the circuit, and measure the temperature rising by probing on soldered areas of contacts, after the temperature becomes stabilized Deduct ambient temperature from the measured value. Fig.4

Fig. 2 (To be continued)

tyco Electronics	Tyco Electronics AMP Shanghai Ltd.	PAGE 4 of 17	Document No. 108-5525	REV A	LOC ES
----------------------------	---	------------------------	---------------------------------	-----------------	------------------

Para.	Test Items	Requirements		Procedures	
Mechanical Requirements					
3.8.6	Tensile Strength of wire Termination	Wire Size	Tensile Strength of Wire Termination(min.)		Apply a pull-off load to terminated wire of contact secured on the tester, Operation Speed : 50 mm/min. The load is applied in (1) the axial and (2) the traverse directions as specified. Fig.5
			Axial Direction	Traverse Direction	
		(AWG)	N(kgf)	N(kgf)	
		26	19.6(2.0)	11.8(1.2)	
28	14.7(1.5)				
3.8.7	Post Retention Force	9.8 N(1.0 kgf) Min.		Measure post retention force. Operation Speed : 50 mm/min. Fig.6	
3.8.8	Contact Retention Force	4.9 N(0.5 kgf) Min.		Apply an axial pull-off load to crimped wire. Operation Speed : 50 mm/min.	
3.8.9	Panel Mounting Force (To be applied to post header relay panel mount type)	49 N(5 kgf) MAX.		Measure panel retention force using panel of nominal cut-out dimensions as specified in the drawing. Loading is made from the punch entering direction of the cut-out hole. See Fig.7	
3.8.10	Panel Retention Force (To be applied to post header relay panel mount type)	83.3 N(8.5 kgf) Min.		Measure panel retention force using panel of nominal cut-out dimensions as specified in the drawing. Loading is made from the punch entering direction of the cut-out hole. See Fig.8	
3.8.11	Connector Mating /Unmating Force	See Fig.12		Operation Speed : 50 mm/min. Measure the force required to mate and unmate connectors.	
3.8.12	Durability (Repeated Mate / Unmating)	20 mΩ Max. (Final)		Operation Speed : 50 mm/min. No. of Cycles : 30 cycles.	

Fig. 2 (To be continued)

tyco Electronics	Tyco Electronics AMP Shanghai Ltd.	PAGE 5 of 17	Document No. 108-5525	REV A	LOC ES
----------------------------	---	------------------------	---------------------------------	-----------------	------------------

Para.	Test Items	Requirements	Procedures
3.8.13	Vibration (Low Frequency)	No electrical discontinuity greater than 1 μ sec. Shall occur. 20 m Ω Max. (Final)	Subject mated connectors to 10-55-10 Hz traversed in 1 minute at 1.52 mm amplitude 2 hours each of 3 mutually perpendicular planes. 10 mA applied. MIL-STD-202 TEST METHOD 201 CONDITION A IEC 68-2-6 Mounting : Fig. 9
3.8.14	Physical Shock	No electrical discontinuity greater than 1 μ sec. Shall occur. 20 m Ω Max.(Final)	Accelerated Velocity : 490 m/s ² (50 G) Waveform: halfsine shock pulse Duration: 11 msec. Number of Drops : 3 drops each to normal and reversed directions of X, Y and Z axes, totally 18 drops. 10 mA DC applied. MIL-STD-202 TEST METHOD 213 CONDITION A IEC 68-2-27 Mounting : Fig. 9
3.8.15	Hammerring Shocks	No electrical discontinuity greater than 1 μ sec.shall occur. 20 m Ω Max.(Final)	Under 10000 cycles of repeated hammering shocks of the condition as shown Fig.10,with the test current of 1mA at 10VDC applied to the circuit as shown in Fig.11. During the test, the circuit shall be monitored for fluctuation of electrical resistance.
3.8.16	Solderability	Wet Solder Coverage : 90 % Min.	Solder Temperature : 230 \pm 5 $^{\circ}$ C Immersion Duration :3 \pm 0.5 seconds Flux : Alpha 100 (NON-active rosin base)

Fig. 2 (To be continued)

	Tyco Electronics AMP Shanghai Ltd.	PAGE 6 of 17	Document No. 108-5525	REV A	LOC ES
---	---	------------------------	---------------------------------	-----------------	------------------

Para	Test Items	Requirements	Procedures
3.8.17	Resistance to Soldering Heat	No physical damage shall occur.	<u>Flow Soldering</u> Test connector on PCB. Solder Temperature : 260 ± 5 °C Immersion Duration : 10 ± 1 sec. <u>Reflow Soldering</u> Reflow Soldering by next conditions. Preheat:100 ~150 60sec. Min. Heating:210 Min. 30sec. Max. Peak Temperature:240 Max. (Measured at housing surface) <u>Manual Soldering</u> Temperature:350 ± 10 for 3+1□-0 Seconds. To be no damage by the top of iron. at soldering tynes.
Environmental Requirements			
3.8.18	Thermal Shock	20 mΩ Max. (Final)	Mated connector -55 °C / 30 min., +85 °C / 30 min. Making this a cycle, repeat 500cycles. IEC 68-2-14
3.8.19	Humidity, Steady State	Insulation resistance 100 MΩ Min.(Final) Termination resistance 20 mΩ Max. (Final)	Mated connector, 90 ~95 %R.H. 40 °C, 500 hours IEC 68-2-3
3.8.20	Humidity-Temperature Cycling	Insulation resistance 100 MΩ Min.(final) Termination resistance 20 mΩ Max. (Final)	Mated connector, 25 ~65 °C, 90 ~95 % R.H. 10 cycles Cold shock -10 °C performed IEC 68-2-38
3.8.21	Salt Spray	20 mΩ Max. (Final)	Subject mated 35 ± 2 connectors to 5 ± 1 % salt concentration for 48 hours : Aften test, nirse the samples with waten and recondition the room temperature for hour. IEC 68-2-11

Fig. 2 (To be continued)

tyco Electronics	Tyco Electronics AMP Shanghai Ltd.	PAGE 7 of 17	Document No. 108-5525	REV A	LOC ES
----------------------------	---	------------------------	---------------------------------	-----------------	------------------

Para.	Test Items	Requirements	Procedures
3.8.22	Temperature Life (Heat Aging)	20 mΩ Max. (Final)	Mated connector 85 ± 2°C, 500 hours IEC 68-2-2
3.8.23	Resistance to Cold	20 mΩ Max. (Final)	Mated connector -40 ± 3 °C, 500 hours IEC 68-2-1
3.8.24	Industrial Gas (SO2)	20 mΩ Max. (Final)	Mated connector SO2 Gas : 10 ± 3 ppm, 95 % R.H. 35 ± 2 °C, 240 hours
3.8.25	Industrial Gas (H2S)	20 mΩ Max. (Final)	Mated connector H2S Gas : 3 ppm, 40 ± 3 75 % R.H., 240 hours
3.8.26	Industrial Gas (Ammonia)	20 mΩ Max. (Final)	After 72 hours exposure in ammonia chamber with 25 cc of 3 % ammonia solution for every liter of chamber capacity.
3.8.27	Resistance to Solvent	Connector shall be free from fusion and discoloration that determental to connector function.	Unmated connector (Isopropylalcohol) Immerse in solvent nominal temperature 90 seconds.

Fig. 2 (End)

	Tyco Electronics AMP Shanghai Ltd.	PAGE 8 of 17	Document No. 108-5525	REV A	LOC ES
---	---	-------------------------	----------------------------------	------------------	-------------------

4. Product Qualification Test Sequence

Test Examination	Test Group															
	1	2	3	4	5	6	7	8	9	10	11	12	13	14	15	16
	Test Sequence (a)															
Examination of Product	1,6	1,3	1,3	1,3	1,3	1,3	1,3	1,3	1,5	1,5	1,5	1,5	1,5	1,5	1,5	1,5
Termination Resistance (Low Level)									2,4	2,4	2,4	2,4	2,4	2,4	2,4	2,4
Dielectric withstanding Voltage	2,5															
Insulation Resistance	3															
Temperature Rising		2														
Tensile Strength of Wire Termination			2													
Post Retention Force				2												
Contact Retention Force					2											
Panel Mounting Force						2										
Panel Retention Force							2									
Connector Mating/Unmating Force								2								
Durability (Repeated Mate/Unmating)									3							
Vibration (Low Frequency)										3						
Physical Shock											3					
Hammering Shocks												3				
Solderability													3			
Resistance to Soldering Heat														3		
Thermal Shock															3	
Humidity (Steady State)	4															3
Humidity-Temperature Cycling																
Salt Spray																
Temperature Life (Heat Aging)																
Resistance to Cold																
Industrial SO ₂ Gas																
Industrial H ₂ S Gas																
Industrial Ammonia Gas																
Resistance to Solvent																

(a) Numbers indicate sequence in which the tests are performed.

Fig.3 (To be continued)

	Tyco Electronics AMP Shanghai Ltd.	PAGE 9 of 17	Document No. 108-5525	REV A	LOC ES
---	---	------------------------	---------------------------------	-----------------	------------------

Test Examination	Test Group															
	17	18	19	20	21	22	23	24								
	Test Sequence (a)															
Examination of Product	1,5	1,5	1,5	1,5	1,5	1,5	1,5	1,5								
Termination Resistance (Low Level)	2,4	2,4	2,4	2,4	2,4	2,4	2,4	2,4								
Dielectric withstanding Voltage																
Insulation Resistance																
Temperature Rising																
Crimp Tensile Strength																
Post Retention Force																
Contact Retention Force																
Panel Mounting Force																
Panel Retention Force																
Connector Mating/Unmating Force																
Durability (Repeated Mate/Unmating)																
Vibration (Low Frequency)																
Physical Shock																
Hammering Shocks																
Solderability																
Resistance to Soldering Heat																
Thermal Shock																
Humidity (Steady State)																
Humidity-Temperature Cycling	3															
Salt Spray		3														
Temperature Life (Heat Aging)			3													
Resistance to Cold				3												
Industrial SO ₂ Gas					3											
Industrial H ₂ S Gas						3										
Industrial Ammonia Gas							3									
Resistance to Solvent								3								

(a) Numbers indicate sequence in which the tests are performed.

Fig.3 (End)

	Tyco Electronics AMP Shanghai Ltd.	PAGE 10 of 17	Document No. 108-5525	REV A	LOC ES
---	---	-------------------------	---------------------------------	-----------------	------------------

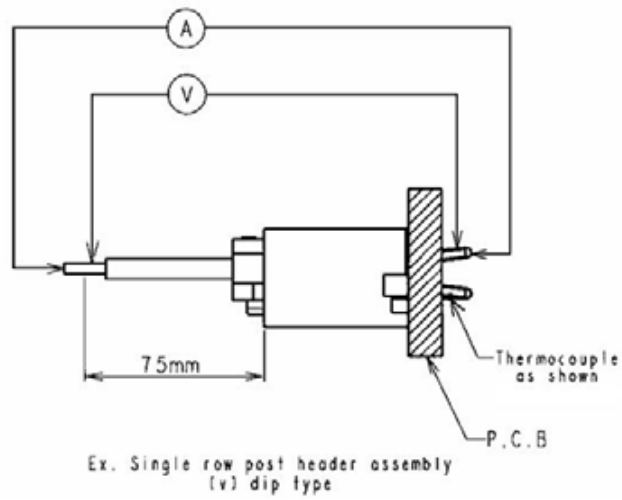

Fig. 4

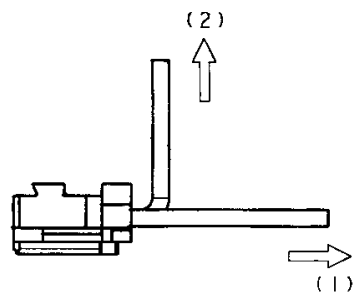

Fig. 5

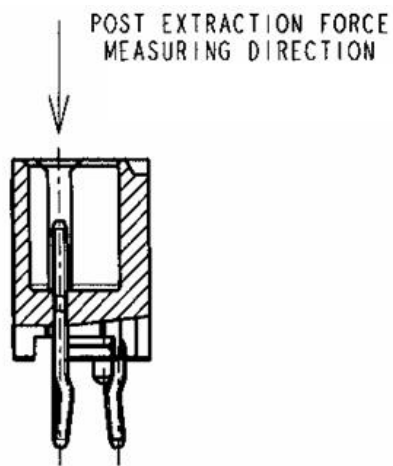

Fig. 6

	<p>Tyco Electronics AMP Shanghai Ltd.</p>	<p>PAGE 11 of 17</p>	<p>Document No. 108-5525</p>	<p>REV A</p>	<p>LOC ES</p>
--	---	--------------------------	----------------------------------	------------------	-------------------

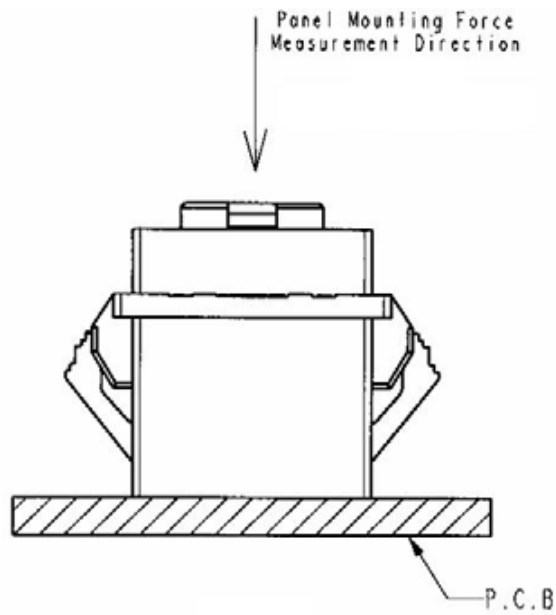

Fig. 7

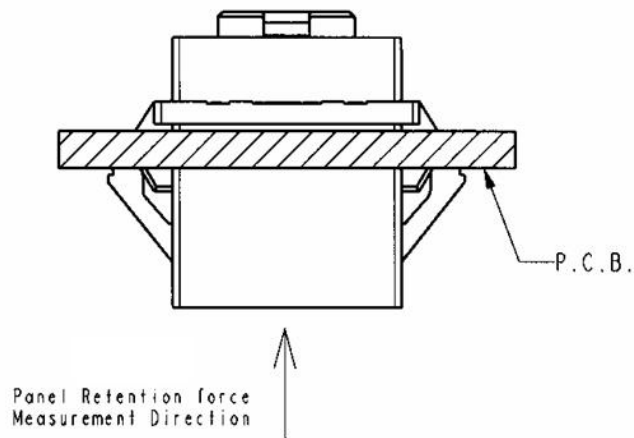



Fig. 8

	<p>Tyco Electronics AMP Shanghai Ltd.</p>	<p>PAGE 12 of 17</p>	<p>Document No. 108-5525</p>	<p>REV A</p>	<p>LOC ES</p>
---	--	--------------------------	----------------------------------	------------------	-------------------

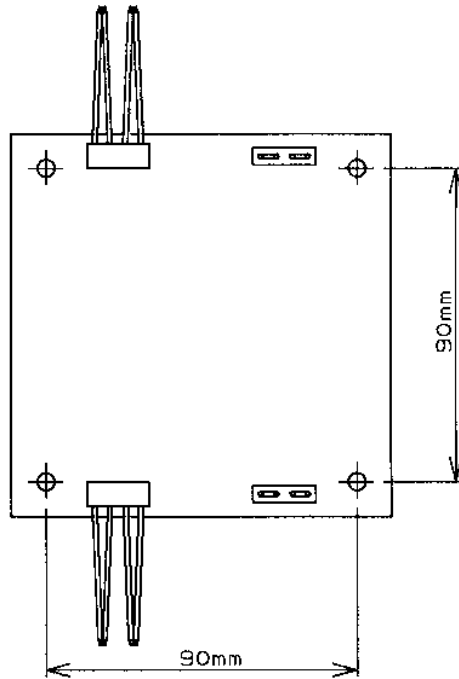
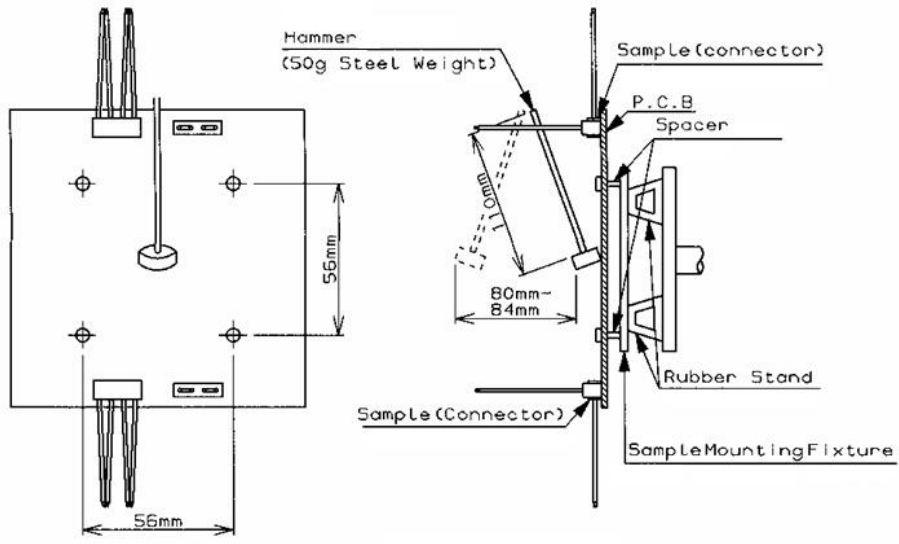

Fig. 9



Hammer Weight Striking Frequency: 1 Strike/Second

Fig. 10

	<p>Tyco Electronics AMP Shanghai Ltd.</p>	<p>PAGE 13 of 17</p>	<p>Document No. 108-5525</p>	<p>REV A</p>	<p>LOC ES</p>
--	--	--------------------------	----------------------------------	------------------	-------------------

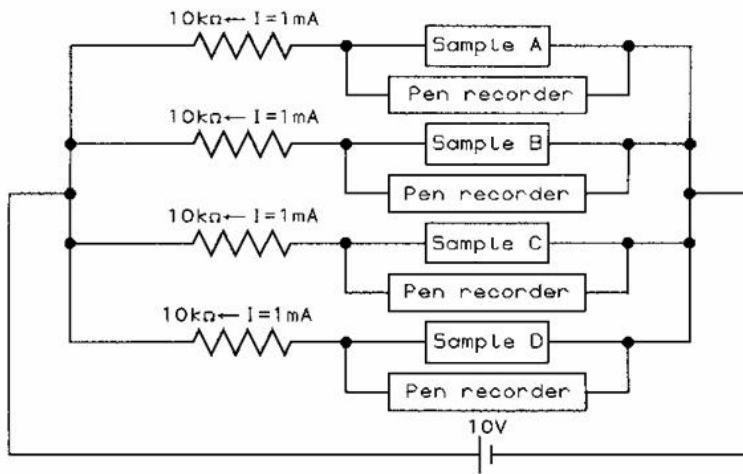



Fig. 11

	<p>Tyco Electronics AMP Shanghai Ltd.</p>	<p>PAGE 14 of 17</p>	<p>Document No. 108-5525</p>	<p>REV A</p>	<p>LOC ES</p>
---	--	--------------------------	----------------------------------	------------------	-------------------

Initial and 30 cycles

No. of Pos	Connector Mating /Unmating Force *Note		Connector Mating /Unmating Force (To be applied post header relay panel mount Type by measurement on lock side)	
	Mating Force N(kgf) max.	Unmating Force N (kgf) min.	Mating Force N (kgf) max.	Unmating Force N (kgf) min.
2	29.302 (2.99)	4.508 (0.46)	31.752 (3.24)	5.978 (0.61)
3	31.948 (3.26)	5.194 (0.53)	34.398 (3.51)	6.664 (0.68)
4	34.594 (3.53)	5.880 (0.60)	37.044 (3.78)	7.350 (0.75)
5	37.240 (3.80)	6.566 (0.67)	42.140 (4.30)	9.016 (0.92)
6	39.886 (4.07)	7.252 (0.74)	44.786 (4.57)	9.702 (0.99)
7	42.532 (4.34)	7.938 (0.81)	47.432 (4.84)	10.388 (1.06)
8	45.178 (4.61)	8.624 (0.88)	50.078 (5.11)	11.074 (1.13)
9	47.824 (4.88)	9.310 (0.95)	57.624 (5.88)	14.210 (1.45)
10	50.470 (5.15)	9.996 (1.02)	60.270 (6.15)	14.896 (1.52)
11	53.116 (5.42)	10.682 (1.09)	62.916 (6.42)	15.582 (1.59)
12	55.762 (5.69)	11.368 (1.16)	65.562 (6.69)	16.268 (1.66)
13	58.408 (5.96)	12.054 (1.23)	68.208 (6.96)	16.954 (1.73)
14	60.956 (6.22)	12.740 (1.30)	75.656 (7.72)	20.090 (2.05)
15	63.602 (6.49)	13.426 (1.37)	78.302 (7.99)	20.776 (2.12)
16	66.248 (6.76)	14.112 (1.44)	80.948 (8.26)	21.462 (2.19)
17	68.894 (7.03)	14.798 (1.51)	83.594 (8.53)	22.148 (2.26)
18	71.540 (7.30)	15.484 (1.58)	86.240 (8.80)	22.834 (2.33)
19	74.186 (7.57)	16.170 (1.65)	88.886 (9.07)	23.520 (2.40)
20	76.832 (7.84)	16.856 (1.72)	91.532 (9.34)	24.206 (2.47)
22	82.124 (8.38)	18.228 (1.86)	91.924 (9.38)	23.128 (2.36)
24	87.416 (8.92)	19.600 (2.00)	97.216 (9.92)	24.500 (2.50)
26	92.708 (9.46)	20.972 (2.14)	102.508 (10.46)	25.872 (2.64)
28	98.000 (10.00)	22.344 (2.28)	107.800 (11.00)	27.244 (2.78)
30	103.292 (10.54)	23.716 (2.42)	117.992 (12.04)	31.066 (3.17)
32	108.584 (11.08)	25.088 (2.56)	123.284 (12.58)	32.438 (3.31)
34	113.876 (11.62)	26.460 (2.70)	128.576 (13.12)	33.810 (3.45)
36	119.168 (12.16)	27.832 (2.84)	133.868 (13.66)	35.182 (3.59)
38	124.460 (12.70)	29.204 (2.98)	139.160 (14.20)	36.554 (3.73)
40	129.752 (13.24)	30.576 (3.12)	144.452 (14.74)	37.926 (3.87)

Note : To be applied same specification to post header relay panel mount type by measurement on opposite lock side.

Fig. 12

	Tyco Electronics AMP Shanghai Ltd.	PAGE 15 of 17	Document No. 108-5525	REV A	LOC ES
---	---	-------------------------	---------------------------------	-----------------	------------------

The applicable product descriptions and part numbers are as shown in Fig.1.

Product Part No.	Description
×-353293-×	Receptacle Assembly(MT Type) 2 ~20 Pos.
×-353297-× ×-84742-×	Single Row Post Header Assembly (V) DIP Staggered Type With Boss With Kink 2 ~20 Pos.
×-353300-×	Single Row Post Header Assembly(V) DIP Staggered Type Without Boss Without Kink 2 ~20 Pos.
×-353301-×	Tube Packing for Single Row Post Header Assembly (V) DIP Staggered Type Without Boss Without Kink 2 ~20 Pos.
×-353520-×	Single Row Post Header Assembly (V) SMT Type With Boss 3 ~20 Pos.
×-353521-×	Emboss Tape Pakaged for Single Row Post Header Assembly (V) SMT Type With Boss 3 ~20 Pos.
×-353523-×	Single Row Post Header Assembly (V) SMT Type Without Boss 3 ~20 Pos.
×-353524-×	Emboss Tape Packaged for Single Row Post Header Assembly (V) SMT Type Without Boss 3 ~20 Pos.
×-353303-× ×-84743-×	Single Row Post Header Assembly (H) DIP Staggered Type With Kink 2 ~20 Pos

Fig. 1(To be continued)

	Tyco Electronics AMP Shanghai Ltd.	PAGE 16 of 17	Document No. 108-5525	REV A	LOC ES
---	---	-------------------------	---------------------------------	-----------------	------------------

Product Part No.	Description
×-353320-×	Single Row Post Header Assembly Panel Mount Type 2 ~20 Pos.
×-353294-×	Double Row Holdr Housing 22 ~40 Pos.(Only Ever Number Pos.)
×-353526-×	Single Row Post Header Assembly (H) SMT Type With Boss 2 ~20 Pos.
×-353527-×	Emboss Tape Packaged for Single Row Post Header Assembly (H) SMT Type With Boss 2 ~20 Pos.
×-353529-×	Single Row Post Header Assembly (H) SMT Type Without Boss 2 ~20 Pos.
×-353530-×	Emboss Tape Packaged for Single Row Post Header Assembly (H) SMT Type Without Boss 2 ~20 Pos.
×-353308-×	Duble Row Post Header Assembly (V) DIP Staggered Type With Boss With Kink 22 ~40 Pos.(Only Even Number Pos.)
×-353314-×	Double Row Post Header Assembly (V) SMT Type With Boss 22 ~40 Pos.(Only Even Number Pos.)
×-353322-×	Double Row Post Header Assembly Panel Mount Type 22 ~40 Pos.
×-84761-×	Double Row Post Header Assembly (H) DIP Type 22 ~40 Pos.(Only Even Number Pos.)

Fig. 1(End)

	Tyco Electronics AMP Shanghai Ltd.	PAGE 17 of 17	Document No. 108-5525	REV A	LOC ES
---	---	-------------------------	---------------------------------	-----------------	------------------