

THIS DRAWING IS UNPUBLISHED  
 ALL RIGHTS RESERVED

REV	DATE	DESCRIPTION	BY	CHK	APP
00					
01		REVISED PER EDD-11-611461			

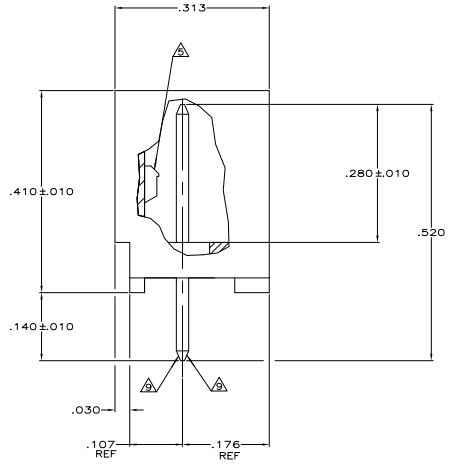

- △ MATERIAL: HEADER - POLYESTER UL94V-0 (BLACK)  
POST - COPPER ALLOY.
- △ SOLDER SIDE OF P.C. BOARD SHOWN.
- 3. PARTS COMPLY WITH AMP SOLDERABILITY SPEC 109-11-2.
- △ ONE HOLE MAY BE UNDERSIZED (.032-.035 DIA) FOR ASSEMBLY RETENTION DURING WAVE SOLDERING.
- △ LATCH DETENT FEATURE OCCURS 2 PLACES ON EACH END (MAXIMUM OF FOUR PER PART). FOR 2 THRU 5 CIRCUIT HEADERS, LATCH FEATURE OCCURS BETWEEN EACH CIRCUIT.
- △ COORDINATE DIMENSION APPLIES FROM CENTER OF ACTUAL FEATURE.
- △ POST: 93/7 BRIGHT TIN-LEAD PLATING (-2 THRU -14) OR 100% BRIGHT TIN PLATING (-32 THRU -44).
- △ POST MUST WITHSTAND 3.0 LBS (13.34 NEWTONS) MIN FORCE WITHOUT DISLODGING, EITHER DIRECTION.
- △ TWO SIDES OF TAPER, AS SHOWN, MUST BE PLATED. TYPICAL, BOTH ENDS.
- △ TWO SIDES OF TAPER, AS SHOWN, AND TIP MAY BE UNPLATED. TYPICAL, BOTH ENDS.
- △ SLOTS MAY OR MAY NOT APPEAR ON THESE PARTS.
- 12. UL RECOGNIZED (UR) LOGO AND CSA LOGO WILL APPEAR ON THE SIDE OF THE PART. THE AMP LOGO MAY APPEAR ON THE SIDE OR ON BOTTOM OF PART.

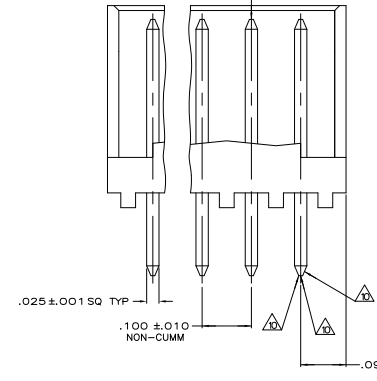
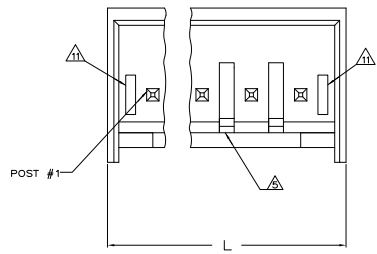
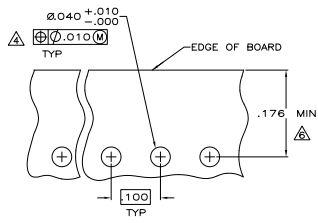

RECOMMENDED MOUNTING HOLE PATTERN FOR .063 THK PRINTED CIRCUIT BOARD

1.484	37.69	14	4-644892-4
1.384	35.15	13	4-644892-3
1.284	32.61	12	4-644892-2
1.184	30.07	11	4-644892-1
1.084	27.53	10	4-644892-0
.984	24.99	9	3-644892-9
.884	22.45	8	3-644892-8
.784	19.91	7	3-644892-7
.684	17.37	6	3-644892-6
.584	14.83	5	3-644892-5
.484	12.29	4	3-644892-4
.384	9.75	3	3-644892-3
.284	7.21	2	3-644892-2

1.484	37.69	14	1-644892-4
1.384	35.15	13	1-644892-3
1.284	32.61	12	1-644892-2
1.184	30.07	11	1-644892-1
1.084	27.53	10	1-644892-0
.984	24.99	9	644892-9
.884	22.45	8	644892-8
.784	19.91	7	644892-7
.684	17.37	6	644892-6
.584	14.83	5	644892-5
.484	12.29	4	644892-4
.384	9.75	3	644892-3
.284	7.21	2	644892-2

	.025	.064	.100	2.54	.520	13.21
.010	0.25	.092	2.34	.410	10.41	
.005	0.13	.063	1.60	.313	7.95	
.001	0.03	.040	1.02	.280	7.11	
.0003500	.00889	.035	0.89	.176	4.47	
.0001500	.00381	.032	0.81	.140	3.56	
.000	0.00	.030	0.76	.107	2.72	
IN	MM	IN	MM	IN	MM	

CONVERSION TABLE



THIS DRAWING IS A CONTROLLED DOCUMENT.

TE Connectivity

CST-100 SHRIMDED HEADER ASSEMBLY, FRICTION LOCK, STRAIGHT POST, TIN OR TIN LEAD PLATED

REVISED PER EDD-11-611461

DATE: 10-11-2011

BY: 10-11-2011

CHK: 10-11-2011

APP: 10-11-2011

REVISED PER EDD-11-611461

DATE: 10-11-2011

BY: 10-11-2011

CHK: 10-11-2011

APP: 10-11-2011