

**FEATURES**

- Green-mode PWM to support “Blue Angel” Norm
- Low start up current 30uA
- Low operation current 3mA
- Leading-edge blanking
- Built-in synchronized slope compensation
- Constant output power limit for universal AC input
- Current mode operation
- Cycle-by-cycle current limiting
- Under voltage lockout (UVLO)
- Programmable PWM frequency
- GATE output maximum voltage clamped at 18V
- Totem pole output includes soft driving for better EMI
- Build-in limited-power-control to meet safety requirement
- Programmable over-temperature protection
- Few external components & low cost solution

**DESCRIPTION**

This highly integrated PWM controllers, SG6841 series, provides several features to enhance the performance of low power flyback converters. To minimize standby power consumption, the proprietary green-mode function provides off-time modulation to linearly decrease the switching frequency under light-load conditions. This green-mode function assists the power supply to easily meet the power conservation requirement. Due to BiCMOS process, the start-up current and operation current is reduced to 30uA and 3mA, respectively, to improve power conversion efficiency. Large start-up resistance can be used for further power saving. Built-in synchronized slope compensation ensures the stability of peak current mode control. A proprietary internal compensation ensures constant output power limit for universal AC input voltage from 90VAC to 264VAC.

**APPLICATIONS**

General-purpose switching mode power supplies and flyback power converters, and

- Power Adapter
- Open-frame SMPS
- Battery Charger Adapter

SG6841 provides many protection functions. Pulse by pulse current limit ensures a constant output current under short circuit. If a short circuit failure or over load happens, the SG6841 will shut off after a continuous high voltage detection on FB pin. The gate output is clamped at 18V to protect the power MOS from over voltage damage. An external NTC thermistor can be applied to sense the ambient temperature for over-temperature protection. The SG6841 series are available in 8-pin DIP and SO packages.

**TYPICAL APPLICATION**

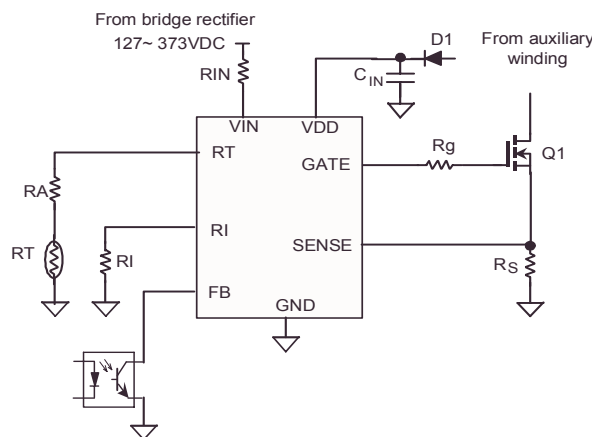

## MARKING DIAGRAMS

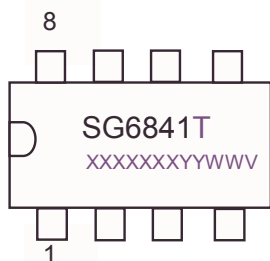

T: D = DIP, S = SOP  
 XXXXXXXX: Wafer Lot  
 YY: Year; WW: Week  
 V: Assembly Location

## PIN CONFIGURATION

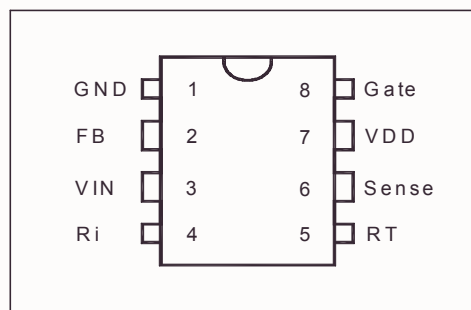

## ORDERING INFORMATION

Part Number	Package
SG6841S	8-Pin SOP
SG6841D	8-Pin DIP

## PIN DESCRIPTIONS

Pin No.	Symbol	Function	Description
1	GND	Ground	Ground.
2	FB	Feedback	The signal from external compensation circuit is feed into this pin. The PWM duty cycle is determined by this FB pin and current sense signal from Pin 6.
3	VIN	Start-Up	This pin is pulled high to the rectified line input through a resistor for start-up. Since the start-up current requirement for SG6841 is very small, a large start-up resistance can be used to minimize power loss. Under normal operation, this pin is also used to detect line voltage to compensate for constant output power limit for universal AC input.
4	R <sub>i</sub>	Reference Setting	A resistor from R <sub>i</sub> pin to ground will generate a constant current source for SG6841. This current is used to charge an internal capacitor and hence the switching frequency are determined. Increasing the resistance will decrease the current source and reduce the switching frequency. A 26kΩ resistor R <sub>i</sub> creates a 50uA constant current I <sub>i</sub> and generates 65kHz switching frequency.
5	RT	Temperature Protection	For over-temperature protection. An external NTC thermistor is connected from this pin to ground. The impedance of the NTC will decrease under high temperature. Once the voltage on RT pin drops below a fixed limit, the PWM output will be disabled.
6	SENSE	Current Sense	Current sense. The sensed voltage is used for current mode control and pulse-by-pulse current limiting. If a short circuit failure happens on current sense resistor, the SG6841 will shut off after a continuous low voltage detection on SENSE pin.
7	VDD	Power supply	Power Supply.
8	GATE	Driver Output	The totem-pole output driver for the power MOSFET. A soft driving waveform is implemented to improve EMI.

**BLOCK DIAGRAM**

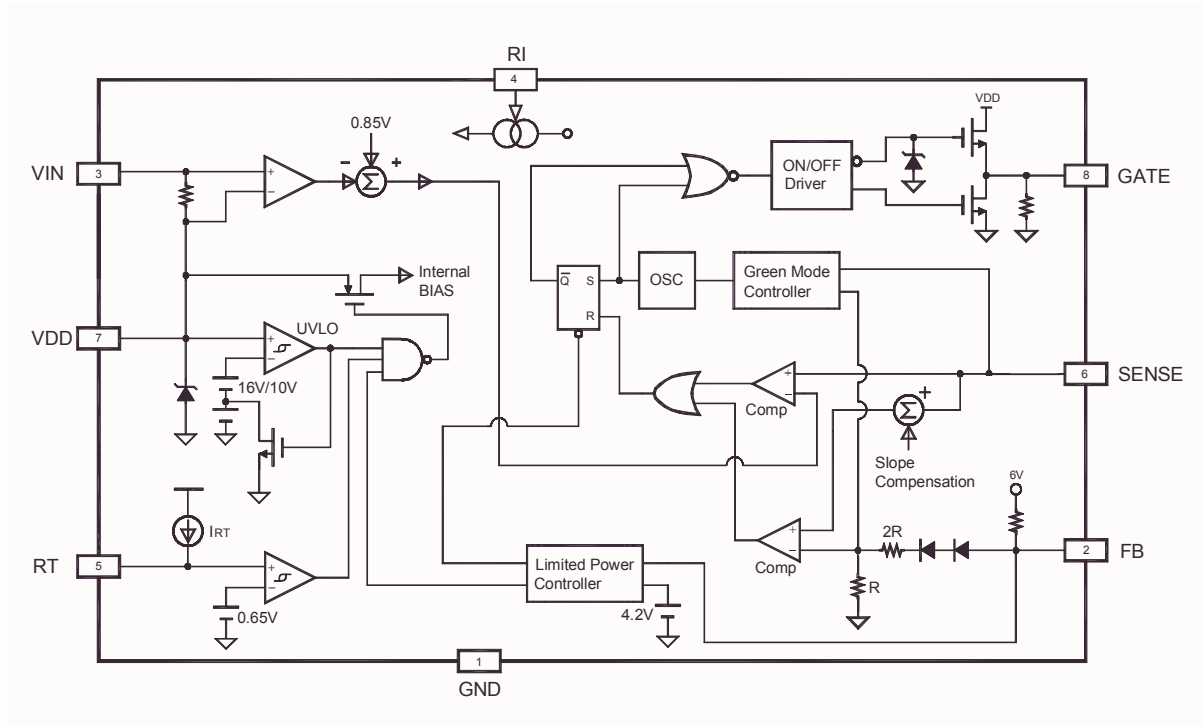

**ABSOLUTE MAXIMUM RATINGS**

Symbol	Parameter	Value	Unit
V <sub>DD</sub>	DC Supply Voltage	30	V
	Zener clamp	32	V
	Zener current	10	mA
I <sub>OUT</sub>	Gate Output Current	500	mA
V <sub>FB</sub>	Input Voltage to FB Pin	-0.3 to 7V	V
V <sub>Sense</sub>	Input Voltage to SENSE Pin	-0.3 to 7V	V
V <sub>RT</sub>	Input Voltage to RT Pin	-0.3 to 7V	V
V <sub>Ri</sub>	Input Voltage to Ri Pin	-0.3 to 7V	V
P <sub>D</sub>	Power Dissipation	1	W
R $\theta$ j-a	Thermal Resistance Junction-air		
	DIP	82.5	$^{\circ}\text{C}/\text{W}$
	SOP	141	
T <sub>J</sub>	Operating Junction Temperature	150	$^{\circ}\text{C}$
T <sub>A</sub>	Operating Ambient Temperature	-30 to 85	$^{\circ}\text{C}$
T <sub>stg</sub>	Storage Temperature Range	-55 to +150	$^{\circ}\text{C}$
	ESD Capability, HBM model	3.0	kV
	ESD Capability, Machine model	250	V

**RECOMMENDED OPERATING CONDITIONS**

Symbol	Parameter	Value	Unit
V <sub>DD</sub>	DC Supply Voltage	<20	V
T <sub>A</sub>	Operating Ambient Temperature	-20 to +85	$^{\circ}\text{C}$
R <sub>i</sub>	Current source Setting	26	kohms

**ELECTRICAL CHARACTERISTICS**
**Feedback Input Section**

Symbol	Parameter	Test Condition	Min.	Typ.	Max.	Unit
A <sub>V</sub>	Input-voltage to current-sense attenuation		1/3.25	1/3	1/2.75	V/V
Z <sub>FB</sub>	Input impedance		2	4.5	8	k $\Omega$
I <sub>FB</sub>	Bias current				2	mA
V <sub>OZ</sub>	Input voltage for zero duty cycle				1.2	V

**High-integrated Green-mode PWM Controller**
**SG6841**
**Current Sense Section**

Symbol	Parameter	Test Condition	Min.	Typ.	Max.	Unit
Z <sub>CS</sub>	Input impedance		8	12	16	KΩ
T <sub>PD</sub>	Delay to Output			150	200	nsec
V <sub>TH</sub>	Threshold voltage for current limit	I <sub>VIN</sub> = 0 uA	0.8	0.85	0.9	V
ΔV <sub>TH</sub> @ I <sub>VIN</sub>	The change of threshold voltage versus the input current of the Vin	I <sub>VIN</sub> = 220 uA	-0.09	-0.15	-0.21	V
V <sub>SENSE0</sub>	Threshold voltage for I <sub>VIN</sub> = 80uA	I <sub>VIN</sub> = 80 uA	0.73	0.81	0.89	V
t <sub>delay-lps</sub>	The delay time of limited-power-control	R <sub>I</sub> =26KOhms		31		msec

**Oscillator Section**

Symbol	Parameter	Test Condition	Min.	Typ.	Max.	Unit
F <sub>OSC</sub>	Frequency in nominal mode	R <sub>I</sub> =26KOhms	60	65	70	KHz
F <sub>osc-green</sub>	Frequency in green mode	R <sub>I</sub> =26KOhms		10	16	KHz
V <sub>G</sub>	End of green mode voltage at FB pin			1.9		V
V <sub>N</sub>	Beginning of frequency reducing at FB pin			2.6		V
S <sub>G</sub>	Slope for green mode modulation	R <sub>I</sub> =26KOhms	50	80	120	Hz/mV
F <sub>DV</sub>	Frequency variation versus V <sub>DD</sub> deviation	V <sub>DD</sub> =10 to 20V			5	%
F <sub>DT</sub>	Frequency variation versus Temp. deviation	T <sub>A</sub> =-30 to 85 °C			5	%

**PWM Section**

Symbol	Parameter	Test Condition	Min.	Typ.	Max.	Unit
DC <sub>(MAX)</sub>	Maximum Duty Cycle		75	80	90	%
DC <sub>(MIN)</sub>	Minimum Duty Cycle		-	-	0	%
Bnk	Leading edge blanking time		200	270	350	nsec

**Output Section**

Symbol	Parameter	Test Condition	Min.	Typ.	Max.	Unit
V <sub>OL</sub>	Output Voltage Low	V <sub>DD</sub> = 12V, I <sub>o</sub> = 150mA			1.5	V
V <sub>OH</sub>	Output Voltage High	V <sub>DD</sub> = 12V, I <sub>o</sub> = 50mA	8V			V
t <sub>r</sub>	Rising Time	V <sub>DD</sub> = 13V, CL=1nF	150	250	350	nsec
t <sub>f</sub>	Falling Time	V <sub>DD</sub> = 13V, CL=1nF	30	50	90	nsec

**Under-voltage Lockout Section**

Symbol	Parameter	Test Condition	Min.	Typ.	Max.	Unit
V <sub>TH(ON)</sub>	Start Threshold Voltage		15	16	17	V
V <sub>DD(min)</sub>	Min. Operating Voltage		9	10	11	V

### Over-Temperature Protection Section

Symbol	Parameter	Test Condition	Min.	Typ.	Max.	Unit
I <sub>RT</sub>	Output current of pin RT	R <sub>i</sub> =26KOhms	92	100	108	uA
V <sub>OTP,STOP</sub>	Threshold voltage for over-temperature protection. Turn-off point. Duty cycle is reduced to 0%.		0.585	0.62	0.655	V
V <sub>OTP,START</sub>	Threshold voltage for over-temperature protection. Starting point. Duty cycle starts to decrease.			0.65		V

### Total Standby Current Section

Symbol	Parameter	Test Condition	Min.	Typ.	Max.	Unit
I <sub>DD ST</sub>	Start-up Current	VDD=14.5V		30	40	uA
I <sub>DD OP</sub>	Operating Supply Current	FB=SENSE=0V GATE=1000pF VDD=15.5V	-	3	5	mA

**TYPICAL CHARACTERISTICS**

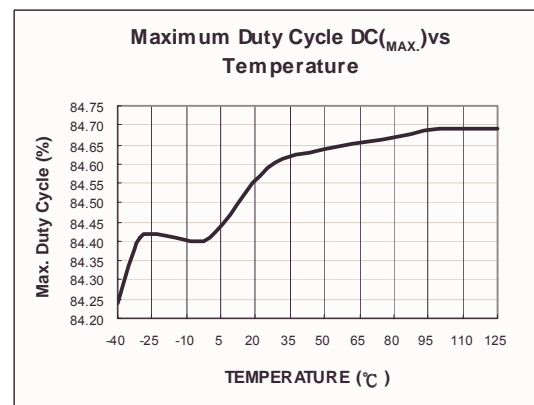
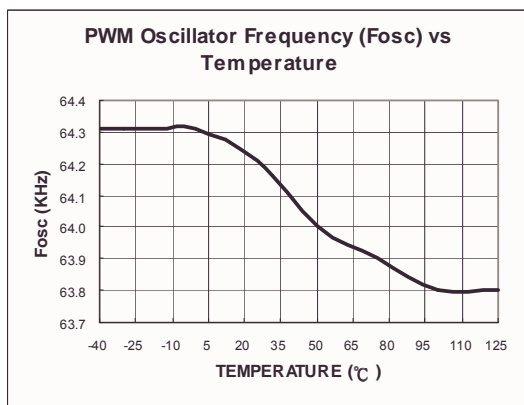
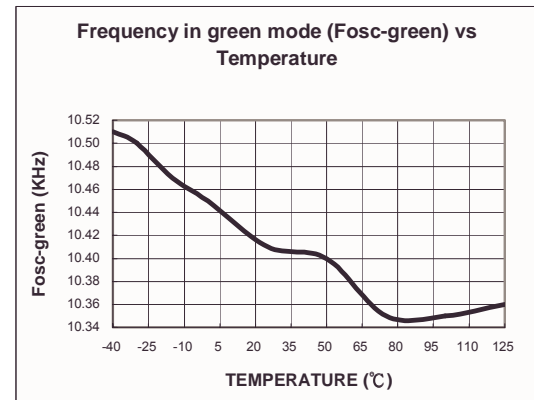
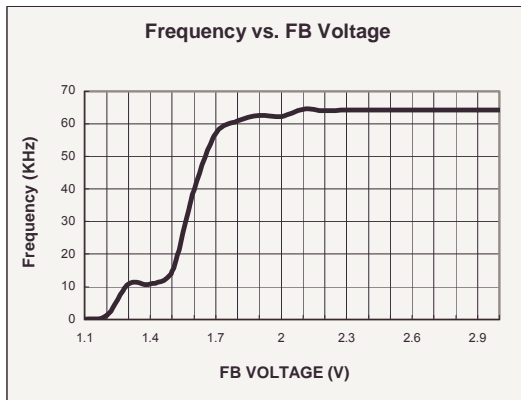
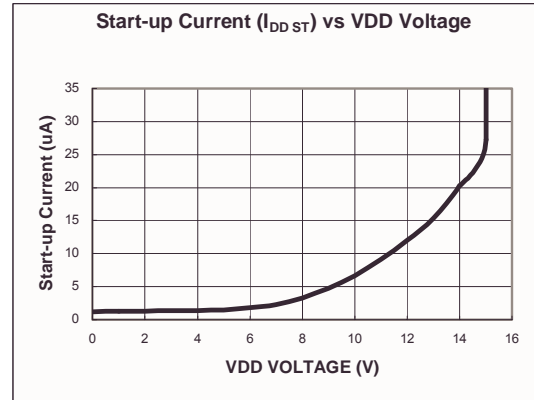
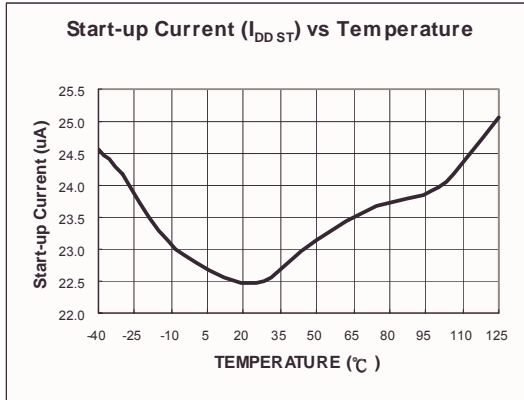

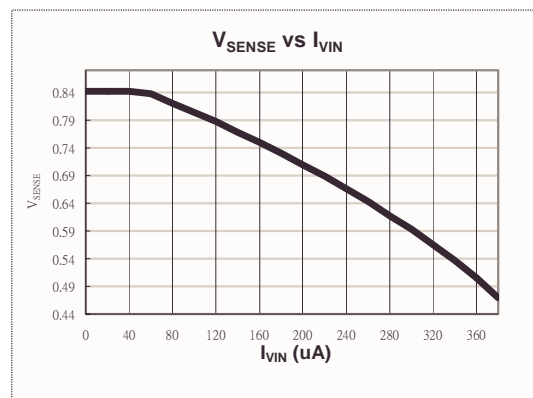
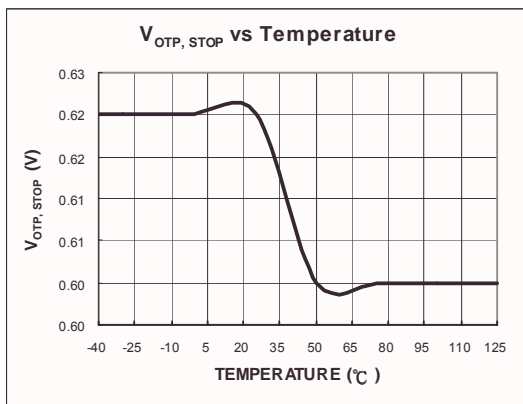
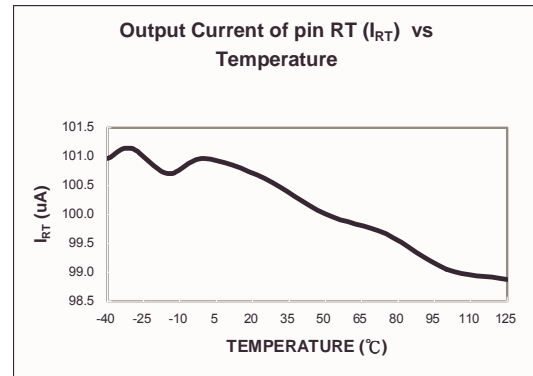
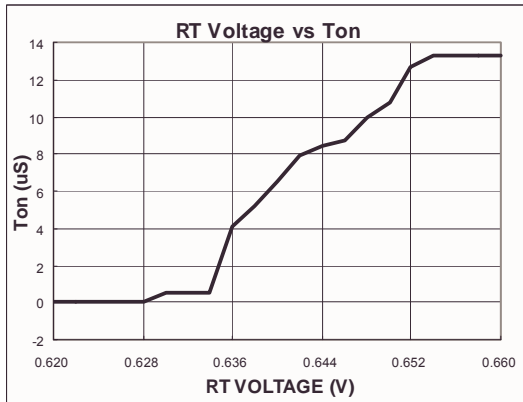
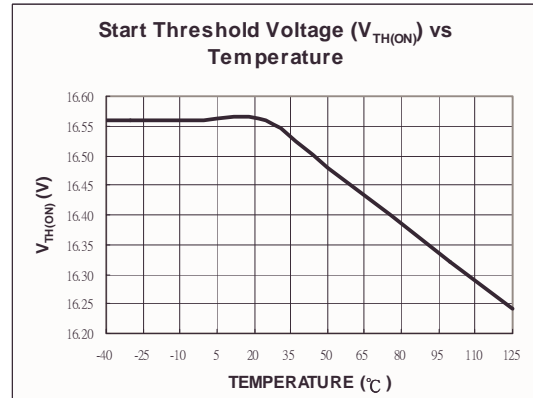
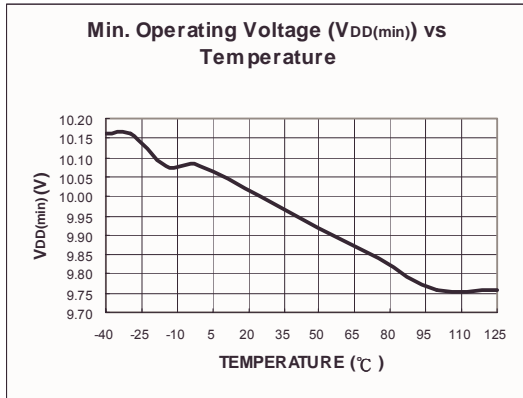



## OPERATION DESCRIPTION

### Start-up current

Typical start-up current is only 30uA so that a high resistance, and low-wattage, start-up resistor can be used to minimize power loss. For an AC/DC adapter with universal input range, a 1.5 MΩ, 0.25W, start-up resistor and a 10uF/25V VDD hold-up capacitor are enough for this application.

### Operating current

Operating current has been reduced to 3mA. The low operating current enables a better efficiency and reduces the requirement of VDD hold-up capacitance.

### Green Mode Operation

The patented green-mode function provides an off-time modulation to reduce the switching frequency in the light load and no load conditions. The on time is limited for better abnormal or brownout protection.  $V_{FB}$ , which is derived from the voltage feedback loop, is taken as the reference. Once  $V_{FB}$  is lower than the threshold voltage, switching frequency will be linearly decreased to the minimum green mode frequency around 10kHz ( $R_i = 26k\Omega$ ).

### Oscillator Operation

A resistor from RI pin to ground will generate a constant current source for SG6841. This current is used to charge an internal capacitor and hence the internal clock and switching frequency are determined. Increase the resistance will decrease the current source and reduce the switching frequency. A 26kΩ resistor  $R_i$  creates a 50uA constant current  $I_i$  and generates 65kHz switching frequency. The relation between  $R_i$  and switching frequency is:

$$f_{PWM} = \frac{1690}{R_i (k\Omega)} (kHz) \quad \text{----- (1)}$$

The range of the PWM oscillation frequency is designed as 50kHz ~ 90kHz.

### Current sensing and PWM current limiting

Peak current mode control is utilized in SG6841 to regulate output voltage and provide pulse by pulse current limiting. The switch current is detected by a sense resistor into the sense pin of SG6841. The PWM duty cycle is determined by this current sense signal and  $V_{FB}$ , the feedback voltage. When the voltage on sense pin reaches  $V_{COMP} = (V_{FB} - 1.0)/3$ , a switch cycle will be terminated immediately.  $V_{COMP}$  is internally clamped to a variable voltage around 0.85v for output power limit.

### Leading Edge Blanking

Each time when the power MOSFET is switched on, a turn-on spike will inevitably occur on the sense-resistor. To avoid premature termination of the switching pulse, a 270 nsec leading-edge blanking time is built in. Conventional RC filtering can therefore be omitted. During this blanking period, the current-limit comparator is disabled and it cannot switch off the gate driver.

### Under-voltage lockout (UVLO)

The turn-on and turn-off threshold of SG6841 are fixed internally at 16V/10V. During start-up, the hold-up capacitor must be charged to 16V through the start-up resistor so that SG6841 will be enabled. The hold-up capacitor will continue to supply  $V_{DD}$  before the energy can be delivered from auxiliary winding of the main transformer.  $V_{DD}$  must not drop below 10V during this start-up process. This UVLO hysteresis window insures that hold-up capacitor is adequate to supply  $V_{DD}$  during start-up.

### Gate Output / Soft Driving

The SG6841 BiCMOS output stage is a fast totem pole gate driver. Cross conduction has been avoided to minimize heat dissipation, increases efficiency and enhances reliability. The output driver is clamped by an internal 18V Zener diode in order to protect power MOSFET transistors against undesirable gate over voltage. A soft driving waveform is implemented to minimize EMI.

## Built-in Slope Compensation

The sensed voltage across the current sense resistor is used for current mode control and pulse-by-pulse current limiting. Built-in slope compensation will improve stability or prevent sub-harmonic oscillation of peak current mode control. SG6841 inserts a synchronized positive-going ramp at every switching cycle.  $V_{s-comp} = 0.33V$ .

## Constant Output Power Limit

When the SENSE voltage, across the sense resistor  $R_s$ , reaches the threshold voltage, around 1.0V, the output GATE drive will be turned off after a small propagation delay  $t_D$ . This propagation delay will introduce an additional current proportional to  $t_D \cdot V_{in} / L_p$ . Since the propagation delay is nearly constant regardless of the input line voltage  $V_{IN}$ . Higher input line voltage will result in a larger additional current and hence the output power limit is also higher than that under low input line voltage. To compensate this variation for wide AC input range, the threshold voltage is adjusted by the  $V_{IN}$  current. Since VIN pin is connected to the rectified input line voltage through the start-up resistor, a higher line voltage will generate higher  $V_{IN}$  current into the VIN pin. The threshold voltage is decreased if the  $V_{IN}$  current is increased. Smaller threshold voltage, forces the output GATE drive to terminate earlier, thus reduce the total PWM turn-on time and make the output power equal to that of low line input. This proprietary internal compensation ensures a constant output power limit for wide AC input voltage from 90VAC to 264VAC.

## ■ Thermal Protection

An NTC thermistor  $R_{ntc}$  in series with a resistor  $R_a$  can be connected from pin RT to ground. A constant current  $I_{RT}$  is output from pin RT. The voltage on RT pin can be expressed as  $V_{RT} = I_{RT} \times (R_{ntc} + R_a)$  in which  $I_{RT} = 2 \times (1.3V / R_i)$ .

At high ambient temperature,  $R_{ntc}$  will be smaller such that  $V_{RT}$  will decrease. When  $V_{RT}$  is less than 0.65V ( $V_{OTP,START}$ ), the PWM duty cycle will be decreased to lower the internal temperature of power supply. If the over heating situation still exists such that  $V_{RT}$  decreases further to 0.62V ( $V_{OTP,STOP}$ ), the PWM will be completely turned off.

## Limited Power Control

Every time when the output of power supply is shorted or over loaded, the FB voltage will increase. If the FB voltage is higher than a designed threshold, 4.2V, for longer than 31msec, the PWM output will then be turned off eternally.  $V_{DD}$ , the supply voltage for SG6841, will decrease due to the supply current for SG6841. When  $V_{DD}$  is lower than the turn-off threshold such as 10V, SG6841 will be totally shut down. Due to the start up resistor,  $V_{DD}$  will be charged up to the turn-on threshold voltage 16V until SG6841 is enabled again. If the over loading condition still exists, above protection will take place repeatedly. This will prevent the power supply from being overheated under over loading condition.

## Noise immunity

Noise on the current sense or control signal may cause significant pulse width jitter, particularly in the continuous conduction mode. Slope compensation helps alleviate this problem. Good placement and layout practices should be followed. Avoiding long PCB traces and component leads, locating compensation and filter components near to the SG6841, and increasing the power MOS gate resistance will always help.

**REFERENCE CIRCUIT**

**Circuit**

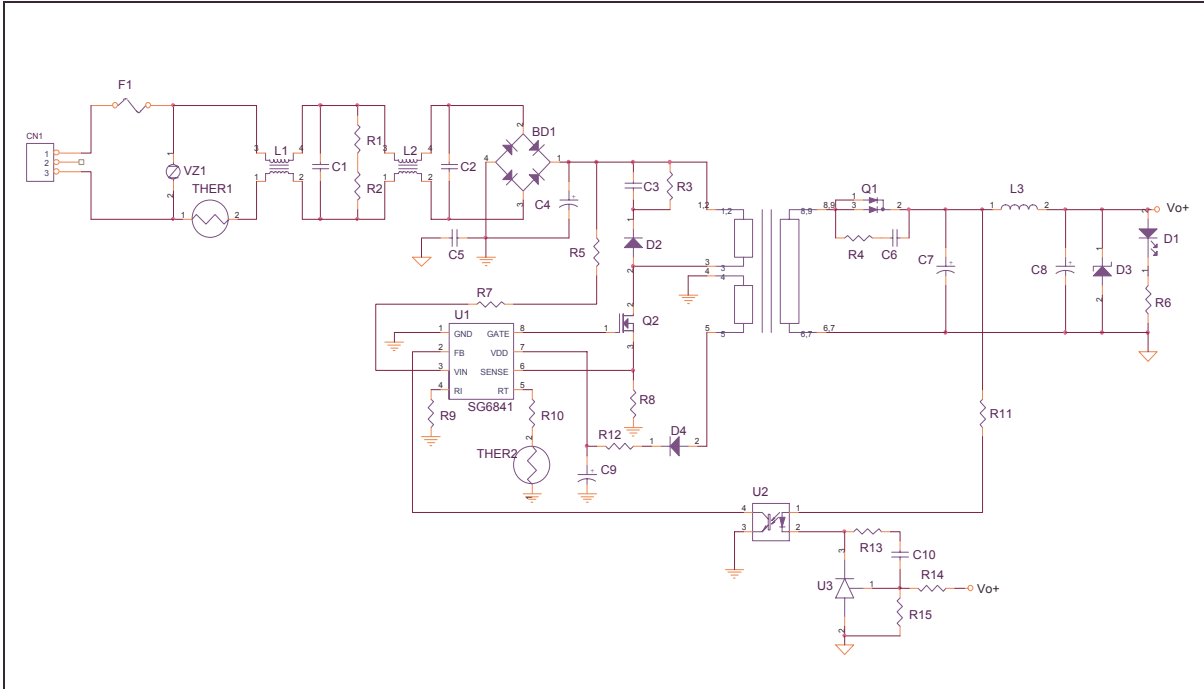

**BOM**

Reference	Component	Reference	Component
BD1	BD 4A/600V	R1,R2	R 1Mohm 1/4W
C1	XC 0.1uF/275V	R3	R 100Kohm 1/2W
C2	XC 0.22uF/275V	R4	R 47ohm 1/4W
C3	CC 0.01uF/500V	R5,R7	R 750Kohm 1/4W
C4	EC 120u/400V	R6	R 20Kohm 1/8W
C5	YC 222p/Y1	R8	R 0.3ohm 2W
C6	CC 1000pF/100V	R9	R 33Kohm 1/8W
C7	CC 1000pF/50V	R9	R 20Kohm 1/8W 1%
C8	EC 1000uF/35V	R11	R 220ohm 1/8W
C9	EC 220uF/35V	R12	R 4.7ohm 1/8W
D1	LED	R13	R 6.8Kohm 1/8W
D2	Diode FR157	R14	R 154Kohm 1/8W
D3	ZD 18V	R15	R 390Kohm 1/8W
D4	Diode FR102	THER1	Thermistor SCK054
F1	FUSE 4A/250V	T1	Transformer
L1	900uH	U1	IC SG6841
L2	15mH	U2	IC PC817
Q1	Diode 20A/100V	U3	IC TL431
Q2	MOS 7A/600V	VZ1	VZ 9G

**PACKAGE INFORMATION**

**8 PINS– DIP (D)**

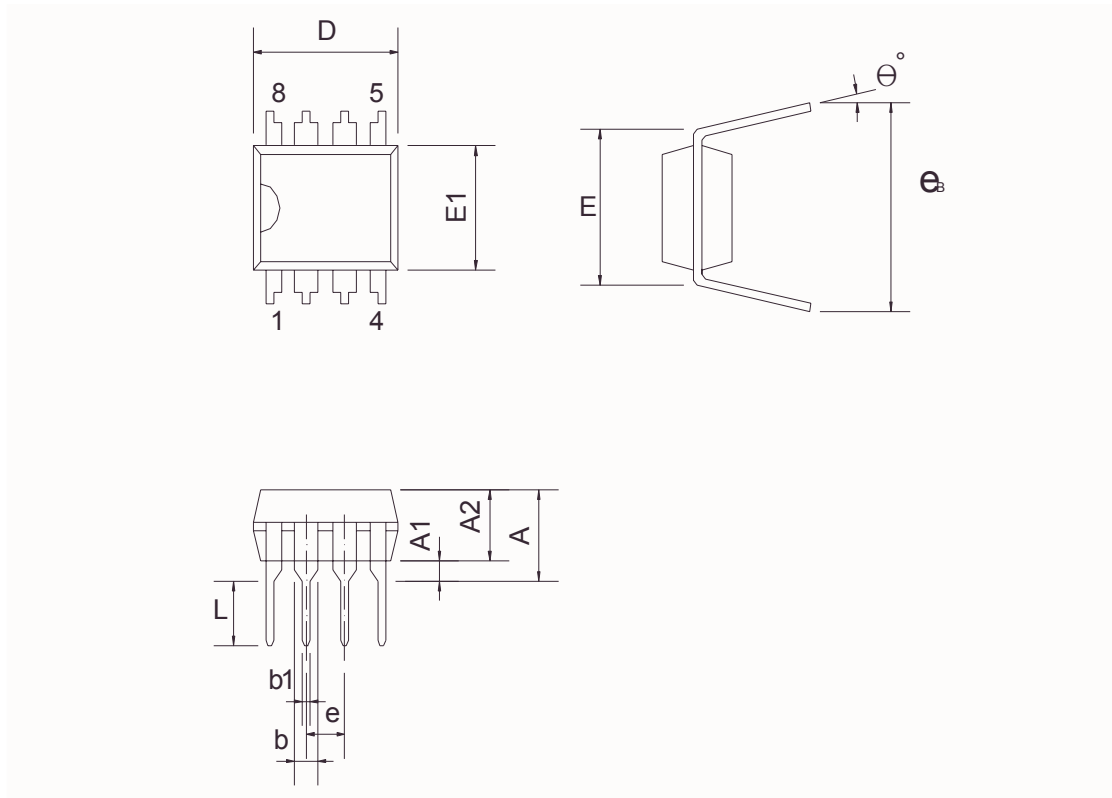

**Dimension**

Symbol	Millimeter			Inch		
	Min.	Typ.	Max.	Min.	Typ.	Max.
A			5.334			0.210
A1	0.381			0.015		
A2	3.175	3.302	3.429	0.125	0.130	0.135
b		1.524			0.060	
b1		0.457			0.018	
D	9.017	9.271	10.160	0.355	0.365	0.400
E		7.620			0.300	
E1	6.223	6.350	6.477	0.245	0.250	0.255
e		2.540			0.100	
L	2.921	3.302	3.810	0.115	0.130	0.150
e <sub>a</sub>	8.509	9.017	9.525	0.335	0.355	0.375
θ°	0°	7°	15°	0°	7°	15°

**8 PINS– SOP (S)**

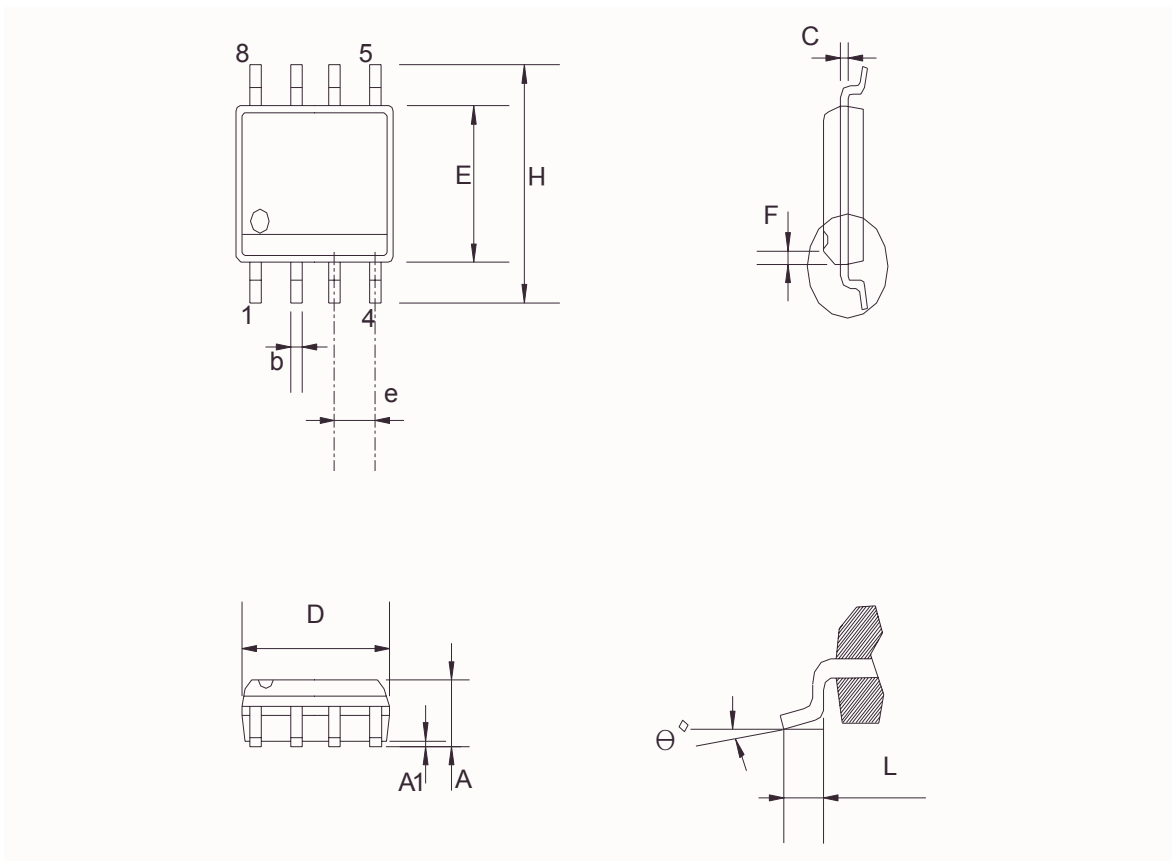

**Dimension**

Symbol	Millimeter			Inch		
	Min.	Typ.	Max.	Min.	Typ.	Max.
A	1.346		1.752	0.053		0.069
A1	0.101		0.254	0.004		0.010
b		0.406			0.016	
c		0.203			0.008	
D	4.648		4.978	0.183		0.196
E	0.381		3.987	0.150		0.157
e		1.270			0.050	
F		0.381X45°			0.015X45°	
H	5.791		6.197	0.228		0.244
L	0.406		1.270	0.016		0.050
θ°	0°		8°	0°		8°

## DISCLAIMERS

### LIFE SUPPORT

System General's products are not designed to be used as components in devices intended to support or sustain human life. Use of System General's products in components intended for surgical implant into the body, or other applications in which failure of the System General's products could create a situation where personal death or injury may occur, is not authorized without the express written approval of System General's Chief Executive Officer. System General will not be held liable for any damages or claims resulting from the use of its products in medical applications.

### MILITARY

System General's products are not designed for use in military applications. Use of System General's products in military applications is not authorized without the express written approval of System General's Chief Executive Officer. System General will not be held liable for any damages or claims resulting from the use of its products in military applications.

### RIGHT TO MAKE CHANGES

System General reserves the right to change this document and/or this product without notice. Customers are advised to consult their System General sales representative before ordering.