

4

3

2

1

THIS DRAWING IS UNPUBLISHED. RELEASED FOR PUBLICATION. ALL RIGHTS RESERVED.

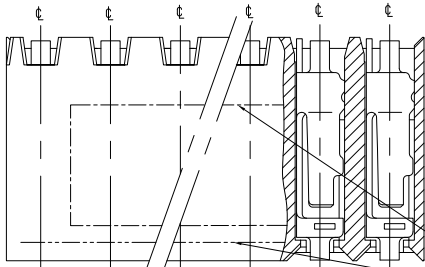

SECTION B-B/TOPVIEW

PART NO.	'N' POS. PER ROW	DIMENSIONS	
		A	B
216602-2	2	5.08	2.54
216602-3	3	7.62	5.08
216602-4	4	10.16	7.62
216602-5	5	12.70	10.16
216602-6	6	15.24	12.70
216602-7	7	17.78	15.24
216602-8	8	20.32	17.78
1-216602-0	10	25.40	22.86
1-216602-2	12	30.48	27.94
1-216602-3	13	33.02	30.48
1-216602-4	14	35.56	33.02
1-216602-6	16	40.64	38.10
2-216602-0	20	50.80	48.26
2-216602-3	23	58.42	55.88
2-216602-4	24	60.96	58.42
2-216602-6	26	66.04	63.50
2-216602-9	29	73.66	71.12
3-216602-1	31	78.74	76.20
3-216602-6	36	91.44	88.90
3-216602-8	38	96.52	93.98
5-216602-0	50	127.00	124.46
5-216602-1	51	128.54	127.00

LOC	DIST	REVISIONS		DATE	BY	APPD
IR	-	F	LR			
		H4		NOTE 7 CORRECTED		30JAN2012/MHM RP

NOTES:

- 1 TO DETERMINE DIMENSION TAKE N= NR. OF POS
FOR EXAMPLE, 10 POS., Nx2.54=25.4mm.
FOR ORDER NR. USE BASIC NR. + NR. OF POS.
FOR EXAMPLE, 2 POS.= 216602-2 (SHORTEST VERSION)
65 POS.= 6-216602-5 (LONGEST VERSION)
 - 2 HOUSING MATERIAL, GREEN GLASS FILLED POLYESTER, UL 94V-0
CONTACT MATERIAL, PHOSPHOR BRONZE.
 - 3 PLATING, UNDER COATING, 1.3µm Ni
AT CONTACT PLAGE, 0.8µm Au
AT SOLDER-TINES, 3.0-5.0µm TIN
 - 4 MATES WITH 0.63 SQUARE/ROUND MODU POSTS
 - 5 CONTACT POINT
 - 6 RECOMMENDED P.C.BOARD THICKNESS 1.6mm
- PRINTED: THE WORD "TE" [FOR 2 TO 6 POS]
THE WORD "TE" & PRODUCTION DATE [FOR 7 TO 12 POS]
THE WORD "TE", PRODUCTION DATE & BASIC PART NO. [FOR 13 TO 65 POS]
AND A DASHED LINE OVER THE LENGTH OF HOUSING TO
INDICATE CONTACT MATING SIDE.

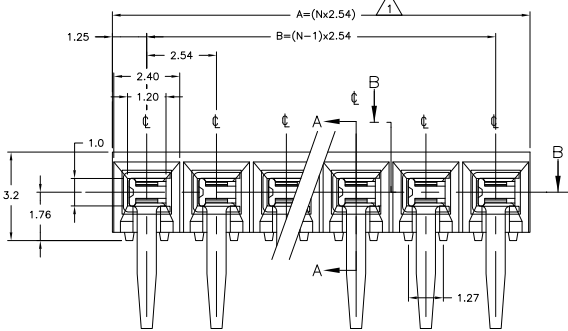

FRONT VIEW

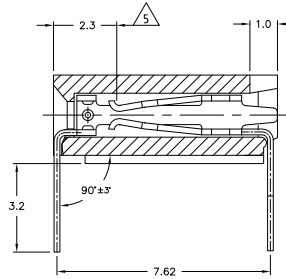

SECTION A-A

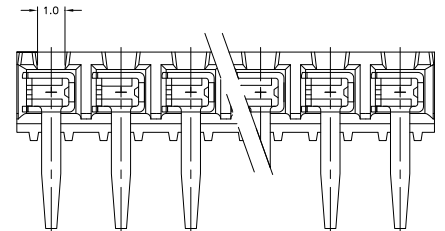

REAR VIEW

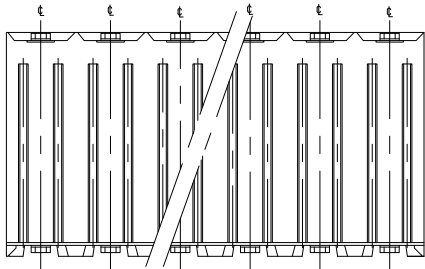

BOTTOM VIEW

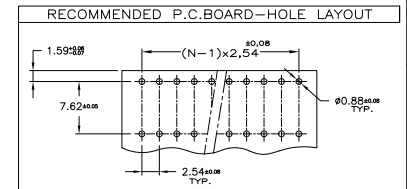

THIS DRAWING IS A CONTROLLED DOCUMENT. DIM: W.R. ANNOCKEE 19/12/91
CHK: R.T. DE BLIECK 19/12/91
APPD: R. SMETS 19/12/91
PRODUCT SPEC: 108-19072
APPLICATION SPEC: -
WEIGHT: -
CUSTOMER DRAWING

TE Connectivity
HV 190 HOR. ASS'Y SINGLE ROW
GOLD VERSION
(MAX. 65 POSITION)

SIZE: A2 CASE CODE: 00779 ©=216602
SCALE: 10:1 SHEET: 1 of 1 REV: H4

1471-9 (3/11)

30JAN2012