

LOC		DIST		REVISIONS			
F	LTR	DESCRIPTION	DATE	OWN	APVD		
	K1	REVISED PER ECO-11-005139	19MAR11	RK	HMR		

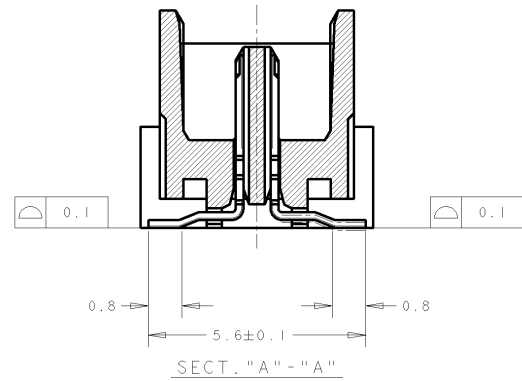
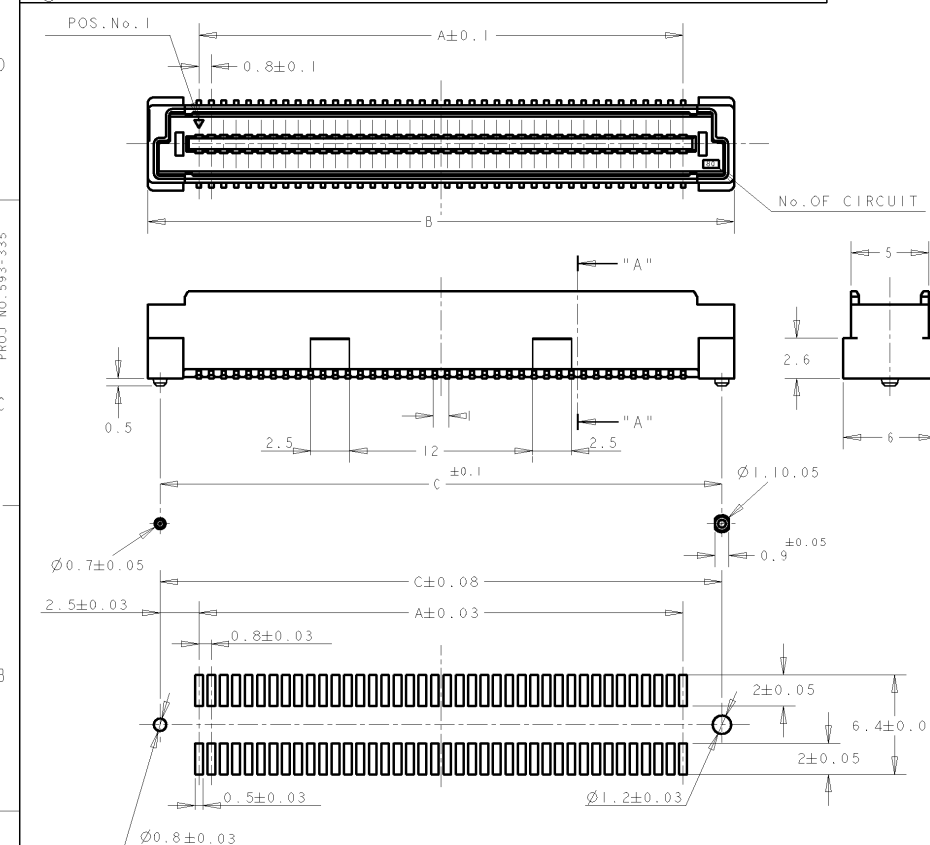

- NOTES:
- 1. MATERIAL; HOUSING: L.C.P. (HIGH TEMP THERMO PLASTIC)
UL 94V-0, NATURAL.
CONTACT: BRASS.
 - 2. FINISH: CONTACT AREA: 0.0002 MIN GOLD ON
0.0013 MIN ALL OVER NICKEL.
SOLDERING AREA: 0.001 MIN TIN-LEAD.
 - 3. POSITION SERIES: SEE TABLE.
 - 4. CONN STACK HEIGHT COMBINE OF PLUG "Y" H VS REC "X" H.
STACK HEIGHT = Y + X - 5

P/N SEE SHEET 2 OF 2.

RECOMMENDED P.C. BOARD LAYOUT

DIMENSIONS: mm		TOLERANCES UNLESS OTHERWISE SPECIFIED:		DWN 30MAR93 T. KUSUHARA CHK I. ENOMOTO APVD ERIC TNG PRODUCT SPEC APPLICATION SPEC WEIGHT CUSTOMER DRAWING		30MAR93 30MAR93 NAME PLUG ASSEMBLY 6H TYPE (0.5 BOSS LENGTH) FOR FH 0.8mm PITCH B-T-B CONNECTOR		TE Connectivity	
0 PLC ± 1 PLC ±0.20 2 PLC ±0.25 3 PLC ±0.30 4 PLC ± ANGLES ±°		FINISH		SIZE A3 CAGE CODE 00779 DRAWING NO. C-179029		SCALE 4:1 SHEET 1 OF 2 REV K1			

4

3

2

1

THIS DRAWING IS UNPUBLISHED.

RELEASED FOR PUBLICATION

19

COPYRIGHT BY ALL RIGHTS RESERVED.

LOC	DIST	REVISIONS			
F	LTR	DESCRIPTION	DATE	OWN	APVD
DY	-	- SEE SHEET 1 OF 2	-	-	-

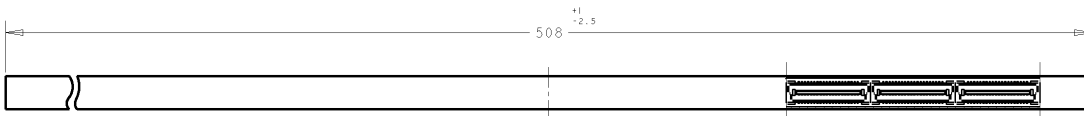

SECT A-A



REFERENCE PICTURE OF TUBE PACK

SECT B-B

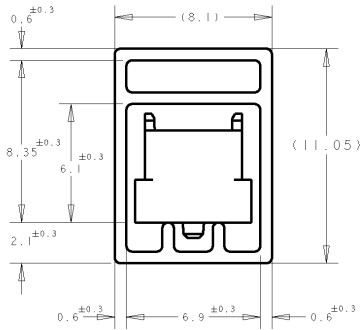
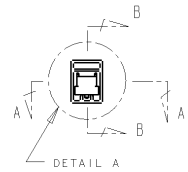

DETAIL "B"
(SCALE 5-1)

5	84.2	85.8	79.2	200	I-	-0
6	76.2	77.8	71.2	180		-9
6	68.2	69.8	63.2	160		-8
7	60.2	61.8	55.2	140		-6
9	52.2	53.8	47.2	120		-5
10	44.2	45.8	39.2	100		-4
12	36.2	37.8	31.2	80		-3
16	28.2	29.8	23.2	60		-2
22	20.2	21.8	15.2	40		179029-1
QTY/ TUBE	C	B	A	POS.	CONN	P/N

DIMENSIONS: mm		TOLERANCES UNLESS OTHERWISE SPECIFIED:		DWN T. KUSUHARA 30MAR93 CHK I. ENOMOTO 30MAR93			
		0 PLC ± 1 PLC ±0.20 2 PLC ±0.25 3 PLC ±0.30 4 PLC ± ANGLES ±°		APVD ERIC TNG		NAME PLUG ASSEMBLY 6H TYPE (0.5 BOSS LENGTH) FOR FH 0.8mm PITCH B-T-B CONNECTOR	
MATERIAL 		FINISH 		PRODUCT SPEC - APPLICATION SPEC - WEIGHT -		SIZE A3	
CUSTOMER DRAWING				CAGE CODE 00779		DRAWING NO. C-179029	
				SCALE -		SHEET 2 OF 2	
				REV K1			