

THIS DRAWING IS UNPUBLISHED
 ALL RIGHTS RESERVED

REVISES		DATE	BY	APP'D
AD	00			

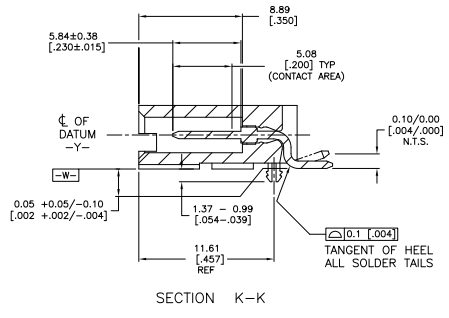

- △ HOUSING: HIGH TEMPERATURE THERMOPLASTIC, COLOR-BLACK.
 POST: BRASS.
- △ POST: 0.00254-0.00508 [000100-.00200] BRIGHT TIN-LEAD OVER
 0.00127-0.00254 [000050-.000100] NICKEL.
- △ DATUMS AND BASIC DIMENSIONS ESTABLISHED BY THE CUSTOMER.
- △ TWO POLARIZATION SLOTS ON ASSEMBLIES WITH FOUR OR MORE
 POSITIONS.
- △ 0.00254-0.00508 [000100-.000200] BRIGHT TIN OVER
 0.00127-0.00254 [000050-.000100] NICKEL.
- △ PRELIMINARY PART - NOT RELEASED FOR PRODUCTION.
- △ 0.00254-0.00508 [000100-.000200] MATTE TIN OVER
 0.00127-0.00254 [000050-.000100] NICKEL.

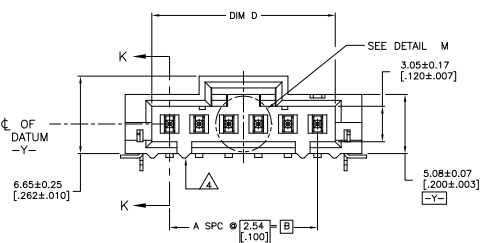
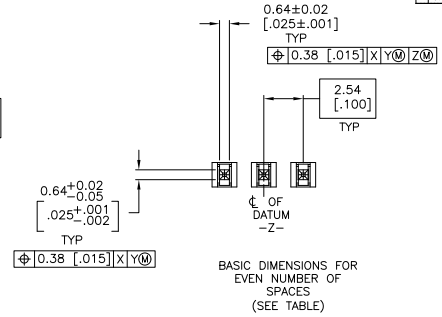
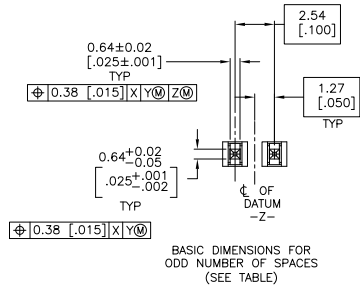
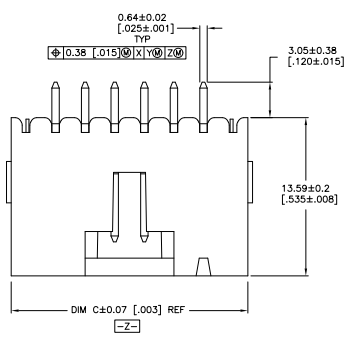
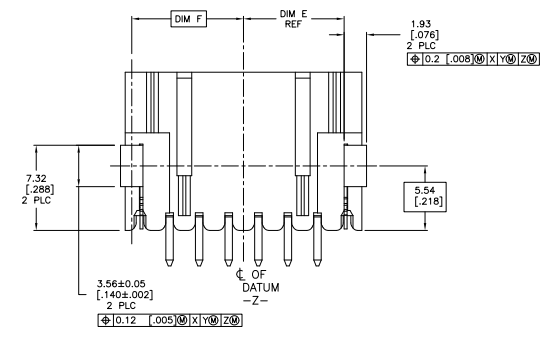

SEE TABLE ON
 SHEET #3

THIS DRAWING IS A CONTROLLED DOCUMENT.		DATE	BY	REVISED PER	DATE	BY
DRAWING NO. 108-25034		DATE	BY	REVISED PER	DATE	BY
CUSTOMER DRAWING		DATE	BY	REVISED PER	DATE	BY
SEE TABLE		DATE	BY	REVISED PER	DATE	BY

TE Connectivity

TE CONNECTIVITY
 108-25034
 108-25034
 108-25034
 108-25034

HEADER ASSEMBLY, LATCHING, RIGHT
 ANGLE SURFACE MOUNT, WTE,
 AMPHIBIOUS

DATE: 10/11/00
 BY: J1
 REVISED PER: 11/11/01
 BY: HMR

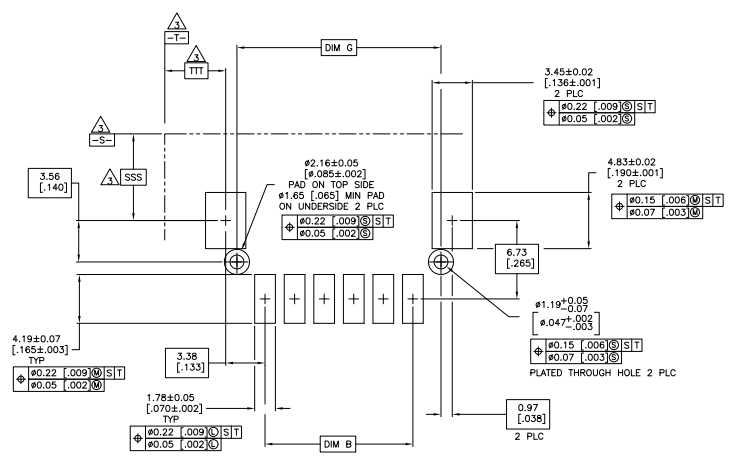

RECOMMENDED PC BOARD LAYOUT

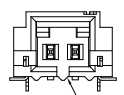

POLARIZATION SLOT FOR TWO POSITION

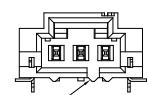

POLARIZING SLOT FOR THREE POSITION

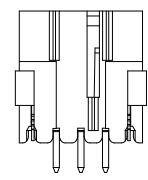
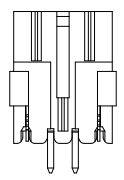

THIS DRAWING IS A CONTROLLED DOCUMENT.		REV	DATE	TE TE Connectivity
DRAWING LABEL:		BY	DATE	
UNLESS OTHERWISE SPECIFIED:	UNLESS OTHERWISE SPECIFIED:	BY	DATE	108-25034
1. DIMENSIONS ARE IN INCHES	2. DIMENSIONS ARE IN MILLIMETERS	BY	DATE	108-25034
3. DIMENSIONS ARE IN MILLIMETERS	4. DIMENSIONS ARE IN INCHES	BY	DATE	108-25034
5. DIMENSIONS ARE IN MILLIMETERS	6. DIMENSIONS ARE IN INCHES	BY	DATE	108-25034
7. DIMENSIONS ARE IN MILLIMETERS	8. DIMENSIONS ARE IN INCHES	BY	DATE	108-25034
9. DIMENSIONS ARE IN MILLIMETERS	10. DIMENSIONS ARE IN INCHES	BY	DATE	108-25034
11. DIMENSIONS ARE IN MILLIMETERS	12. DIMENSIONS ARE IN INCHES	BY	DATE	108-25034
13. DIMENSIONS ARE IN MILLIMETERS	14. DIMENSIONS ARE IN INCHES	BY	DATE	108-25034
15. DIMENSIONS ARE IN MILLIMETERS	16. DIMENSIONS ARE IN INCHES	BY	DATE	108-25034
17. DIMENSIONS ARE IN MILLIMETERS	18. DIMENSIONS ARE IN INCHES	BY	DATE	108-25034
19. DIMENSIONS ARE IN MILLIMETERS	20. DIMENSIONS ARE IN INCHES	BY	DATE	108-25034
21. DIMENSIONS ARE IN MILLIMETERS	22. DIMENSIONS ARE IN INCHES	BY	DATE	108-25034
23. DIMENSIONS ARE IN MILLIMETERS	24. DIMENSIONS ARE IN INCHES	BY	DATE	108-25034
25. DIMENSIONS ARE IN MILLIMETERS	26. DIMENSIONS ARE IN INCHES	BY	DATE	108-25034
27. DIMENSIONS ARE IN MILLIMETERS	28. DIMENSIONS ARE IN INCHES	BY	DATE	108-25034
29. DIMENSIONS ARE IN MILLIMETERS	30. DIMENSIONS ARE IN INCHES	BY	DATE	108-25034
31. DIMENSIONS ARE IN MILLIMETERS	32. DIMENSIONS ARE IN INCHES	BY	DATE	108-25034
33. DIMENSIONS ARE IN MILLIMETERS	34. DIMENSIONS ARE IN INCHES	BY	DATE	108-25034
35. DIMENSIONS ARE IN MILLIMETERS	36. DIMENSIONS ARE IN INCHES	BY	DATE	108-25034
37. DIMENSIONS ARE IN MILLIMETERS	38. DIMENSIONS ARE IN INCHES	BY	DATE	108-25034
39. DIMENSIONS ARE IN MILLIMETERS	40. DIMENSIONS ARE IN INCHES	BY	DATE	108-25034
41. DIMENSIONS ARE IN MILLIMETERS	42. DIMENSIONS ARE IN INCHES	BY	DATE	108-25034
43. DIMENSIONS ARE IN MILLIMETERS	44. DIMENSIONS ARE IN INCHES	BY	DATE	108-25034
45. DIMENSIONS ARE IN MILLIMETERS	46. DIMENSIONS ARE IN INCHES	BY	DATE	108-25034
47. DIMENSIONS ARE IN MILLIMETERS	48. DIMENSIONS ARE IN INCHES	BY	DATE	108-25034
49. DIMENSIONS ARE IN MILLIMETERS	50. DIMENSIONS ARE IN INCHES	BY	DATE	108-25034
51. DIMENSIONS ARE IN MILLIMETERS	52. DIMENSIONS ARE IN INCHES	BY	DATE	108-25034
53. DIMENSIONS ARE IN MILLIMETERS	54. DIMENSIONS ARE IN INCHES	BY	DATE	108-25034
55. DIMENSIONS ARE IN MILLIMETERS	56. DIMENSIONS ARE IN INCHES	BY	DATE	108-25034
57. DIMENSIONS ARE IN MILLIMETERS	58. DIMENSIONS ARE IN INCHES	BY	DATE	108-25034
59. DIMENSIONS ARE IN MILLIMETERS	60. DIMENSIONS ARE IN INCHES	BY	DATE	108-25034
61. DIMENSIONS ARE IN MILLIMETERS	62. DIMENSIONS ARE IN INCHES	BY	DATE	108-25034
63. DIMENSIONS ARE IN MILLIMETERS	64. DIMENSIONS ARE IN INCHES	BY	DATE	108-25034
65. DIMENSIONS ARE IN MILLIMETERS	66. DIMENSIONS ARE IN INCHES	BY	DATE	108-25034
67. DIMENSIONS ARE IN MILLIMETERS	68. DIMENSIONS ARE IN INCHES	BY	DATE	108-25034
69. DIMENSIONS ARE IN MILLIMETERS	70. DIMENSIONS ARE IN INCHES	BY	DATE	108-25034
71. DIMENSIONS ARE IN MILLIMETERS	72. DIMENSIONS ARE IN INCHES	BY	DATE	108-25034
73. DIMENSIONS ARE IN MILLIMETERS	74. DIMENSIONS ARE IN INCHES	BY	DATE	108-25034
75. DIMENSIONS ARE IN MILLIMETERS	76. DIMENSIONS ARE IN INCHES	BY	DATE	108-25034
77. DIMENSIONS ARE IN MILLIMETERS	78. DIMENSIONS ARE IN INCHES	BY	DATE	108-25034
79. DIMENSIONS ARE IN MILLIMETERS	80. DIMENSIONS ARE IN INCHES	BY	DATE	108-25034
81. DIMENSIONS ARE IN MILLIMETERS	82. DIMENSIONS ARE IN INCHES	BY	DATE	108-25034
83. DIMENSIONS ARE IN MILLIMETERS	84. DIMENSIONS ARE IN INCHES	BY	DATE	108-25034
85. DIMENSIONS ARE IN MILLIMETERS	86. DIMENSIONS ARE IN INCHES	BY	DATE	108-25034
87. DIMENSIONS ARE IN MILLIMETERS	88. DIMENSIONS ARE IN INCHES	BY	DATE	108-25034
89. DIMENSIONS ARE IN MILLIMETERS	90. DIMENSIONS ARE IN INCHES	BY	DATE	108-25034
91. DIMENSIONS ARE IN MILLIMETERS	92. DIMENSIONS ARE IN INCHES	BY	DATE	108-25034
93. DIMENSIONS ARE IN MILLIMETERS	94. DIMENSIONS ARE IN INCHES	BY	DATE	108-25034
95. DIMENSIONS ARE IN MILLIMETERS	96. DIMENSIONS ARE IN INCHES	BY	DATE	108-25034
97. DIMENSIONS ARE IN MILLIMETERS	98. DIMENSIONS ARE IN INCHES	BY	DATE	108-25034
99. DIMENSIONS ARE IN MILLIMETERS	100. DIMENSIONS ARE IN INCHES	BY	DATE	108-25034

THIS DRAWING IS UNPUBLISHED
 ALL RIGHTS RESERVED

REVISED		REVISIONS		
REV	DATE	DESCRIPTION	BY	APPD
AD	00	-	-	-
SEE SHEET 1				

△	44	17.53 [.690]	9.60 [.378]	8.64 [.340]	15.75 [.620]	20.32 [.800]	12.70 [.500]	5	6	2-147324-7
△	44	27.69 [1.090]	14.68 [.578]	13.72 [.540]	25.91 [1.020]	30.48 [1.200]	22.86 [.900]	9	10	2-147324-6
△	24	7.37 [.290]	4.52 [.178]	3.56 [.140]	5.59 [.220]	10.16 [.400]	2.54 [.100]	1	2	2-147324-5
△	88	65.79 [2.590]	33.73 [1.328]	32.77 [1.290]	64.01 [2.520]	68.58 [2.700]	60.96 [2.400]	24	25	2-147324-4
△	88	63.25 [2.490]	32.46 [1.278]	31.50 [1.240]	61.47 [2.420]	66.04 [2.600]	58.42 [2.300]	23	24	2-147324-3
△	88	60.71 [2.390]	31.19 [1.228]	30.23 [1.190]	58.93 [2.320]	63.50 [2.500]	55.88 [2.200]	22	23	2-147324-2
△	88	58.17 [2.290]	29.92 [1.178]	28.96 [1.140]	56.39 [2.220]	60.96 [2.400]	53.34 [2.100]	21	22	2-147324-1
△	88	55.63 [2.190]	28.65 [1.128]	27.69 [1.090]	53.85 [2.120]	58.42 [2.300]	50.80 [2.000]	20	21	2-147324-0
△	72	53.09 [2.090]	27.38 [1.078]	26.42 [1.040]	51.31 [2.020]	55.88 [2.200]	48.26 [1.900]	19	20	1-147324-9
△	72	50.55 [1.990]	26.11 [1.028]	25.15 [.990]	48.77 [1.920]	53.34 [2.100]	45.72 [1.800]	18	19	1-147324-8
△	72	48.01 [1.890]	24.84 [.978]	23.88 [.940]	46.23 [1.820]	50.80 [2.000]	43.18 [1.700]	17	18	1-147324-7
△	72	45.47 [1.790]	23.57 [.928]	22.61 [.890]	43.69 [1.720]	48.26 [1.900]	40.64 [1.600]	16	17	1-147324-6
△	72	42.93 [1.690]	22.30 [.878]	21.34 [.840]	41.15 [1.620]	45.72 [1.800]	38.10 [1.500]	15	16	1-147324-5
△	72	40.39 [1.590]	21.03 [.828]	20.07 [.790]	38.61 [1.520]	43.18 [1.700]	35.56 [1.400]	14	15	1-147324-4
△	56	37.85 [1.490]	19.76 [.778]	18.80 [.740]	36.07 [1.420]	40.64 [1.600]	33.02 [1.300]	13	14	1-147324-3
△	56	35.31 [1.390]	18.49 [.728]	17.53 [.690]	33.53 [1.320]	38.10 [1.500]	30.48 [1.200]	12	13	1-147324-2
△	56	32.77 [1.290]	17.22 [.678]	16.26 [.640]	30.99 [1.220]	35.56 [1.400]	27.94 [1.100]	11	12	1-147324-1
△	56	30.23 [1.190]	15.95 [.628]	14.99 [.590]	28.45 [1.120]	33.02 [1.300]	25.40 [1.000]	10	11	1-147324-0
△	44	27.69 [1.090]	14.68 [.578]	13.72 [.540]	25.91 [1.020]	30.48 [1.200]	22.86 [.900]	9	10	147324-9
△	44	25.15 [.990]	13.41 [.528]	12.45 [.490]	23.37 [.920]	27.94 [1.100]	20.32 [.800]	8	9	147324-8
△	44	22.61 [.890]	12.14 [.478]	11.18 [.440]	20.83 [.820]	25.40 [1.000]	17.78 [.700]	7	8	147324-7
△	44	20.07 [.790]	10.87 [.428]	9.91 [.390]	18.29 [.720]	22.86 [.900]	15.24 [.600]	6	7	147324-6
△	44	17.53 [.690]	9.60 [.378]	8.64 [.340]	15.75 [.620]	20.32 [.800]	12.70 [.500]	5	6	147324-5
△	32	14.99 [.590]	8.33 [.328]	7.37 [.290]	13.21 [.520]	17.78 [.700]	10.16 [.400]	4	5	147324-4
△	24	12.45 [.490]	7.06 [.278]	6.10 [.240]	10.67 [.420]	15.24 [.600]	7.62 [.300]	3	4	147324-3
△	24	9.91 [.390]	5.79 [.228]	4.83 [.190]	8.13 [.320]	12.70 [.500]	5.08 [.200]	2	3	147324-2
△	24	7.37 [.290]	4.52 [.178]	3.56 [.140]	5.59 [.220]	10.16 [.400]	2.54 [.100]	1	2	147324-1
PLATING	EIA 481 TAPE WIDTH mm	G	F	E	D	C	B	A	NO OF POSN	PART NUMBER

THIS DRAWING IS A CONTROLLED DOCUMENT.

DESIGNER: [blank] CHECKED: [blank] DATE: [blank]

APPROVED: [blank]

DATE: [blank] TIME: [blank]

108-25034

TE Connectivity

HEADER ASSEMBLY, LATCHING, RIGHT ANGLE SURFACE MOUNT, WTE, AMPRODU

DATE: [blank] TIME: [blank]

100779

147324

CUSTOMER DRAWING

1:1 3 4 11

THIS DRAWING IS UNPUBLISHED
 ALL RIGHTS RESERVED

REVISE		REVISIONS	
NO.	DATE	DESCRIPTION	BY
AD	00	SEE SHEET 1	-

△	88	65.79 [2.590]	33.73 [1.328]	32.77 [1.290]	64.01 [2.520]	68.58 [2.700]	60.96 [2.400]	24	25	7-147324-4
△	88	63.25 [2.490]	32.46 [1.278]	31.50 [1.240]	61.47 [2.420]	66.04 [2.600]	58.42 [2.300]	23	24	7-147324-3
△	88	60.71 [2.390]	31.19 [1.228]	30.23 [1.190]	58.93 [2.320]	63.50 [2.500]	55.88 [2.200]	22	23	7-147324-2
△	88	58.17 [2.290]	29.92 [1.178]	28.96 [1.140]	56.39 [2.220]	60.96 [2.400]	53.34 [2.100]	21	22	7-147324-1
△	88	55.63 [2.190]	28.65 [1.128]	27.69 [1.090]	53.85 [2.120]	58.42 [2.300]	50.80 [2.000]	20	21	7-147324-0
△	72	53.09 [2.090]	27.38 [1.078]	26.42 [1.040]	51.31 [2.020]	55.88 [2.200]	48.26 [1.900]	19	20	6-147324-9
△	72	50.55 [1.990]	26.11 [1.028]	25.15 [.990]	48.77 [1.920]	53.34 [2.100]	45.72 [1.800]	18	19	6-147324-8
△	72	48.01 [1.890]	24.84 [.978]	23.88 [.940]	46.23 [1.820]	50.80 [2.000]	43.18 [1.700]	17	18	6-147324-7
△	72	45.47 [1.790]	23.57 [.928]	22.61 [.890]	43.69 [1.720]	48.26 [1.900]	40.64 [1.600]	16	17	6-147324-6
△	72	42.93 [1.690]	22.30 [.878]	21.34 [.840]	41.15 [1.620]	45.72 [1.800]	38.10 [1.500]	15	16	6-147324-5
△	72	40.39 [1.590]	21.03 [.828]	20.07 [.790]	38.61 [1.520]	43.18 [1.700]	35.56 [1.400]	14	15	6-147324-4
△	56	37.85 [1.490]	19.76 [.778]	18.80 [.740]	36.07 [1.420]	40.64 [1.600]	33.02 [1.300]	13	14	6-147324-3
△	56	35.31 [1.390]	18.49 [.728]	17.53 [.690]	33.53 [1.320]	38.10 [1.500]	30.48 [1.200]	12	13	6-147324-2
△	56	32.77 [1.290]	17.22 [.678]	16.26 [.640]	30.99 [1.220]	35.56 [1.400]	27.94 [1.100]	11	12	6-147324-1
△	56	30.23 [1.190]	15.95 [.628]	14.99 [.590]	28.45 [1.120]	33.02 [1.300]	25.40 [1.000]	10	11	6-147324-0
△	44	27.69 [1.090]	14.68 [.578]	13.72 [.540]	25.91 [1.020]	30.48 [1.200]	22.86 [.900]	9	10	5-147324-9
△	44	25.15 [.990]	13.41 [.528]	12.45 [.490]	23.37 [.920]	27.94 [1.100]	20.32 [.800]	8	9	5-147324-8
△	44	22.61 [.890]	12.14 [.478]	11.18 [.440]	20.83 [.820]	25.40 [1.000]	17.78 [.700]	7	8	5-147324-7
△	44	20.07 [.790]	10.87 [.428]	9.91 [.390]	18.29 [.720]	22.86 [.900]	15.24 [.600]	6	7	5-147324-6
△	44	17.53 [.690]	9.60 [.378]	8.64 [.340]	15.75 [.620]	20.32 [.800]	12.70 [.500]	5	6	5-147324-5
△	32	14.99 [.590]	8.33 [.328]	7.37 [.290]	13.21 [.520]	17.78 [.700]	10.16 [.400]	4	5	5-147324-4
△	24	12.45 [.490]	7.06 [.278]	6.10 [.240]	10.67 [.420]	15.24 [.600]	7.62 [.300]	3	4	5-147324-3
△	24	9.91 [.390]	5.79 [.228]	4.83 [.190]	8.13 [.320]	12.70 [.500]	5.08 [.200]	2	3	5-147324-2
△	24	7.37 [.290]	4.52 [.178]	3.56 [.140]	5.59 [.220]	10.16 [.400]	2.54 [.100]	1	2	5-147324-1
PLATING	EIA 481 TAPE WIDTH mm	G	F	E	D	C	B	A	NO OF POSN	PART NUMBER

THIS DRAWING IS A CONTROLLED DOCUMENT.		DESIGNER: [Signature]	DATE: 10B-25034	REVISED BY: [Signature]	DATE: 10B-25034
DRAWN BY: [Signature]		CHECKED BY: [Signature]		DATE: 10B-25034	
SCALE: SEE TABLE		MATERIAL: CUSTOMER DRAWING		DRAWING NO: 147324	
SHEET: 1		TOTAL SHEETS: 4		REV: 4	

TE Connectivity
 HEADER ASSEMBLY, LATCHING, RIGHT
 ANGLE SURFACE MOUNT, WTE, AMPHOUDY