Interconnection System. AMPMODU* System 50

1. SCOPE

1.1. Content

This specification covers performance, tests and quality requirements for AMPMODU* System 50 interconnection system including through hole and surface mount connectors. This miniature board-to-board system consists of receptacles and .015 inch square post headers on .050 by .100 inch centerline interface spacing; .050 inch between circuits within a row and .100 inch between rows. Surface mount headers and receptacles are designed to be soldered to the surface of printed wiring boards having pads with pre-applied solder paste. Conventional processes shall be used in placing and reflowing solder paste as defined in applicable documents. This specification applies when receptacles and/or headers are mounted to G-10 or FR-4 epoxy printed wiring boards.*

1.2. Qualification

When tests are performed on subject product line, procedures specified in 109 Series Test Specifications shall be used. All inspections shall be performed using applicable inspection plan and product drawing.

2. APPLICABLE DOCUMENTS

The following documents form a part of this specification to the extent specified herein. Unless otherwise specified, latest edition of the document applies. In the event of conflict between requirements of this specification and product drawing, product drawing shall take precedence. In the event of conflict between requirements of this specification and referenced documents, this specification shall take precedence.

2.1. TE Connectivity (TE) Documents

- 109-1: General Requirements for Test Specifications
- 109 Series: Test Specifications as indicated in Figure 1
- 114-25031: Application Specification
- 114-25035: Application Specification
- 501-287: Qualification Test Report

3. REQUIREMENTS

3.1. Design and Construction

Product shall be of design, construction and physical dimensions specified on applicable product drawing.

3.2. Materials

- Contact:
 - Header: Phosphor bronze, gold plating on mating area, tin-lead plating on tails
 - Receptacle: Phosphor bronze, gold plating on mating area, tin-lead plating on tails
- Holddowns: Copper alloy, tin-lead plating
- Housing: Black thermoplastic, UL94V-0

3.3. Ratings

- Voltage: 30 volts AC
- Current: See Figures 4A and 4B for applicable current carrying capability
- Temperature: -65 to 105°C

3.4. Performance and Test Description

Product is designed to meet electrical, mechanical and environmental performance requirements specified in Figure 1. Unless otherwise specified, all tests shall be performed at ambient environmental conditions per Test Specification 109-1.

3.5. Test Requirements and Procedures Summary

Test Description	Requirement	Procedure
Examination of product.	Meets requirements of product drawing and Application Specifications 114-25031 and 114-25035.	Visual, dimensional and functional per applicable quality inspection plan.
ELECTRICAL		
Termination resistance.	15 milliohms maximum initial. ΔR 4 milliohms maximum.	TE 109-6-1. Subject mated contacts assembled in housing to 50 mv maximum open circuit at 100 ma maximum. See Figure 3.
Insulation resistance.	5000 megohms minimum initial. 1000 megohms minimum final.	TE Spec 109-28-4. Test between adjacent contacts of mated samples.
Dielectric withstanding voltage.	500 vac at sea level.	TE Spec 109-29-1. Test between adjacent contacts of mated samples.
Temperature rise vs current.	30°C maximum temperature rise at specified current.	TE Spec 109-45-1. Measure temperature rise vs current. See Figure 4.
MECHANICAL		
Vibration, sinusoidal.	No discontinuities of 1 microsecond or longer duration. See Note.	TE Spec 109-21-3. Subject mated samples to 15 G's between 10-2000-10 Hz traversed in 20 minutes in each of 3 mutually perpendicular planes. See Figure 5.
Physical shock.	No discontinuities of 1 microsecond or longer duration. See Note.	TE Spec 109-26-9. Subject mated samples to 100 G's sawtooth shock pulses of 6 milliseconds duration. 3 shocks in each direction applied along 3 mutually perpendicular planes, 18 total shocks. See Figure 5.

Figure 1 (continued)

Test Description	Requirement	Procedure
Durability.	See Note.	TE Spec 109-27. Mate and unmate samples for 200 cycles at maximum rate of 150 cycles per hour.
Contact retention.	Contacts shall not dislodge.	TE Spec 109-30. Apply axial load of 2 pounds to contacts in mating direction.
Mating force.	5 ounces maximum per contact.	TE Spec 109-42, Condition A. Measure force necessary to mate samples a distance of .100 inch from point of initial contact at maximum rate of .5 inch per minute.
Unmating force.	.8 ounce minimum per contact.	TE Spec 109-42, Condition A. Measure force necessary to unmate samples at maximum rate of .5 inch per minute.
ENVIRONMENTAL		
Thermal shock.	See Note.	TE Spec 109-22. Subject mated samples to 5 cycles between -65 and 105°C.
Humidity-temperature cycling.	See Note.	TE Spec 109-23-4, Condition B. Subject mated samples to 10 cycles between 25 and 65°C at 95% RH.
Temperature life.	See Note.	TE Spec 109-43. Subject mated samples to temperature life at 118°C for 792 hours.
Mixed flowing gas.	See Note.	TE Spec 109-85-3. Subject mated samples to environmental class III for 20 days.

NOTE

Shall meet visual requirements, show no physical damage and shall meet requirements of additional tests as specified in Test Sequence in Figure 2.

Figure 1 (end)

3.6. Product Qualification and Requalification Test Sequence

Test or Examination	Test Group (a)			
	1	2	3	4
	Test Sequence (b)			
Examination of product	1,9	1,9	1,8	1,3
Termination resistance	3,7	2,7		
Insulation resistance			2,6	
Dielectric withstanding voltage			3,7	
Temperature rise vs current		3,8		
Vibration	5	6(c)		
Physical shock	6			
Durability	4			
Contact retention				2
Mating force	2			
Unmating force	8			
Thermal shock			4	
Humidity-temperature cycling			5	
Temperature life		5		
Mixed flowing gas		4(d)		

NOTE

- (a) See paragraph 4.1.A.
- (b) Numbers indicate sequence in which tests are performed.
- (c) Discontinuities shall not be measured. Energize at 18 °C level for 100% loadings per Test Specification 109-151.
- (d) Precondition samples with 10 cycles durability.

Figure 2

4. QUALITY ASSURANCE PROVISIONS

4.1. Qualification Testing

A. Sample Selection

Samples shall be prepared in accordance with applicable Instruction Sheets and shall be selected at random from current production. All test groups shall consist of the longest position size of a right angle receptacle and right angle unshrouded header. Test groups 1 and 3 shall each consist of 5 samples. Test group 2 shall consist of 3 samples. Test group 4 shall consist of 5 samples not mounted to printed circuit boards.

B. Test Sequence

Qualification inspection shall be verified by testing samples as specified in Figure 2.

4.2. Requalification Testing

If changes significantly affecting form, fit or function are made to product or manufacturing process, product assurance shall coordinate requalification testing, consisting of all or part of original testing sequence as determined by development/product, quality and reliability engineering.

4.3. Acceptance

Acceptance is based on verification that product meets requirements of Figure 1. Failures attributed to equipment, test setup or operator deficiencies shall not disqualify product. When product failure occurs, corrective action shall be taken and samples resubmitted for qualification. Testing to confirm corrective action is required before resubmittal.

4.4. Quality Conformance Inspection

The applicable quality inspection plan will specify sampling acceptable quality level to be used. Dimensional and functional requirements shall be in accordance with applicable product drawing and this specification.

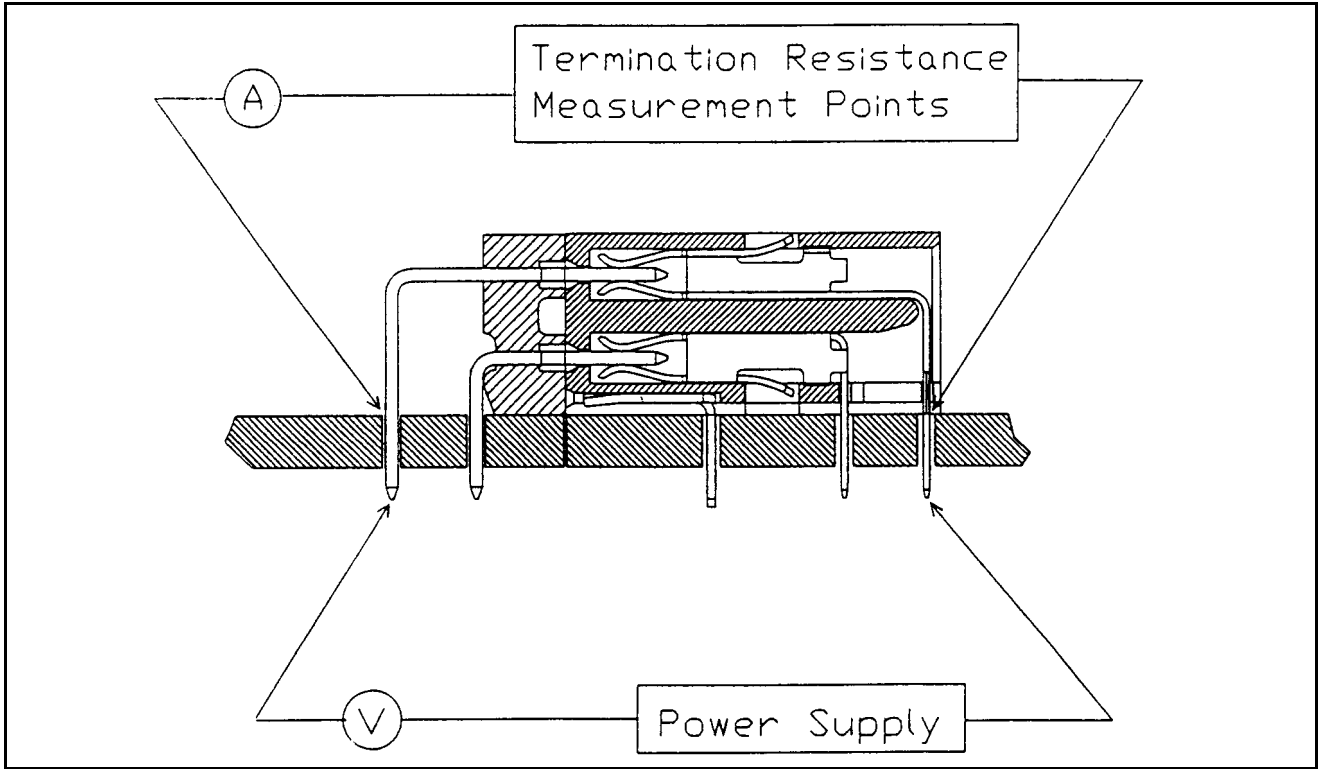

Figure 3
Termination Resistance Measurement Points

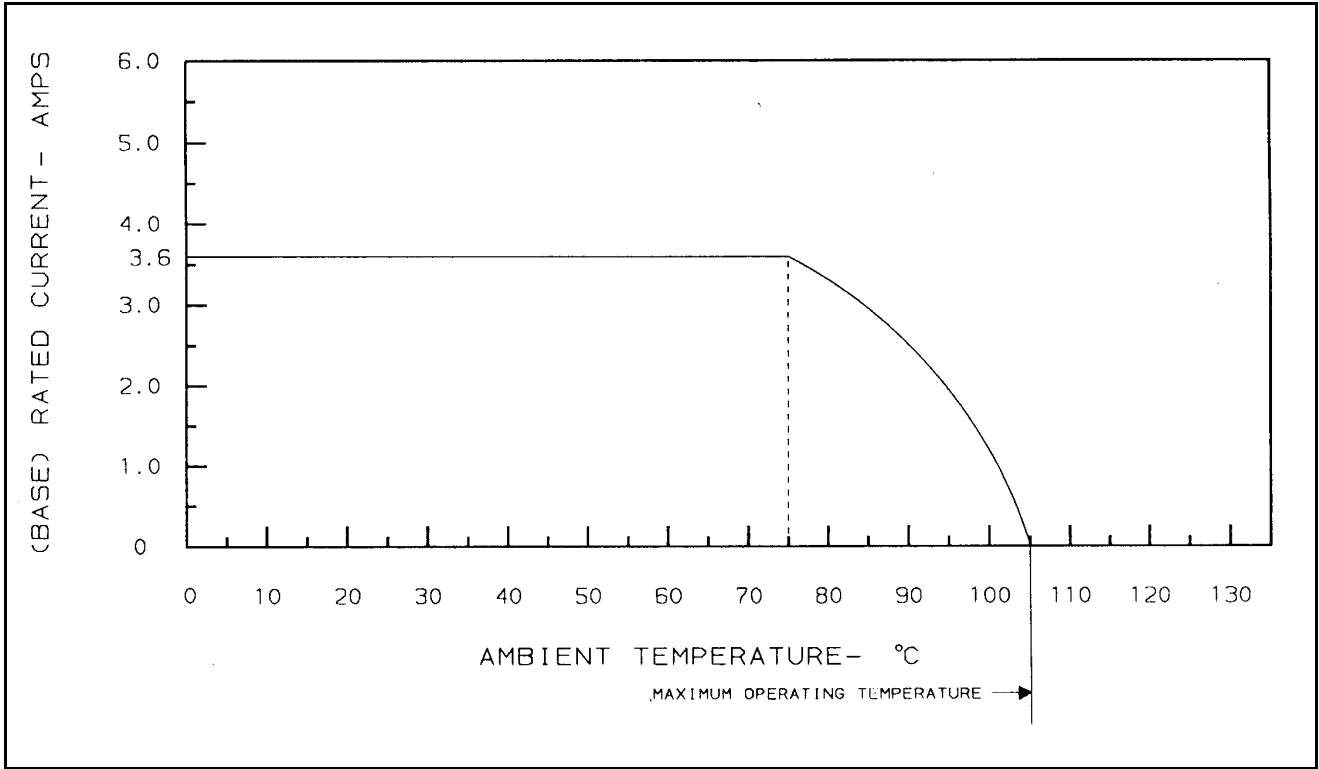

Figure 4A
Current Carrying Capability

Loading Density	F-Factor
Single Contact	1.00
50% Loaded (by rows)	0.431
100% Loaded	0.300

NOTE

To determine acceptable current carrying capacity for percentage connector loading, use Multiplication Factor (F) from above chart and multiply it times Base rated Current for a single circuit at maximum ambient operating temperature as shown in Figure 4A.

Figure 4B
Current Rating

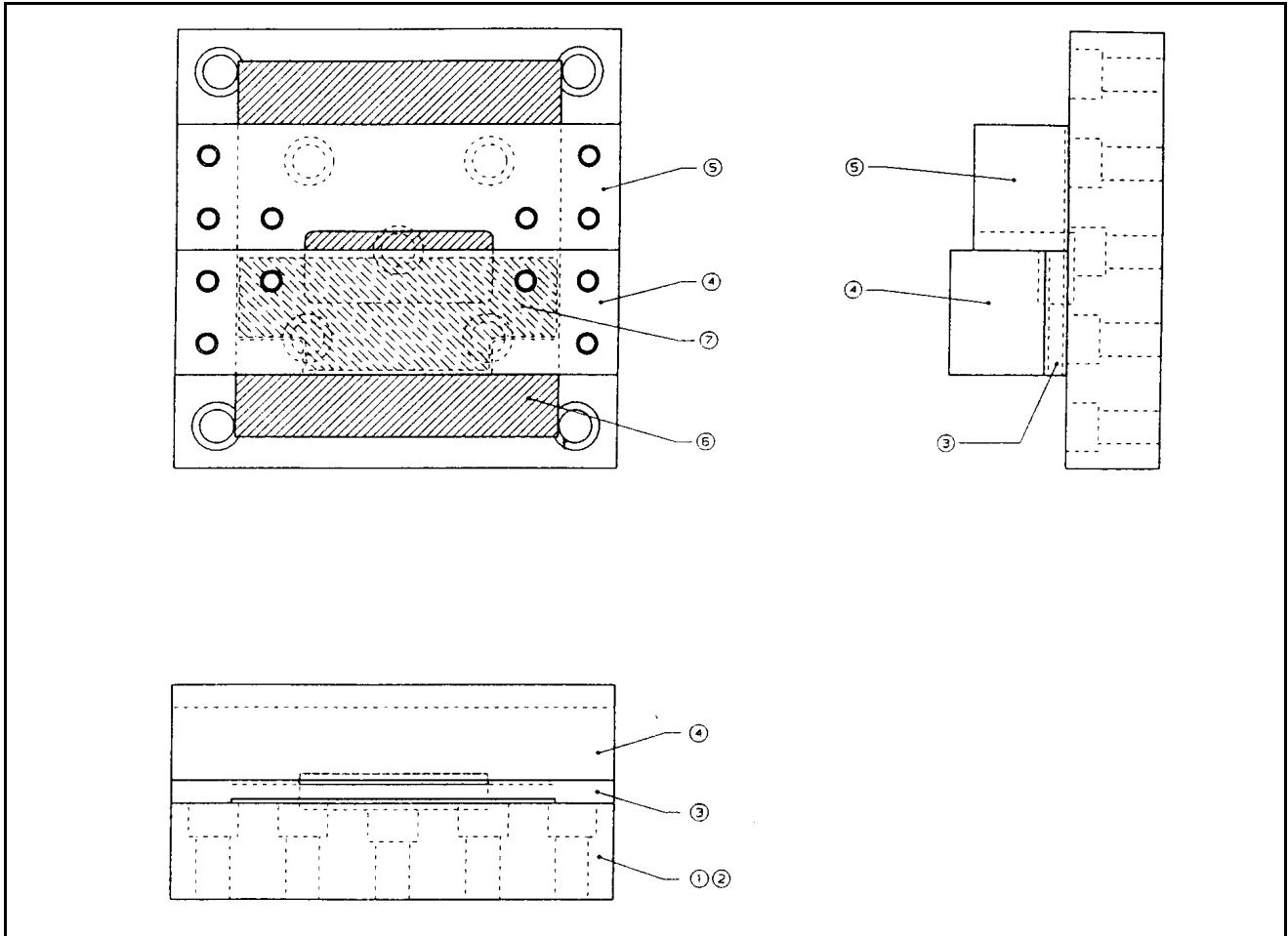

Note: See AMP Drawing 30-468787

Figure 5
Vibration & Physical Shock Mounting Fixture