

DETAIL Z
 POST DETAIL TYP
 2 POST MINIMUM

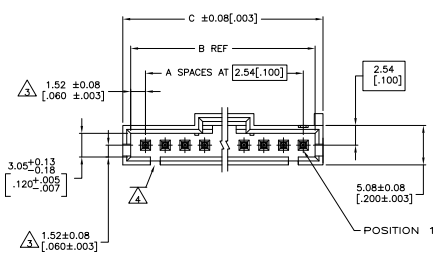

- △ FINISH: .00038[.000015] GOLD IN THE CONTACT AREA, .00254[.000100] MATTE TIN-LEAD ON REMAINDER OF CONTACT, ALL OVER .00127[.000050] NICKEL.
- △ POINT OF MEASUREMENT FOR PLATING THICKNESS.
- △ THE NOTED DIMENSIONS APPLY FROM THE BASIC DIMENSION CENTER LINE (NOT THE POST CENTER LINE) TO THE SURFACE INDICATED.
- △ ONE POLARIZATION SLOT FOR 2 AND 3 POSITION ASSEMBLIES ONLY.
- △ SELECT POST TAILS FORMED TO PROVIDE CONNECTOR HOLD DOWN UNTIL SOLDERED, CONFIGURATION ACCEPTS 0.69[.027]-2.03[.080] THICK PRINTED CIRCUIT BOARD. (SEE DETAIL Z).
- 6. PARTS ARE PACKAGED IN GANG OF TUBES.
- △ DIMENSIONS NOTED ARE FOR SOLDER STENCIL LAYOUT FOR USE WITH 1.58±0.20[.062±.008] THICK PRINTED CIRCUIT BOARDS.
- △ MATERIAL- HOUSING: HIGH TEMP THERMOPLASTIC, COLOR-BLACK. POSTS: BRASS.
- △ FINISH: .00038[.000015] GOLD IN THE CONTACT AREA, .00254[.000100] MATTE TIN ON REMAINDER OF CONTACT, ALL OVER .00127[.000050] NICKEL.

△	33.02 [1.300]	30.99 [1.220]	11	12	6-104809-1
△	30.48 [1.200]	28.45 [1.120]	10	11	6-104809-0
△	27.94 [1.100]	25.91 [1.020]	9	10	5-104809-9
△	25.40 [1.000]	23.37 [.920]	8	9	5-104809-8
△	22.86 [.900]	20.83 [.820]	7	8	5-104809-7
△	20.32 [.800]	18.29 [.720]	6	7	5-104809-6
△	17.78 [.700]	15.75 [.620]	5	6	5-104809-5
△	15.24 [.600]	13.21 [.520]	4	5	5-104809-4
△	12.70 [.500]	10.67 [.420]	3	4	5-104809-3
△	10.16 [.400]	8.13 [.320]	2	3	5-104809-2
△	7.62 [.300]	5.59 [.220]	1	2	5-104809-1
△	33.02 [1.300]	30.99 [1.220]	11	12	1-104809-1
△	30.48 [1.200]	28.45 [1.120]	10	11	1-104809-0
△	27.94 [1.100]	25.91 [1.020]	9	10	104809-9
△	25.40 [1.000]	23.37 [.920]	8	9	104809-8
△	22.86 [.900]	20.83 [.820]	7	8	104809-7
△	20.32 [.800]	18.29 [.720]	6	7	104809-6
△	17.78 [.700]	15.75 [.620]	5	6	104809-5
△	15.24 [.600]	13.21 [.520]	4	5	104809-4
△	12.70 [.500]	10.67 [.420]	3	4	104809-3
△	10.16 [.400]	8.13 [.320]	2	3	104809-2
△	7.62 [.300]	5.59 [.220]	1	2	104809-1
PLATING	C	B	A	NO. OF POSN	PART NO.

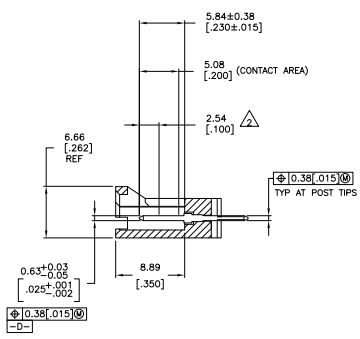
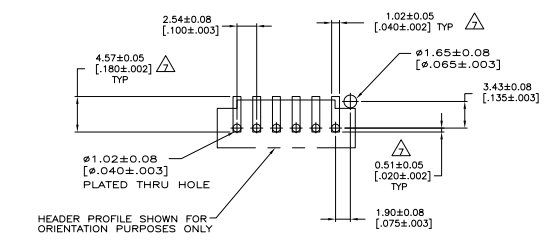

RECOMMENDED PC BOARD MOUNTING DIMENSIONS
 RECOMMENDED STENCIL THICKNESS = 0.25[.010]

THIS DRAWING IS A CONTROLLED DOCUMENT.		REV	DATE	DESCRIPTION	BY	CHK	APP
DIMENSIONS (mm INCHES)		ASSEMBLY	DATE	DATE	DATE	DATE	DATE
TOLERANCES UNLESS OTHERWISE SPECIFIED:		FRACTIONAL	DECIMAL	ANGLES	POSITION	FORM	FINISH
FRACTIONAL		DECIMAL	ANGLES	POSITION	FORM	FINISH	
SEE NOTE #		SEE TABLE					
CUSTOMER DRAWING		DATE	REV	DATE	REV	DATE	REV

TE Connectivity
 PLDZ HDR ASSY, AMPA00U MTE, VERTICAL
 SINGLE ROW, 2.54[.100] CL, 0.64[.025] SQ POSTS,
 WITH LATCHING & HOLD DOWN

SIZE: 100779 (G=104809)
 SHEET 1 OF 1