

FEATURES

Analog input/output

- 9-channel, 12-bit, 1 MSPS ADC
- 2 differential pairs with input PGA
- 7 general-purpose inputs (differential or single-ended)
- Fully differential and single-ended modes
- 0 V to V_{REF} analog input range
- 5 low noise current digital-to-analog converters (IDACs)
- 250 mA, 200 mA, 80 mA, 45 mA, 20 mA
- 4 × 12-bit voltage output DACs
- On-chip voltage reference
- On-chip temperature sensor

Microcontroller

- ARM7TDMI core, 16-bit/32-bit RISC architecture
- JTAG port supports code download and debug

Clocking options

- Trimmed on-chip oscillator ($\pm 3\%$)
- External watch crystal
- External clock source up to 41.78 MHz
- 41.78 MHz PLL with programmable divider

Memory

- 126 kB flash/EE memory, 8 kB SRAM
- In-circuit download, JTAG-based debug

Software-triggered in-circuit reprogrammability

On-chip peripherals

- UART, 2 × I²C and SPI serial I/O
- 32-pin GPIO port
- 4 × general-purpose timers
- Wake-up and watchdog timers (WDT)
- Power supply monitor
- Vectored interrupt controller for FIQ and IRQ
- 8 priority levels for each interrupt type
- Interrupt on edge or level external pin inputs

Power

- Specified for 3 V operation
- Active mode: 11 mA at 5 MHz, 40 mA at 41.78 MHz

Packages and temperature range

- 7 mm × 7 mm 108-ball CSP_BGA
- Fully specified for -10°C to $+95^{\circ}\text{C}$ operation

Tools

- Low cost QuickStart development system
- Full third party support

APPLICATIONS

- Optical modules—tunable laser

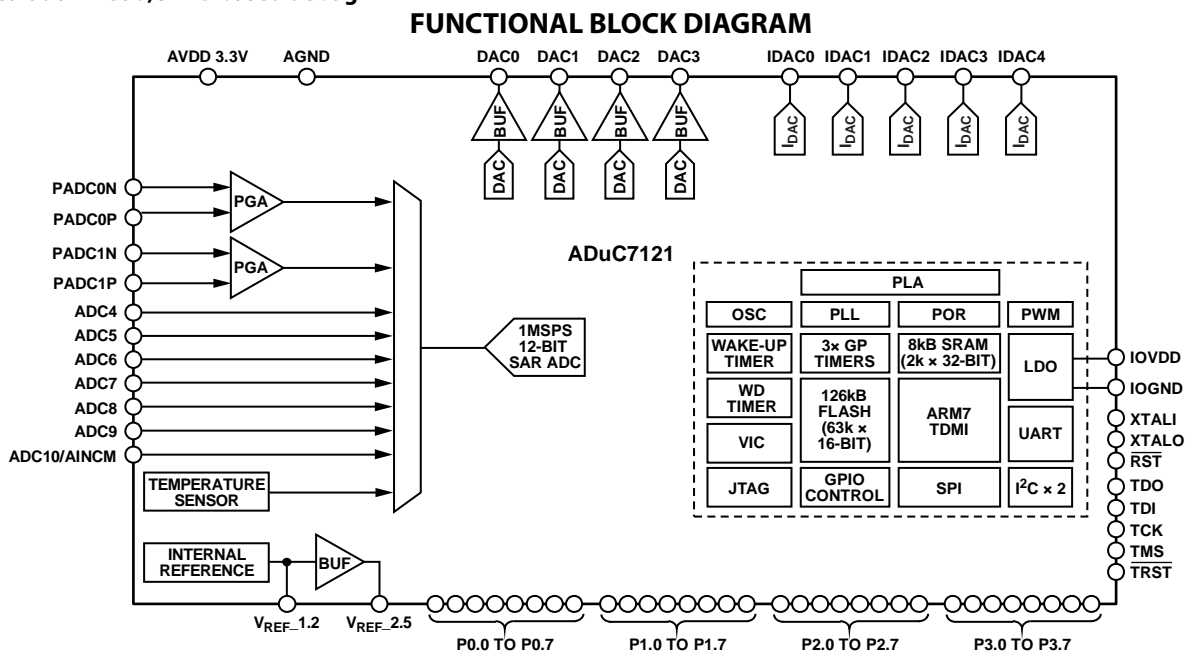

Figure 1.

09492-001

Rev. 0

Information furnished by Analog Devices is believed to be accurate and reliable. However, no responsibility is assumed by Analog Devices for its use, nor for any infringements of patents or other rights of third parties that may result from its use. Specifications subject to change without notice. No license is granted by implication or otherwise under any patent or patent rights of Analog Devices. Trademarks and registered trademarks are the property of their respective owners.

One Technology Way, P.O. Box 9106, Norwood, MA 02062-9106, U.S.A.
Tel: 781.329.4700 www.analog.com
Fax: 781.461.3113 ©2011 Analog Devices, Inc. All rights reserved.

TABLE OF CONTENTS

Features	1	Other Analog Peripherals.....	41
Applications.....	1	Digital-to-Analog Converters.....	41
Functional Block Diagram	1	LDO (Low Dropout Regulator).....	43
Revision History	3	Current Output DACs (IDAC).....	43
General Description	4	IDAC MMRs.....	45
Specifications.....	5	Oscillator and PLL—Power Control.....	46
Timing Specifications	10	Digital Peripherals.....	50
Absolute Maximum Ratings.....	15	PWM General Overview.....	50
ESD Caution.....	15	PWM Convert Start Control	52
Pin Configuration and Function Descriptions.....	16	General-Purpose Input/Output.....	53
Terminology	20	UART Serial Interface.....	58
ADC Specifications	20	Baud Rate Generation.....	58
DAC Specifications.....	20	UART Register Definition.....	58
Overview of the ARM7TDMI Core.....	21	I ² C Peripherals	63
Thumb Mode (T).....	21	Serial Clock Generation	63
Long Multiply (M).....	21	I ² C Bus Addresses.....	63
EmbeddedICE (I)	21	I ² C Registers	64
Exceptions	21	I ² C Common Registers.....	72
ARM Registers	22	Serial Peripheral Interface.....	73
Interrupt Latency.....	22	SPI MISO (Master In, Slave Out) Pin.....	73
Memory Organization	23	SPI MOSI (Master Out, Slave In) Pin.....	73
Memory Access.....	23	SPICLK (Serial Clock I/O) Pin.....	73
Flash/EE Memory.....	23	SPI Chip Select Input Pin.....	73
SRAM.....	23	Configuring External Pins for SPI Functionality.....	73
Memory Mapped Registers	23	SPI Registers.....	73
Complete MMR Listing.....	24	Programmable Logic Array (PLA).....	76
ADC Circuit Overview	27	PLA MMRs Interface.....	77
ADC Transfer Function.....	27	Interrupt System	80
Temperature Sensor	29	Normal Interrupt Request (IRQ)	80
Converter Operation.....	31	Fast Interrupt Request (FIQ)	81
Driving the Analog Inputs	33	External Interrupts (IRQ0 to IRQ3).....	85
Band Gap Reference.....	33	Timers	87
Power Supply Monitor	34	Timer0—Lifetime Timer	87
Nonvolatile Flash/EE Memory	35	Timer1—General-Purpose Timer	88
Flash/EE Memory Overview.....	35	Timer2—Wake-Up Timer	90
Flash/EE Memory.....	35	Timer3—Watchdog Timer.....	91
Flash/EE Memory Security	35	Timer4—General-Purpose Timer	93
Flash/EE Control Interface.....	36	Outline Dimensions	95
Execution Time from SRAM and FLASH/EE.....	39	Ordering Guide	95
Reset and Remap	39		

REVISION HISTORY

1/11—Revision 0: Initial Version

GENERAL DESCRIPTION

The ADuC7121 is a fully integrated, 1 MSPS, 12-bit data acquisition system incorporating a high performance multichannel ADC, 16-bit/32-bit MCU, and Flash[®]/EE memory on a single chip.

The ADC consists of up to seven single-ended inputs and two extra differential input pairs. The two differential pair inputs can be routed through a programmable gain amplifier (PGA). The ADC can operate in single-ended or differential input mode. The ADC input voltage is 0 V to V_{REF} . A low drift band gap reference, temperature sensor, and voltage comparator complete the ADC peripheral set.

The ADuC7121 provides five current output digital-to-analog converters (DACs). The current sources (five current DACs) feature low noise and low drift high-side current output at 11-bit resolution. The five IDACs are as follows: IDAC0 with 250 mA full-scale (FS) output, IDAC1 with 200 mA FS output, IDAC2 with 80 mA FS output, IDAC3 with 45 mA FS output, and IDAC4 with 20 mA FS output.

The ADuC7121 also contains four voltage output digital-to-analog converters (DACs). The DAC output range is programmable to one of three voltage ranges.

The devices operate from an on-chip oscillator and a PLL generating an internal high frequency clock of 41.78 MHz (UCLK). This clock is routed through a programmable clock divider from which the MCU core clock operating frequency is generated. The microcontroller core is an ARM7TDMI[®], 16-bit/32-bit RISC machine, which offers up to 41 MIPS peak performance. Eight kB of SRAM and 126 kB of nonvolatile Flash/EE memory are provided on chip. The ARM7TDMI core views all memory and registers as a single linear array.

On-chip factory firmware supports in-circuit serial download via the I²C serial interface port; nonintrusive emulation is also supported via the JTAG interface. These features are incorporated into a low cost QuickStart[™] development system supporting this MicroConverter[®] family.

The device operates from 3.0 V to 3.6 V, and it is specified over an industrial temperature range of -10°C to $+95^{\circ}\text{C}$. The IDACs are powered from a separate 2 V input power supply. When operating at 41.78 MHz, the power dissipation is typically 120 mW. The ADuC7121 is available in a 108-ball chip scale package ball grid array [CSP_BGA].

SPECIFICATIONS

$V_{DD} = IOV_{DD} = 3.0\text{ V}$ to 3.6 V , $PV_{DD} = 2.0\text{ V} \pm 5\%$, $V_{REF} = 2.5\text{ V}$ internal reference, $f_{CORE} = 41.78\text{ MHz}$, $T_A = -10^\circ\text{C}$ to $+95^\circ\text{C}$, unless otherwise noted.

Table 1.

Parameter	Min	Typ	Max	Unit	Test Conditions/Comments
ADC CHANNEL SPECIFICATIONS					
ADC Power-Up Time		5		μs	Eight acquisition clocks and $f_{ADC}/2$ 2.5 V internal reference, not production tested for PADC0 and PADC1 channels 2.5 V internal reference, guaranteed monotonic ADC input is a dc voltage
DC Accuracy ^{1, 2}	12			Bits	
Resolution				LSB	
Integral Nonlinearity		± 0.6	± 2	LSB	
Differential Nonlinearity ^{3, 4}		± 0.5	$+1.4/-0.99$	LSB	
DC Code Distribution		1		LSB	
ENDPOINT ERRORS⁵					
Offset Error					Internally unbuffered channels
All Channels Except IDACx Channels		± 2	± 5	LSB	
IDACx Channels Only		1		% of full scale	
Offset Error Match		± 1		LSB	
Gain Error		± 2	± 5	LSB	
Gain Error Match		± 1		LSB	
DYNAMIC PERFORMANCE					
Signal-to-Noise Ratio (SNR)		69		dB	$f_{IN} = 10\text{ kHz}$ sine wave, $f_{SAMPLE} = 1\text{ MSPS}$, internally unbuffered channels Includes distortion and noise components
Total Harmonic Distortion (THD)		-78		dB	
Peak Harmonic or Spurious Noise		-75		dB	
Channel-to-Channel Crosstalk		-80		dB	
ANALOG INPUT					
Input Voltage Ranges					See Table 38 Buffer bypassed Buffer enabled
Differential Mode			$V_{CM}^6 \pm V_{REF}/2$	V	
Single-Ended Mode			0 to V_{REF}	V	
Leakage Current	0.15	± 0.2	± 1	μA	
Input Capacitance		20		pF	During ADC acquisition buffer bypassed During ADC acquisition buffer enabled
		20		pF	
PADC0x INPUT					
Full-Scale Input Range	20		1000	μA	28.3 k Ω resistor, PGA gain = 3, acquisition time = 3.2 μs , pseudo differential mode
Input Leakage at PADC0x ⁴		0.15	2	nA	
Resolution	11			Bits	0.1% accuracy, 5 ppm external resistor for current to voltage
Gain Error ⁴			1	%	
Gain Drift ⁴			50	ppm/ $^\circ\text{C}$	PGA offset not included
Offset ⁴		3	6	nA	
Offset Drift ⁴		30	60	pA/ $^\circ\text{C}$	
PADC0x Compliant Range	0.1		$AV_{DD} - 1.2$	V	

ADuC7121

Parameter	Min	Typ	Max	Unit	Test Conditions/Comments
PADC1 INPUT					
Full-Scale Input Range	10.6		700	μA	53.5 kΩ resistor, PGA gain = 3
Input Leakage at PADC1x ⁴		0.15	2	nA	
Resolution	11			Bits	0.1% accuracy, 5 ppm external resistor for current to voltage
Gain Error ⁴			1	%	
Gain Drift ⁴			50	ppm/°C	PGA offset not included
Offset ⁴		3	6	nA	
Offset Drift ⁴		30	60	pA/°C	
PADC1x-Compliant Range	0.1		AV _{DD} - 1.2	V	
ON-CHIP VOLTAGE REFERENCE					
Output Voltage		2.5		V	0.47 μF from V _{REF} to AGND
Accuracy ⁷			±5	mV	T _A = 25°C
Reference Temperature Coefficient ⁴		10	30	ppm/°C	
Power Supply Rejection Ratio		61		dB	
Output Impedance		10		Ω	T _A = 25°C
Internal V _{REF} Power-On Time		1		ms	
EXTERNAL REFERENCE INPUT					
Input Voltage Range	1.2		AV _{DD}	V	
IDAC CHANNEL SPECIFICATIONS					
Voltage Compliance Range	0.4		1.6	V	Output voltage compliance
Voltage Compliance Range, IDAC0	-0.2		+1.6 ⁸	V	For IDAC0 channel only, linearity not guaranteed below 0 V
REFERENCE CURRENT GENERATOR					
Reference Current		0.38		mA	Using internal reference, 0.1% 5 ppm 3.16 kΩ external resistor
Temperature Coefficient		25		ppm/°C	Using internal reference
Short-Circuit Detection		1		mA	
Overheat Shutdown		135		°C	Junction temperature
RESOLUTION					
		11		Bits	Guaranteed monotonic
FULL-SCALE OUTPUT					
IDAC4		20		mA	11-bit mode RMS value, bandwidth 20 Hz to 10 MHz V _{OUT} = 1.6 V Internal V _{REF} , 5 ppm external resistor Pull-down switch off, V _{OUT} = 0 V Output range 0.4 V to 1.6 V Output range -0.2 V to +1.6 V To 0.1%
IDAC3		45		mA	
IDAC2		80		mA	
IDAC1		200		mA	
IDAC0		250		mA	
Integral Nonlinearity		±2		LSB	
Noise Current		20		μA	
Full-Scale Error		±3		%	
Full-Scale Error Drift		50		ppm/°C	
Zero-Scale Error					
IDAC4 Channel			±30	μA	
IDAC3 Channel			+42/-70	μA	
IDAC2 Channel			+70/-110	μA	
IDAC1 Channel			±240	μA	
IDAC0 Channel			±250	μA	
IDAC0 Channel			+580/-430	μA	
Settling Time		1		ms	
Signal Bandwidth		20		kHz	

Parameter	Min	Typ	Max	Unit	Test Conditions/Comments
LINE REGULATION					Measured with full-scale current load on current DACs
IDAC4		10		$\mu\text{A}/\text{V}$	
IDAC3		22.5		$\mu\text{A}/\text{V}$	
IDAC2		40		$\mu\text{A}/\text{V}$	
IDAC1		100		$\mu\text{A}/\text{V}$	
IDAC0		750		$\mu\text{A}/\text{V}$	
LOAD REGULATION					Measured with full-scale current load on current DACs
IDAC4		10		$\mu\text{A}/\text{V}$	
IDAC3		22.5		$\mu\text{A}/\text{V}$	
IDAC2		40		$\mu\text{A}/\text{V}$	
IDAC1		100		$\mu\text{A}/\text{V}$	
IDAC0		750		$\mu\text{A}/\text{V}$	
ACPSRR ⁴	0.75%			% of full-scale/V	10 kHz, percentage of each current DAC full-scale current per volt
	6%			% of full-scale/V	2.25 MHz, percentage of each current DAC full-scale current per volt
PULL-DOWN NMOS Speed ⁴		100	10	mV μs	Drain 40 mA Triggered by PLA, draw the pin voltage to 10% of its original value
Voltage DAC (VDAC) CHANNEL					$R_L = 5 \text{ k}\Omega$, $C_L = 100 \text{ pF}$ Buffered
DC Accuracy ⁹					
Resolution		12		Bits	
Relative Accuracy		± 2		LSB	
Differential Nonlinearity		± 0.2	± 1	LSB	Guaranteed monotonic
Calculated Offset Error		± 2		mV	2.5 V internal reference
Actual Offset Error		9		mV	Measured at Code 0
Gain Error ¹⁰		± 0.15	± 0.8	%	
Gain Error Mismatch		0.1		%	% of full scale on DAC0
Settling Time		10		μs	
PSRR ⁴					Buffered
DC	-59	-61		dB	
1 kHz	-57			dB	
10 kHz	-47			dB	
100 kHz	-19			dB	
DRIFT					
Offset Drift ⁴			10	$\mu\text{V}/^\circ\text{C}$	
Gain Error Drift ⁴			10	$\mu\text{V}/^\circ\text{C}$	
SHORT-CIRCUIT CURRENT		20		mA	
ANALOG OUTPUTS					
Output Range	0.1		$V_{\text{REF}}/AV_{\text{DD}} - 0.1$		Buffer on
DAC AC CHARACTERISTICS					
Slew Rate		2.49		V/ μs	
Voltage Output Settling Time		10		μs	
Digital-to-Analog Glitch Energy		± 20		nV-sec	1 LSB change at major carry (where maximum number of bits simultaneously change in the DACxDAT register)

ADuC7121

Parameter	Min	Typ	Max	Unit	Test Conditions/Comments
TEMPERATURE SENSOR ¹¹ Voltage Output at 25°C Voltage Temperature Coefficient Accuracy		707 -1.25 ±3		mV mV/°C °C	After user calibration MCU in power-down or standby mode before measurement
POWER SUPPLY MONITOR (PSM) IOV _{DD} Trip Point Selection Power Supply Trip Point Accuracy		2.79 3.07 ±2.5		V V %	Two selectable trip points Of the selected nominal trip point voltage
POWER-ON RESET		2.36		V	
WATCHDOG TIMER (WDT) Timeout Period	0		512	sec	
FLASH/EE MEMORY Endurance ¹² Data Retention ¹³	10,000 20			Cycles Years	T _J = 85°C
DIGITAL INPUTS Logic 1 Input Current Logic 0 Input Current Input Capacitance		±0.2 -40 10	±1 -60	µA µA pF	All digital inputs excluding XCLKI and XCLKO V _{IH} = V _{DD} V _{IL} = 0 V; except TDI
LOGIC INPUTS ⁴ V _{INL} , Input Low Voltage ⁴ V _{INH} , Input High Voltage ⁴	2.0		0.8	V V	All logic inputs excluding XCLKI
LOGIC OUTPUTS V _{OH} , Output High Voltage V _{OL} , Output Low Voltage ¹⁴	2.4		0.4	V V	All digital outputs excluding XCLKO I _{SOURCE} = 1.6 mA I _{SINK} = 1.6 mA
CRYSTAL INPUTS (XCLKI AND XCLKO) Logic Inputs, XCLKI Only V _{INL} , Input Low Voltage V _{INH} , Input High Voltage XCLKI Input Capacitance XCLKO Output Capacitance		1.1 1.7 20 20		V V pF pF	
INTERNAL OSCILLATOR		32.768	±3	kHz %	
MCU CLOCK RATE From 32 kHz Internal Oscillator From 32 kHz External Crystal Using an External Clock	0.05	326 41.78	41.78	kHz MHz MHz	Clock divider (CD) = 7 CD = 0 T _A = 95°C
START-UP TIME At Power-On From Pause/Nap Mode From Sleep Mode From Stop Mode		70 24 3.06 1.58 1.7		ms ns µs ms ms	Core clock (HCLK) = 41.78 MHz CD = 0 CD = 7
PROGRAMMABLE LOGIC ARRAY (PLA) Pin Propagation Delay Element Propagation Delay		12 2.5		ns ns	From input pin to output pin
POWER REQUIREMENTS ^{15, 16} Power Supply Voltage Range AV _{DD} to AGND and IOV _{DD} to IOGND Analog Power Supply Currents AV _{DD} Current	3.0		3.6	V µA	ADC in idle mode

Parameter	Min	Typ	Max	Unit	Test Conditions/Comments
Digital Power Supply Current					
IOV _{DD} Current in Normal Mode		7		mA	Code executing from Flash/EE CD = 7
		11		mA	CD = 3
		30	40	mA	CD = 0 (41.78 MHz clock)
IOV _{DD} Current in Pause Mode ⁴		25		mA	CD = 0 (41.78 MHz clock)
IOV _{DD} Current in Sleep Mode ⁴		100		μA	T _A = 25°C
Additional Power Supply Currents					
ADC		2.7		mA	@1 MSPS
IDAC		21		mA	All current DACs (IDACs) on
DAC		250		μA	per VDAC
ESD TESTS					2.5 V reference, T _A = 25°C
HBM Passed Up to			4	kV	
FICDM Passed Up to			0.5	kV	

¹ All ADC channel specifications are guaranteed during normal MicroConverter core operation.

² Apply to all ADC input channels.

³ Measured using the factory set default values in the ADC offset register (ADCOF) and gain coefficient register (ADCGN).

⁴ Not production tested but supported by design and/or characterization data on production release.

⁵ Measured using the factory set default values in ADCOF and ADCGN with an external AD845 op amp as an input buffer stage as shown in Figure 23. Based on external ADC system components, the user may need to execute a system calibration to remove external endpoint errors and achieve these specifications (see the ADC section).

⁶ The input signal can be centered on any dc common-mode voltage (V_{CM}) provided that this value is within the ADC voltage input range specified.

⁷ V_{REF} calibration and trimming are performed under the following conditions: the core is operating in normal mode CD = 0, the ADC is on, the current DACs are on, and all VDACS are on. V_{REF} accuracy may vary under other operating conditions.

⁸ The PVDD_IDAC0 pad voltage must be at least 300 mV greater than the IDAC0 pad voltage. These voltages are measured via the PVDD0 and IDAC0 channels of the ADC. This allows the IDAC0 pin to be pulled up to 1.7 V provided that this 300 mV differential voltage is maintained between the pads. This may require the PVDD_IDAC0 being supplied with a voltage greater than 2.0 V. The 2.1 V maximum PVDD_IDACx rating must not be exceeded.

⁹ DAC linearity is calculated using a reduced code range of 100 to 3995.

¹⁰ DAC gain error is calculated using a reduced code range of 100 to internal 2.5 V V_{REF} .

¹¹ Die temperature.

¹² Endurance is qualified as per JEDEC Standard 22 Method A117 and measured at -40°C, +25°C, +85°C, and +125°C.

¹³ Retention lifetime equivalent at junction temperature (T_J) = 85°C as per JEDEC Standard 22 Method A117. Retention lifetime derates with junction temperature.

¹⁴ Test carried out with a maximum of eight I/Os set to a low output level.

¹⁵ Power supply current consumption is measured in normal, pause, and sleep modes under the following conditions: normal mode using a 3.6 V supply, pause mode using a 3.6 V supply, and sleep mode using 3.6 V supply.

¹⁶ IOV_{DD} power supply current increases typically by 2 mA during a Flash/EE erase cycle.

TIMING SPECIFICATIONS

Table 2. I²C Timing in Fast Mode (400 kHz)

Parameter	Description	Slave		Master	Unit
		Min	Max	Typ	
t _L	SCL low pulse width	200		1360	ns
t _H	SCL high pulse width	100		1140	ns
t _{SHD}	Start condition hold time	300		251,350	ns
t _{DSU}	Data setup time	100		740	ns
t _{DHD}	Data hold time	0		400	ns
t _{RSU}	Setup time for repeated start	100		12.51350	ns
t _{PSU}	Stop condition setup time	100		400	ns
t _{BUF}	Bus-free time between a stop condition and a start condition	1.3			μs
t _R	Rise time for both SCL and SDA		300	200	ns
t _F	Fall time for both SCL and SDA		300		ns
t _{SUP}	Pulse width of spike suppressed		50		ns

Table 3. I²C Timing in Standard Mode (100 kHz)

Parameter	Description	Slave		Unit
		Min	Max	
t _L	SCLx low pulse width	4.7		μs
t _H	SCLx high pulse width	4.0		ns
t _{SHD}	Start condition hold time	4.0		μs
t _{DSU}	Data setup time	250		ns
t _{DHD}	Data hold time	0	3.45	μs
t _{RSU}	Setup time for repeated start	4.7		μs
t _{PSU}	Stop condition setup time	4.0		μs
t _{BUF}	Bus-free time between a stop condition and a start condition	4.7		μs
t _R	Rise time for both SCLx and SDAx		1	μs
t _F	Fall time for both SCLx and SDAx		300	ns

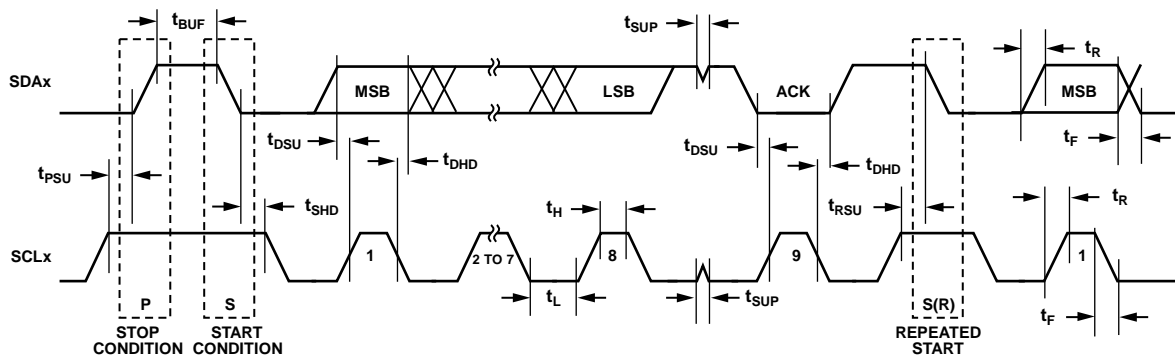

Figure 2. I²C-Compatible Interface Timing

08492-002

Table 4 SPI Master Mode Timing (Phase Mode = 1)

Parameter	Description	Min	Typ	Max	Unit
t_{SL}	SPICLK low pulse width		$(SPIDIV + 1) \times t_{uCLK}$		ns
t_{SH}	SPICLK high pulse width		$(SPIDIV + 1) \times t_{uCLK}$		ns
t_{DAV}	Data output valid after SPICLK edge			25	ns
t_{DSU}	Data input setup time before SPICLK edge ¹	$1 \times t_{uCLK}$			ns
t_{DHD}	Data input hold time after SPICLK edge	$2 \times t_{uCLK}$			ns
t_{DF}	Data output fall time		5	12.5	ns
t_{DR}	Data output rise time		5	12.5	ns
t_{SR}	SPICLK rise time		5	12.5	ns
t_{SF}	SPICLK fall time		5	12.5	ns

¹ $t_{uCLK} = 23.9$ ns. It corresponds to the 41.78 MHz internal clock from the PLL before the clock divider.

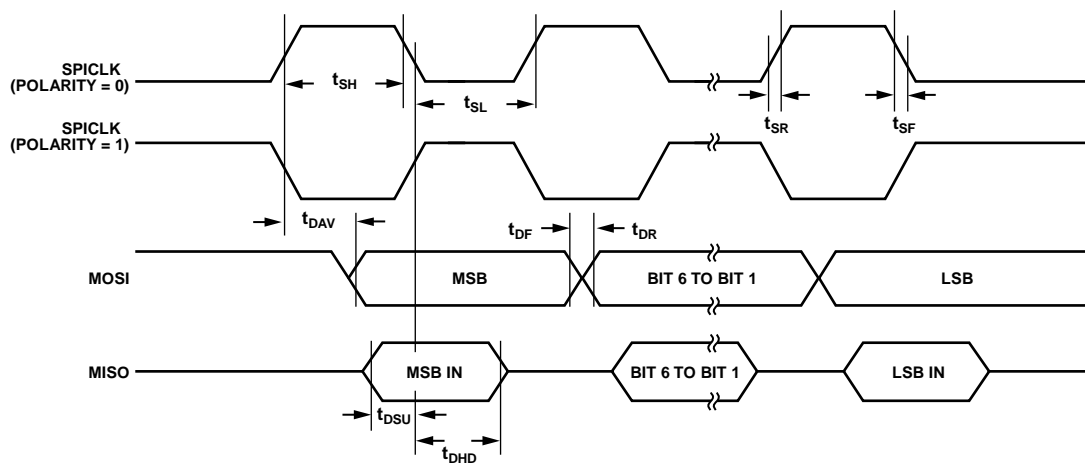

Figure 3. SPI Master Mode Timing (Phase Mode = 1)

Table 5. SPI Master Mode Timing (Phase Mode = 0)

Parameter	Description	Min	Typ	Max	Unit
t_{SL}	SPICLK low pulse width		$(SPIDIV + 1) \times t_{UCLK}$		ns
t_{SH}	SPICLK high pulse width		$(SPIDIV + 1) \times t_{UCLK}$		ns
t_{DAV}	Data output valid after SPICLK edge			25	ns
t_{DOSU}	Data output setup before SPICLK edge			75	ns
t_{DSU}	Data input setup time before SPICLK edge ¹	$1 \times t_{UCLK}$			ns
t_{DHD}	Data input hold time after SPICLK edge	$2 \times t_{UCLK}$			ns
t_{DF}	Data output fall time		5	12.5	ns
t_{DR}	Data output rise time		5	12.5	ns
t_{SR}	SPICLK rise time		5	12.5	ns
t_{SF}	SPICLK fall time		5	12.5	ns

¹ $t_{UCLK} = 23.9$ ns. It corresponds to the 41.78 MHz internal clock from the PLL before the clock divider.

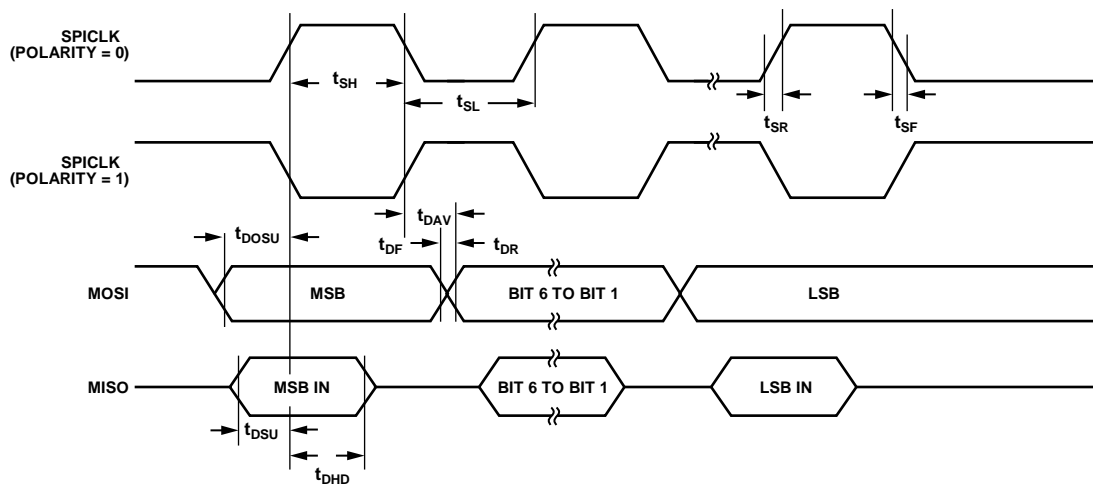

Figure 4. SPI Master Mode Timing (Phase Mode = 0)

08452-004

Table 6. SPI Slave Mode Timing (Phase Mode = 1)

Parameter	Description	Min	Typ	Max	Unit
$t_{\overline{CS}}$	\overline{CS} to the SPICLK edge ¹	200			ns
t_{SL}	SPICLK low pulse width ²		$(SPIDIV + 1) \times t_{UCLK}$		ns
t_{SH}	SPICLK high pulse width ²		$(SPIDIV + 1) \times t_{UCLK}$		ns
t_{DAV}	Data output valid after SPICLK edge			25	ns
t_{DSU}	Data input setup time before SPICLK edge	$1 \times t_{UCLK}$			ns
t_{DHD}	Data input hold time after SPICLK edge	$2 \times t_{UCLK}$			ns
t_{DF}	Data output fall time		5	12.5	ns
t_{DR}	Data output rise time		5	12.5	ns
t_{SR}	SPICLK rise time		5	12.5	ns
t_{SF}	SPICLK fall time		5	12.5	ns
t_{SFS}	\overline{CS} high after SPICLK edge	0			ns

¹ \overline{CS} is the \overline{CS} (SPI slave select input) function of the multifunction Pin F3.

² $t_{UCLK} = 23.9$ ns. It corresponds to the 41.78 MHz internal clock from the PLL before the clock divider.

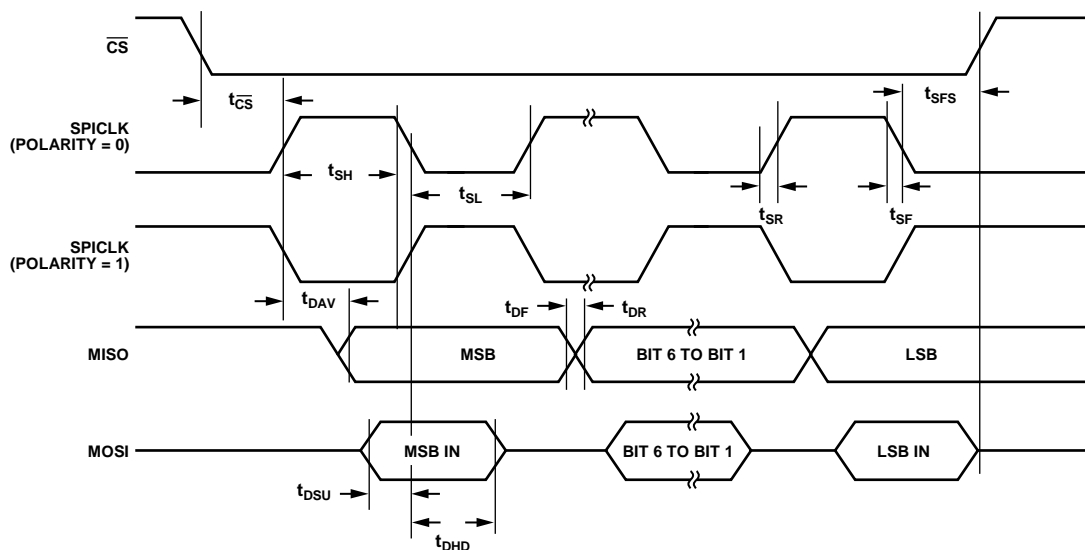

Figure 5. SPI Slave Mode Timing (Phase Mode = 1)

09492-005

Table 7. SPI Slave Mode Timing (Phase Mode = 0)

Parameter	Description	Min	Typ	Max	Unit
$t_{\overline{CS}}$	\overline{CS} to SPICLK edge ¹	200			ns
t_{SL}	SPICLK low pulse width ²		$(SPIDIV + 1) \times t_{UCLK}$		ns
t_{SH}	SPICLK high pulse width ²		$(SPIDIV + 1) \times t_{UCLK}$		ns
t_{DAV}	Data output valid after SPICLK edge			25	ns
t_{DSU}	Data input setup time before SPICLK edge ²	$1 \times t_{UCLK}$			ns
t_{DHD}	Data input hold time after SPICLK edge ²	$2 \times t_{UCLK}$			ns
t_{DF}	Data output fall time		5	12.5	ns
t_{DR}	Data output rise time		5	12.5	ns
t_{SR}	SPICLK rise time		5	12.5	ns
t_{SF}	SPICLK fall time		5	12.5	ns
t_{DOCS}	Data output valid after \overline{CS} edge			25	ns
t_{SFS}	\overline{CS} high after SPICLK edge	0			ns

¹ \overline{CS} is the \overline{CS} (SPI slave select input) function of the multifunction Pin F3.

² $t_{UCLK} = 23.9$ ns. It corresponds to the 41.78 MHz internal clock from the PLL before the clock divider.

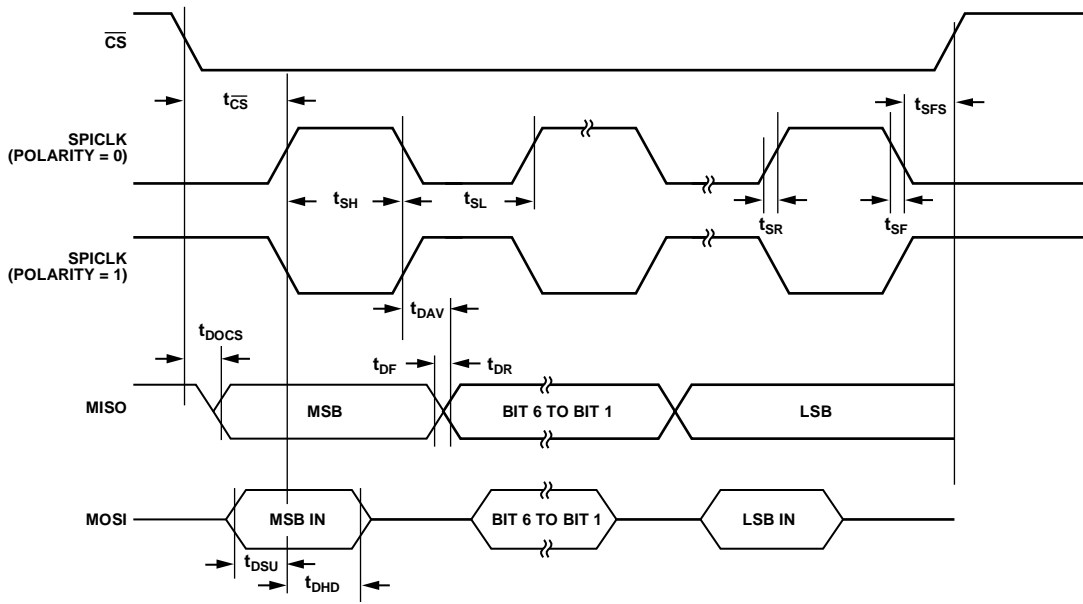

Figure 6. SPI Slave Mode Timing (Phase Mode = 0)

09482-006

ABSOLUTE MAXIMUM RATINGS

AGND = 0 V, $T_A = 25^\circ\text{C}$, unless otherwise noted.

Table 8.

Parameter	Rating
AV_{DD} to IOV_{DD}	-0.3 V to +0.3 V
AGND to DGND	-0.3 V to +0.3 V
IOV_{DD} to IOGND, AV_{DD} to AGND	-0.3 V to +6 V
Digital Input Voltage to IOGND	-0.3 V to +5.3 V
Digital Output Voltage to IOGND	-0.3 V to $IOV_{DD} + 0.3$ V
$V_{REF_2.5}$ and $V_{REF_1.2}$ to AGND	-0.3 V to $AV_{DD} + 0.3$ V
Analog Inputs to AGND	-0.3 V to $AV_{DD} + 0.3$ V
Analog Outputs to AGND	-0.3 V to $AV_{DD} + 0.3$ V
Operating Temperature Range, Industrial	-10°C to +95°C
Storage Temperature Range	-65°C to +150°C
Junction Temperature	150°C
θ_{JA} Thermal Impedance	
108-Ball CSP_BGA	40°C/W
Peak Solder Reflow Temperature	
SnPb Assemblies (10 sec to 30 sec)	240°C
RoHS-Compliant Assemblies (20 sec to 40 sec)	260°C

Stresses above those listed under Absolute Maximum Ratings may cause permanent damage to the device. This is a stress rating only; functional operation of the device at these or any other conditions above those indicated in the operational section of this specification is not implied. Exposure to absolute maximum rating conditions for extended periods may affect device reliability.

Only one absolute maximum rating can be applied at any one time.

ESD CAUTION



ESD (electrostatic discharge) sensitive device. Charged devices and circuit boards can discharge without detection. Although this product features patented or proprietary protection circuitry, damage may occur on devices subjected to high energy ESD. Therefore, proper ESD precautions should be taken to avoid performance degradation or loss of functionality.

PIN CONFIGURATION AND FUNCTION DESCRIPTIONS

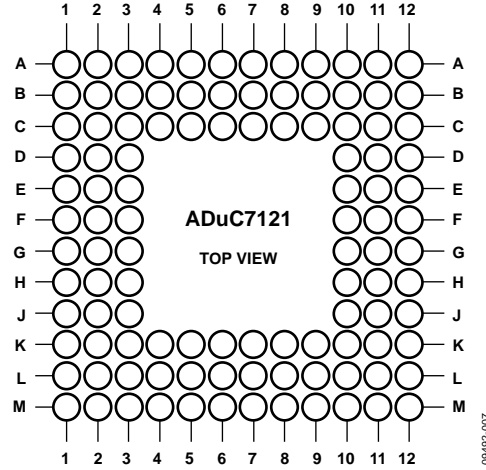

Figure 7. Pin Configuration

Table 9. Pin Function Descriptions

Pin No.	Mnemonic	Type ¹	Description
C12	RST	I	Reset Input (Active Low).
D11	P0.0/SCL0/PLAI[5]	I/O	General-Purpose Input and Output Port 0.0 (P0.0). I ² C Interface Serial Clock for I ² C0 (SCL0). Programmable Logic Array for Input Element 5 (PLAI[5]).
E11	P0.1/SDA0/PLAI[4]	I/O	General-Purpose Input and Output Port 0.1 (P0.1). I ² C Interface Serial Data for I ² C0 (SDA0). Programmable Logic Array for Input Element 4 (PLAI[4]).
C3	P0.2/SPICLK/ADC _{BUSY} /PLAO[13]	I/O	General-Purpose Input and Output Port 0.2 (P0.2). SPI Clock (SPICLK). Status of the ADC (ADC _{BUSY}). Programmable Logic Array for Output Element 13 (PLAO[13]).
D3	P0.3/MISO/PLAO[12]/SYNC	I/O	General-Purpose Input and Output Port 0.3 (P0.3). SPI Master In Slave Out (MISO). Programmable Logic Array for Output Element 12 (PLAO[12]). Synchronous Reset (SYNC). Input to reset synchronously the PWM counters using an external source.
E3	P0.4/MOSI/PLAI[11]/TRIP	I/O	General-Purpose Input and Output Port 0.4 (P0.4). SPI Master Out Slave In (MOSI). Programmable Logic Array for Input Element 11 (PLAI[11]). PWM Trip Interrupt (TRIP). The TRIP function of Pin E3 is the input that allows the PWM trip interrupt to be triggered.
F3	P0.5/ \overline{CS} /PLAI[10]/ADC _{CONVST}	I/O	General-Purpose Input and Output Port 0.5 (P0.5). SPI Slave Select Input (\overline{CS}). Programmable Logic Array for Input Element 10 (PLAI[10]). ADC Conversions (ADC _{CONVST}). The ADC _{CONVST} function of Pin F3 initiates the ADC conversions using the PLA or the timer output.
G3	P0.6/ \overline{MRST} /PLAI[2]	I/O	General-Purpose Input and Output Port 0.6 (P0.6). Power On Reset Output (\overline{MRST}). Programmable Logic Array for Input Element 2 (PLAI[2]).
G10	P0.7/ \overline{TRST} /PLAI[3]	I/O	General-Purpose Input and Output Port 0.7 (P0.7). JTAG Test Port Input, Test Reset (\overline{TRST}). Debug and download access. Programmable Logic Array for Input Element 3 (PLAI[3]).

Pin No.	Mnemonic	Type ¹	Description
C2	P1.0/SIN/SCL1/PLAI[7]	I/O	General-Purpose Input and Output Port 1.0 (P1.0). Serial Input, Receive Data, UART (SIN). I ² C Interface Serial Clock for I ² C1 (SCL1). Programmable Logic Array for Input Element 7 (PLAI[7]).
D2	P1.1/SOUT/SDA1/PLAI[6]	I/O	General-Purpose Input and Output Port 1.1 (P1.1). Serial Output, Transmit Data, UART (SOUT). I ² C Interface Serial Data for I ² C1 (SDA1). Programmable Logic Array for Input Element 6 (PLAI[6]).
C10	P1.2/TDI/PLAO[15]	DI	General-Purpose Input and Output Port 1.2 (P1.2). JTAG Test Port Input, Test Data In (TDI). The TDI function of Pin C10 is for debug and download access. Programmable Logic Array for Output Element 15 (PLAO[15]).
D10	P1.3/TDO/PLAO[14]	DO	General-Purpose Input and Output Port 1.3 (P1.3). JTAG Test Port Output, Test Data Out (TDO). The TDO function of Pin D10 is for debug and download access. Programmable Logic Array for Output Element 14 (PLAO[14]).
H3	P1.4/PWM1/ECLK/XCLK/PLAI[8]	I/O	General-Purpose Input and Output Port 1.4 (P1.4). Pulse-Width Modulator 1 Output (PWM1). Base System Clock Output (ECLK). Base System Clock Input (XCLK). Programmable Logic Array for Input Element 8 (PLAI[8]).
J3	P1.5/PWM2/PLAI[9]	I/O	General-Purpose Input and Output Port 1.5 (P1.5). Pulse-Width Modulator 2 Output (PWM2). Programmable Logic Array for Input Element 9 (PLAI[9]).
B3	P1.6/PLAO[5]	I/O	General-Purpose Input and Output Port 1.6 (P1.6). Programmable Logic Array for Output Element 5 (PLAO[5]).
B2	P1.7/PLAO[4]	I/O	General-Purpose Input and Output Port 1.7 (P1.7). Programmable Logic Array for Output Element 4 (PLAO[4]).
F11	P2.0/IRQ0/PLAI[13]	I/O	General-Purpose Input and Output Port 2.0 (P2.0)/External Interrupt Request 0, Active High. Programmable Logic Array for Input Element 13 (PLAI[13]).
G11	P2.1/IRQ1/PLAI[12]	I/O	General-Purpose Input and Output Port 2.1 (P2.1) External Interrupt Request 1, Active High (IRQ1). Programmable Logic Array for Input Element 12 (PLAI[12]).
H11	P2.2/PLAI[1]	I/O	General-Purpose Input and Output Port 2.2 (P2.2). Programmable Logic Array for Input Element 1 (PLAI[1]).
J11	P2.3/IRQ2/PLAI[14]	I/O	General-Purpose Input and Output Port 2.3 (P2.3). External Interrupt Request 2, Active High (IRQ2). Programmable Logic Array for Input Element 14 (PLAI[14]).
H10	P2.4/PWM5/PLAO[7]	I/O	General-Purpose Input and Output Port 2.4 (P2.4). Pulse-Width Modulator 5 Output (PWM5). Programmable Logic Array for Output Element 7 (PLAO[7]).
J10	P2.5/PWM6/PLAO[6]	I/O	General-Purpose Input and Output Port 2.5 (P2.5). Pulse-Width Modulator 6 Output (PWM6). Programmable Logic Array for Output Element 6 (PLAO[6]).
C1	P2.6/IRQ3/PLAI[15]	I/O	General-Purpose Input and Output Port 2.6 (P2.6). External Interrupt Request 3, Active High (IRQ3). Programmable Logic Array for Input Element 15 (PLAI[15]).
C9	P2.7/PLAI[0]	I/O	General-Purpose Input and Output Port 2.7 (P2.7).
C4	P3.0/PLAO[0]	I/O	General-Purpose Input and Output Port 3.0 (P3.0). Programmable Logic Array for Output Element 0 (PLAO[0]).
C11	P3.1/PLAO[1]	I/O	General-Purpose Input and Output Port 3.1 (P3.1). Programmable Logic Array for Output Element 1 (PLAO[1]).

ADuC7121

Pin No.	Mnemonic	Type ¹	Description
D1	P3.2/IRQ4/PWM3/PLAO[2]	I/O	General-Purpose Input and Output Port 3.2 (P3.2). External Interrupt Request 4, Active High (IRQ4). Pulse-Width Modulator 3 Output (PWM3). Programmable Logic Array for Output Element 2 (PLAO[2]).
E1	P3.3/IRQ5/PWM4/PLAO[3]	I/O	General-Purpose Input and Output Port 3.3 (P3.3). External Interrupt Request 5, Active High (IRQ5). Pulse-Width Modulator 4 Output (PWM4). Programmable Logic Array for Output Element 3 (PLAO[3]).
E2	P3.4/PLAO[8]	I/O	General-Purpose Input and Output Port 3.4 (P3.4). Programmable Logic Array for Output Element 8 (PLAO[8]).
F2	P3.5/PLAO[9]	I/O	General-Purpose Input and Output Port 3.5 (P3.5). Programmable Logic Array for Output Element 9 (PLAO[9]).
D12	P3.6/PLAO[10]	I/O	General-Purpose Input and Output Port 3.6 (P3.6). Programmable Logic Array for Output Element 10 (PLAO[10]).
E12	P3.7/ $\overline{\text{BM}}$ /PLAO[11]	I/O	General-Purpose Input and Output Port 3.7 (P3.7). Programmable Logic Array for Output Element 11 (PLAO[11]).
L8	V _{REF_2.5}	AI/O	2.5 V Reference Output and External 2.5 V Reference Input.
L5	V _{REF_1.2}	AI/O	1.2 V Reference Output and External 1.2 V Reference Input. Cannot be used to source current externally.
B8	I _{REF}	AI/O	Generates Reference Current for IDACs. Set by the external resistor, R _{EXT} .
K6	BUF_VREF1	AO	Buffered 2.5 V. The maximum load for BUF_VREF1 is 1.2 mA.
K7	BUF_VREF2	AO	Buffered 2.5 V. The maximum load for BUF_VREF2 is 1.2 mA.
L6	PADC0P	AI	PGA Channel 0+.
M5	PADC0N	AI	PGA Channel 0-.
L7	PADC1P	AI	PGA Channel 1+.
M8	PADC1N	AI	PGA Channel 1-.
K5	NC	NC	No Connect. Do not connect to this pin.
K4	NC	NC	No Connect. Do not connect to this pin.
M4	NC	NC	No Connect. Do not connect to this pin.
L4	NC	NC	No Connect. Do not connect to this pin.
K3	ADC4	AI	Single-Ended or Differential Analog Input 4.
M3	ADC5	AI	Single-Ended or Differential Analog Input 5.
M10	ADC6	AI	Single-Ended or Differential Analog Input 6.
M9	ADC7	AI	Single-Ended or Differential Analog Input 7.
L9	ADC8	AI	Single-Ended or Differential Analog Input 8.
K9	ADC9	AI	Single-Ended or Differential Analog Input 9.
K8	ADC10/AINCM	AI	Single-Ended or Differential Analog Input 10 (ADC10). Common Mode (AINCM). The common-mode function of this pin is for pseudo differential input.
K1	DAC0	AO	12-Bit DAC0 Output.
K2	DAC1	AO	12-Bit DAC1 Output.
J2	NC	NC	No Connect. Do not connect to this pin.
L2	NC	NC	No Connect. Do not connect to this pin.
M2	NC	NC	No Connect. Do not connect to this pin.
L3	NC	NC	No Connect. Do not connect to this pin.
M11	DAC2	AO	12-Bit DAC2 Output.
L11	NC	NC	No Connect. Do not connect to this pin.
L10	NC	NC	No Connect. Do not connect to this pin.
K10	NC	NC	No Connect. Do not connect to this pin.
K11	NC	NC	No Connect. Do not connect to this pin.
K12	DAC3	AO	12-Bit DAC3 Output.
B5	IDAC4	AO	IDAC4 Output. The maximum output for this pin is 20 mA.
C6	PVDD_IDAC4	S	2.0 V Power for IDAC4.

Pin No.	Mnemonic	Type ¹	Description
A6	C _{DAMP_IDAC4}	AI	Damping Capacitor Pin for IDAC4.
A8	IDAC3	AO	IDAC3 Output. The maximum output for this pin is 45 mA.
A7	PVDD_IDAC3	S	2.0 V Power for IDAC3.
C8	C _{DAMP_IDAC3}	AI	Damping Capacitor Pin for IDAC3.
A5	IDAC2	AO	IDAC2 Output. The maximum output for this pin is 80 mA.
C5	PVDD_IDAC2	S	2.0 V Power for the IDAC2.
B4	C _{DAMP_IDAC2}	AI	Damping Capacitor for IDAC2.
A4	IDAC1	AO	IDAC1 Output. The maximum output is 200 mA.
A1	IDAC1	AO	IDAC1 Output. The maximum output is 200 mA.
A3	PVDD_IDAC1	S	Power for IDAC1.
A2	PVDD_IDAC1	S	Power for IDAC1.
B1	C _{DAMP_IDAC1}	AI	Damping Capacitor for IDAC1.
A12	IDAC0	AO	IDAC0 Output. The maximum output is 250 mA.
A9	IDAC0	AO	IDAC0 Output. The maximum output is 250 mA.
A11	PVDD_IDAC0	S	Power for IDAC0.
A10	PVDD_IDAC0	S	Power for IDAC0.
B12	C _{DAMP_IDAC0}	AI	Damping Capacitor Pin for IDAC0.
B11	IDAC_TST	AI/O	IDAC Test Purposes.
B10	PGND	S	Power Ground.
B9	PGND	S	Power Ground.
M1	AGND	S	Analog Ground.
M6	AGND	S	Analog Ground.
L1	AVDD	S	Analog Supply (3.3 V).
M7	AVDD	S	Analog Supply (3.3 V).
M12	AGND	S	Analog Ground.
B6	AGND	S	Analog Ground.
L12	AVDD	S	Analog Supply (3.3 V).
C7	AVDD	S	Analog Supply (3.3 V).
B7	AVDD_IDAC	S	Output of 2.5 V LDO regulator for internal IDACs. A 470 nF capacitor to AGND must be connected to this pin.
G1	DVDD	S	Output of 2.6 V On-Chip LDO Regulator. A 470 nF capacitor to DGND must be connected to this pin.
G12	DVDD	S	Output of 2.6 V On-Chip LDO Regulator. A 470 nF capacitor to DGND must be connected to this pin.
F1	DGND	S	Digital Ground.
F12	DGND	S	Digital Ground.
H1	IOVDD	S	3.3 V GPIO Supply.
J1	IOGND	S	3.3 V GPIO Ground.
H12	IOVDD	S	3.3 V GPIO Supply.
J12	IOGND	S	3.3 V GPIO Ground.
G2	XTALO	DO	Crystal Oscillator Inverter Output. If an external crystal is not being used, this pin can remain unconnected.
H2	XTALI	DI	Crystal Oscillator Inverter Input and Internal Clock Generator Circuits Input. If an external crystal is not being used, connect this pin to the DGND system ground.
F10	TCK	DI	JTAG Test Port Input, Test Clock. Debug and download access.
E10	TMS	DI	JTAG Test Port Input, Test Mode Select. Debug and download access.

¹ A is analog, D is digital, I is input, O is output, and S is supply, NC is no connect.

TERMINOLOGY

ADC SPECIFICATIONS

Integral Nonlinearity

Integral nonlinearity (INL) is the maximum deviation of any code from a straight line passing through the endpoints of the ADC transfer function. The endpoints of the transfer function are zero scale, a point $\frac{1}{2}$ LSB below the first code transition, and full scale, a point $\frac{1}{2}$ LSB above the last code transition.

Differential Nonlinearity

Differential nonlinearity (DNL) is the difference between the measured and the ideal 1 LSB change between any two adjacent codes in the ADC.

Offset Error

Offset error is the deviation of the first code transition (0000 . . . 000) to (0000 . . . 001) from the ideal, that is, $+\frac{1}{2}$ LSB.

Gain Error

Gain error is the deviation of the last code transition from the ideal AIN voltage (full scale – 1.5 LSB) after the offset error has been adjusted out.

Signal to (Noise + Distortion) Ratio

Signal to (noise + distortion) ratio, or SINAD, is the measured ratio of signal to (noise + distortion) at the output of the ADC. The signal is the rms amplitude of the fundamental. Noise is the rms sum of all nonfundamental signals up to half the sampling frequency ($f_s/2$), excluding dc.

The ratio is dependent on the number of quantization levels in the digitization process: the more levels there are, the smaller the quantization noise becomes.

The theoretical SINAD ratio for an ideal N-bit converter with a sine wave input is given by

$$\text{Signal to (Noise + Distortion)} = (6.02 N + 1.76) \text{ dB}$$

Thus, for a 12-bit converter, this is 74 dB.

Total Harmonic Distortion

Total harmonic distortion (THD) is the ratio of the rms sum of the harmonics to the fundamental.

DAC SPECIFICATIONS

Relative Accuracy

Otherwise known as endpoint linearity, relative accuracy is a measure of the maximum deviation from a straight line passing through the endpoints of the DAC transfer function. It is measured after adjusting for zero error and full-scale error.

Voltage Output Settling Time

This is the amount of time it takes the output to settle to within a one LSB level for a full-scale input change.

OVERVIEW OF THE ARM7TDMI CORE

The ARM7™ core is a 32-bit reduced instruction set computer (RISC). It uses a single 32-bit bus for instruction and data. The length of the data can be 8 bits, 16 bits, or 32 bits. The length of the instruction word is 32 bits.

The ARM7TDMI® is an ARM7 core with four additional features, as follows:

- T support for the thumb (16-bit) instruction set
- D support for debug
- M support for long multiplications
- I includes the EmbeddedICE™ module to support embedded system debugging

THUMB MODE (T)

An ARM® instruction is 32 bits long. The ARM7TDMI processor supports a second instruction set that has been compressed into 16 bits, called the Thumb® instruction set. Faster execution from 16-bit memory and greater code density can usually be achieved by using the Thumb instruction set instead of the ARM instruction set, which makes the ARM7TDMI core particularly suitable for embedded applications.

However, the Thumb mode has two limitations, as follows:

- Thumb code typically requires more instructions for the same job. As a result, ARM code is usually best for maximizing the performance of time-critical code.
- The Thumb instruction set does not include some of the instructions needed for exception handling, which automatically switches the core to ARM code for exception handling.

See the ARM7TDMI user guide for details on the core architecture, the programming model, and both the ARM and ARM Thumb instruction sets.

LONG MULTIPLY (M)

The ARM7TDMI instruction set includes four extra instructions that perform 32-bit by 32-bit multiplication with a 64-bit result, and 32-bit by 32-bit multiplication accumulation (MAC) with a 64-bit result. These results are achieved in fewer cycles than required on a standard ARM7 core.

EmbeddedICE (I)

EmbeddedICE provides integrated on-chip support for the core. The EmbeddedICE module contains the breakpoint and watchpoint registers that allow code to be halted for debugging purposes. These registers are controlled through the JTAG test port.

When a breakpoint or watchpoint is encountered, the processor halts and enters debug state. When in a debug state, the processor registers can be inspected, as well as the Flash/EE, SRAM, and memory mapped registers.

EXCEPTIONS

ARM supports five types of exceptions and a privileged processing mode for each type. The five types of exceptions are

- Normal interrupt or IRQ. This is provided to service general-purpose interrupt handling of internal and external events.
- Fast interrupt or FIQ. This is provided to service data transfers or communication channels with low latency. FIQ has priority over IRQ.
- Memory abort.
- Attempted execution of an undefined instruction.
- Software interrupt instruction (SWI). This can be used to make a call to an operating system.

Typically, the programmer defines interrupt as IRQ, but for higher priority interrupt, that is, faster response time, the programmer can define interrupt as FIQ.

ARM REGISTERS

ARM7TDMI has a total of 37 registers: 31 general-purpose registers and 6 status registers. Each operating mode has dedicated banked registers.

When writing user level programs, 15 general-purpose 32-bit registers (R0 to R14), the program counter (R15), and the current program status register (CPSR) are usable. The remaining registers are used for system level programming and exception handling only.

When an exception occurs, some of the standard registers are replaced with registers specific to the exception mode. All exception modes have replacement banked registers for the stack pointer (R13) and the link register (R14) as represented in Figure 8. The fast interrupt mode has more registers (R8 to R12) for fast interrupt processing. This means that the interrupt processing can begin without the need to save or restore these registers, thus saving critical time in the interrupt handling process.

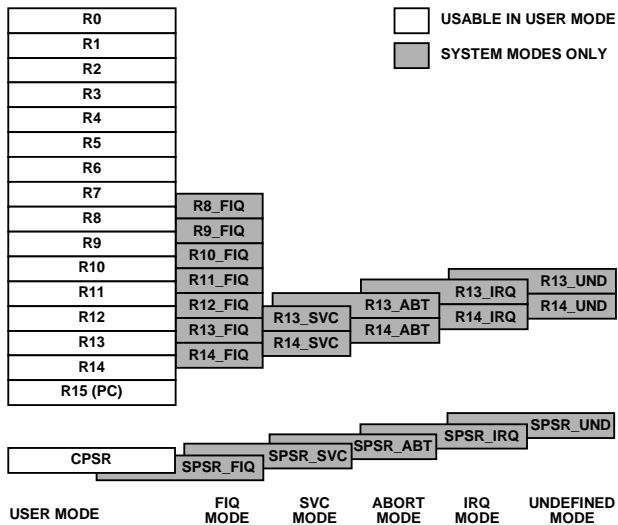

Figure 8. Register Organization

More information relative to the programmer's model and the ARM7TDMI core architecture can be found in the following materials from ARM, Ltd.:

- ARM DDI 0029G, *ARM7TDMI Technical Reference Manual*
- ARM DDI 0100, *ARM Architecture Reference Manual*

INTERRUPT LATENCY

The worst-case latency for a fast interrupt request (FIQ) consists of the following:

- The longest time the request can take to pass through the synchronizer.
- The time for the longest instruction to complete (the longest instruction is an LDM) that loads all the registers including the PC.
- The time for the data abort entry.
- The time for FIQ entry.

At the end of this time, the ARM7TDMI executes the instruction at 0x1C (FIQ interrupt vector address). The maximum total time is 50 processor cycles, which is just under 1.2 μ s in a system using a continuous 41.78 MHz processor clock.

The maximum interrupt request (IRQ) latency calculation is similar, but must allow for the fact that FIQ has higher priority and may delay entry into the IRQ handling routine for an arbitrary length of time. This time can be reduced to 42 cycles if the LDM command is not used. Some compilers have an option to compile without using this command. Another option is to run the part in Thumb mode wherein the time is reduced to 22 cycles.

The minimum latency for FIQ or IRQ interrupts is a total of five cycles, which consist of the shortest time the request can take through the synchronizer plus the time to enter the exception mode.

Note that the ARM7TDMI always runs in ARM (32-bit) mode when in privileged modes, for example, when executing interrupt service routines.

MEMORY ORGANIZATION

The ADuC7121 incorporates three separate blocks of memory: 8 kB of SRAM and two 64 kB of on-chip Flash/EE memory. There are 126 kB of on-chip Flash/EE memory available to the user, and the remaining 2 kB are reserved for the factory-configured boot page. These two blocks are mapped as shown in Figure 9.

Note that by default, after a reset, the Flash/EE memory is mirrored at Address 0x00000000. It is possible to remap the SRAM at Address 0x00000000 by clearing Bit 0 of the REMAP MMR. This remap function is described in more detail in the Flash/EE Memory section.

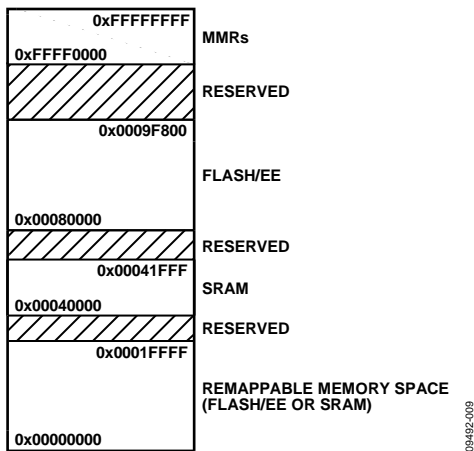

Figure 9. Physical Memory Map

MEMORY ACCESS

The ARM7 core sees memory as a linear array of 2^{32} byte locations where the different blocks of memory are mapped as outlined in Figure 9.

The ADuC7121 memory organization is configured in little endian format: the least significant byte is located in the lowest byte address and the most significant byte is located in the highest byte address.

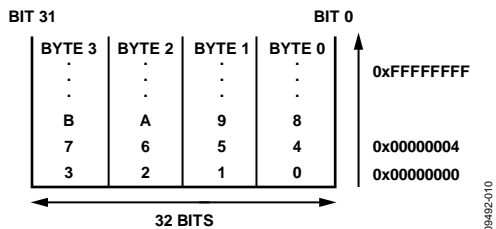

Figure 10. Little Endian Format

FLASH/EE MEMORY

The 128 kB of Flash/EE are organized as two banks of $32k \times 16$ bits. In the first block, $31k \times 16$ bits is user space and $1k \times 16$ bits is reserved for the factory configured boot page. The page size of this Flash/EE memory is 512 bytes.

The second 64 kB block is organized in a similar manner. It is arranged in $32k \times 16$ bits, all of which is available as user space.

The 126 kB of Flash/EE are available to the user as code and nonvolatile data memory. There is no distinction between data and program because ARM code shares the same space. The real width of the Flash/EE memory is 16 bits, meaning that in ARM mode (32-bit instruction), two accesses to the Flash/EE are necessary for each instruction fetch. Therefore, it is recommended that Thumb mode be used when executing from Flash/EE memory for optimum access speed. The maximum access speed for the Flash/EE memory is 41.78 MHz in Thumb mode and 20.89 MHz in full ARM mode (see the Execution Time from SRAM and FLASH/EE section).

SRAM

The 8 kB of SRAM are available to the user, organized as $2k \times 32$ bits, that is, 2k words. ARM code can run directly from SRAM at 41.78 MHz, given that the SRAM array is configured as a 32-bit wide memory array (see the Execution Time from SRAM and FLASH/EE section).

MEMORY MAPPED REGISTERS

The memory mapped register (MMR) space is mapped into the upper two pages of the memory array and accessed by indirect addressing through the ARM7 banked registers.

The MMR space provides an interface between the CPU and all on-chip peripherals. All registers, except the core registers, reside in the MMR area. All shaded locations shown in Figure 11 are unoccupied or reserved locations and should not be accessed by user software. Table 10 through Table 27 provide the complete MMR memory maps.

The access time reading or writing an MMR depends on the advanced microcontroller bus architecture (AMBA) bus used to access the peripheral. The processor has two AMBA buses: advanced high performance bus (AHB) used for system modules and advanced peripheral bus (APB) used for a lower performance peripheral. Access to the AHB is one cycle, and access to the APB is two cycles. All peripherals on the ADuC7121 are on the APB except the Flash/EE memory and the GPIOs.

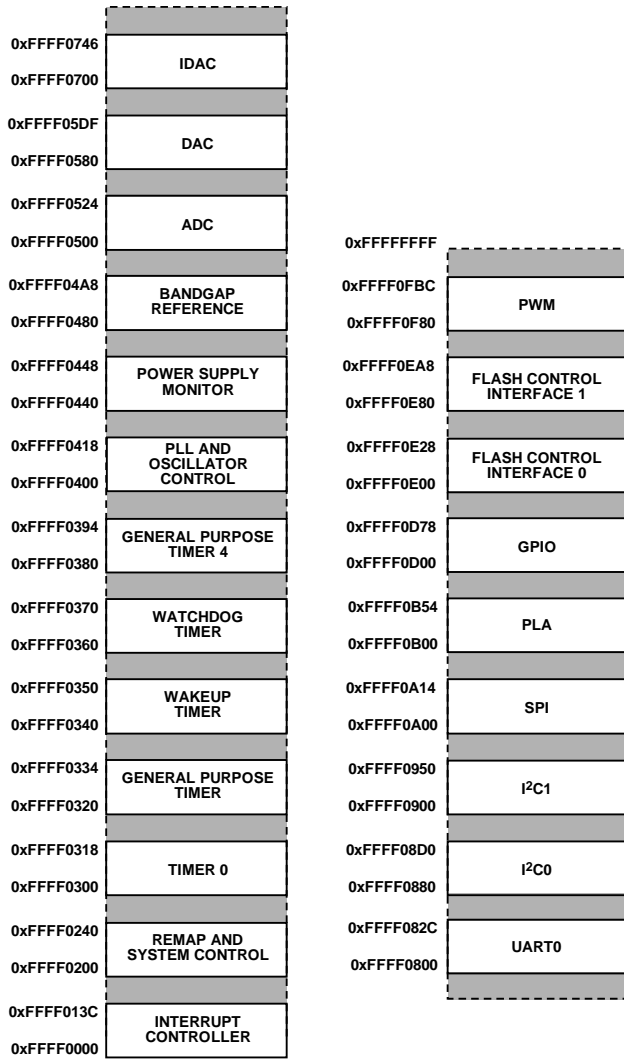

Figure 11. Memory Mapped Registers

COMPLETE MMR LISTING

Note that the Access Type column corresponds to the access time reading or writing an MMR, where R is read, W is write, and R/W is read/write. It depends on the AMBA bus that is used to access the peripheral. The processor has two AMBA buses: the advanced high performance bus (AHB) used for system modules and the advanced peripheral bus (APB) used for lower performance peripherals.

Table 10. IRQ Base Address = 0xFFFF0000

Address	Name	Byte	Access Type	Cycle
0x0000	IRQSTA	4	R	1
0x0004	IRQSIG	4	R	1
0x0008	IRQEN	4	R/W	1
0x000C	IRQCLR	4	R/W	1
0x0010	SWICFG	4	W	1
0x0014	IRQBASE	4	R/W	1
0x001C	IRQVEC	4	R/W	1
0x0020	IRQP0	4	R/W	1
0x0024	IRQP1	4	R/W	1
0x0028	IRQP2	4	R/W	1
0x002C	IRQP3	4	R/W	1
0x0030	IRQCONN	1	R/W	1
0x0034	IRQCONE	4	R/W	1
0x0038	IRQCLRE	1	W	1
0x003C	IRQSTAN	1	R/W	1
0x0100	FIQSTA	4	R	1
0x0104	FIQSIG	4	R	1
0x0108	FIQEN	4	R/W	1
0x010C	FIQCLR	4	W	1
0x011C	FIQVEC	4	R	1
0x013C	FIQSTAN	1	R/W	1

Table 11. System Control Base Address = 0xFFFF0200

Address	Name	Byte	Access Type	Cycle
0x0220	REMAP	1	R/W	1
0x0230	RSTSTA	1	R	1
0x0234	RSTCLR	1	W	1

Table 12. Timer Base Address = 0xFFFF0300

Address	Name	Byte	Access Type	Cycle
0x0300	T0LD	2	R/W	2
0x0304	T0VAL0	2	R	2
0x0308	T0VAL1	4	R	2
0x030C	T0CON	4	R/W	2
0x0310	T0CLRI	1	W	2
0x0314	T0CAP	2	R	2
0x0320	T1LD	4	R/W	2
0x0324	T1VAL	4	R	2
0x0328	T1CON	4	R/W	2
0x032C	T1CLRI	1	W	2
0x0330	T1CAP	4	R	2
0x0340	T2LD	4	R/W	2
0x0344	T2VAL	4	R	2
0x0348	T2CON	4	R/W	2
0x034C	T2CLRI	1	W	2
0x0360	T3LD	2	R/W	2
0x0364	T3VAL	2	R	2
0x0368	T3CON	2	R/W	2
0x036C	T3CLRI	1	W	2
0x0380	T4LD	4	R/W	2
0x0384	T4VAL	4	R	2
0x0388	T4CON	4	R/W	2
0x038C	T4CLRI	1	W	2
0x0390	T4CAP	4	R	2

Table 13. PLL Base Address = 0xFFFF0400

Address	Name	Byte	Access Type	Cycle
0x0404	POWKEY1	2	W	2
0x0408	POWCON	1	R/W	2
0x040C	POWKEY2	2	W	2
0x0410	PLLKEY1	2	W	2
0x0414	PLLCON	1	R/W	2
0x0418	PLLKEY2	2	W	2

Table 14. PSM Base Address = 0xFFFF0440

Address	Name	Byte	Access Type	Cycle
0x0440	PSMCON	2	R/W	2

Table 15. Reference Base Address = 0xFFFF0480

Address	Name	Byte	Access Type	Cycle
0x0480	REFCON	1	R/W	2

Table 16. ADC Base Address = 0xFFFF0500

Address	Name	Byte	Access Type	Cycle
0x0500	ADCCON	4	R/W	2
0x0504	ADCCP	1	R/W	2
0x0508	ADCCN	1	R/W	2
0x050C	ADCSTA	1	R	2
0x0510	ADCDAT	4	R	2
0x0514	ADCRST	1	W	2
0x0518	ADCGN	2	R/W	2
0x051C	ADCOF	2	R/W	2
0x0520	PGA_GN	2	R/W	2

Table 17. DAC Base Address = 0xFFFF0580

Address	Name	Byte	Access Type	Cycle
0x0580	DAC0CON	2	R/W	2
0x0584	DAC0DAT	4	R/W	2
0x0588	DAC1CON	2	R/W	2
0x058C	DAC1DAT	4	R/W	2
0x05B0	DAC2CON	2	R/W	2
0x05B4	DAC2DAT	4	R/W	2
0x05D8	DAC3CON	2	R/W	2
0x05DC	DAC3DAT	4	R/W	2

Table 18. IDAC Base Address = 0xFFFF0700

Address	Name	Byte	Access Type	Cycle
0x0700	IDAC0CON	2	R/W	2
0x0704	IDAC0DAT	4	R/W	2
0x0708	IDAC0BW	1	R/W	2
0x070C	IDAC1CON	2	R/W	2
0x0710	IDAC1DAT	4	R/W	2
0x0714	IDAC1BW	1	R/W	2
0x0718	IDAC2CON	2	R/W	2
0x071C	IDAC2DAT	4	R/W	2
0x0720	IDAC2BW	1	R/W	2
0x0724	IDAC3CON	2	R/W	2
0x0728	IDAC3DAT	4	R/W	2
0x072C	IDAC3BW	1	R/W	2
0x0730	IDAC4CON	2	R/W	2

Address	Name	Byte	Access Type	Cycle
0x0734	IDAC4DAT	4	R/W	2
0x0738	IDAC4BW	1	R/W	2
0x073C	TSDCON	1	R/W	2
0x0740	IDACSTA	1	R/W	2
0x0744	IDAC0PULLDOWN	1	R/W	2

Table 19. UART0 Base Address = 0xFFFF0800

Address	Name	Byte	Access Type	Cycle
0x0800	COMTX	1	W	2
	COMRX	1	R	2
	COMDIV0	1	R/W	2
0x0804	COMIEN0	1	R/W	2
	COMDIV1	1	R/W	2
0x0808	COMIID0	1	R	2
0x080C	COMCON0	1	R/W	2
0x0810	COMCON1	1	R/W	2
0x0814	COMSTA0	1	R	2
0x082C	COMDIV2	2	R/W	2

Table 20. I²C0 Base Address = 0xFFFF0880

Address	Name	Byte	Access Type	Cycle
0x0880	I2C0MCTL	2	R/W	2
0x0884	I2C0MSTA	2	R	2
0x0888	I2C0MRX	1	R	2
0x088C	I2C0MTX	2	W	2
0x0890	I2C0MCNT0	2	R/W	2
0x0894	I2C0MCNT1	1	R	2
0x0898	I2C0ADR0	1	R/W	2
0x089C	I2C0ADR1	1	R/W	2
0x08A0	I2C0SBYTE	1	R/W	2
0x08A4	I2C0DIV	2	R/W	2
0x08A8	I2C0SCTL	2	R/W	2
0x08AC	I2C0SSTA	2	R	2
0x08B0	I2C0SRX	1	R	2
0x08B4	I2C0STX	1	W	2
0x08B8	I2C0ALT	1	R/W	2
0x08BC	I2C0ID0	1	R/W	2
0x08C0	I2C0ID1	1	R/W	2
0x08C4	I2C0ID2	1	R/W	2
0x08C8	I2C0ID3	1	R/W	2
0x08CC	I2C0FSTA	1	R/W	2

Table 21. I²C1 Base Address = 0xFFFF0900

Address	Name	Byte	Access Type	Cycle
0x0900	I2C1MCTL	2	R/W	2
0x0904	I2C1MSTA	2	R	2
0x0908	I2C1MRX	1	R	2
0x090C	I2C1MTX	2	W	2
0x0910	I2C1MCNT0	2	R/W	2
0x0914	I2C1MCNT1	1	R	2
0x0918	I2C1ADR0	1	R/W	2
0x091C	I2C1ADR1	1	R/W	2
0x0920	I2C1SBYTE	1	R/W	2

ADuC7121

Address	Name	Byte	Access Type	Cycle
0x0924	I2C1DIV	2	R/W	2
0x0928	I2C1SCTL	2	R/W	2
0x092C	I2C1SSTA	2	R	2
0x0930	I2C1SRX	1	R	2
0x0934	I2C1STX	1	W	2
0x0938	I2C1ALT	1	R/W	2
0x093C	I2C1ID0	1	R/W	2
0x0940	I2C1ID1	1	R/W	2
0x0944	I2C1ID2	1	R/W	2
0x0948	I2C1ID3	1	R/W	2
0x094C	I2C1FSTA	1	R/W	2

Table 22. SPI Base Address = 0xFFFF0A00

Address	Name	Byte	Access Type	Cycle
0x0A00	SPISTA	2	R	2
0x0A04	SPIRX	1	R	2
0x0A08	SPITX	1	W	2
0x0A0C	SPIDIV	1	R/W	2
0x0A10	SPICON	2	R/W	2

Table 23. PLA Base Address = 0xFFFF0B00

Address	Name	Byte	Access Type	Cycle
0x0B00	PLAELM0	2	R/W	2
0x0B04	PLAELM1	2	R/W	2
0x0B08	PLAELM2	2	R/W	2
0x0B0C	PLAELM3	2	R/W	2
0x0B10	PLAELM4	2	R/W	2
0x0B14	PLAELM5	2	R/W	2
0x0B18	PLAELM6	2	R/W	2
0x0B1C	PLAELM7	2	R/W	2
0x0B20	PLAELM8	2	R/W	2
0x0B24	PLAELM9	2	R/W	2
0x0B28	PLAELM10	2	R/W	2
0x0B2C	PLAELM11	2	R/W	2
0x0B30	PLAELM12	2	R/W	2
0x0B34	PLAELM13	2	R/W	2
0x0B38	PLAELM14	2	R/W	2
0x0B3C	PLAELM15	2	R/W	2
0x0B40	PLAELM16	1	R/W	2
0x0B44	PLAIRQ	2	R/W	2
0x0B48	PLAADC	4	R/W	2
0x0B4C	PLADIN	4	R/W	2
0x0B50	PLAOUT	4	R	2
0x0B54	PLALCK	1	W	2

Table 24. GPIO Base Address = 0xFFFF0D00

Address	Name	Byte	Access Type	Cycle
0x0D00	GP0CON	4	R/W	1
0x0D04	GP1CON	4	R/W	1
0x0D08	GP2CON	4	R/W	1
0x0D0C	GP3CON	4	R/W	1
0x0D20	GP0DAT	4	R/W	1
0x0D24	GP0SET	1	W	1

Address	Name	Byte	Access Type	Cycle
0x0D28	GP0CLR	1	W	1
0x0D2C	GP0PAR	4	R/W	1
0x0D30	GP1DAT	4	R/W	1
0x0D34	GP1SET	1	W	1
0x0D38	GP1CLR	1	W	1
0x0D3C	GP1PAR	4	R/W	1
0x0D40	GP2DAT	4	R/W	1
0x0D44	GP2SET	1	W	1
0x0D48	GP2CLR	1	W	1
0x0D4C	GP2PAR	4	R/W	1
0x0D50	GP3DAT	4	R/W	1
0x0D54	GP3SET	1	W	1
0x0D58	GP3CLR	1	W	1
0x0D5C	GP3PAR	4	R/W	1

Table 25. Flash/EE Block 0 Base Address = 0xFFFF0E00

Address	Name	Byte	Access Type	Cycle
0x0E00	FEE0STA	1	R	1
0x0E04	FEE0MOD	1	R/W	1
0x0E08	FEE0CON	1	R/W	1
0x0E0C	FEE0DAT	2	R/W	1
0x0E10	FEE0ADR	2	R/W	1
0x0E18	FEE0SGN	3	R	1
0x0E1C	FEE0PRO	4	R/W	1
0x0E20	FEE0HID	4	R/W	1

Table 26. Flash/EE Block 1 Base Address = 0xFFFF0E80

Address	Name	Byte	Access Type	Cycle
0x0E80	FEE1STA	1	R	1
0x0E84	FEE1MOD	1	R/W	1
0x0E88	FEE1CON	1	R/W	1
0x0E8C	FEE1DAT	2	R/W	1
0x0E90	FEE1ADR	2	R/W	1
0x0E98	FEE1SGN	3	R	1
0x0E9C	FEE1PRO	4	R/W	1
0x0EA0	FEE1HID	4	R/W	1

Table 27. PWM Base Address= 0xFFFF0F80

Address	Name	Byte	Access Type	Cycle
0x0F80	PWMCON1	2	R/W	2
0x0F84	PWM1COM1	2	R/W	2
0x0F88	PWM1COM2	2	R/W	2
0x0F8C	PWM1COM3	2	R/W	2
0x0F90	PWM1LEN	2	R/W	2
0x0F94	PWM2COM1	2	R/W	2
0x0F98	PWM2COM2	2	R/W	2
0x0F9C	PWM2COM3	2	R/W	2
0x0FA0	PWM2LEN	2	R/W	2
0x0FA4	PWM3COM1	2	R/W	2
0x0FA8	PWM3COM2	2	R/W	2
0x0FAC	PWM3COM3	2	R/W	2
0x0FB0	PWM3LEN	2	R/W	2
0x0FB4	PWMCON2	2	R/W	2
0x0FB8	PWMICLR	2	W	2

ADC CIRCUIT OVERVIEW

The analog-to-digital converter (ADC) incorporates a fast, multichannel, 12-bit ADC. It can operate from a 3.0 V to 3.6 V supply and is capable of providing a throughput of up to 1 MSPS when the clock source is 41.78 MHz. This block provides the user with a multichannel multiplexer, a differential track-and-hold, an on-chip reference, and an ADC.

The ADC consists of a 12-bit successive approximation converter based around two capacitor DACs. Depending on the input signal configuration, the ADC can operate in one of the following three modes:

- Fully differential mode, for small and balanced signals.
- Single-ended mode, for any single-ended signals.
- Pseudo differential mode, for any single-ended signals, taking advantage of the common-mode rejection offered by the pseudo differential input.

The converter accepts an analog input range of 0 V to V_{REF} when operating in single-ended mode or pseudo differential mode. In fully differential mode, the input signal must be balanced around a common-mode voltage (V_{CM}) in the range of 0 V to AV_{DD} and with a maximum amplitude of $2 V_{REF}$ (see Figure 12).

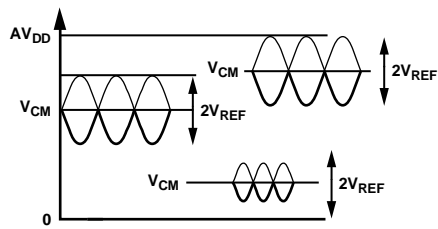

Figure 12. Examples of Balanced Signals for Fully Differential Mode

A high precision, low drift, and factory calibrated 2.5 V reference is provided on chip. An external reference can also be connected as described in the Band Gap Reference section.

Single or continuous conversion modes can be initiated in the software. An external ADC_{CONVST} pin, an output generated from the on-chip PLA, a Timer0, or a Timer1 overflow can also be used to generate a repetitive trigger for ADC conversions.

If the signal has not been deasserted by the time the ADC conversion is complete, a second conversion begins automatically.

A voltage output from an on-chip band gap reference proportional to absolute temperature can also be routed through the front-end ADC multiplexer, effectively creating an additional ADC channel input. This facilitates an internal temperature sensor channel, measuring die temperature to an accuracy of $\pm 3^\circ\text{C}$.

The ADuC7121 is modified in a way that differentiates its ADC structure from other devices in the ADuC702x family.

The PADC0x and PADC1x inputs connect to a PGA and allow for a gain from 1 to 5 with 32 steps. The remaining channels can be configured as single ended or differential. A buffer is provided before the ADC for measuring internal channels.

ADC TRANSFER FUNCTION

Pseudo Differential and Single-Ended Modes

For both pseudo differential and single-ended modes, the input range is 0 to V_{REF} . In addition, the output coding is straight binary in both pseudo differential and single-ended modes with

$$1 \text{ LSB} = FS/4096, \text{ or } 2.5 \text{ V}/4096 = 0.61 \text{ mV, or } 610 \mu\text{V} \\ \text{when } V_{REF} = 2.5 \text{ V}$$

The ideal code transitions occur midway between successive integer LSB values (that is, $1/2$ LSB, $3/2$ LSBs, $5/2$ LSBs, ..., $FS - 3/2$ LSBs). The ideal input/output transfer characteristic is shown in Figure 13.

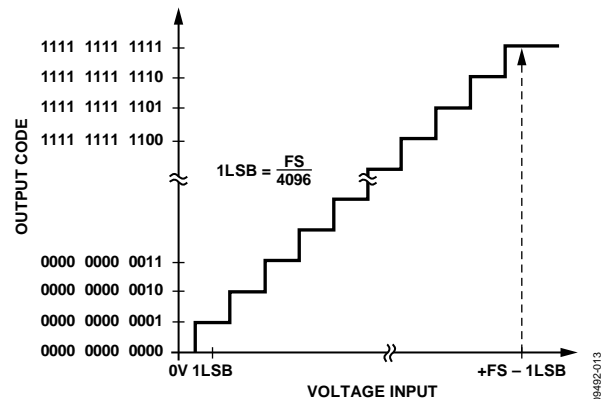

Figure 13. ADC Transfer Function in Pseudo Differential Mode or Single-Ended Mode

Fully Differential Mode

The amplitude of the differential signal is the difference between the signals applied to the V_{IN+} and V_{IN-} inputs (that is, $V_{IN+} - V_{IN-}$). Therefore, the maximum amplitude of the differential signal is $-V_{REF}$ to $+V_{REF}$ p-p ($2 \times V_{REF}$). This is regardless of the common mode (CM). The common mode is the average of the two signals $(V_{IN+} + V_{IN-})/2$, and is, therefore, the voltage that the two inputs are centered on, which results in the span of each input being $CM \pm V_{REF}/2$. This voltage must be set up externally, and its range varies with V_{REF} (see the Driving the Analog Inputs section).

The output coding is twos complement in fully differential mode with

$$1 \text{ LSB} = 2 V_{REF}/4096 \text{ or } 2 \times 2.5 \text{ V}/4096 = 1.22 \text{ mV when } V_{REF} = 2.5 \text{ V}$$

The output result is ± 11 bits, but this is shifted by one bit to the right. This allows the result in ADCDAT to be declared as a signed integer when writing C code. The designed code transitions occur midway between successive integer LSB values (that is, $1/2$ LSB, $3/2$ LSBs, $5/2$ LSBs, ..., $FS - 3/2$ LSBs). The ideal input/output transfer characteristic is shown in Figure 14.

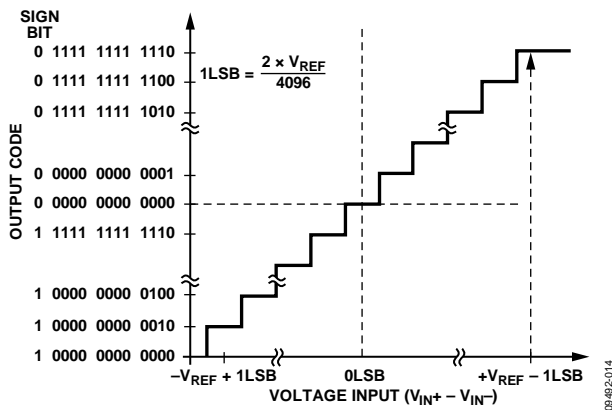

Figure 14. ADC Transfer Function in Differential Mode

PADC0x/PADC1x Pins

The PADC0x and PADC1x pins are differential input channels to the ADC that each have a programmable gain amplifier (PGA) on their front ends.

An external precision resistor converts the current to voltage and the PGA then amplifies this voltage signal with gain up to 5 by 32 steps. The intention is to compensate the variation of the detector diode responsivity and normalize optical power read by the ADC. The external resistor is assumed 0.1% accuracy, 5 ppm. A 1 nF capacitor is shunted with the resistor to suppress wideband noise. Select the resistor value such that the full-scale voltage developed on the resistor is less than $AV_{DD} - 1.2 \text{ V}$, or typically 1.8 V.

The PGA is designed to handle 10 mV minimum input. To minimize noise, bypass the ADC input buffer.

PADC0N is driven by a buffer to 0.15 V to keep the PGA from saturation when the input current drops to zero. The buffer can be disabled by setting the ADCCON Bit 14 so that the PADC0N pin can be connected to the ground plane as well. This is the same for the PADC1N pin.

The ADC needs to be placed in pseudo differential mode and assumes that the negative input is close to ground.

All of the controls are independently set through register bits for giving maximum flexibility to the user. Typically, users need to take the following steps (using PADC0x as an example):

1. Select PADC0N and PADC0P as the PGA input.
2. Select the PGA output as a MUX input.
3. Enable the PADC0N pin buffer.
4. Disable the ADC input buffer.
5. Set the proper gain value for the PGA.
6. Bypass the buffer.
7. Set the ADC to pseudo differential mode.
8. Start the conversion.

Other Input Channels

ADuC7121 contains seven extra ADC input pins. These pins can also be configured as differential input pairs or single-ended inputs, or pseudo differential inputs. The buffer and ADC are configured independently from the input channel selection. Note that the input range of the ADC input buffer is from 0.15 V to $AV_{DD} - 0.15 \text{ V}$; if the input signal range exceeds this range, the input buffer must be bypassed.

The ADuC7121 provides two pins for each thermistor input. The negative input removes the error of the ground difference. When selecting the thermistor input, always bypass the negative side buffer to ensure that the amplifier is not saturated. Configure the ADC to work in positive pseudo differential mode.

Besides these external inputs, the ADC can also select internal inputs to monitor three power supplies: IOVDD, PVDD_IDAC0, and PVDD_IDAC1. The voltage of the five IDAC outputs can also be monitored by the ADC by selecting the required channel in Register ADCCP. These internal signals are single-ended and can select AGND/PGND/IOGND as the negative input of the ADC via the ADCCN register.

Note that when monitoring IDAC outputs or PVDD_IDAC0, PVDD_IDAC1, or IOVDD_MON, the buffer must be enabled to isolate interference from ADC sampling.

An on-chip diode can also be selected to provide chip temperature monitoring. The ADC can also select V_{REF} and AGND as inputs for calibration purposes.

PGA and Input Buffer

The PGA is a one stage, positive gain amplifier that is able to accept input from 0.1 V to $AV_{DD} - 1.2 \text{ V}$, and the output swing should be at least 2.5 V. The gain of the PGA is from 1 to 5 with 32 linear steps. The PGA cannot be bypassed for the PADC0x and PADC1x channels.

The input level for PGA is limited to a maximum value of $AVDD - 1.2\text{ V}$ and minimum value of 0.1 V to ensure that the amplifiers are not saturated. The input buffer is a rail-to-rail buffer. It can accept signals from 0.15 to $AVDD - 0.15\text{ V}$. Both the positive and negative input buffers can be bypassed independently by setting ADCCON Bits[15:14].

Typical Operation

Once configured via the ADC control and channel selection registers, the ADC converts the analog input and provides a 12-bit result in the ADC data register.

The top four bits are the sign bits, and the 12-bit result is placed from Bit 27 to Bit 16, as shown in Figure 15. Again, note that, in fully differential mode, the result is represented in twos complement format, and when in pseudo differential and single-ended modes, the result is represented in straight binary format.

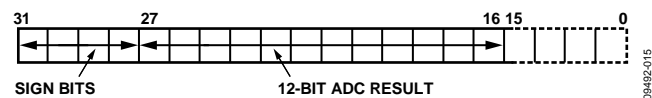

Figure 15. ADC Result Format

Timing

Figure 16 provides details of the ADC timing. Users control the ADC clock speed and the number of acquisition clocks in the ADCCON MMR. By default, the acquisition time is eight clocks and the clock divider is two. The number of additional clocks (such as bit trial or write) is set to 19, giving a sampling rate of 774 kSPS. For conversion on the temperature sensor, the ADC acquisition time is automatically set to 16 clocks and the ADC clock divider is set to 32. When using multiple channels, including the temperature sensor, the timing settings revert back to the user-defined settings after reading the temperature sensor channel.

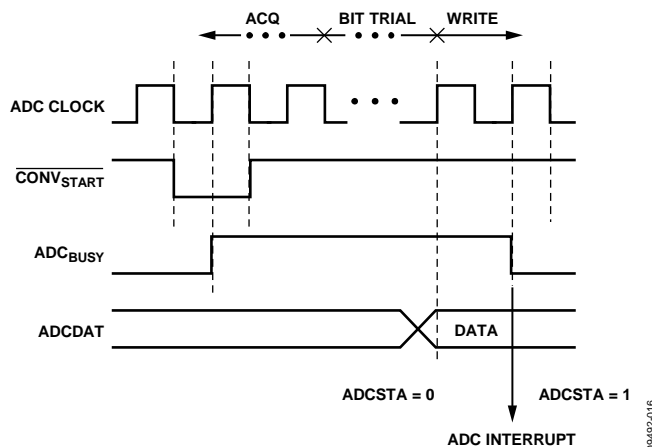

Figure 16. ADC Timing

TEMPERATURE SENSOR

The ADuC7121 provides a voltage output from an on-chip band gap reference proportional to absolute temperature. This voltage output can also be routed through the front-end ADC multiplexer (effectively, an additional ADC channel input),

facilitating an internal temperature sensor channel that measures die temperature.

The internal temperature sensor is not designed for use as an absolute ambient temperature calculator. It is intended for use as an approximate indicator of the temperature of the ADuC7121 die. The typical temperature coefficient is $-0.707\text{ mV}/^{\circ}\text{C}$.

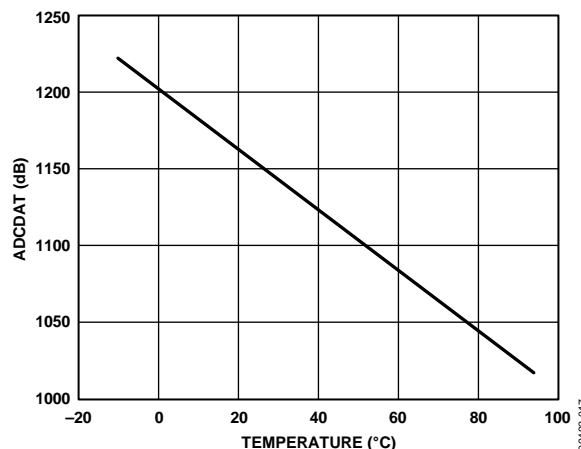

Figure 17. ADC Output vs. Temperature

ADC MMR Interface

The ADC is controlled and configured via a number of MMRs (see Table 28) that are described in detail in this section.

Table 28. ADC MMRs

Name	Description
ADCCON	ADC control register. ADCCON allows the programmer to enable the ADC peripheral, to select the mode of operation of the ADC (either single-ended, pseudo differential, or fully differential mode), and to select the conversion type (see Table 29).
ADCCP	ADC positive channel selection register.
ADCCN	ADC negative channel selection register.
ADCSTA	ADC status register. ADCSTA indicates when an ADC conversion result is ready. The ADCSTA register contains only one bit, ADCREADY (Bit 0), representing the status of the ADC. This bit is set at the end of an ADC conversion generating an ADC interrupt. It is cleared automatically by reading the ADCDAT MMR. When the ADC is performing a conversion, the status of the ADC can be read externally via the ADC _{Busy} function of Pin C3. This pin is high during a conversion. When the conversion is finished, ADC _{Busy} returns to low. This information can be available on P0.2 (see the General-Purpose Input/Output section) if enabled in the GP0CON register.
ADCDAT	ADC data result register. ADCDAT holds the 12-bit ADC result, as shown in Figure 15.
ADCRST	ADC reset register. ADCRST resets all of the ADC registers to their default values.
ADCGN	ADC gain calibration register for non-PGA channels.
ADCOF	ADC offset calibration register for all ADC channels.
PGA_GN	Gain of PGA_PADC0 and PGA_PADC1.

ADuC7121

Table 29. ADCCON MMR Bit Designations (Address = 0xFFFF0500, Default Value = 0x00000A00)

Bit	Value	Description
31:16		These bits are reserved.
15	0 1	Positive ADC buffer bypass. Set to 0 by the user to enable the positive ADC buffer. Set to 1 by the user to bypass the positive ADC buffer.
14	0 1	Negative ADC buffer bypass. Set to 0 by the user to enable the negative ADC buffer. Set to 1 by the user to bypass the negative ADC buffer.
13:11	000 001 010 011 100 101	ADC clock speed. $f_{ADC} = f_{CORE} \text{ Conversion} = 19 \text{ ADC Clocks} + \text{Acquisition Time}$ f _{ADC} divide-by-1. This divider is provided to obtain a 1 MSPS ADC with an external clock of <41.78 MHz. f _{ADC} divide-by-2 (default value). f _{ADC} divide-by-4. f _{ADC} divide-by-8. f _{ADC} divide-by-16. f _{ADC} divide-by-32.
10:8	000 001 010 011 100 101	ADC acquisition time (number of ADC clocks). 2 clocks. 4 clocks. 8 clocks (default value). 16 clocks. 32 clocks. 64 clocks.
7		Enable conversion. Set by the user to 1 to enable conversion mode. Cleared by the user to 0 to disable conversion mode.
6		Reserved. The user sets this bit to 0.
5	1 0	ADC power control. Set by the user to 1 to place the ADC in normal mode. The ADC must be powered up for at least 5 μs before it converts correctly. Cleared by the user to 0 to place the ADC in power-down mode.
4:3	00 01 10 11	Conversion mode. Single-ended mode. Differential mode. Pseudo differential mode. Reserved.
2:0	000 001 010 011 100 101 110 Other	Conversion type. Enable the ADC _{CONVST} function on Pin F3 as a conversion input. Enable Timer1 as a conversion input. Enable Timer0 as a conversion input. Single software conversion. Automatically set to 000 after conversion. Continuous software conversion. PLA conversion. PWM conversion. Reserved.

Table 30. ADCCP¹ MMR Bit Designations

Bit	Value	Description
7:5		Reserved
4:0		Positive channel selection bits
	00000	PADC0P
	00001	PADC1P
	00010	Reserved
	00011	Reserved
	00100	Reserved
	00101	Reserved
	00110	ADC4
	00111	ADC5
	01000	ADC6
	01001	ADC7
	01010	ADC8
	01011	ADC9
	01100	ADC10/AINCM
	01101	Temperature sensor
	01110	DVDD_IDAC0
	01111	DVDD_IDAC1
	10000	DVDD_IDAC2
	10001	DVDD_IDAC3
	10010	DVDD_IDAC4
	10011	IOVDD_MON
	10100	Reserved
	10101	Reserved
	10110	V _{REF}
	10111	AGND
	Others	Reserved

¹ ADC channel availability depends on part model.

Table 31. ADCCN¹ MMR Bit Designations

Bit	Value	Description
7:5		Reserved
4:0		Negative channel selection bits
	00000	PADC0N
	00001	PADC1N
	00010	Reserved
	00011	Reserved
	00100	Reserved
	00101	Reserved
	00110	ADC4
	00111	ADC5
	01000	ADC6
	01001	ADC7
	01010	ADC8
	01011	ADC9
	01100	ADC10/AINCM
	01101	V _{REF}
	01110	AGND
	01111	PGND
	10000	IOGND
	Others	Reserved

¹ ADC channel availability depends on part model.

Table 32. ADCSTA MMR Bit Designations

Bit	Value	Description
0	1	Indicates that an ADC conversion is complete. It is set automatically after an ADC conversion completes.
0	0	Automatically cleared by reading the ADCDAT MMR.

Table 33. ADCDAT MMR Bit Designations

Bit	Value	Description
27:16		Holds the ADC result (see Figure 15).

Table 34. ADCRST MMR Bit Designations

Bit	Value	Description
0	1	Set to 1 by the user to reset all the ADC registers to their default values.

Table 35. PGA_GN MMR Bit Designations¹

Bit	Value ²	Description
11:6	N/A	Gain of PGA for PADC0 = 1 + 4 × (PGA_PADC0_GN/32).
5:0	N/A	Gain of PGA for PADC1 = 1 + 4 × (PGA_PADC1_GN/32).

¹ PGA_PADC0_GN and PGA_PADC1_GN must be ≤ 32.

² N/A means not applicable.

Table 36. ADCGN MMR Bit Designations

Bit	Value ¹	Description
11:6	N/A	These bits are reserved.
9:0	N/A	10-bit ADC gain calibration value for non-PGA channels.

¹ N/A means not applicable.

Table 37. ADCOF MMR Bit Designations

Bit	Value ¹	Description
15:10	N/A	These bits are reserved.
9:0	N/A	10-bit ADC offset calibration value.

¹ N/A means not applicable.

CONVERTER OPERATION

The ADC incorporates a successive approximation (SAR) architecture involving a charge sampled input stage. This architecture is described for the three different modes of operation: differential, pseudo differential, and single-ended.

Differential Mode

The ADuC7121 contains a successive approximation ADC based on two capacitive DACs. Figure 18 and Figure 19 show simplified schematics of the ADC in acquisition and conversion phase, respectively. The ADC comprises control logic, a SAR, and two capacitive DACs. In Figure 18 (the acquisition phase), SW3 is closed and SW1 and SW2 are in Position A. The comparator is held in a balanced condition, and the sampling capacitor arrays acquire the differential signal on the input.

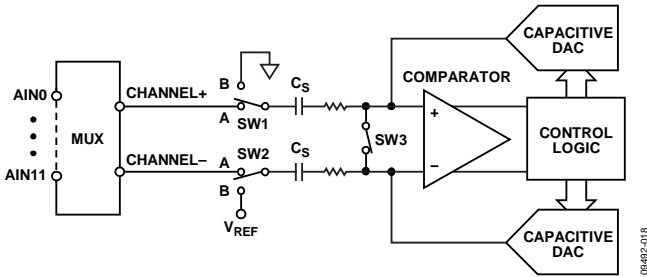

Figure 18. ADC Acquisition Phase

When the ADC starts a conversion (see Figure 19), SW3 opens, and SW1 and SW2 move to Position B, causing the comparator to become unbalanced. Both inputs are disconnected as soon as the conversion begins. The control logic and the charge redistribution DACs are used to add and subtract fixed amounts of charge from the sampling capacitor arrays to return the comparator to a balanced condition. When the comparator is rebalanced, the conversion is complete.

The control logic generates the ADC output code. The output impedances of the sources driving the V_{IN+} input and the V_{IN-} input must be matched; otherwise, the two inputs have different settling times, resulting in errors.

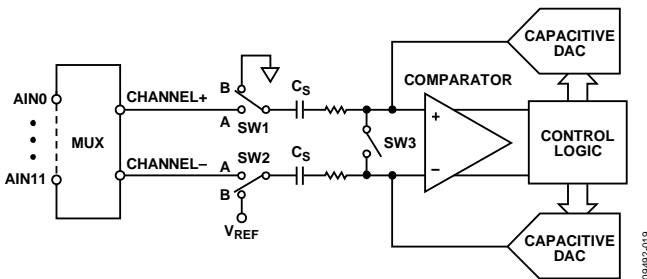

Figure 19. ADC Conversion Phase

Pseudo Differential Mode

In pseudo differential mode, Channel- is linked to the V_{IN-} input of the ADuC7121, and SW2 switches between A (Channel-) and B (V_{REF}). The V_{IN-} input must be connected to ground or a low voltage. The input signal on V_{IN+} can then vary from V_{IN-} to $V_{REF} + V_{IN-}$. Note that V_{IN-} must be chosen so that $V_{REF} + V_{IN-}$ does not exceed AV_{DD} .

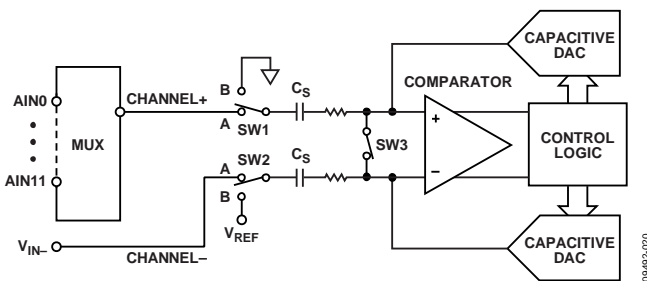

Figure 20. ADC in Pseudo Differential Mode

Single-Ended Mode

In single-ended mode, SW2 is always connected internally to ground. The V_{IN-} input pin can be floating. The input signal range on V_{IN+} is 0 V to V_{REF} .

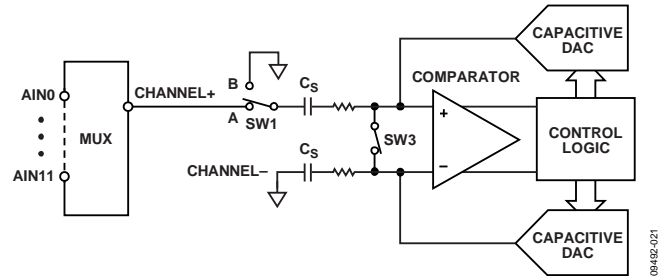

Figure 21. ADC in Single-Ended Mode

Analog Input Structure

Figure 22 shows the equivalent circuit of the analog input structure of the ADC. The four diodes provide ESD protection for the analog inputs. Take care to ensure that the analog input signals never exceed the supply rails by more than 300 mV. Voltage in excess of 300 mV causes these diodes to become forward biased and to start conducting into the substrate. These diodes can conduct up to 10 mA without causing irreversible damage to the part.

The C1 capacitors in Figure 22 are typically 4 pF and can be primarily attributed to pin capacitance. The resistors are lumped components made up of the on resistance of the switches. The value of these resistors is typically about 100 Ω . The C2 capacitors are the ADC sampling capacitors and have a capacitance of 16 pF typical.

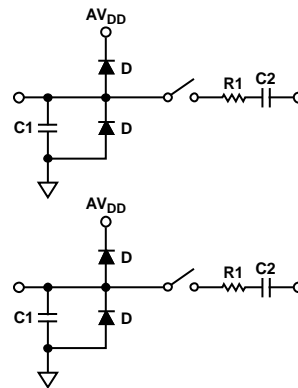

Figure 22. Equivalent Analog Input Circuit Conversion Phase: Switches Open, Track Phase: Switches Closed

For ac applications, removing high frequency components from the analog input signal is recommended with an RC low-pass filter on the relevant analog input pins. In applications where harmonic distortion and signal-to-noise ratio are critical, drive the analog input from a low impedance source. Large source impedances significantly affect the ac performance of the ADC and can necessitate the use of an input buffer amplifier. The choice of the op amp is a function of the particular application. Figure 23 and Figure 24 give an example of an ADC front end.

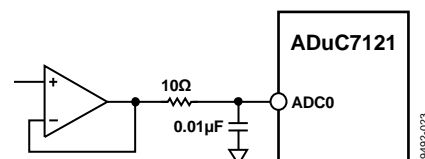

Figure 23. Buffering Single-Ended/Pseudo Differential Input

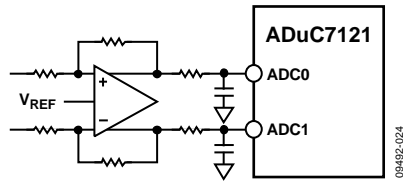

Figure 24. Buffering Differential Inputs

When no amplifier is used to drive the analog input, limit the source impedance to values lower than 1 k Ω . The maximum source impedance depends on the amount of total harmonic distortion (THD) that can be tolerated. The THD increases as the source impedance increases and the performance degrades.

DRIVING THE ANALOG INPUTS

An internal or external reference can be used for the ADC. In differential mode of operation, there are restrictions on the common-mode input signal (V_{CM}). These restrictions are dependent on the reference value and supply voltage used to ensure that the signal remains within the supply rails.

Table 38 gives some calculated V_{CM} minimum and V_{CM} maximum values.

Table 38. V_{CM} Ranges

AV_{DD}	V_{REF}	V_{CM} Min	V_{CM} Max	Signal Peak-to-Peak
3.3 V	2.5 V	1.25 V	2.05 V	2.5 V
	2.048 V	1.024 V	2.276 V	2.048 V
	1.25 V	0.75 V	2.55 V	1.25 V
3.0 V	2.5 V	1.25 V	1.75 V	2.5 V
	2.048 V	1.024 V	1.976 V	2.048 V
	1.25 V	0.75 V	2.25 V	1.25 V

Table 39. REFCON MMR Bit Designations (Address = 0xFFFF0480, Default Value = 0x01)

Bit	Description
7:1	Reserved.
2	BUF_VREF1/BUF_VREF2 is driven from the internal 2.5 V reference when set to 1.
1	Internal 2.5 V reference output enable. Set by the user to connect the internal 2.5 V reference to the $V_{REF_2.5}$ pin. Cleared by the user to disconnect the reference from the $V_{REF_2.5}$ pin. The $V_{REF_2.5}$ pin should also be cleared to connect an external reference source to it.
0	Internal 1.2 V reference output enable. Set by the user to connect the internal 1.2 V reference to the $V_{REF_1.2}$ pin. Cleared by the user to disconnect the reference from the $V_{REF_1.2}$ pin.

BAND GAP REFERENCE

The ADuC7121 provides an on-chip band gap reference of 2.5 V that can be used for the ADC and for the DAC. This 2.5 V reference is generated from a 1.2 V reference.

This internal reference also appears on the V_{REF} pins ($V_{REF_2.5}$ and $V_{REF_1.2}$). When using the internal reference, a capacitor of 0.47 μ F must be connected between each external V_{REF} pin and AGND to ensure stability and fast response during ADC conversions. This reference can also be connected to the external pin, BUF_VREF2, and used as a reference for other circuits in the system.

The band gap reference also connects through buffers to the BUF_VREF1 and the BUF_VREF2 pins. To damp the noise, connect a minimum of 0.1 μ F capacitor to these pins. The band gap reference interface consists of an 8-bit REFCON MMR, described in Table 39.

POWER SUPPLY MONITOR

The power supply monitor on the ADuC7121 indicates when the IOVDD supply pin drops below one of two supply trip points. The monitor function is controlled via the PSMCON register. If enabled in the IRQEN or FIQEN register, the monitor interrupts the core using the PSMI bit in the PSMCON MMR. This bit is cleared immediately after CMP goes high. Note that if the interrupt generated is exited before CMP goes high (IOVDD supply voltage is above the trip point), no further

interrupts are generated until CMP returns high. The user needs to ensure that the code execution remains within the ISR until CMP returns high.

This monitor function allows the user to save working registers to avoid possible data loss due to low supply or brownout conditions. It also ensures that normal code execution does not resume until a safe supply level has been established.

The PSM does not operate correctly when using JTAG debug; therefore, disable PSM while in JTAG debug mode.

Table 40. PSMCON MMR Bit Designations (Address = 0xFFFF0440, Default Value = 0x0008)

Bit	Name	Description
15:4	Reserved	These bits are reserved.
3	CMP	Comparator bit. This is a read-only bit that directly reflects the state of the comparator. Read 1 indicates that the IOVDD supply is above its selected trip point or the PSM is in power-down mode. Read 0 indicates the IOVDD supply is below its selected trip point. Set this bit before leaving the interrupt service routine.
2	TP	Trip point selection bit. 0 = 2.79 V. 1 = 3.07 V.
1	PSMEN	Power supply monitor enable bit. Set to 1 by the user to enable the power supply monitor circuit. Cleared to 0 by the user to disable the power supply monitor circuit.
0	PSMI	Power supply monitor interrupt bit. This bit is set high by the MicroConverter if CMP is low, indicating low I/O supply. The PSMI bit can be used to interrupt the processor. When CMP returns high, the PSMI bit can be cleared by writing a 1 to this location. A write of 0 has no effect. There is no timeout delay. PSMI can be cleared immediately after CMP goes high.

NONVOLATILE FLASH/EE MEMORY

FLASH/EE MEMORY OVERVIEW

The ADuC7121 incorporates Flash/EE memory technology on chip to provide the user with nonvolatile, in circuit reprogrammable memory space.

Similar to EEPROM, flash memory can be programmed in system at a byte level, although it must first be erased. The erase is performed in page blocks. As a result, flash memory is often (and more correctly) referred to as Flash/EE memory.

Overall, Flash/EE memory represents a step closer to the ideal memory device that includes no volatility, in circuit programmability, high density, and low cost. Incorporated in the ADuC7121, Flash/EE memory technology allows the user to update program code space in circuit, without the need to replace one time programmable (OTP) devices at remote operating nodes.

FLASH/EE MEMORY

The ADuC7121 contains two 64 kB arrays of Flash/EE memory. In the first block, the lower 62 kB is available to the user and the upper 2 kB of this Flash/EE memory array program contain permanently embedded firmware, allowing in circuit serial download. The 2 kB of embedded firmware also contain a power-on configuration routine that downloads factory calibrated coefficients to the various calibrated peripherals (band gap references and so forth). This 2 kB embedded firmware is hidden from user code. It is not possible for the user to read, write, or erase this page.

In the second block, all 64 kB of Flash/EE memory are available to the user.

The 126 kB of Flash/EE memory can be programmed in circuit using the serial download mode or the JTAG mode.

Flash/EE Memory Reliability

The Flash/EE memory arrays on the ADuC7121 are fully qualified for two key Flash/EE memory characteristics: Flash/EE memory cycling endurance and Flash/EE memory data retention.

Endurance quantifies the ability of the Flash/EE memory to be cycled through many program, read, and erase cycles. A single endurance cycle is composed of four independent, sequential events, defined as follows:

1. Initial page erase sequence
2. Read/verify sequence a single Flash/EE
3. Byte program sequence memory
4. Second read/verify sequence endurance cycle

In reliability qualification, every half word (16-bit wide) location of the three pages (top, middle, and bottom) in the Flash/EE memory is cycled 10,000 times from 0x0000 to 0xFFFF.

As indicated in the Specifications section, the Flash/EE memory endurance qualification is carried out in accordance with JEDEC Retention Lifetime Specification A117 over the

industrial temperature range of -10° to $+95^{\circ}\text{C}$. The results allow the specification of a minimum endurance figure over a supply temperature of 10,000 cycles.

Retention quantifies the ability of the Flash/EE memory to retain its programmed data over time. Again, the parts are qualified in accordance with the formal JEDEC Retention Lifetime Specification A117 at a specific junction temperature ($T_J = 85^{\circ}\text{C}$). As part of this qualification procedure, the Flash/EE memory is cycled to its specified endurance limit, described previously, before data retention is characterized. This means that the Flash/EE memory is guaranteed to retain its data for its fully specified retention lifetime every time the Flash/EE memory is reprogrammed. Note, too, that retention lifetime, based on activation energy of 0.6 eV, derates with T_J , as shown in Figure 25.

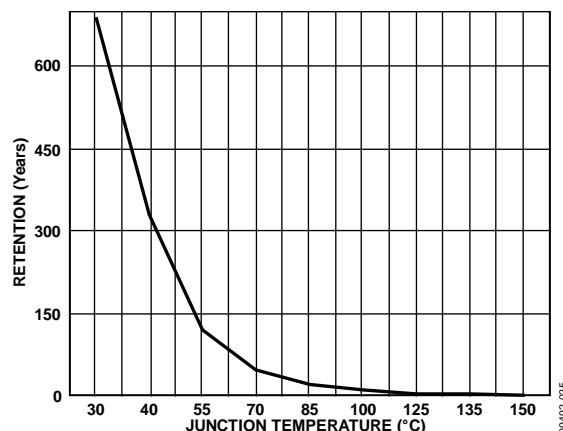

Figure 25. Flash/EE Memory Data Retention

Serial Downloading (In-Circuit Programming)

The ADuC7121 facilitates code download via the I²C serial port. The ADuC7121 enters serial download mode after a reset or power cycle if the BM function of the P3.7/BM/PLAO[11] pin is pulled low through an external 1 kΩ resistor. This is combined with the state of Address 0x00014 in the flash. If this address is 0xFFFFFFFF and BM is pulled low, the part enters download mode; if this address contains any other value, user code is executed. When in serial download mode, the user can download code to the full 126 kB of Flash/EE memory while the device is in circuit in its target application hardware. A PC serial download executable and hardware dongle are provided as part of the development system for serial downloads via the I²C port.

JTAG Access

The JTAG protocol uses the on-chip JTAG interface to facilitate code download and debug.

FLASH/EE MEMORY SECURITY

The 126 kB of Flash/EE memory available to the user can be read and write protected. Bit 31 of the FEE0PRO/FEE0HID MMR protects the 126 kB from being read through JTAG and also in I²C programming mode. The other 31 bits of this register protect

writing to the Flash/EE memory; each bit protects four pages, that is, 2 kB. Write protection is activated for all access types. FEE1PRO and FEE1HID similarly protect the second 64 kB block. All 32 bits of this are used to protect four pages at a time.

Three Levels of Protection

Protection can be set and removed by writing directly into the FEEExHID MMR. This protection does not remain after reset.

Protection can be set by writing into the FEEExPRO MMR. It takes effect only after a save protection command (0x0C) and a reset. The FEEExPRO MMR is protected by a key to avoid direct access. The key is saved one time only and must be reentered to modify FEEExPRO. A mass erase sets the key back to 0xFFFF but also erases all the user code.

The Flash/EE memory can be permanently protected by using the FEEPRO MMR and a particular value of the 0xDEADDEAD key. Entering the key again to modify the FEEExPRO register is not allowed.

Sequence to Write the Key to Protection Registers

1. Write the bit in FEEExPRO corresponding to the page to be protected.
2. Enable key protection by setting Bit 6 of FEEExMOD (Bit 5 must equal 0).
3. Write a 32-bit key in FEEExADR, FEEExDAT.
4. Run the write key command 0x0C in FEEExCON; wait for the read to be successful by monitoring FEEExSTA.
5. Reset the part.

To remove or modify the protection, the same sequence is used with a modified value of FEEExPRO. If the key chosen is the value 0xDEAD, then the memory protection cannot be removed. Only a mass erase unprotects the part, but it also erases all user code.

The sequence to write the key is shown in the following example; this protects writing Page 4 to Page 7 of the Flash/EE memory:

```
FEE0PRO=0xFFFFFFFFD; //Protect Page 4 to Page 7
FEE0MOD=0x48; //Write key enable
FEE0ADR=0x1234; //16-bit key value
FEE0DAT=0x5678; //16-bit key value
FEE0CON= 0x0C; //Write key command
```

Follow the same sequence to permanently protect the part with FEEExADR = 0xDEAD and FEEExDAT = 0xDEAD.

FLASH/EE CONTROL INTERFACE

FEE0DAT Register

FEE0DAT is a 16-bit data register.

Name: FEE0DAT
Address: 0xFFFF0E0C
Default value: 0XXXXX
Access: Read and write

FEE0ADR Register

FEE0ADR is a 16-bit address register.

Name: FEE0ADR
Address: 0xFFFF0E10
Default value: 0x0000
Access: Read and write

FEE0SGN Register

FEE0SGN is a 24-bit code signature.

Name: FEE0SGN
Address: 0xFFFF0E18
Default value: 0FFFFFFF
Access: Read only

FEE0PRO Register

FEE0PRO provides protection following subsequent reset MMR. It requires a software key (see Table 41).

Name: FEE0PRO
Address: 0xFFFF0E1C
Default value: 0x00000000
Access: Read and write

FEE0HID Register

FEE0HID provides immediate protection MMR. It does not require any software keys (see Table 41).

Name: FEE0HID
Address: 0xFFFF0E20
Default value: 0xFFFFFFFF
Access: Read and write.

Table 41. FEE0PRO and FEE0HID MMR Bit Designations

Bit	Description
31	Read protection. Cleared by the user to protect Block 0. Set by the user to allow reading Block 0.
30:0	Write protection for Page 123 to Page 120, for Page 119 to Page 116, and for Page 0 to Page 3. Cleared by the user to protect the pages in writing. Set by the user to allow writing the pages.

Command Sequence for Executing a Mass Erase

```
FEE0DAT = 0x3CFF;
FEE0ADR = 0xFFC3;
FEE0MOD = FEE0MOD|0x8; //Erase key enable
FEE0CON = 0x06; //Mass erase command
```

FEE1DAT Register

FEE1DAT is a 16-bit data register.

Name: FEE1DAT
Address: 0xFFFF0E8C
Default value: 0XXXXX
Access: Read and write

FEE1ADR Register

FEE1ADR is a 16-bit address register.

Name: FEE1ADR
Address: 0xFFFF0E90
Default value: 0x0000
Access: Read and write

FEE1SGN Register

FEE1SGN is a 24-bit code signature.

Name: FEE1SGN
Address: 0xFFFF0E98
Default value: 0FFFFFFF
Access: Read only

FEE1PRO Register

FEE1PRO provides protection following subsequent reset MMR. It requires a software key (see Table 42).

Name: FEE1PRO
Address: 0xFFFF0E9C
Default value: 0x00000000
Access: Read and write

FEE1HID Register

FEE1HID provides immediate protection MMR. It does not require any software keys (see Table 42).

Name: FEEHID
Address: 0xFFFF0EA0
Default value: 0FFFFFFF
Access: Read and write

Table 42. FEE1PRO and FEE1HID MMR Bit Designations

Bit	Description
31	Read protection. Cleared by the user to protect Block 1. Set by the user to allow reading Block 1.
30	Write protection for Page 127 to Page 120. Cleared by the user to protect the pages in writing. Set by the user to allow writing the pages.
29:0	Write protection for Page 119 to Page 116 and for Page 0 to Page 3. Cleared by the user to protect the pages in writing. Set by the user to allow writing the pages.

FEE0STA Register

Name: FEE0STA
Address: 0xFFFF0E00
Default value: 0x0000
Access: Read and write

FEE1STA Register

Name: FEE1STA
Address: 0xFFFF0E80
Default value: 0x0000
Access: Read and write

Table 43. FEEExSTA MMR Bit Designations

Bit	Description
15:6	Reserved.
5	Reserved.
4	Reserved.
3	Flash/EE interrupt status bit. Set automatically when an interrupt occurs, that is, when a command is complete and the Flash/EE interrupt enable bit in the FEEExMOD register is set. Cleared when reading FEEExSTA register.
2	Flash/EE controller busy. Set automatically when the controller is busy. Cleared automatically when the controller is not busy.

ADuC7121

Bit	Description
1	Command fail. Set automatically when a command completes unsuccessfully. Cleared automatically when reading FEEExSTA register.
0	Command complete. Set by MicroConverter when a command is complete. Cleared automatically when reading FEEExSTA register.

FEE0MOD Register

Name: FEE0MOD
Address: 0xFFFFF0E04
Default value: 0x80
Access: Read and write

FEE1MOD Register

Name: FEE1MOD
Address: 0xFFFFF0E84
Default value: 0x80
Access: Read and write

Table 44. FEEExMOD MMR Bit Designations

Bit	Description
7:5	Reserved. These bits are always set to 0 except when writing keys. See the Sequence to Write the Key to Protection Registers section for details.
4	Flash/EE interrupt enable. Set by the user to enable the Flash/EE interrupt. The interrupt occurs when a command is complete. Cleared by the user to disable the Flash/EE interrupt.
3	Erase/write command protection. Set by the user to enable the erase and write commands. Cleared to protect the Flash/EE memory against erase/write command.
2	Reserved. The user must set this bit to 0.
1:0	Flash/EE wait states. Both Flash/EE blocks must have the same wait state value for any change to take effect.

FEE0CON Register

Name: FEE0CON
Address: 0xFFFFF0E08
Default value: 0x00
Access: Read and write

FEE1CON Register

Name: FEE1CON
Address: 0xFFFFF0E88
Default value: 0x00
Access: Read and write

Table 45. Command Codes in FEEExCON

Code	Command	Description
0x00 ¹	Null	Idle state.
0x01 ¹	Single read	Load FEEExDAT with the 16-bit data indexed by FEEExADR.
0x02 ¹	Single write	Write FEEExDAT at the address pointed by FEEExADR. This operation takes 50 μ s.
0x03 ¹	Erase/write	Erase the page indexed by FEEExADR and write FEEExDAT at the location pointed by FEEExADR. This operation takes 20 ms.
0x04 ¹	Single verify	Compare the contents of the location pointed by FEEExADR to the data in FEEExDAT. The result of the comparison is returned in FEEExSTA Bit 1.
0x05 ¹	Single erase	Erase the page indexed by FEEExADR.
0x06 ¹	Mass erase	Erase user space. The 2 kB of kernel are protected in Block 0. This operation takes 2.48 sec. To prevent accidental execution, a command sequence is required to execute this instruction.
0x07	Reserved	Reserved.
0x08	Reserved	Reserved.
0x09	Reserved	Reserved.
0x0A	Reserved	Reserved.
0x0B	Signature	Gives a signature of the 64 kB of Flash/EE in the 24-bit FEEExSIGN MMR. This operation takes 32,778 clock cycles.
0x0C	Protect	This command can be run only once. The value of FEEExPRO is saved and can be removed only with a mass erase (0x06) or with the key.
0x0D	Reserved	Reserved.
0x0E	Reserved	Reserved.
0x0F	Ping	No operation, interrupt generated.

¹ The FEEExCON register always reads 0x07 immediately after execution of any of these commands.

EXECUTION TIME FROM SRAM AND FLASH/EE

This section describes SRAM and Flash/EE access times during execution for applications where execution time is critical.

Execution from SRAM

Fetching instructions from SRAM takes one clock cycle because the access time of the SRAM is 2 ns and a clock cycle is 22 ns minimum. However, if the instruction involves reading or writing data to memory, one extra cycle must be added if the data is in SRAM (or three cycles if the data is in Flash/EE), one cycle to execute the instruction, and two cycles to retrieve the 32-bit data from Flash/EE. A control flow instruction, such as a branch instruction, takes one cycle to fetch, but it also takes two cycles to fill the pipeline with the new instructions.

Execution from Flash/EE

Because the Flash/EE width is 16 bits and access time for 16-bit words is 23 ns, execution from Flash/EE cannot be accomplished in one cycle (as can be done from SRAM when the CD bit = 0). In addition, some dead times are needed before accessing data for any value of CD bits.

In ARM mode, where instructions are 32 bits, two cycles are needed to fetch any instruction when CD = 0. In Thumb mode, where instructions are 16 bits, one cycle is needed to fetch any instruction.

Timing is identical in both modes when executing instructions that involve using the Flash/EE for data memory. If the instruction to be executed is a control flow instruction, an extra cycle is needed to decode the new address of the program counter and then four cycles are needed to fill the pipeline. A data processing instruction involving only core registers does not require any extra clock cycles, but if it involves data in Flash/EE, one additional clock cycle is needed to decode the address of the data and two additional cycles are needed to obtain the 32-bit data from Flash/EE. An extra cycle must also be added before fetching another instruction. Data transfer instructions are more complex and are summarized in Table 46.

Table 46. Execution Cycles in ARM/Thumb Mode

Instructions	Fetch Cycles	Dead Time	Data Access	Dead Time
LD	2/1	1	2	1
LDH	2/1	1	1	1
LDM/PUSH	2/1	N	2 × N	N
STR	2/1	1	2 × 20 μs	1
STRH	2/1	1	20 μs	1
STRM/POP	2/1	N	2 × N × 20 μs	N

With $1 < N \leq 16$, N is the number of bytes of data to load or store in the multiple load/store instruction. The SWAP instruction combines an LD and STR instruction with only one fetch, giving a total of eight cycles plus 40 μs.

RESET AND REMAP

The ARM exception vectors are situated at the bottom of the memory array, from Address 0x00000000 to Address 0x00000020, as shown in Figure 26.

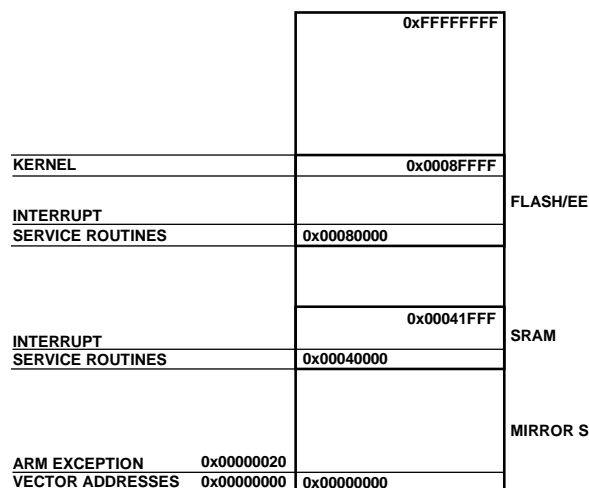

Figure 26. Remap for Exception Execution

By default and after any reset, the Flash/EE is mirrored at the bottom of the memory array. The remap function allows the programmer to mirror the SRAM at the bottom of the memory array, facilitating execution of exception routines from SRAM instead of from Flash/EE. This means exceptions are executed twice as fast, with the exception being executed in ARM mode (32 bits), and the SRAM being 32 bits wide instead of being 16-bit wide Flash/EE memory.

Remap Operation

When a reset occurs on the ADuC7121, execution starts automatically in factory programmed internal configuration code. This kernel is hidden and cannot be accessed by user code.

If the ADuC7121 is in normal mode (the P3.7/BM/PLAO[11] pin is high), it executes the power-on configuration routine of the kernel and then jumps to the Reset Vector Address 0x00000000 to execute the user's reset exception routine. Because the Flash/EE is mirrored at the bottom of the memory array at reset, the reset interrupt routine must always be written in Flash/EE.

The remap is performed from Flash/EE by setting Bit 0 of the remap register. Precautions must be taken to execute this command from Flash/EE (above Address 0x00080020) and not from the bottom of the array because this, the defined memory space, is replaced by the SRAM.

This operation is reversible: the Flash/EE can be remapped at Address 0x00000000 by clearing Bit 0 of the remap MMR. Precaution must again be taken to execute the remap function from outside the mirrored area. Any kind of reset remaps the Flash/EE memory at the bottom of the array.

ADuC7121

Reset Operation

There are four types of reset: external reset, power-on reset, watchdog expiration, and software force. The RSTSTA register indicates the source of the last reset and RSTCLR clears the RSTSTA register. These registers can be used during a reset

exception service routine to identify the source of the reset. If RSTSTA is null, the reset was external. Note that when clearing RSTSTA, all bits that are currently set to 1 must be cleared. Otherwise, a reset event occurs.

Table 47. Remap MMR Bit Designations (Address = 0xFFFF0220, Default Value = 0x00)

Bit	Name	Description
0	Remap	Remap bit. Set by the user to remap the SRAM to Address 0x00000000. Cleared automatically after reset to remap the Flash/EE memory to Address 0x00000000.

Table 48. RSTSTA MMR Bit Designations (Address = 0xFFFF0230, Default Value = 0x0X)

Bit	Description
7:3	Reserved.
2	Software reset. Set by the user to force a software reset. Cleared by setting the corresponding bit in RSTCLR.
1	Watchdog timeout. Set automatically when a watchdog timeout occurs. Cleared by setting the corresponding bit in RSTCLR.
0	Power-on reset. Set automatically when a power-on reset occurs. Cleared by setting the corresponding bit in RSTCLR.

OTHER ANALOG PERIPHERALS

DIGITAL-TO-ANALOG CONVERTERS

The ADuC7121 incorporates four buffered 12-bit voltage output string digital-to-analog converters (DACs) on chip. Each DAC has a rail-to-rail voltage output buffer capable of driving 5 kΩ/100 pF.

Each DAC has three selectable ranges: 0 V to V_{REF} (internal band gap 2.5 V reference), 0 V to AV_{DD} , and 0 V to EXT_REF

(see Figure 27). The signal range is 0 V to AV_{DD} . Note that the DAC can also operate in interpolation mode.

MMR Interfaces

Each DAC is independently configurable through a control register and a data register. These two registers are identical for the 12 DACs. Only DAC0CON and DAC0DAT are described in detail in this section.

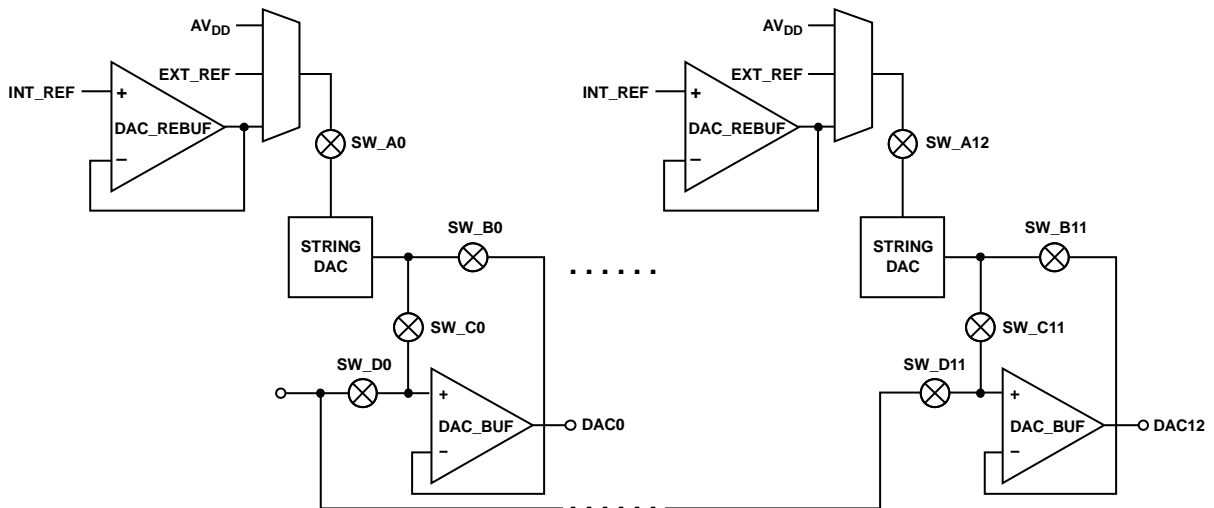

Figure 27. DAC Configuration

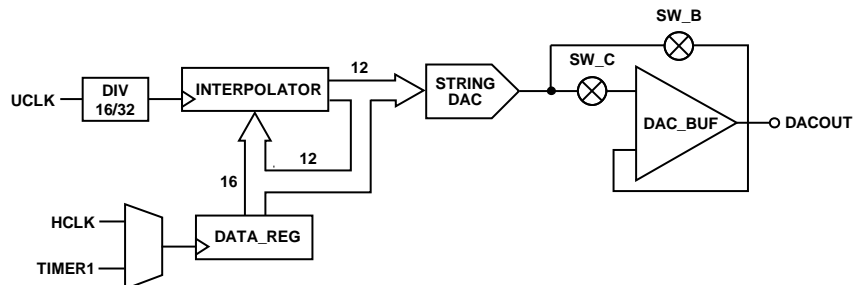

Figure 28. DAC User Functionality

ADuC7121

Table 49 DACxCON Registers (Default Value = 0x100, Read/Write Access)

Name	Address
DAC0CON	0xFFFF0580
DAC1CON	0xFFFF0588
DAC2CON	0xFFFF05B0
DAC3CON	0xFFFF05D8

Table 50. DAC0CON MMR Bit Designations

Bit	Value	Name	Description
15:9	0		Reserved.
8	1	DACPD	DAC power-down. Set by the user to set DACOUTx to tristate mode.
7	0	DACBUF_LP	DAC buffer low power mode. Set by the user to place DAC_BUFF into a low power mode.
6	0	BYP	DAC bypass bit. Set this bit to bypass the DAC buffer. Cleared to buffer the DAC output.
5	0	DACCLK	DAC update rate. Set by the user to update the DAC using Timer1. Cleared by the user to update the DAC using HCLK (core clock).
4	0	DACCLR	DAC clear bit. Set by the user to enable normal DAC operation. Cleared by the user to reset data register of the DAC to 0.
3	0	Mode	Mode bit. Set by the user to operate on DAC normal mode and turn off the interpolator clock source. Cleared by the user to enable the interpolation mode.
2	0	Rate	Rate bit. Set by the user to enable the interpolation clock to HCLK/16. Cleared by the user to HCLK/32.
1:0		DACRNx	DAC range bits. 00 DAC range is from AGND to the internal reference. 01 EXT_REF DAC range is from AGND to the external reference. See the REFCON MMR in Table 39 for details. 10 EXT_REF DAC range is from AGND to the external reference. See the REFCON MMR in Table 39 for more details. 11 AVDD and AGND.

Table 51. DACxDAT Registers (Default Value = 0x00000000, Read/Write Access)

Name	Address
DAC0DAT	0xFFFF0584
DAC1DAT	0xFFFF058C
DAC2DAT	0xFFFF05B4
DAC3DAT	0xFFFF05DC

Table 52. DACxDAT MMR Bit Designations

Bit	Description
31:28	Reserved.
27:16	12-bit data for DACx.
15:12	Extra bits for interpolation mode.
11:0	Reserved.

Using the DACs

The on-chip DAC architecture consists of a resistor string DAC followed by an output buffer amplifier. The functional equivalent is shown in Figure 29.

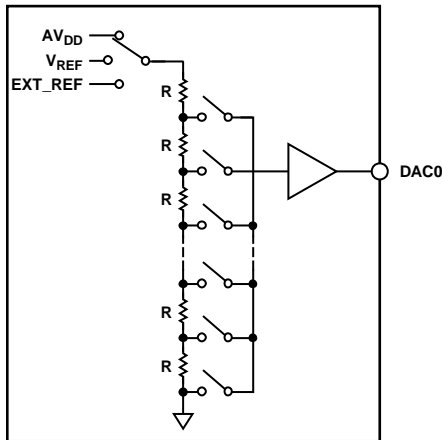

Figure 29. DAC Structure

As shown in Figure 29, the reference source for each DAC is user-selectable in software. It can be either AV_{DD} , V_{REF} , or EXT_REF . In 0 V-to- AV_{DD} mode, the DAC output transfer function spans from 0 V to the voltage at the AV_{DD} pin. In 0 V-to- EXT_REF mode, the DAC output transfer function spans from 0 V to the voltage at the $V_{REF_2.5}$ pin. In 0 V-to- V_{REF} mode, the DAC output transfer function spans from 0 V to the internal 2.5 V reference, V_{REF} .

The DAC output buffer amplifier features a true rail-to-rail output stage implementation. This means that, when unloaded, each output is capable of swinging to within less than 5 mV of both AV_{DD} and ground. Moreover, the linearity specification of the DAC (when driving a 5 k Ω resistive load to ground) is guaranteed through the full transfer function except for Code 0 to Code 100, and, in 0 V-to- AV_{DD} mode only, Code 3995 to Code 4095.

Linearity degradation near ground and AV_{DD} is caused by saturation of the output amplifier, and a general representation of its effects (neglecting offset and gain error) is shown in Figure 30. The dotted line in Figure 30 indicates the ideal transfer function, and the solid line represents what the transfer function may look like with endpoint nonlinearities due to saturation of the output amplifier. Note that Figure 30 represents a transfer function in 0 V-to- AV_{DD} mode only. In 0 V-to- V_{REF} or 0 V-to- EXT_REF modes (with $V_{REF} < AV_{DD}$ or $EXT_REF < AV_{DD}$), the lower nonlinearity is similar. However, the upper portion of the transfer function follows the ideal line right to the end (V_{REF} in this case, not AV_{DD}), showing no signs of endpoint linearity errors.

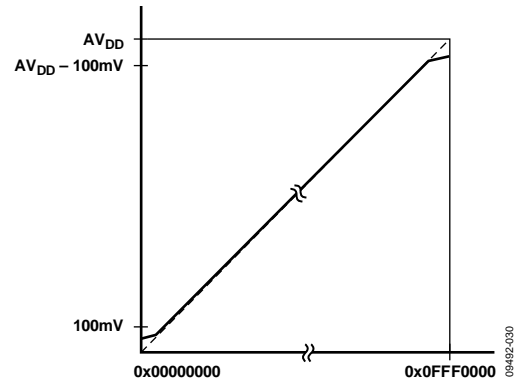

Figure 30. Endpoint Nonlinearities Due to Amplifier Saturation

The endpoint nonlinearities conceptually illustrated in Figure 30 worsen as a function of output loading. The ADuC7121 data sheet specifications assume a 5 k Ω resistive load to ground at the DAC output. As the output is forced to source or sink more current, the nonlinear regions at the top or bottom (respectively) of Figure 30 become larger. With larger current demands, this can significantly limit output voltage swing.

LDO (LOW DROPOUT REGULATOR)

The ADuC7121 contains an integrated LDO, which generates the core supply voltage (DVDD) of approximately 2.6 V from the IOVDD supply. As the LDO is driven from IOVDD, the IOVDD supply voltage needs to be greater than 2.7 V.

An external compensation capacitor (C_T) of 0.47 μ F with low ESR must be placed very close to each of the DVDD pins. This capacitor also acts as a storage tank of charge, and supplies an instantaneous charge required by the core, particularly at the positive edge of the core clock (HCLK).

The DVDD voltage generated by the LDO is solely for providing a supply for the ADuC7121. Therefore, users should not use a DVDD pin as the power supply pin for any other chip. In addition, it is recommended that the IOVDD has excellent power supply decoupling to help improve line regulation performance of the LDO.

The DVDD pin has no reverse battery, current limit, or thermal shutdown protection; therefore, it is essential that users of the ADuC7121 do not short this pin to ground at any time during normal operation or during board manufacture.

CURRENT OUTPUT DACs (IDAC)

The ADuC7121 provides five current output digital-to-analog converters (DACs). The current sources (five current DACs) feature low noise and low drift high-side current output with 11-bit resolution. The five IDACs are as follows: IDAC0 with 250 mA full-scale (FS) output, IDAC1 with 200 mA FS output, IDAC2 with 80 mA FS output, IDAC3 with 45 mA FS output, and IDAC4 with 20 mA FS output.

The reference current of each IDAC is generated by a precision internal band gap voltage reference and an external precision resistor, and as such, the gain error of each IDAC is impacted by the accuracy of the external resistor. Connect the resistor to the I_{REF} pin. The noise of each IDAC is limited by its damping capacitor, C_{DAMP} , which is selected to band limit noise as well as to meet the signal bandwidth. Connect C_{DAMP_IDACx} to PGND.

An NMOS switch is provided to shut down the IDAC0 diode. Note that the output current switches off while this switch is on. When the switch is on, the IDAC0 pin is able to withstand -0.5 V. At power-up or reset, IDAC0 is powered down by default and its output is high impedance. When enabled, the IDAC0 output current does not overshoot.

To reduce the heat dissipation on chip, a separate power supply can be used. An internal LDO provides a stable 2.5 V supply for all low current internal IDACs.

Precision Current Generation and Fault Protection

The reference current is generated either from an on-chip precision band gap voltage source or from an external voltage reference by default, which is applied to an external precision resistor. This resistor is connected to the I_{REF} pin. The band gap is factory trimmed to obtain a precise initial value and low temperature drift. The external resistor is an assumed 0.1% accuracy with 5 ppm drift, and a 0.1 μ F external capacitor is required to bypass high frequency noise.

A fault detection block is included to stop problems from occurring if too small a reference resistor is detected. By sending the developed reference current into an on-board resistor of half the expected size of the external resistor, a fault signal is generated if the resistor is less than half the expected value (to an accuracy

of about 20%). The external resistor value is calculated by $R_{EXT} = V_{REF}/I_{REF}$, where $I_{REF} = 370.37 \mu A$ and V_{REF} is the selected reference voltage for the voltage-to-current circuit.

IDAC and Output Stage Fault Protection

All five IDACs use the same architecture to generate high-side current whereby only the section that generates the reference current is shared. A low current is generated first using a current-mode DAC, which is then mirrored up to give the large output current that is desired. A thermal shutdown circuit protects the chip from overheating. The IDACs are guaranteed monotonic to within 11 bits of resolution.

The bandwidth limit is provided by a programmable internal resistor and an external capacitor. This is to filter high frequency noise. It is also used to generate a triangle wave from a square wave input for the IDAC4 only.

The thermal shutdown circuit automatically shuts down all of the output stages when the chip temperature exceeds a certain threshold. The intention of the thermal shutdown is only for protection in the case of a short on an IDAC output. The overheating of the chip from other causes also triggers a thermal shutdown but only the IDAC output stage is automatically shut down. It triggers an interrupt and sets the TSHUT bit in the IDACSTA register to indicate the overheating of the chip.

In case the digital core malfunctions at a temperature lower than the thermal shutdown trigger point, the circuit can still shut down the IDAC, but a watchdog reset must be used to reset the chip. The TSHUT bit retains its value after a software reset or a watchdog reset. This bit can only be cleared by a power-on reset, a hardware reset, or when 0 is written to the IDACSTA register.

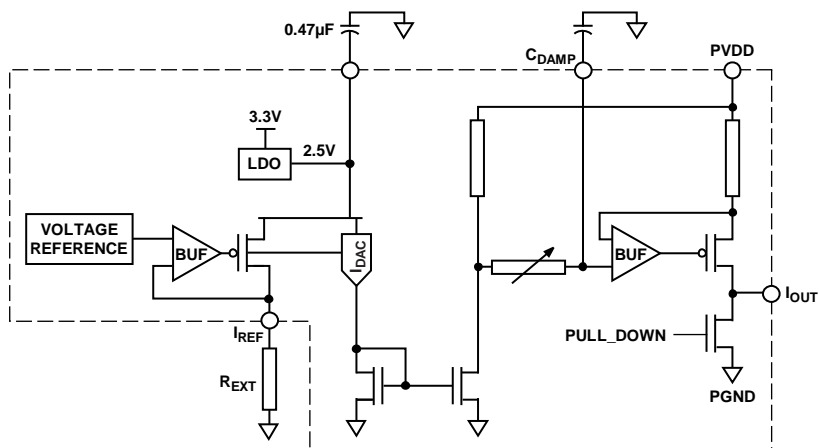

Figure 31.

IDAC MMRs

Table 53. IDAC Control Registers (Read and Write Access)

Name	Address (Hex)	Default Value
IDAC0CON	0xFFFF0700	0x0010
IDAC1CON	0xFFFF070C	0x0010
IDAC2CON	0xFFFF0718	0x0010
IDAC3CON	0xFFFF0724	0x0010
IDAC4CON	0xFFFF0730	0x0010
TDSCON	0xFFFF073C	0x00
IDAC0PULLDOWN	0xFFFF0744	0x00

Table 54. IDACxCON MMR Bit Designations

Bit	Name	Value	Description
15:9			These bits are reserved.
8:7	SFHM0DE	00 01 10 11	Bit shuffling is a method of increasing the ac precision of an IDAC. Do not use in applications where dc performance is important. Shuffle one increment at a time. Shuffle based on an internal counter. Shuffle based on the input data. Reserved.
6	MSBSHFEN	0	MSB shuffle enable. Set by the user to 1 to enable MSB shuffling. Set by the user to 0 to disable MSB shuffling.
5	LSBSHFEN	0	LSB shuffle enable. Set by the user to 1 to enable LSB shuffling. Set by the user to 0 to disable LSB shuffling.

Bit	Name	Value	Description
4	IDACPD	1	IDAC power-down bit. Set by the user to 1 to power down the IDAC. IDAC output is high impedance. Set by the user to 0 to power up the IDAC.
3	IDACCLK	0	IDAC update rate. Set by the user to update the IDAC using Timer1. Cleared by the user to update the IDAC using HCLK (core clock).
2	IDACCLR	0	IDAC clear bit. Set by the user to enable normal IDAC operation. Cleared by the user to reset data register of the IDAC to 0.
1	Mode	0	Mode bit. This bit must always be cleared.
0	Reserved	0	Set this bit to 0.

Table 55. TDSCON MMR Bit Designations

Bit	Value	Name	Description
7:3		Reserved	The user sets these bits to 0.
2	0	DISLR	Disable low external resistance bit. Set by the user to 0 to disable the output current DACs if the external resistance is lower than a trip point.
1	0	DISINT	Disable thermal trigger interrupt. Set by the user to 0 to generate an interrupt if the temperature passes the thermal shutdown point.
0	0	DISSD	Set by the user to 0 to disable the output current DACs when the temperature passes a trip point.

Table 56. IDAC0PULLDOWN MMR Bit Designations

Bit	Value	Name	Description
7:6		Reserved	These bits are set to 0 by the user.
5	0	Pulldown	IDAC0 pull-down. Set to 1 by the user to pull down the IDAC0 pin as well as power down the IDAC0. Set to 0 by the user to disable the pull-down.
4	0	PLA_PD_EN	PLA output trigger enable. Set to 1 by the user to enable the PLA output to trigger the IDAC0 pull-down. Set to 0 by the user to disable this feature.
3:0		PLA Source	PLA output source for PLA output trigger enable. Can select the output of any element, 0 to 15, by programming these bits with the corresponding binary value.

Table 57. IDAC Data Registers (Default Value = 0x00000000, Read and Write Access)

Name	Address (Hex)
IDAC0DAT	0xFFFF0704
IDAC1DAT	0xFFFF0710
IDAC2DAT	0xFFFF071C
IDAC3DAT	0xFFFF0728
IDAC4DAT	0xFFFF0734

Table 58. IDACxDAT MMR Bit Designations

Bit	Name	Value	Description
31:28	Reserved		These bits are reserved.
27:16	Data		Data from IDACx.
15:0	Reserved	000	These bits are reserved.

Table 59. IDAC Bandwidth Registers (Default Value = 0x00, Read and Write Access)

Name	Address
IDAC0BW	0xFFFF0708
IDAC1BW	0xFFFF0714
IDAC2BW	0xFFFF0720
IDAC3BW	0xFFFF072C
IDAC4BW	0xFFFF0738

Table 60. IDACxBW MMR Bit Designations

Bit	Name	Value	Description
7:4	Reserved		The user sets these bits to 0.
3:0	BW		Bandwidth control bits. Defines the 3 dB bandwidth of the RC low-pass filter, assuming a 0.01 μ F capacitor on the C _{DAMP_IDACx} pins of the IDACx.
		000	100 kHz.
		001	28.7 kHz.
		010	15 kHz.
		011	7.8 kHz.
		100	4 kHz.
		101	2.2 kHz.
		110	1.2 kHz.
		Others	Not defined.

Table 61. IDAC Status Register (Default Value = 0x00, Read and Write Access)

Name	Address (Hex)
IDACSTA	0xFFFF0740

Table 62. IDACSTA MMR Bit Designations

Bit	Value	Name	Description
7:2		Reserved	These bits are set to 0 by the user.
1	0	TSHUT	Thermal shutdown error status bit. Set to 1 by the core indicating a thermal shutdown event. Set to 0 by the core indicating the IDACs are within operating temperature.
0	0	EXTRESLOW	External resistor short bit. Set to 1 by the core indicating an external resistor short. Set to 0 by the core when operating normally.

OSCILLATOR AND PLL—POWER CONTROL

The ADuC7121 integrates a 32.768 kHz oscillator, a clock divider, and a PLL. The PLL locks onto a multiple (1275) of the internal oscillator to provide a stable 41.78 MHz clock for the system. The core can operate at this frequency, or at binary submultiples of it, to allow for power saving. The default core clock is the PLL clock divided by 8 (CD = 3) or 5.2 MHz. The core clock frequency can be output on the XCLK pin as described in Figure 32. Note that when the XCLK pin is used to output the core clock, the output signal is not buffered and is not suitable for use as a clock source to an external device without an external buffer.

A power-down mode is available on the ADuC7121.

The operating mode, clocking mode, and programmable clock divider are controlled via two MMRs, PLLCON (see Table 65) and POWCON (see Table 66). PLLCON controls the operating mode of the clock system, and POWCON controls the core clock frequency and the power-down mode.

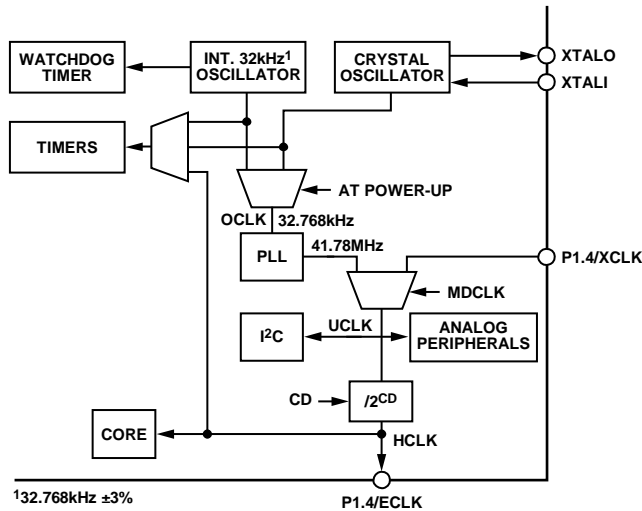

Figure 32. Clocking System

External Crystal Selection

To switch to an external crystal, use the following procedure:

1. Enable the Timer2 interrupt and configure it for a timeout period of >120 μ s.
2. Follow the write sequence to the PLLCON register, setting the MDCLK bits to 01 and clearing the OSEL bit.
3. Force the part into nap mode by writing the correct write sequence to the POWCON register.
4. When the part is interrupted from nap mode by the Timer2 interrupt source, the clock source has switched to the external clock.

In noisy environments, noise can couple to the external crystal pins, and PLL may lose lock momentarily. A PLL interrupt is provided in the interrupt controller. The core clock is immediately halted, and this interrupt is serviced only when the lock is restored.

In case of crystal loss, the watchdog timer should be used. During initialization, a test on the RSTSTA register can determine if the reset came from the watchdog timer.

Example Source Code

```
T2LD = 5;
TCN = 0x480;

while ((T2VAL == t2val_old) || (T2VAL > 3))
//ensures timer value loaded
    IRQEN = 0x10;
//enable T2 interrupt
    PLLKEY1 = 0xAA;
    PLLCON = 0x01;
    PLLKEY2 = 0x55;

    POWKEY1 = 0x01;
    POWCON = 0x27;
// set core into nap mode
    POWKEY2 = 0xF4;
```

External Clock Selection

To switch to an external clock on P1.4 (of the P1.4/PWM1/ECLK/XCLK/PLAI[8] pin), configure P1.4 in Mode 2. The external clock can be up to 41.78 MHz.

Example Source Code

```
T2LD = 5;
TCN = 0x480;

while ((T2VAL == t2val_old) || (T2VAL > 3))
//ensures timer value loaded
    IRQEN = 0x10;
//enable T2 interrupt
    PLLKEY1 = 0xAA;
    PLLCON = 0x03; //Select external clock
    PLLKEY2 = 0x55;

    POWKEY1 = 0x01;
    POWCON = 0x27; // Set Core into Nap mode
    POWKEY2 = 0xF4;
```

Power Control System

A choice of operating modes is available on the ADuC7121.

Table 63 describes what part of the ADuC7121 is powered on in the different modes and indicates the power-up time. Table 64 gives some typical values of the total current consumption (analog + digital supply currents) in the different modes, depending on the clock divider bits. The ADC is turned off. Note that these values also include current consumption of the regulator and other parts on the test board on which these values were measured.

ADuC7121

Table 63. Operating Modes

Mode	Core	Peripherals	PLL	XTAL/Timer2/Timer3	External IRQ	Start-Up/Power-On Time
Active	On	On	On	On	On	66 ms at CD = 0
Pause		On	On	On	On	24 ns at CD = 0; 3.06 μ s at CD = 7
Nap			On	On	On	24 ns at CD = 0; 3.06 μ s at CD = 7
Sleep				On	On	1.58 ms
Stop					On	1.7 ms

Table 64. Typical Current Consumption at 25°C

PC[2:0]	Mode	CD = 0	CD = 1	CD = 2	CD = 3	CD = 4	CD = 5	CD = 6	CD = 7
000	Active	33.1	21.2	13.8	10	8.1	7.2	6.7	6.45
001	Pause	22.7	13.3	8.5	6.1	4.9	4.3	4	3.85
010	Nap	3.8	3.8	3.8	3.8	3.8	3.8	3.8	3.8
011	Sleep	0.4	0.4	0.4	0.4	0.4	0.4	0.4	0.4
100	Stop	0.4	0.4	0.4	0.4	0.4	0.4	0.4	0.4

MMRs and Keys

To prevent accidental programming, a certain sequence must be followed when writing in the PLLCON and POWCON registers (see Table 67).

PLLKEYx Registers

Name: PLLKEY1
Address: 0xFFFF0410
Default value: 0x0000
Access: Write only

Name: PLLKEY2
Address: 0xFFFF0418
Default value: 0x0000
Access: Write only

PLLCON Register

Name: PLLCON
Address: 0xFFFF0414
Default value: 0x21
Access: Read and write

Table 65. PLLCON MMR Bit Designations

Bit	Value	Name	Description
7:6			Reserved.
5		OSEL	32 kHz PLL input selection. Set by the user to use the internal 32 kHz oscillator. Set by default. Cleared by the user to use the external 32 kHz crystal.
4:2			Reserved.
1:0		MDCLK	Clocking modes.
	00		Reserved.
	01		PLL. Default configuration.
	10		Reserved.
	11		External clock on the P1.4/PWM1/ECLK/XCLK/PLAI[8] pin.

POWKEYx Registers

Name: POWKEY1
Address: 0xFFFF0404
Default value: 0x0000
Access: Write only

Name: POWKEY2
Address: 0xFFFF040C
Default value: 0x0000
Access: Write only

POWCON Register

Name: POWCON
Address: 0xFFFF0408
Default value: 0x0003
Access: Read and write

Table 66. POWCON MMR Bit Designations

Bit	Value	Name	Description
7			Reserved.
6:4		PC	Operating modes.
	000		Active mode.
	001		Pause mode.
	010		Nap mode.
	011		Sleep mode. IRQ0 to IRQ3 and Timer2 can wake up the ADuC7121.
	100		Stop mode.
	Others		Reserved.
3		RSVD	Reserved.
2:0		CD	CPU clock divider bits.
	000		41.779200 MHz.
	001		20.889600 MHz.
	010		10.444800 MHz.
	011		5.222400 MHz.
	100		2.611200 MHz.
	101		1.305600 MHz.
	110		654.800 kHz.
	111		326.400 kHz.

Table 67. PLLCON and POWCON Write Sequence

PLLCON	POWCON
PLLKEY1 = 0xAA	POWKEY1 = 0x01
PLLCON = 0x01	POWCON = user value
PLLKEY2 = 0x55	POWKEY2 = 0xF4

DIGITAL PERIPHERALS

PWM GENERAL OVERVIEW

The ADuC7121 integrates a 6-channel PWM interface. The PWM outputs can be configured to drive an H-bridge or can be used as standard PWM outputs. On power-up, the PWM outputs default to H-bridge mode. This ensures that the motor is turned off by default. In standard PWM mode, the outputs are arranged as three pairs of PWM pins. Users have control over the period of each pair of outputs and over the duty cycle of each individual output.

In all modes, the PWMxCOMx MMRs control the point at which the PWM outputs change state. An example of the first pair of PWM outputs (PWM1 and PWM2) is shown in Figure 33.

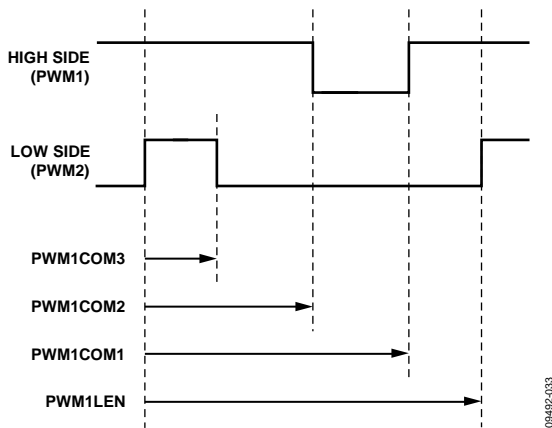

Figure 33. PWM Timing

09492-033

The PWM clock is selectable via PWMCON1 with one of the following values: UCLK divide-by-2, 4, 8, 16, 32, 64, 128, or 256. The length of a PWM period is defined by PWMxLEN.

The PWM waveforms are set by the count value of the 16-bit timer and the compare registers contents as shown with the PWM1 and PWM2 waveforms above.

The low-side waveform, PWM2, goes high when the timer count reaches PWM1LEN, and it goes low when the timer count reaches the value held in PWM1COM3 or when the high-side waveform PWM1 goes low.

The high-side waveform, PWM1, goes high when the timer count reaches the value held in PWM1COM1, and it goes low when the timer count reaches the value held in PWM1COM2.

Table 68. PWM MMRs

Name	Function
PWMCON1	PWM control
PWM1COM1	Compare Register 1 for PWM Output 1 and PWM Output 2
PWM1COM2	Compare Register 2 for PWM Output 1 and PWM Output 2
PWM1COM3	Compare Register 3 for PWM Output 1 and PWM Output 2
PWM1LEN	Frequency control for PWM Output 1 and PWM Output 2
PWM2COM1	Compare Register 1 for PWM Output 3 and PWM Output 4
PWM2COM2	Compare Register 2 for PWM Output 3 and PWM Output 4
PWM2COM3	Compare Register 3 for PWM Output 3 and PWM Output 4
PWM2LEN	Frequency control for PWM Output 3 and PWM Output 4
PWM3COM1	Compare Register 1 for PWM Output 5 and PWM Output 6
PWM3COM2	Compare Register 2 for PWM Output 5 and PWM Output 6
PWM3COM3	Compare Register 3 for PWM Output 5 and PWM Output 6
PWM3LEN	Frequency control for PWM Output 5 and PWM Output 6
PWMCON2	PWM convert start control
PWMICLR	PWM interrupt clear

Table 69. PWMCON1 MMR Bit Designations (Address = 0xFFFF0F80, Default Value = 0x0012)

Bit	Name	Description
15	Reserved	This bit is reserved.
14	SYNC	Enables PWM synchronization. Set to 1 by the user so that all PWM counters are reset on the next clock edge after the detection of a high-to-low transition on SYNC of the P0.3/MISO/PLAO[12]/SYNC pin. Cleared by the user to ignore transitions on SYNC of the P0.3/MISO/PLAO[12]/SYNC pin.
13	PWM6INV	Set to 1 by the user to invert PWM6. Cleared by the user to use PWM6 in normal mode.
12	PWM4INV	Set to 1 by the user to invert PWM4. Cleared by the user to use PWM4 in normal mode.
11	PWM2INV	Set to 1 by the user to invert PWM2. Cleared by the user to use PWM2 in normal mode.
10	PWMTRIP	Set to 1 by the user to enable PWM trip interrupt. When the PWMTRIP input is low, the PWMEN bit is cleared and an interrupt is generated. Cleared by the user to disable the PWMTRIP interrupt.
9	ENA	If HOFF = 0 and HMODE = 1. If HOFF = 1 and HMODE = 1, see Table 70. If not in H-Bridge mode, this bit has no effect. Set to 1 by the user to enable PWM outputs. Cleared by the user to disable PWM outputs.
8:6	PWMCP[2:0]	PWM clock prescaler bits. Sets the UCLK divider. 000 = UCLK divide-by-2. 001 = UCLK divide-by-4. 010 = UCLK divide-by-8. 011 = UCLK divide-by-16. 100 = UCLK divide-by-32. 101 = UCLK divide-by-64. 110 = UCLK divide-by-128. 111 = UCLK divide-by-256.
5	POINV	Set to 1 by the user to invert all PWM outputs. Cleared by the user to use PWM outputs as normal.
4	HOFF	High-side off. Set to 1 by the user to force PWM1 and PWM3 outputs high. This also forces PWM2 and PWM4 low. Cleared by the user to use the PWM outputs as normal.
3	LCOMP	Load compare registers. Set to 1 by the user to load the internal compare registers with the values in PWMxCOMx on the next transition of the PWM timer from 0x00 to 0x01. Cleared by the user to use the values previously stored in the internal compare registers.
2	DIR	Direction control. Set to 1 by the user to enable PWM1 and PWM2 as the output signals while PWM3 and PWM4 are held low. Cleared by the user to enable PWM3 and PWM4 as the output signals while PWM1 and PWM2 are held low.
1	HMODE	Enables H-bridge mode. Set to 1 by the user to enable H-Bridge mode and Bits[5:2] of PWMCON1. Cleared by the user to operate the PWMs in standard mode.
0	PWMEN	Set to 1 by the user to enable all PWM outputs. Cleared by the user to disable all PWM outputs.

ADuC7121

In H-bridge mode, HMODE = 1 and Table 69 determine the PWM outputs, as listed in Table 70.

Table 70. PWM Output Selection

PWMCOM1 MMR				PWM Outputs			
ENA	HOFF	POINV	DIR	PWM1	PWM2	PWMR3	PWM4
0	0	X ¹	X ¹	1	1	1	1
X ¹	1	X ¹	X ¹	1	0	1	0
1	0	0	0	0	0	HS ¹	LS ¹
1	0	0	1	HS ¹	LS ¹	0	0
1	0	1	0	HS ¹	LS ¹	1	1
1	0	1	1	1	1	HS ¹	LS ¹

¹ HS is high side, LS is low side, X is a don't care bit.

On power-up, PWMCON1 defaults to 0x12 (HOFF = 1 and HMODE = 1). All GPIO pins associated with the PWM are configured in PWM mode by default (see Table 71).

Table 71. Compare Register (Default Value = 0x0000, Access is Read/Write)

Name	Address	Default Value	Access
PWM1COM1	0xFFFF0F84	0x0000	R/W
PWM1COM2	0xFFFF0F88	0x0000	R/W
PWM1COM3	0xFFFF0F8C	0x0000	R/W
PWM2COM1	0xFFFF0F94	0x0000	R/W
PWM2COM2	0xFFFF0F98	0x0000	R/W
PWM2COM3	0xFFFF0F9C	0x0000	R/W
PWM3COM1	0xFFFF0FA4	0x0000	R/W
PWM3COM2	0xFFFF0FA8	0x0000	R/W
PWM3COM3	0xFFFF0FAC	0x0000	R/W

The PWM trip interrupt can be cleared by writing any value to the PWMICLR MMR. Note that when using the PWM trip interrupt, users should make sure that the PWM interrupt has been cleared before exiting the ISR. This prevents generation of multiple interrupts.

PWM CONVERT START CONTROL

The PWM can be configured to generate an ADC convert start signal after the active low side signal goes high. There is a programmable delay between when the low-side signal goes high and the convert start signal is generated.

This is controlled via the PWMCON2 MMR. If the delay selected is higher than the width of the PWM pulse, the interrupt remains low.

Table 72. PWMCON2 MMR Bit Designations (Address = 0xFFFF0FB4, Default Value = 0x00)

Bit	Name	Value	Description
7	CSEN		Set to 1 by the user to enable the PWM to generate a convert start signal. Cleared by the user to disable the PWM convert start signal.
3:0	CSD3 to CSD0		Convert start delay. Delays the convert start signal by a number of clock pulses.
		0000	4 clock pulses.
		0001	8 clock pulses.
		0010	12 clock pulses.
		0011	16 clock pulses.
		0100	20 clock pulses.
		0101	24 clock pulses.
		0110	28 clock pulses.
		0111	32 clock pulses.
		1000	36 clock pulses.
		1001	40 clock pulses.
		1010	44 clock pulses.
		1011	48 clock pulses.
		1100	52 clock pulses.
		1101	56 clock pulses.
		1110	60 clock pulses.
		1111	64 clock pulses.

When calculating the time from the convert start delay to the start of an ADC conversion, the user needs to take account of internal delays. The following example shows the case for a delay of four clocks. One additional clock is required to pass the convert start signal to the ADC logic. When the ADC logic receives the convert start signal, an ADC conversion begins on the next ADC clock edge (see Figure 34).

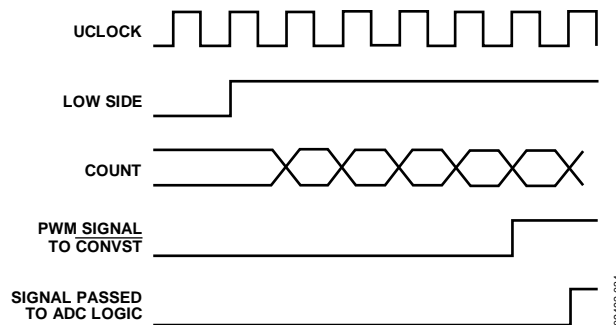

Figure 34. ADC Conversion

09492-034

GENERAL-PURPOSE INPUT/OUTPUT

The ADuC7121 provides 32 general-purpose, bidirectional input/output (GPIO) pins. All I/O pins are 5 V tolerant, meaning that the GPIOs support an input voltage of 5 V. In general, many of the GPIO pins have multiple functions (see Table 73). By default, the GPIO pins are configured in GPIO mode.

All GPIO pins have an internal pull-up resistor (of about 100 k Ω) and their drive capability is 1.6 mA. Note that a maximum of 20 GPIOs can drive 1.6 mA at the same time. The 32 GPIOs are grouped into four ports: Port 0 to Port 3. Each port is controlled by four or five MMRs, with x representing the port number.

GPxCON Registers

Name: GP0CON
 Address: 0xFFFF0D00
 Default value: 0x11000000
 Access: Read and write

Name: GP1CON
 Address: 0xFFFF0D04
 Default value: 0x00000000
 Access: Read and write

Name: GP2CON
 Address: 0xFFFF0D08
 Default value: 0x00000000
 Access: Read and write

Name: GP3CON
 Address: 0xFFFF0D0C
 Default value: 0x00000000
 Access: Read and write

The input level of any GPIO can be read at any time in the GPxDAT MMR, even when the pin is configured in a mode other than GPIO. The PLA input is always active.

When the ADuC7121 device enters a power-saving mode, the GPIO pins retain their state.

GPxCON is the Port x control register, and it selects the function of each pin of Port x, as described in Table 73.

ADuC7121

Table 73. GPIO Pin Function Designations

Port	Pin	Configuration (See GPxCON Table 74)			
		00	01	10	11
0	P0.0	GPIO	SCL0	JTAG disabled JTAG disabled ADC _{BUSY} SYNC (PWM) TRIP (PWM) ADC _{CONVST}	PLAI[5]
	P0.1	GPIO	SDA0		PLAI[4]
	P0.2	GPIO	SPICLK		PLAO[13]
	P0.3	GPIO	MISO		PLAO[12]
	P0.4	GPIO	MOSI		PLAI[11]
	P0.5	GPIO	\overline{CS}		PLAI[10]
	P0.6	GPIO	\overline{MRST}		PLAI[2]
	P0.7	GPIO	\overline{TRST}		PLAI[3]
1	P1.0	GPIO	SIN	SCL1 SDA1	PLAI[7]
	P1.1	GPIO	SOUT		PLAI[6]
	P1.2 ¹	TDI (JTAG)	PWM1 PWM2		PLAO[15]
	P1.3 ¹	TDO (JTAG)			PLAO[14]
	P1.4	GPIO	ECLK/XCLK	PLAI[8]	
	P1.5	GPIO		PLAI[9]	
	P1.6	GPIO		PLAO[5]	
	P1.7	GPIO		PLAO[4]	
2	P2.0	GPIO/IRQ0	PWM5 PWM6		PLAI[13]
	P2.1	GPIO/IRQ1			PLAI[12]
	P2.2	GPIO			PLAI[1]
	P2.3	GPIO/IRQ2			PLAI[14]
	P2.4	GPIO			PLAO[7]
	P2.5	GPIO			PLAO[6]
	P2.6	GPIO/IRQ3			PLAI[15]
	P2.7	GPIO			PLAI[0]
3	P3.0	GPIO	PWM3 PWM4		PLAO[0]
	P3.1	GPIO			PLAO[1]
	P3.2	GPIO/IRQ4			PLAO[2]
	P3.3	GPIO/IRQ5			PLAO[3]
	P3.4	GPIO			PLAO[8]
	P3.5	GPIO			PLAO[9]
	P3.6	GPIO			PLAO[10]
	P3.7	GPIO/ \overline{BM}			PLAO[11]

¹ Reconfiguring these pins disables JTAG mode. Erase part to reenale JTAG access after changing default value.

Table 74. GPxCON MMR Bit Designations

Bit	Description
31:30	Reserved
29:28	Select function of the Px.7 pin
27:26	Reserved
25:24	Select function of the Px.6 pin
23:22	Reserved
21:20	Select function of the Px.5 pin
19:18	Reserved
17:16	Select function of the Px.4 pin
15:14	Reserved
13:12	Select function of the Px.3 pin
11:10	Reserved
9:8	Select function of the Px.2 pin
7:6	Reserved
5:4	Select function of the Px.1 pin
3:2	Reserved
1:0	Select function of the Px.0 pin

GPxPAR Registers

The GPxPAR registers program the parameters for Port 0, Port 1, Port 2, and Port 3. Note that the GPxDAT MMR must always be written after changing the GPxPAR MMR.

Name: GP0PAR
 Address: 0xFFFF0D2C
 Default value: 0x20000000
 Access: Read and write

Name: GP1PAR
 Address: 0xFFFF0D3C
 Default value: 0x00000000
 Access: Read and write

Name: GP2PAR
 Address: 0xFFFF0D4C
 Default value: 0x00000000
 Access: Read and write

Name: GP3PAR
 Address: 0xFFFF0D5C
 Default value: 0x00222222
 Access: Read and write

Table 75. GPxPAR MMR Bit Designations

Bit	Description
31:29	Reserved
28	Pull-up disable Px.7 pin Set to 1 to enable the pull-up Clear to 0 to disable the pull-up
27:25	Reserved
24	Pull-up disable Px.6 pin
23:21	Reserved
20	Pull-up disable Px.5 pin
19:17	Reserved
16	Pull-up disable Px.4 pin
15:13	Reserved
12	Pull-up disable Px.3 pin
11:9	Reserved
8	Pull-up disable Px.2 pin
7:5	Reserved
4	Pull-up disable Px.1 pin
3:1	Reserved
0	Pull-up disable Px.0 pin

GPxDAT Register

GPxDAT is a Port x configuration and data register. It configures the direction of the GPIO pins of Port x, sets the output value for the pins configured as output, and receives and stores the input value of the pins configured as inputs.

Name: GP0DAT
 Address: 0xFFFF0D20
 Default value: 0x000000XX
 Access: Read and write

Name: GP1DAT
 Address: 0xFFFF0D30
 Default value: 0x000000XX
 Access: Read and write

Name: GP2DAT
 Address: 0xFFFF0D40
 Default value: 0x000000XX
 Access: Read and write

ADuC7121

Name: GP3DAT
Address: 0xFFFF0D50
Default value: 0x000000XX
Access: Read and write

Table 76. GPxDAT MMR Bit Designations

Bit	Description
31:24	Direction of the data. Set to 1 by the user to configure the GPIO pin as an output. Cleared to 0 by the user to configure the GPIO pin as an input.
23:16	Port x data output.
15:8	Reflect the state of Port x pins at reset (read only).
7:0	Port x data input (read only).

GPxSET Registers

The GPxSET registers provide a data set for the Port x registers.

Name: GP0SET
Address: 0xFFFF0D24
Default value: 0x000000XX
Access: Write only

Name: GP1SET
Address: 0xFFFF0D34
Default value: 0x000000XX
Access: Write only

Name: GP2SET
Address: 0xFFFF0D44
Default value: 0x000000XX
Access: Write only

Name: GP3SET
Address: 0xFFFF0D54
Default value: 0x000000XX
Access: Write only

Table 77. GPxSET MMR Bit Designations

Bit	Description
31:24	Reserved.
23:16	Data Port x set bit. Set to 1 by the user to set the bit on Port x; also sets the corresponding bit in the GPxDAT MMR. Cleared to 0 by user; does not affect the data out.
15:0	Reserved.

GPxCLR Registers

The GPxCLR registers are data clear for Port x registers.

Name: GP0CLR
Address: 0xFFFF0D28
Default value: 0x000000XX
Access: Write only

Name: GP1CLR
Address: 0xFFFF0D38
Default value: 0x000000XX
Access: Write only

Name: GP2CLR
Address: 0xFFFF0D48
Default value: 0x000000XX
Access: Write only

Name: GP3CLR
Address: 0xFFFF0D58
Default value: 0x000000XX
Access: Write only

Table 78. GPxCLR MMR Bit Designations

Bit	Description
31:24	Reserved.
23:16	Data Port x clear bit. Set to 1 by the user to clear bit on Port x; also clears the corresponding bit in the GPxDAT MMR. Cleared to 0 by user; does not affect the data output.
15:0	Reserved.

GPxOCE Registers

Open-collector functionality is available on the following GPIO pins: P1.7, P1.6, Port 2, and Port 3.

Table 79. GPxOCE MMR Bit Designations

Bit	Description
31:8	Reserved.
7	GPIO Px.7 open collector enable. Set to 1 by the user to enable the open collector. Set to 0 by the user to disable the open collector.
6	GPIO Px.6 open collector enable. Set to 1 by the user to enable the open collector. Set to 0 by the user to disable the open collector.
5	GPIO Px.5 open collector enable. Set to 1 by the user to enable open collector. Set to 0 by the user to disable the open collector.
4	GPIO Px.4 open collector enable. Set to 1 by the user to enable open collector. Set to 0 by the user to disable the open collector.
3	GPIO Px.3 open collector enable. Set to 1 by the user to enable open collector. Set to 0 by the user to disable the open collector.
2	GPIO Px.2 open collector enable. Set to 1 by the user to enable open collector. Set to 0 by the user to disable the open collector.
1	GPIO Px.1 open collector enable. Set to 1 by the user to enable open collector. Set to 0 by the user to disable the open collector.
0	GPIO Px.0 open collector enable. Set to 1 by the user to enable open collector. Set to 0 by the user to disable the open collector.

UART SERIAL INTERFACE

The ADuC7121 features a 16,450-compatible UART. The UART is a full-duplex, universal, asynchronous receiver/transmitter. A UART performs serial-to-parallel conversion on data characters received from a peripheral device, and parallel-to-serial conversion on data characters received from the ARM7TDMI. The UART features a fractional divider that facilitates high accuracy baud rate generation. The UART functionality is available on the P1.0/SIN/SCL1/PLAI[7] and P1.1/SOUT/SDA1/PLAI[6] pins of the ADuC7121.

The serial communication adopts an asynchronous protocol that supports various word length, stop bits, and parity generation options selectable in the configuration register.

BAUD RATE GENERATION

The ADuC7121 features two methods of generating the UART baud rate: normal 450 UART baud rate generation and ADuC7121 fractional divider.

Normal 450 UART Baud Rate Generation

The baud rate is a divided version of the core clock using the value in COMDIV0 and COMDIV1 MMRs (16-bit value, DL). The standard baud rate generator formula is

$$Baud\ rate = \frac{41.78\ MHz}{16 \times 2 \times DL} \quad (1)$$

Table 80 lists common baud rate values.

Table 80. Baud Rate Using the Standard Baud Rate Generator

Baud Rate	DL	Actual Baud Rate	% Error
9600	0x88	9600	0%
19,200	0x44	19,200	0%
115,200	0x0B	118,691	3%

Fractional Divider

The fractional divider combined with the normal baud rate generator allows the generating of a wider range of more accurate baud rates.

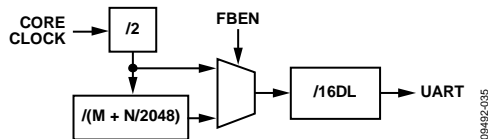

Figure 35. Baud Rate Generation Options

Calculation of the baud rate using fractional divider is as follows:

$$Baud\ Rate = \frac{41.78\ MHz}{16 \times DL \times 2 \times (M + \frac{N}{2048})}$$

$$M + \frac{N}{2048} = \frac{41.78\ MHz}{Baud\ Rate \times 16 \times DL \times 2}$$

For example, generation of 19,200 baud

$$M + \frac{N}{2048} = \frac{41.78\ MHz}{19200 \times 16 \times 67 \times 2}$$

$$M + \frac{N}{2048} = 1.015$$

where:

$$M = 1$$

$$N = 0.015 \times 2048 = 30$$

$$Baud\ Rate = \frac{41.78\ MHz}{16 \times 67 \times 2 \times (1 + \frac{30}{2048})}$$

where *Baud Rate* = 19,219 bps.

UART REGISTER DEFINITION

The UART interface consists of the following ten registers:

- COMTX: 8-bit transmit register
- COMRX: 8-bit receive register
- COMDIV0: divisor latch (low byte)
- COMDIV1: divisor latch (high byte)
- COMCON0: line control register
- COMCON1: line control register
- COMSTA0: line status register
- COMIEN0: interrupt enable register
- COMIID0: interrupt identification register
- COMDIV2: 16-bit fractional baud divide register

COMTX, COMRX, and COMDIV0 share the same address location. COMTX and COMRX can be accessed when Bit 7 in the COMCON0 register is cleared. COMDIV0 can be accessed when Bit 7 of COMCON0 is set.

UART TX Register

Write to this 8-bit register to transmit data using the UART.

Name: COMTX
Address: 0xFFFF0800
Access: Write only

UART RX Register

This 8-bit register is read from to receive data transmitted using the UART.

Name: COMRX
Address: 0xFFFF0800
Default value: 0x00
Access: Read only

UART Divisor Latch Register 0

This 8-bit register contains the least significant byte of the divisor latch that controls the baud rate at which the UART operates.

Name: COMDIV0
Address: 0xFFFF0800
Default value: 0x00
Access: Read and write

UART Divisor Latch Register 1

This 8-bit register contains the most significant byte of the divisor latch that controls the baud rate at which the UART operates.

Name: COMDIV1
Address: 0xFFFF0804
Default value: 0x00
Access: Read and write

UART Control Register 0

This 8-bit register controls the operation of the UART in conjunction with COMCON1.

Name: COMCON0
Address: 0xFFFF080C
Default value: 0x00
Access: Read and write

Table 81. COMCON0 MMR Bit Designations

Bit	Name	Description
7	DLAB	Divisor latch access. Set by the user to enable access to COMDIV0 and COMDIV1 registers. Cleared by the user to disable access to COMDIV0 and COMDIV1 and enable access to COMRX, COMTX, and COMIEN0.
6	BRK	Set break. Set by the user to force the transmit pin (SOUT) to 0. Cleared to operate in normal mode.
5	SP	Stick parity. Set by the user to force parity to defined values. 1 if EPS = 1 and PEN = 1. 0 if EPS = 0 and PEN = 1.
4	EPS	Even parity select bit. Set for even parity. Cleared for odd parity.
3	PEN	Parity enable bit. Set by the user to transmit and check the parity bit. Cleared by the user for no parity transmission or checking.
2	STOP	Stop bit. Set by the user to transmit 1.5 stop bits if the word length is five bits, or two stop bits if the word length is six, seven, or eight bits. The receiver checks the first stop bit only, regardless of the number of stop bits selected. Cleared by the user to generate one stop bit in the transmitted data.
1 to 0	WLS	Word length select. 00 = five bits. 01 = six bits. 10 = seven bits. 11 = eight bits.

UART Control Register 1

This 8-bit register controls the operation of the UART in conjunction with COMCON0.

Name: COMCON1
Address: 0xFFFF0810
Default value: 0x00
Access: Read and write

Table 82. COMCON1 MMR Bit Designations

Bit	Name	Description
7:5		Reserved bits. Not used.
4	LOOPBACK	Loopback. Set by the user to enable loopback mode. In loopback mode, SOUT is forced high.
3:2		Reserved bits. Not used.
1	RTS	Request to send. Set by the user to force the RTS output to 0. Cleared by the user to force the RTS output to 1.
0	DTR	Data terminal ready. Set by the user to force the DTR output to 0. Cleared by the user to force the DTR output to 1.

UART Status Register 0

Name: COMSTA0

Address: 0xFFFF0814

Default value: 0x60

Access: Read only

Function: This 8-bit read-only register reflects the current status on the UART.

Table 83. COMSTA0 MMR Bit Designations

Bit	Name	Description
7		Reserved.
6	TEMT	COMTX and shift register empty status bit. Set automatically if COMTX and the shift register are empty. This bit indicates that the data has been transmitted, that is, no more data is present in the shift register. Cleared automatically when writing to COMTX.
5	THRE	COMTX empty status bit. Set automatically if COMTX is empty. COMTX can be written as soon as this bit is set; the previous data might not have been transmitted yet and can still be present in the shift register. Cleared automatically when writing to COMTX.
4	BI	Break indicator. Set when SIN of the P1.0/SIN/SCL1/PLAI[7] pin is held low for more than the maximum word length. Cleared automatically.
3	FE	Framing error. Set when the stop bit is invalid. Cleared automatically.
2	PE	Parity error. Set when a parity error occurs. Cleared automatically.
1	OE	Overrun error. Set automatically if data are overwritten before being read. Cleared automatically.
0	DR	Data ready. Set automatically when COMRX is full. Cleared by reading COMRX.

ADuC7121

UART Interrupt Enable Register 0

This 8-bit register enables and disables the individual UART interrupt sources.

Name: COMIEN0
 Address: 0xFFFF0804
 Default value: 0x00
 Access: Read and write

Table 84. COMIEN0 MMR Bit Designations

Bit	Name	Description
7 to 3		Reserved. Not used. Cleared by the user.
2	ELSI	Receive pin (SIN) status interrupt enable bit. Set by the user to enable generation of an interrupt if any of the COMSTA0[3:1] register bits are set. Cleared by the user.
1	ETBEI	Enable transmit buffer empty interrupt. Set by the user to enable an interrupt when the buffer is empty during a transmission, that is, when COMSTA[5] is set. Cleared by the user.
0	ERBFI	Enable receive buffer full interrupt. Set by the user to enable an interrupt when the buffer is full during a reception. Cleared by the user.

UART Interrupt Identification Register 0

This 8-bit register reflects the source of the UART interrupt.

Name: COMIID0
 Address: 0xFFFF0808
 Default value: 0x01
 Access: Read only

Table 85. COMIID0 MMR Bit Designations

Bits[2:1] Status Bits	Bit 0 NINT	Priority	Definition	Clearing Operation
00	1		No interrupt	
11	0	1	Receive line status interrupt	Read COMSTA0
10	0	2	Receive buffer full interrupt	Read COMRX
01	0	3	Transmit buffer empty interrupt	Write data to COMTX or read COMIID0
00	0	4	Modem status interrupt	Read COMSTA1 register

UART Fractional Divider Register

This 16-bit register controls the operation of the fractional divider for the ADuC7121.

Name: COMDIV2
 Address: 0xFFFF082C
 Default value: 0x0000
 Access: Read and write

Table 86. COMDIV2 MMR Bit Designations

Bit	Name	Description
15	FBEN	Fractional baud rate generator enable bit. Set by the user to enable the fractional baud rate generator. Cleared by the user to generate the baud rate using the standard 450 UART baud rate generator.
14:13		Reserved.
12:11	FBM[1:0]	M. If FBM = 0, M = 4. See Equation 2 for the calculation of the baud rate using a fractional divider and Table 80 for common baud rate values.
10:0	FBN[10:0]	N. See Equation 2 for the calculation of the baud rate using a fractional divider and Table 80 for common baud rate values.

I²C PERIPHERALS

The ADuC7121 incorporates two I²C peripherals that may be configured as a fully I²C-compatible bus master device or as a fully I²C-compatible bus slave device. Both peripherals are identical.

The two pins used for data transfer, SDA and SCL, are configured in a wired-AND format that allows arbitration in a multimaster system. These pins require external pull-up resistors. Typical pull-up values are between 4.7 kΩ and 10 kΩ.

The address of the I²C bus peripheral in the I²C bus system is programmed by the user. This ID can be modified any time a transfer is not in progress. The user can configure the interface to respond to four slave addresses.

The transfer sequence of an I²C system consists of a master device initiating a transfer by generating a start condition while the bus is idle. The master transmits the slave device address and the direction of the data transfer (R/W) during the initial address transfer. If the master does not lose arbitration and the slave acknowledges, the data transfer is initiated. This continues until the master issues a stop condition and the bus becomes idle.

The I²C peripheral can only be configured as a master or slave at any given time. The same I²C channel cannot simultaneously support master and slave modes. The I²C interface on the ADuC7121 includes the following features:

- Support for repeated start conditions. In master mode, the ADuC7121 can be programmed to generate a repeated start. In slave mode, the ADuC7121 recognizes repeated start conditions.
- In master and slave modes, the device recognizes both 7-bit and 10-bit bus addresses.
- In I²C Master mode, the ADuC7121 supports continuous reads from a single slave up to 512 bytes in a single transfer sequence.
- Clock stretching is supported in both master and slave modes.
- In slave mode, the ADuC7121 can be programmed to return a no acknowledge. This allows the validation of checksum bytes at the end of I²C transfers.
- Bus arbitration in master mode is supported.
- Internal and external loopback modes are supported for I²C hardware testing in loopback mode.
- The transmit and receive circuits in both master and slave mode contain 2-byte FIFOs. Status bits are available to the user to control these FIFOs.

Configuring External Pins for I²C Functionality

The I²C pins of the ADuC7121 device are P0.0 and P0.1 for I²C0, and P1.0 and P1.1 for I²C1. P0.0 and P1.0 are the I²C clock signals, and P0.1 and P1.1 are the I²C data signals. For instance, to configure the I²C0 pins (SCL0, SDA0), Bit 0 and Bit 4 of the GP0CON register must be set to 1 to enable I²C mode. To configure the I²C1 pins (SCL1, SDA1), Bit 1 and Bit 5 of the

GP1CON register must be set to 1 to enable I²C mode, as shown in the

General-Purpose Input/Output section.

SERIAL CLOCK GENERATION

The I²C master in the system generates the serial clock for a transfer. The master channel can be configured to operate in fast mode (400 kHz) or standard mode (100 kHz). The bit rate is defined in the I2CDIV MMR as follows:

$$f_{SERIAL\ CLOCK} = \frac{f_{UCLK}}{(2 + DIVH) + (2 + DIVL)}$$

where:

f_{UCLK} = clock before the clock divider.

$DIVH$ = the high period of the clock.

$DIVL$ = the low period of the clock.

Thus, for 100 kHz operation

$$DIVH = DIVL = 0xCF$$

and for 400 kHz

$$DIVH = 0x28, DIVL = 0x3C$$

The I2CDIV register corresponds to DIVH:DIVL.

I²C BUS ADDRESSES

Slave Mode

In slave mode, the registers I2CxID0, I2CxID1, I2CxID2, and I2CxID3 contain the device IDs. The device compares the four I2CxIDx registers to the address byte received from the bus master. To be correctly addressed, the 7 MSBs of either ID register must be identical to that of the 7 MSBs of the first received address byte. The LSB of the ID registers (the transfer direction bit) is ignored in the process of address recognition.

The ADuC7121 also supports 10-bit addressing mode. When Bit 1 of I2CxSCON (ADR10EN bit) is set to 1, then one 10-bit address is supported in slave mode and is stored in registers I2CxID0 and I2CxID1. The 10-bit address is derived as follows:

I2CxID0[0] is the read/write bit and is not part of the I²C address.

- I2CxID0[7:1] = Address Bits[6:0].
- I2CxID1[2:0] = Address Bits[9:7].
- I2CxID1[7:3] must be set to 11110b.

Master Mode

In master mode, the I2CxADR0 register is programmed with the I²C address of the device.

In 7-bit address mode, I2CxADR0[7:1] are set to the device address. I2CxADR0[0] is the read/write bit.

In 10-bit address mode, the 10-bit address is created as follows:

- I2CxADR0[7:3] must be set to 11110b.
- I2CxADR0[2:1] = Address Bits[9:8].
- I2CxADR1[7:0] = Address Bits[7:0].

- I2CxADR0[0] is the read/write bit.

I²C REGISTERS

The I²C peripheral interfaces consists of a number of MMRs. These are described in the following section.

I²C Master Registers

I²C Master Control Register

This 16-bit MMR configures I²C peripheral in master mode.

Name: I2C0MCTL, I2C1MCTL

Address: 0xFFFFF0880, 0xFFFFF0900

Default value: 0x0000, 0x0000

Access: Read/write

Table 87. I2CxMCTL MMR Bit Designations

Bit	Name	Description
15:9		Reserved. These bits are reserved; do not write to these bits.
8	I2CMCENI	I ² C transmission complete interrupt enable bit. Set this bit to enable an interrupt on detecting a stop condition on the I ² C bus. Clear this interrupt source.
7	I2CNACKENI	I ² C no acknowledge received interrupt enable bit. Set this bit to enable interrupts when the I ² C master receives a no acknowledge. Clear this interrupt source.
6	I2CALENI	I ² C arbitration lost interrupt enable bit. Set this bit to enable interrupts when the I ² C master has been unsuccessful in gaining control of the I ² C bus. Clear this interrupt source.
5	I2CMTENI	I ² C transmit interrupt enable bit. Set this bit to enable interrupts when the I ² C master has transmitted a byte. Clear this interrupt source.
4	I2CMRENI	I ² C receive interrupt enable bit. Set this bit to enable interrupts when the I ² C master receives data. Cleared by the user to disable interrupts when the I ² C master is receiving data.
3	I2CMSEN	I ² C master SCL stretch enable bit. Set this bit to 1 to enable clock stretching. When SCL is low, setting this bit forces the device to hold SCL low until I2CMSEN is cleared. If SCL is high, setting this bit forces the device to hold SCL low after the next falling edge. Clear this bit to disable clock stretching.
2	I2CILEN	I ² C internal loopback enable. Set this bit to enable loopback test mode. In this mode, the SCL and SDA signals are connected internally to their respective input signals. Cleared by the user to disable loopback mode.
1	I2CBD	I ² C master back off disable bit. Set this bit to allow the device to compete for control of the bus even if another device is currently driving a start condition. Clear this bit to back off until the I ² C bus becomes free.
0	I2CMEN	I ² C master enable bit. Set by the user to enable I ² C master mode. Clear this bit to disable I ² C master mode.

I²C Master Status Register

This 16-bit MMR is I²C status register in master mode.

Name: I2C0MSTA, I2C1MSTA

Address: 0xFFFFF0884, 0xFFFFF0904

Default value: 0x0000, 0x0000

Access: Read only

Table 88 I2CxMSTA MMR Bit Designations

Bit	Name	Description
15:11		Reserved. These bits are reserved.
10	I2CBBUSY	I ² C bus busy status bit. This bit is set to 1 when a start condition is detected on the I ² C bus. This bit is cleared when a stop condition is detected on the bus.
9	I2CMRxFO	Master receiver (Rx) FIFO overflow. This bit is set to 1 when a byte is written to the Rx FIFO when it is already full. This bit is cleared in all other conditions.
8	I2CMTC	I ² C transmission complete status bit. This bit is set to 1 when a transmission is complete between the master and the slave with which it was communicating. If the I2CMCENI bit in I2CxMCTL is set, an interrupt is generated when the I2CMTC bit is set. Clear this interrupt source.
7	I2CMNA	I ² C master no acknowledge data bit. This bit is set to 1 when a no acknowledge condition is received by the master in response to a data write transfer. If the I2CNACKENI bit in I2CxMCTL is set, an interrupt is generated when the I2CMNA bit is set. This bit is cleared in all other conditions.
6	I2CMBUSY	I ² C master busy status bit. Set to 1 when the master is busy processing a transaction. Cleared if the master is ready or if another master device has control of the bus.
5	I2CAL	I ² C arbitration lost status bit. This bit is set to 1 when the I ² C master is unsuccessful in gaining control of the I ² C bus. If the I2CALENI bit in I2CxMCTL is set, an interrupt is generated when the I2CAL bit is set. This bit is cleared in all other conditions.
4	I2CMNA	I ² C master no acknowledge address bit. This bit is set to 1 when a no acknowledge condition is received by the master in response to an address. If the I2CNACKENI bit in I2CxMCTL is set, an interrupt is generated when the I2CMNA bit is set. This bit is cleared in all other conditions.
3	I2CMRXQ	I ² C master receive request bit. This bit is set to 1 when data enters the Rx FIFO. If the I2CMRENI in I2CxMCTL is set, an interrupt is generated. This bit is cleared in all other conditions.
2	I2CMTXQ	I ² C master transmit request bit. This bit goes high if the transmitter (Tx) FIFO is empty or only contains one byte and the master has transmitted an address + write. If the I2CMTENI bit in I2CxMCTL is set, an interrupt is generated when the I2CMTXQ bit is set. This bit is cleared in all other conditions.
1:0	I2CMTFSTA	I ² C master Tx FIFO status bits. 00 = I ² C master Tx FIFO empty. 01 = one byte in master Tx FIFO. 10 = one byte in master Tx FIFO. 11 = I ² C master Tx FIFO full.

ADuC7121

I²C Master Receive Registers

This 8-bit MMR is the I²C master receive register.

Name: I2C0MRX, I2C1MRX
Address: 0xFFFF0888, 0xFFFF0908
Default value: 0x00
Access: Read only

I²C Master Transmit Registers

This 8-bit MMR is the I²C master transmit register.

Name: I2C0MTX, I2C1MTX
Address: 0xFFFF088C, 0xFFFF090C
Default value: 0x00
Access: Write only

I²C Master Read Count Registers

This 16-bit MMR holds the required number of bytes when the master begins a read sequence from a slave device.

Name: I2C0MCNT0, I2C1MCNT0
Address: 0xFFFF0890, 0xFFFF0910
Default value: 0x0000
Access: Read and write

Table 89. I2CxMCNT0 MMR Bit Descriptions

Bit	Name	Description
15:9		Reserved.
8	I2CRECNT	Set this bit if greater than 256 bytes are required from the slave. Clear this bit when reading 256 bytes or less.
7:0	I2CRCNT	These 8 bits hold the number of bytes required during a slave read sequence, minus 1. If only a single byte is required, set these bits to 0.

I²C Master Current Read Count Registers

This 8-bit MMR holds the number of bytes received so far during a read sequence with a slave device.

Name: I2C0MCNT1, I2C1MCNT1
Address: 0xFFFF0894, 0xFFFF0914
Default value: 0x00
Access: Read only

I²C Address 0 Registers

This 8-bit MMR holds the 7-bit slave address + the read/write bit when the master begins communicating with a slave.

Name: I2C0ADR0, I2C1ADR0
Address: 0xFFFF0898, 0xFFFF0918
Default value: 0x00
Access: Read and write

Table 90. I2CxADR0 MMR in 7-Bit Address Mode

Bit	Name	Description
7:1	I2CADR	These bits contain the 7-bit address of the required slave device.
0	R/W	Bit 0 is the read/write bit. When this bit = 1, a read sequence is requested. When this bit = 0, a write sequence is requested.

Table 91. I2CxADR0 MMR in 10-Bit Address Mode

Bit	Name	Description
7:3		These bits must be set to [11110b] in 10-bit addressing mode.
2:1	I2CMADR	These bits contain ADDR[9:8] in 10-bit addressing mode.
0	R/W	Read/write bit. When this bit = 1, a read sequence is requested. When this bit = 0, a write sequence is requested.

I²C Address 1 Register

This 8-bit MMR is used in 10-bit addressing mode only. This register contains the least significant byte of the address.

Name: I2C0ADR1, I2C1ADR1
Address: 0xFFFF089C, 0xFFFF091C
Default value: 0x00
Access: Read and write

Table 92. I2CxADR1 MMR in 10-Bit Address Mode

Bit	Name	Description
7:0	I2CLADR	These bits contain ADDR[7:0] in 10-bit addressing mode.

I²C Master Clock Control Register

This MMR controls the frequency of the I²C clock generated by the master on to the SCL pin.

Name: I2C0DIV, I2C1DIV

Address: 0xFFFF08A4, 0xFFFF0924

Default value: 0x1F1F

Access: Read and write

I²C Slave Registers**I²C Slave Control Register**

This 16-bit MMR configures the I²C peripheral in slave mode.

Name: I2C0SCTL, I2C1SCTL

Address: 0xFFFF08A8, 0xFFFF0928

Default value: 0x0000

Access: Read and write

Table 93. I2CxDIV MMR

Bit	Name	Description
15:8	DIVH	These bits control the duration of the high period of SCL.
7:0	DIVL	These bits control the duration of the low period of SCL.

Table 94. I2CxSCTL MMR Bit Designations

Bit	Name	Description
15:11		Reserved bits.
10	I2CSTXENI	Slave transmit interrupt enable bit. Set this bit to enable an interrupt after a slave transmits a byte. Clear this interrupt source.
9	I2CSRXENI	Slave receive interrupt enable bit. Set this bit to enable an interrupt after the slave receives data. Clear this interrupt source.
8	I2CSSENI	I ² C stop condition detected interrupt enable bit. Set this bit to enable an interrupt on detecting a stop condition on the I ² C bus. Clear this interrupt source.
7	I2CNACKEN	I ² C no acknowledge enable bit. Set this bit to no acknowledge the next byte in the transmission sequence. Clear this bit to let the hardware control the acknowledge/no acknowledge sequence.
6	I2CSSEN	I ² C slave SCL stretch enable bit. Set this bit to 1 to enable clock stretching. When SCL is low, setting this bit forces the device to hold SCL low until I2CSSEN is cleared. If SCL is high, setting this bit forces the device to hold SCL low after the next falling edge. Clear this bit to disable clock stretching.
5	I2CSETEN	I ² C early transmit interrupt enable bit. Setting this bit enables a transmit request interrupt just after the positive edge of SCL during the read bit transmission. Clear this bit to enable a transmit request interrupt just after the negative edge of SCL during the read bit transmission.
4	I2CGCLR	I ² C general call status and ID clear bit. Writing a 1 to this bit clears the general call status and ID bits in the I2CxSSTA register. Clear this bit at all other times.
3	I2CHGCEN	I ² C hardware general call enable. Hardware general call enable. When this bit and Bit 2 are set, and having received a general call (Address 0x00) and a data byte, the device checks the contents of the I2CALT against the receive register. If the contents match, the device has received a hardware general call. This is used if a device needs urgent attention from a master device without knowing which master it needs to turn to. This is a "to whom it may concern" call. The ADuC7121 watches for these addresses. The device that requires attention embeds its own address into the message. All masters listen, and the one that can handle the device contacts its slave and acts appropriately. The LSB of the I2CxALT register should always be written to 1, as per the I ² C January 2000 bus specification. Set this bit and I2CGCEN to enable hardware general call recognition in slave mode. Clear to disable recognition of hardware general call commands.
2	I2CGCEN	I ² C general call enable. Set this bit to enable the slave device to acknowledge an I ² C general call, Address 0x00 (write). The device then recognizes a data bit. If it receives a 0x06 (reset and write programmable part of the slave address by hardware) as the data byte, the I ² C interface resets as per the I ² C January 2000 bus specification. This command can be used to reset an entire I ² C system. If it receives a 0x04 (write programmable part of the slave address by hardware) as the data byte, the general call interrupt status bit sets on any general call. The user must take corrective action by reprogramming the device address. Set this bit to allow the slave acknowledge I ² C general call commands. Clear to disable recognition of general call commands.
1	Reserved	Always set this bit to 0.
0	I2CSEN	I ² C slave enable bit. Set by the user to enable I ² C slave mode. Clear to disable I ² C slave mode.

I²C Slave Status Registers

These 16-bit MMRs are the I²C status registers in slave mode.

Name: I2C0SSTA, I2C1SSTA

Address: 0xFFFFF08AC, 0xFFFFF092C

Default value: 0x0000, 0x0000

Access: Read and write

Table 95. I2CxSSTA MMR Bit Designations

Bit	Name	Description
15		Reserved bit.
14	I2CSTA	This bit is set to 1 if: A start condition followed by a matching address is detected. A start byte (0x01) is received. General calls are enabled and a general call code of (0x00) is received. This bit is cleared on receiving a stop condition.
13	I2CREPS	This bit is set to 1 if a repeated start condition is detected. This bit is cleared on receiving a stop condition.
12:11	I2CID[1:0]	I ² C address matching register. These bits indicate which I2CxIDx register matches the received address. [00] = Received address matches I2CxID0. [01] = Received address matches I2CxID1. [10] = Received address matches I2CxID2. [11] = Received address matches I2CxID3.
10	I2CSS	I ² C stop condition after start detected bit. This bit is set to 1 when a stop condition is detected after a previous start and matching address. When the I2CSSENI bit in I2CxSCTL is set, an interrupt is generated. This bit is cleared by reading this register.
9:8	I2CGCID[1:0]	I ² C general call ID bits. [00] = no general call received. [01] = general call reset and program address. [10] = general program address. [11] = general call matching alternative ID. Clear these bits by writing a 1 to the I2CGCCLR bit in I2CxSCTL. Note that these bits are not cleared by a general call reset command.
7	I2CGC	I ² C general call status bit. This bit is set to 1 if the slave receives a general call command of any type. If the command received was a reset command, all registers return to their default state. If the command received was a hardware general call, the Rx FIFO holds the second byte of the command and this can be compared with the I2CxALT register. Clear this bit by writing a 1 to the I2CGCCLR bit in I2CxSCTL.
6	I2CSBUSY	I ² C slave busy status bit. Set to 1 when the slave receives a start condition. Cleared by hardware under the following conditions: The received address does not match any of the I2CxIDx registers. The slave device receives a stop condition. A repeated start address does not match any of the I2CxIDx registers.
5	I2CSNA	I ² C slave no acknowledge data bit. This bit sets to 1 when the slave responds to a bus address with a no acknowledge. This bit is asserted under the following conditions: If no acknowledge was returned because there was no data in the Tx FIFO. If the I2CNACKEN bit was set in the I2CxSCTL register. This bit is cleared in all other conditions.

ADuC7121

Bit	Name	Description
4	I2CSRxFO	Slave Rx FIFO overflow. This bit is set to 1 when a byte is written to the Rx FIFO when it is already full. This bit is cleared in all other conditions.
3	I2CSRxQ	I ² C slave receive request bit. This bit is set to 1 when the Rx FIFO of the slave is not empty. This bit causes an interrupt to occur if the I2CSRxENI bit in I2CxSCTL is set. The Rx FIFO must be read or flushed to clear this bit.
2	I2CSTxQ	I ² C slave transmit request bit. This bit is set to 1 when the slave receives a matching address followed by a read. If the I2CSETEN bit in I2CxSCTL is = 0, this bit goes high just after the negative edge of SCL during the read bit transmission. If the I2CSETEN bit in I2CxSCTL is = 1, this bit goes high just after the positive edge of SCL during the read bit transmission. This bit causes an interrupt to occur if the I2CSTxENI bit in I2CxSCTL is set. This bit is cleared in all other conditions.
1	I2CSTFE	I ² C slave FIFO underflow status bit. This bit is high if the Tx FIFO is empty when a master requests data from the slave. This bit asserts at the rising edge of SCL during the read bit. This bit clears in all other conditions.
0	I2CETSTA	I ² C slave early transmit FIFO status bit. If the I2CSETEN bit in I2CxSCTL is = 0, this bit goes high if the slave Tx FIFO is empty. If the I2CSETEN bit in I2CxSCTL is = 1, this bit goes high just after the positive edge of SCL during the write bit transmission. This bit asserts once only for a transfer. This bit is cleared after being read.

I²C Slave Receive Registers

This 8-bit MMR is the I²C slave receive register.

Name: I2C0SRX, I2C1SRX
 Address: 0xFFFF08B0, 0xFFFF0930
 Default value: 0x00
 Access: Read only

I²C Slave Transmit Registers

This 8-bit MMR is the I²C slave transmit register.

Name: I2C0STX, I2C1STX
 Address: 0xFFFF08B4, 0xFFFF0934
 Default value: 0x00
 Access: Write only

I²C Hardware General Call Recognition Registers

This 8-bit MMR is used with hardware general calls when I2CxSCTL bit 3 is set to 1. This register is used in cases where a master is unable to generate an address for a slave, and instead, the slave must generate the address for the master.

Name: I2C0ALT, I2C1ALT
 Address: 0xFFFF08B8, 0xFFFF0938
 Default value: 0x00
 Access: Read and write

I²C Slave Device ID Registers**I2C0IDx Registers**

These eight I2C0IDx 8-bit MMRs are programmed with I²C bus IDs of the slave. See the section I2C Bus Addresses for further details.

Name: I2C0ID0
 Address: 0xFFFF08BC
 Default value: 0x00
 Access: Read and write

Name: I2C0ID1
 Address: 0xFFFF08C0
 Default value: 0x00
 Access: Read and write

Name: I2C0ID2
 Address: 0xFFFF08C4
 Default value: 0x00
 Access: Read and write

Name: I2C0ID3
 Address: 0xFFFF08C8
 Default value: 0x00
 Access: Read and write

Name: I2C1ID0
 Address: 0xFFFF093C
 Default value: 0x00
 Access: Read and write

Name: I2C1ID1
 Address: 0xFFFF0940
 Default value: 0x00
 Access: Read and write

Name: I2C1ID2
 Address: 0xFFFF0944
 Default value: 0x00
 Access: Read and write

Name: I2C1ID3
 Address: 0xFFFF0948
 Default value: 0x00
 Access: Read and write

I²C COMMON REGISTERS

I²C FIFO Status Registers

These 16-bit MMRs contain the status of the Rx/Tx FIFOs in both master and slave modes.

Name: I2C0FSTA
 Address: 0xFFFF08CC
 Default value: 0x0000
 Access: Read and write

Name: I2C1FSTA
 Address: 0xFFFF094C
 Default value: 0x0000
 Access: Read and write

Table 96. I2CxFSTA MMR Bit Designations

Bit	Name	Description
15:10		Reserved bits.
9	I2CFMTX	Set this bit to 1 to flush the master Tx FIFO.
8	I2CFSTX	Set this bit to 1 to flush the slave Tx FIFO.
7:6	I2CMRXSTA	I ² C master receive FIFO status bits. [00] = FIFO empty. [01] = byte written to FIFO. [10] = one byte in FIFO. [11] = FIFO full.
5:4	I2CMTXSTA	I ² C master transmit FIFO status bits. [00] = FIFO empty. [01] = byte written to FIFO. [10] = one byte in FIFO. [11] = FIFO full.
3:2	I2CSRXSTA	I ² C slave receive FIFO status bits. [00] = FIFO empty. [01] = byte written to FIFO. [10] = one byte in FIFO. [11] = FIFO full.
1:0	I2CSTXSTA	I ² C slave transmit FIFO status bits. [00] = FIFO empty. [01] = byte written to FIFO. [10] = one byte in FIFO. [11] = FIFO full.

SERIAL PERIPHERAL INTERFACE

The ADuC7121 integrates a complete hardware serial peripheral interface (SPI) on-chip. SPI is an industry standard, synchronous serial interface that allows eight bits of data to be synchronously transmitted and simultaneously received, that is, full duplex up to a maximum bit rate of 20 Mbps.

The SPI port can be configured for master or slave operation and typically consists of four pins: P0.3/MISO/PLAO[12]/SYNC, P0.4/MOSI/PLAI[11]/TRIP, P0.2/SPICLK/ADC_{BUSY}/PLAO[13], and P0.5/ $\overline{\text{CS}}$ /PLAI[10]/ADC_{CONVST}.

SPI MISO (MASTER IN, SLAVE OUT) PIN

MISO on the P0.3/MISO/PLAO[12]/SYNC pin is configured as an input line in master mode and an output line in slave mode. Connect the MISO line on the master (data in) to the MISO line in the slave device (data out). The data is transferred as byte wide (8-bit) serial data, MSB first.

SPI MOSI (MASTER OUT, SLAVE IN) PIN

MOSI on the P0.4/MOSI/PLAI[11]/TRIP pin is configured as an output line in master mode and an input line in slave mode. The MOSI line on the master (data out) should be connected to the MOSI line in the slave device (data in). The data is transferred as byte wide (8-bit) serial data, MSB first.

SPICLK (SERIAL CLOCK I/O) PIN

The master serial clock (SPICLK) synchronizes the data being transmitted and received through the MOSI SPICLK period. Therefore, a byte is transmitted/received after eight SPICLK periods. The P0.2/SPICLK/ADC_{BUSY}/PLAO[13] pin is configured as an output in master mode and as an input in slave mode.

In master mode, the polarity and phase of the clock are controlled by the SPICON register, and the bit rate is defined in the SPIDIV register as follows:

$$f_{\text{SERIAL CLOCK}} = \frac{f_{\text{UCLK}}}{2 \times (1 + \text{SPIDIV})}$$

The maximum speed of the SPI clock is independent on the clock divider bits.

In slave mode, the SPICON register must be configured with the phase and polarity of the expected input clock. The slave accepts data from an external master up to 10 Mbps.

In both master and slave modes, data is transmitted on one edge of the SPICLK signal and sampled on the other. Therefore, it is

important that the polarity and phase are configured the same for the master and slave devices.

SPI CHIP SELECT INPUT PIN

In SPI slave mode, a transfer is initiated by the assertion of $\overline{\text{CS}}$ on the P0.5/ $\overline{\text{CS}}$ /PLAI[10]/ADC_{CONVST} pin. $\overline{\text{CS}}$ is an active low input signal. The SPI port then transmits and receives 8-bit data until the transfer is concluded by deassertion of $\overline{\text{CS}}$. In slave mode, $\overline{\text{CS}}$ is always an input.

In SPI master mode, $\overline{\text{CS}}$ is an active low output signal. It asserts itself automatically at the beginning of a transfer and deasserts itself upon completion.

CONFIGURING EXTERNAL PINS FOR SPI FUNCTIONALITY

The SPI pins of the ADuC7121 device are P0.2 to P0.5.

- P0.5/ $\overline{\text{CS}}$ /PLAI[10]/ADC_{CONVST} is the slave chip select pin. In slave mode, this pin is an input and must be driven low by the master. In master mode, this pin is an output and goes low at the beginning of a transfer and high at the end of a transfer.
- P0.2/SPICLK/ADC_{BUSY}/PLAO[13] is the SPICLK pin.
- P0.3/MISO/PLAO[12]/SYNC is the master in, slave out pin.
- P0.4/MOSI/PLAI[11]/TRIP is the master out, slave in pin.

To configure P0.2 to P0.5 for SPI mode, see the General-Purpose Input/Output section.

SPI REGISTERS

The following MMR registers control the SPI interface: SPISTA, SPIRX, SPITX, SPIDIV, and SPICON.

SPI Status Register

This 32-bit MMR contains the status of the SPI interface in both master and slave modes.

Name:	SPISTA
Address:	0xFFFF0A00
Default value:	0x0000
Access:	Read only

Table 97. SPISTA MMR Bit Designations

Bit	Name	Description
15:12		Reserved bits.
11	SPIREX	SPI Rx FIFO excess bytes present. This bit is set when there are more bytes in the Rx FIFO than indicated in the SPIMDE bits in SPICON. This bit is cleared when the number of bytes in the FIFO is equal or less than the number in SPIMDE.
10:8	SPIRXFSTA[2:0]	SPI Rx FIFO status bits. [000] = Rx FIFO is empty. [001] = one valid byte in the FIFO. [010] = two valid bytes in the FIFO. [011] = three valid bytes in the FIFO. [100] = four valid bytes in the FIFO.
7	SPIFOF	SPI Rx FIFO overflow status bit. Set when the Rx FIFO was already full when new data was loaded to the FIFO. This bit generates an interrupt except when SPIRFLH is set in SPICON. Cleared when the SPISTA register is read.
6	SPIRXIRQ	SPI Rx IRQ status bit. Set when a receive interrupt occurs. This bit is set when SPITMDE in SPICON is cleared and the required number of bytes have been received. Cleared when the SPISTA register is read.
5	SPITXIRQ	SPI Tx IRQ status bit. Set when a transmit interrupt occurs. This bit is set when SPITMDE in SPICON is set and the required number of bytes have been transmitted. Cleared when the SPISTA register is read.
4	SPITXUF	SPI Tx FIFO underflow. This bit is set when a transmit is initiated without any valid data in the Tx FIFO. This bit generates an interrupt except when SPITFLH is set in SPICON. Cleared when the SPISTA register is read.
3:1	SPITXFSTA[2:0]	SPI Tx FIFO status bits. [000] = Tx FIFO is empty. [001] = one valid byte in the FIFO. [010] = two valid bytes in the FIFO. [011] = three valid bytes in the FIFO. [100] = four valid bytes in the FIFO.
0	SPIISTA	SPI interrupt status bit. Set to 1 when an SPI based interrupt occurs. Cleared after reading SPISTA.

SPIRX Register

This 8-bit MMR is the SPI receive register.

Name: SPIRX
Address: 0xFFFF0A04
Default value: 0x00
Access: Read only

SPITX Register

This 8-bit MMR is the SPI transmit register.

Name: SPITX
Address: 0xFFFF0A08
Default value: 0x00
Access: Write only

SPIDIV Register

This 8-bit MMR is the SPI baud rate selection register.

Name: SPIDIV
Address: 0xFFFF0A0C
Default value: 0x00
Access: Read and write

SPI Control Register

This 16-bit MMR configures the SPI peripheral in both master and slave modes.

Name: SPICON
Address: 0xFFFF0A10
Default value: 0x0000
Access: Read and write

Table 98. SPICON MMR Bit Designations

Bit	Name	Description
15:14	SPIIMDE	SPI IRQ mode bits. These bits configure when the Tx/Rx interrupts occur in a transfer. [00] = Tx interrupt occurs when one byte has been transferred. Rx interrupt occurs when one or more bytes have been received into the FIFO. [01] = Tx interrupt occurs when two bytes has been transferred. Rx interrupt occurs when two or more bytes have been received into the FIFO. [10] = Tx interrupt occurs when three bytes has been transferred. Rx interrupt occurs when three or more bytes have been received into the FIFO. [11] = Tx interrupt occurs when four bytes has been transferred. Rx interrupt occurs when the Rx FIFO is full, or four bytes present.
13	SPITFLH	SPI Tx FIFO flush enable bit. Set this bit to flush the Tx FIFO. This bit does not clear itself and should be toggled if a single flush is required. If this bit is left high, then either the last transmitted value or 0x00 is transmitted depending on the SPIZEN bit. Any writes to the Tx FIFO are ignored while this bit is set. Clear this bit to disable Tx FIFO flushing.
12	SPIRFLH	SPI Rx FIFO flush enable bit. Set this bit to flush the Rx FIFO. This bit does not clear itself and should be toggled if a single flush is required. If this bit is set, all incoming data is ignored and no interrupts are generated. If this bit is set and SPITMDE = 0, a read of the Rx FIFO initiates a transfer. Clear this bit to disable Rx FIFO flushing.
11	SPICONT	Continuous transfer enable. Set by the user to enable continuous transfer. In master mode, the transfer continues until no valid data is available in the Tx register. The P0.5/ \overline{CS} /PLAI[10]/ADC _{CONVST} pin is asserted and remains asserted for the duration of each 8-bit serial transfer until Tx is empty. Cleared by the user to disable continuous transfer. Each transfer consists of a single 8-bit serial transfer. If valid data exists in the SPITX register, then a new transfer is initiated after a stall period of one serial clock cycle.
10	SPILP	Loopback enable bit. Set by the user to connect MISO to MOSI and test software. Cleared by the user to be in normal mode.
9	SPIOEN	Slave MISO output enable bit. Set this bit for normal operation of MISO. Clear this bit to disable the output driver on the MISO pin. The MISO pin is open drain when this bit is clear.
8	SPIROW	SPIRX overflow overwrite enable. Set by the user, the valid data in the Rx register is overwritten by the new serial byte that is received. Cleared by the user, the new serial byte that is received is discarded.
7	SPIZEN	SPI transmits zeros when Tx FIFO is empty. Set this bit to transmit 0x00 when there is no valid data in the Tx FIFO. Clear this bit to transmit the last transmitted value when there is no valid data in the Tx FIFO.
6	SPITMDE	SPI transfer and interrupt mode. Set by the user to initiate a transfer with a write to the SPITX register. Interrupt occurs only when Tx is empty. Cleared by the user to initiate a transfer with a read of the SPIRX register. Interrupt occurs only when Rx is full.
5	SPIILF	LSB first transfer enable bit. Set by the user, the LSB is transmitted first. Cleared by the user, the MSB is transmitted first.
4	SPIWOM	SPI wired or mode enable bit. Set to 1 to enable open-drain data output enable. External pull-ups are required on data output pins. Clear for normal output levels.
3	SPICPO	Serial clock polarity mode bit. Set by the user, the serial clock idles high. Cleared by the user, the serial clock idles low.
2	SPICPH	Serial clock phase mode bit. Set by the user, the serial clock pulses at the beginning of each serial bit transfer. Cleared by the user, the serial clock pulses at the end of each serial bit transfer.
1	SPIMEN	Master mode enable bit. Set by the user to enable master mode. Cleared by the user to enable slave mode.
0	SPIEN	SPI enable bit. Set by the user to enable the SPI. Cleared by the user to disable the SPI.

PROGRAMMABLE LOGIC ARRAY (PLA)

The ADuC7121 integrates a fully programmable logic array (PLA) that consists of two independent but interconnected PLA blocks. Each block consists of eight PLA elements, giving each part a total of 16 PLA elements.

Each PLA element contains a dual input lookup table that can be configured to generate any logic output function based on two inputs and a flip-flop. This is represented in Figure 36.

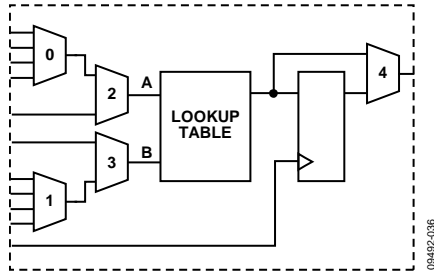

Figure 36. PLA Element

In total, 32 GPIO pins are available on each ADuC7121 for the PLA. These include 16 input pins and 16 output pins, which need

to be configured in the GPxCON register as PLA pins before using the PLA. Note that the comparator output is also included as one of the 16 input pins, and that the JTAG TDI and TDO pins are included as PLA outputs. If you want to use JTAG programming or debugging, then you cannot use the JTAG TDI and TDO pins as PLA outputs.

The PLA is configured via a set of user MMRs. The output(s) of the PLA can be routed to the internal interrupt system, to the ADC_{CONVST} signal of the ADC, to an MMR, or to any of the 16 PLA output pins.

The two blocks can be interconnected as follows:

- Output of Element 15 (Block 1) can be fed to Input 0 of Mux 0 of Element 0 (Block 0).
- Output of Element 7 (Block 0) can be fed to the Input 0 of Mux 0 of Element 8 (Block 1).

Table 99. Element Input/Output

PLA Block 0			PLA Block 1		
Element	Input	Output	Element	Input	Output
0	P2.7	P3.0	8	P1.4	P3.4
1	P2.2	P3.1	9	P1.5	P3.5
2	P0.6	P3.2	10	P0.5	P3.6
3	P0.7	P3.3	11	P0.4	P3.7
4	P0.1	P1.7	12	P2.1	P0.3
5	P0.0	P1.6	13	P2.0	P0.2
6	P1.1	P2.5	14	P2.3	P1.3
7	P1.0	P2.4	15	P2.6	P1.2

PLA MMRS INTERFACE

The PLA peripheral interface consists of the 21 MMRs described in the following sections.

PLAELMx Registers

PLAELMx are Element 0 to Element 15 control registers. They configure the input and output mux of each element, select the function in the look-up table, and bypass/use the flip-flop. See Table 101 and Table 104.

Table 100. PLAELMx MMR Addresses (Default Value = 0x0000, Access is Read/Write)

Name	Address
PLAELM0	0xFFFF0B00
PLAELM1	0xFFFF0B04
PLAELM2	0xFFFF0B08
PLAELM3	0xFFFF0B0C
PLAELM4	0xFFFF0B10
PLAELM5	0xFFFF0B14
PLAELM6	0xFFFF0B18
PLAELM7	0xFFFF0B1C
PLAELM8	0xFFFF0B20
PLAELM9	0xFFFF0B24
PLAELM10	0xFFFF0B28
PLAELM11	0xFFFF0B2C
PLAELM12	0xFFFF0B30
PLAELM13	0xFFFF0B34
PLAELM14	0xFFFF0B38
PLAELM15	0xFFFF0B3C

Table 101. PLAELMx MMR Bit Descriptions

Bit	Value	Description
31:11		Reserved.
10:9		Mux 0 control (see Table 104).
8:7		Mux 1 control (see Table 104).
6		Mux 2 control. Set by the user to select the output of Mux 0. Cleared by the user to select the bit value from PLADIN.
5		Mux 3 control. Set by the user to select the input pin of the particular element. Cleared by the user to select the output of Mux 1.
4:1	0000 0001 0010 0011 0100 0101 0110 0111 1000 1001 1010 1011 1100 1101 1110 1111	Look up table control. 0. NOR. B AND NOT A. NOT A. A AND NOT B. NOT B. EXOR. NAND. AND. EXNOR. B. NOT A OR B. A. A OR NOT B. OR. 1.
0		Mux 4 control. Set by the user to bypass the flip-flop. Cleared by the user to select the flip-flop (cleared by default).

Table 102. Feedback Configuration

Bit	Value	PLAELM0	PLAELM1 to PLAELM7	PLAELM8	PLAELM9 to PLAELM15
10:9	00	Element 15	Element 0	Element 7	Element 8
	01	Element 2	Element 2	Element 10	Element 10
	10	Element 4	Element 4	Element 12	Element 12
	11	Element 6	Element 6	Element 14	Element 14
8:7	00	Element 1	Element 1	Element 9	Element 9
	01	Element 3	Element 3	Element 11	Element 11
	10	Element 5	Element 5	Element 13	Element 13
	11	Element 7	Element 7	Element 15	Element 15

ADuC7121

PLACK Register

PLACK is the clock selection for the flip-flops of Block 0 and Block 1. The maximum frequency when using the GPIO pins as the clock input for the PLA blocks is 41.78 MHz.

Name: PLACK
 Address: 0xFFFF0B40
 Default value: 0x00
 Access: Read and write

Table 103. PLACK MMR Bit Descriptions

Bit	Value	Description
7		Reserved.
6:4		Block 1 clock source selection.
	000	GPIO clock on P0.5 of the P0.5/ \overline{CS} /PLAI[10]/ADC _{CONVST} pin.
	001	GPIO clock on P0.0 of the P0.0/SCL0/PLAI[5] pin.
	010	GPIO clock on the P0.7 of the P0.7/ \overline{TRST} /PLAI[3] pin.
	011	HCLK (core clock).
	100	OCLK (32.768 kHz external crystal).
	101	Timer1 overflow.
	Other	Reserved.
3		Reserved.
2:0		Block 0 clock source selection.
	000	GPIO clock on P0.5, on P0.5 of the P0.5/ \overline{CS} /PLAI[10]/ADC _{CONVST} pin.
	001	GPIO clock on P0.0 of the P0.0/SCL0/PLAI[5] pin.
	010	GPIO clock on P0.7 of the P0.7/ \overline{TRST} /PLAI[3] pin.
	011	HCLK (core clock).
	100	OCLK (32.768 kHz external crystal).
	101	Timer1 overflow.
	Other	Reserved.

PLAIRQ Register

PLAIRQ enables IRQ0 and/or IRQ1 and selects the source of the normal interrupt request IRQ (IRQ).

Name: PLAIRQ
 Address: 0xFFFF0B44
 Default value: 0x0000
 Access: Read and write

Table 104. PLAIRQ MMR Bit Descriptions

Bit	Value	Description
15:13		Reserved.
12		PLA IRQ1 enable bit. Set by the user to enable IRQ1 output from the PLA. Cleared by the user to disable IRQ1 output from the PLA.

Bit	Value	Description
11:8	0000 0001 1111	PLA IRQ1 source. PLA Element 0. PLA Element 1. PLA Element 15.
7:5		Reserved.
4		PLA IRQ0 enable bit. Set by the user to enable IRQ0 output from the PLA. Cleared by the user to disable IRQ0 output from the PLA.
3:0	0000 0001 1111	PLA IRQ0 source. PLA Element 0. PLA Element 1. PLA Element 15.

PLAAD Register

PLAAD is the PLA source for the ADC start conversion signal.

Name: PLAAD
 Address: 0xFFFF0B48
 Default value: 0x00000000
 Access: Read and write

Table 105. PLAAD MMR Bit Descriptions

Bit	Value	Description
31:5		Reserved.
4		ADC start conversion enable bit. Set by the user to enable an ADC start conversion from the PLA. Cleared by the user to disable an ADC start conversion from the PLA.
3:0	0000 0001 1111	ADC start conversion source. PLA Element 0. PLA Element 1. PLA Element 15.

PLADIN Register

PLADIN is a data input MMR for PLA.

Name: PLADIN
 Address: 0xFFFF0B4C
 Default value: 0x00000000
 Access: Read and write

Table 106. PLADIN MMR Bit Descriptions

Bit	Description
31:16	Reserved.
15:0	Input bit from Element 15 to Element 0.

PLADOUT Register

PLADOUT is a data output MMR for PLA. This register is always updated.

Name: PLADOUT
 Address: 0xFFFF0B50
 Default value: 0x00000000
 Access: Read only

Table 107. PLADOUT MMR Bit Descriptions

Bit	Description
31:16	Reserved.
15:0	Output bit from Element 15 to Element 0.

PLALCK Register

PLALCK is a PLA lock option. Bit 0 is written only once. When set, it does not allow modifying any of the PLA MMRs, except PLADIN. A PLA tool is provided in the development system to easily configure the PLA.

Name: PLALCK
 Address: 0xFFFF0B54
 Default value: 0x00
 Access: Write only

INTERRUPT SYSTEM

Table 108. IRQ/FIQ MMRs Bit Designations

Bit	Description	Comments
0	All interrupts OR'ed (FIQ only)	This bit is set if any FIQ is active
1	Software interrupt	User programmable interrupt source
2	Timer0	General-Purpose Timer0
3	Timer1	General-Purpose Timer1
4	Timer2 or wake-up timer	General-Purpose Timer2 or wake-up timer
5	Timer3 or watchdog timer	General-Purpose Timer3 or watchdog timer
6	Timer4	General-Purpose Timer4
7	IDAC fault	IDAC fault IRQ
8	PSM	Power supply monitor
9	Undefined	This bit is not used
10	Flash Control 0	Flash controller for Block 0 interrupt
11	Flash Control 1	Flash controller for Block 1 interrupt
12	ADC	ADC interrupt source bit
13	UART	UART interrupt source bit
14	SPI	SPI interrupt source bit
15	I ² C0 Master IRQ	I ² C master interrupt source bit
16	I ² C0 Slave IRQ	I ² C slave interrupt source bit
17	I ² C1 Master IRQ	I ² C master interrupt source bit
18	I ² C1 Slave IRQ	I ² C slave interrupt source bit
19	XIRQ0 (GPIO IRQ0)	External Interrupt 0
20	XIRQ1 (GPIO IRQ1)	External Interrupt 1
21	XIRQ2 (GPIO IRQ2)	External Interrupt 2
22	XIRQ3 (GPIO IRQ3)	External Interrupt 3
23	PWM	PWM trip interrupt source bit
24	XIRQ4 (GPIO IRQ4)	External Interrupt 4
25	XIRQ5 (GPIO IRQ5)	External Interrupt 5
26	PLA IRQ0	PLA Block 0 IRQ bit
27	PLA IRQ1	PLA Block 1 IRQ bit

There are 27 interrupt sources on the ADuC7121 that are controlled by the interrupt controller. All interrupts are generated from the on-chip peripherals, except for the software interrupt (SWI), which is programmable by the user. The ARM7TDMI CPU core recognizes interrupts as one of two types only: a normal interrupt request (IRQ) and a fast interrupt request (FIQ). All the interrupts can be masked separately.

The control and configuration of the interrupt system is managed through a number of interrupt related registers. The bits in each IRQ and FIQ register represent the same interrupt source as described in Table 108.

The ADuC7121 contains a vectored interrupt controller (VIC) that supports nested interrupts up to eight levels. The VIC also allows the programmer to assign priority levels to all interrupt sources. Interrupt nesting needs to be enabled by setting the ENIRQN bit in the IRQCONN register. A number of extra MMRs are used when the full-vectored interrupt controller is enabled.

Upon entering the interrupt service routine (ISR), immediately save IRQSTA/FIQSTA to ensure that all valid interrupt sources are serviced.

NORMAL INTERRUPT REQUEST (IRQ)

The normal interrupt request (IRQ) is the exception signal to enter the IRQ mode of the processor. It services general-purpose interrupt handling of internal and external events.

All 32 bits are logically OR'ed to create a single IRQ signal to the ARM7TDMI core. The four 32-bit registers dedicated to IRQ follow.

IRQSIG Register

IRQSIG reflects the status of the different IRQ sources. If a peripheral generates an IRQ signal, the corresponding bit in the IRQSIG is set; otherwise, it is cleared. The IRQSIG bits clear when the interrupt in the particular peripheral is cleared. All IRQ sources can be masked in the IRQEN MMR. IRQSIG is a read-only register. Do not use this register in an interrupt service routine for determining the source of an IRQ exception; use only IRQSTA for this purpose.

Name: IRQSIG
 Address: 0xFFFF0004
 Default value: 0x00000000
 Access: Read only

IRQEN Register

IRQEN provides the value of the current enable mask. When a bit is set to 1, the corresponding source request is enabled to create an IRQ exception. When a bit is set to 0, the corresponding source request is disabled or masked, which does not create an IRQ exception. The IRQEN register cannot be used to disable an interrupt.

Name: IRQEN
 Address: 0xFFFF0008
 Default value: 0x00000000
 Access: Read and write

IRQCLR Register

IRQCLR is a write-only register that allows the IRQEN register to clear to mask an interrupt source. Each bit that is set to 1 clears the corresponding bit in the IRQEN register without affecting the remaining bits. The pair of registers, IRQEN and IRQCLR, allows independent manipulation of the enable mask without requiring an atomic read-modify-write.

Use this register to disable an interrupt source only when:

- The device is in the interrupt sources interrupt service routine.
- The peripheral is temporarily disabled by its own control register.

Do not use the IRQCLR to disable an IRQ source if that IRQ source has an interrupt pending or could have an interrupt pending.

Name: IRQCLR
 Address: 0xFFFF000C
 Default value: 0x00000000
 Access: Write only

IRQSTA Register

IRQSTA is a read-only register that provides the current enabled IRQ source status (effectively a logic AND of the IRQSIG and IRQEN bits). When set to 1, that source generates an active IRQ request to the ARM7TDMI core. There is no priority encoder or interrupt vector generation. This function is implemented in software in a common interrupt handler routine.

Name: IRQSTA
 Address: 0xFFFF0000
 Default value: 0x00000000
 Access: Read only

FAST INTERRUPT REQUEST (FIQ)

The fast interrupt request (FIQ) is the exception signal to enter the FIQ mode of the processor. It is provided to service data transfer or communication channel tasks with low latency. The FIQ interface is identical to the IRQ interface and provides the second level interrupt (highest priority). Four 32-bit registers are dedicated to FIQ: FIQSIG, FIQEN, FIQCLR, and FIQSTA.

Bit 31 to Bit 1 of FIQSTA are logically OR'ed to create the FIQ signal to the core and to Bit 0 of both the FIQ and IRQ registers (FIQ source).

The logic for FIQEN and FIQCLR does not allow an interrupt source to be enabled in both IRQ and FIQ masks. A bit set to 1 in FIQEN clears, as a side effect, the same bit in IRQEN. Likewise, a bit set to 1 in IRQEN clears, as a side effect, the same bit in FIQEN. An interrupt source can be disabled in both IRQEN and FIQEN masks.

FIQSIG Register

FIQSIG reflects the status of the different FIQ sources. If a peripheral generates an FIQ signal the corresponding bit in the FIQSIG is set, otherwise it is cleared. The FIQSIG bits are cleared when the interrupt in the particular peripheral is cleared. All FIQ sources can be masked in the FIQEN MMR. FIQSIG is read only.

Name: FIQSIG
 Address: 0xFFFF0104
 Default value: 0x00000000
 Access: Read only

FIQEN Register

FIQEN provides the value of the current enable mask. When a bit is set to 1, the corresponding source request is enabled to create an FIQ exception. When a bit is set to 0, the corresponding source request is disabled or masked, which does not create an FIQ exception. The FIQEN register cannot be used to disable an interrupt.

FIQEN Register

Name: FIQEN
 Address: 0xFFFF0108
 Default value: 0x00000000
 Access: Read and write

FIQCLR

FIQCLR is a write-only register that allows the FIQEN register to clear to mask an interrupt source. Each bit that is set to 1 clears the corresponding bit in the FIQEN register without affecting the remaining bits. The pair of registers, FIQEN and FIQCLR, allows independent manipulation of the enable mask without requiring an atomic read-modify-write.

Use this register to disable an interrupt source only when:

- The device is in the interrupt sources interrupt service routine.
- The peripheral is temporarily disabled by its own control register.

Do not use this register to disable an FIQ source if that FIQ source has an interrupt pending or could have an interrupt pending.

FIQCLR Register

Name: FIQCLR
 Address: 0xFFFFF010C
 Default value: 0x00000000
 Access: Write only

FIQSTA

FIQSTA is a read-only register that provides the current enabled FIQ source status (effectively a logic AND of the FIQSIG and FIQEN bits). When set to 1, that source generates an active FIQ request to the ARM7TDMI core. There is no priority encoder or interrupt vector generation. This function is implemented in software in a common interrupt handler routine.

FIQSTA Register

Name: FIQSTA
 Address: 0xFFFFF0100
 Default value: 0x00000000
 Access: Read only

Programmed Interrupts

Because the programmed interrupts are not maskable, they are controlled by another register (SWICFG) that writes into both IRQSTA and IRQSIG registers and/or the FIQSTA and FIQSIG registers at the same time.

The 32-bit register dedicated to software interrupt is SWICFG described in Table 109. This MMR allows the control of a programmed source interrupt.

Table 109. SWICFG MMR Bit Designations

Bit	Description
31:3	Reserved.
2	Programmed Interrupt FIQ. Setting/clearing this bit corresponds to setting/clearing Bit 1 of FIQSTA and FIQSIG.
1	Programmed Interrupt IRQ1. Setting or clearing this bit corresponds to setting or clearing Bit 1 of IRQSTA and IRQSIG.
0	Reserved.

Any interrupt signal must be active for at least the minimum interrupt latency time, to be detected by the interrupt controller and to be detected by the user in the IRQSTA/FIQSTA register.

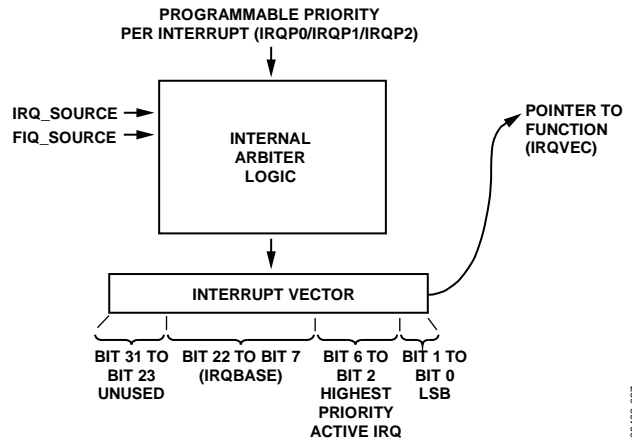

Figure 37. Interrupt Structure

Vectored Interrupt Controller (VIC)

The ADuC7121 incorporates an enhanced interrupt control system or vectored interrupt controller. The vectored interrupt controller for IRQ interrupt sources is enabled by setting Bit 0 of the IRQCONN register. Similarly, Bit 1 of IRQCONN enables the vectored interrupt controller for the FIQ interrupt sources. The vectored interrupt controller provides the following enhancements to the standard IRQ/FIQ interrupts:

- Vectored interrupts—allows a user to define separate interrupt service routine addresses for every interrupt source. This is achieved by using the IRQBASE and IRQVEC registers.
- IRQ/FIQ interrupts—can be nested up to eight levels depending on the priority settings. An FIQ still has a higher priority than an IRQ. Therefore, if the VIC is enabled for both the FIQ and IRQ and prioritization is maximized, it is possible to have 16 separate interrupt levels.
- Programmable interrupt priorities—using the IRQP0 to IRQP3 registers, an interrupt source can be assigned an interrupt priority level value between 0 and 7.

VIC MMRs**IRQBASE Register**

The vector base register, IRQBASE, is used to point to the start address of memory used to store 32 pointer addresses. These pointer addresses are the addresses of the individual interrupt service routines.

Name: IRQBASE
 Address: 0xFFFF0014
 Default value: 0x00000000
 Access: Read and write

Table 110. IRQBASE MMR Bit Designations

Bit	Type	Initial Value	Description
31:16	Read only	Reserved	Always read as 0
15:0	Read and write	0	Vector base address

IRQVEC Register

The IRQ interrupt vector register, IRQVEC points to a memory address containing a pointer to the interrupt service routine of the currently active IRQ. Read this register only when an IRQ occurs and IRQ interrupt nesting has been enabled by setting Bit 0 of the IRQCONN register.

Name: IRQVEC
 Address: 0xFFFF001C
 Default value: 0x00000000
 Access: Read and write

Table 111. IRQVEC MMR Bit Designations

Bit	Type	Initial Value	Description
31:23	Read only	0	Always read as 0.
22:7	Read and write	0	IRQBASE register value.
6:2	Read only	0	Highest priority source. This is a value between 0 and 27 representing the possible interrupt sources. For example, if the highest currently active IRQ is Timer2, these bits are [00100].
1:0	Reserved	0	Reserved bits.

Priority Registers**IRQP0 Register**

Name: IRQP0
 Address: 0xFFFF0020
 Default value: 0x00000000
 Access: Read and write

Table 112. IRQP0 MMR Bit Designations

Bit	Name	Description
31	Reserved	Reserved bit.
30:28	IDAC_Fault	A priority level of 0 to 7 can be set for an IDAC fault interrupt.
27	Reserved	Reserved bit.
26:24	T4PI	A priority level of 0 to 7 can be set for Timer4.
23	Reserved	Reserved bit.
22:20	T3PI	A priority level of 0 to 7 can be set for Timer3.
19	Reserved	Reserved bit.
18:16	T2PI	A priority level of 0 to 7 can be set for Timer2.
15	Reserved	Reserved bit.
14:12	T1PI	A priority level of 0 to 7 can be set for Timer1.
11	Reserved	Reserved bit.
10:8	T0PI	A priority level of 0 to 7 can be set for Timer0.
7	Reserved	Reserved bit.
6:4	SWINTP	A priority level of 0 to 7 can be set for the software interrupt source.
3:0	Reserved	Reserved bit.

IRQP1 Register

Name: IRQP1
 Address: 0xFFFF0024
 Default value: 0x00000000
 Access: Read and write

Table 113. IRQP1 MMR Bit Designations

Bit	Name	Description
31	Reserved	Reserved bit.
30:28	I2COMPI	A priority level of 0 to 7 can be set for I ² C 0 master.
27	Reserved	Reserved bit.
26:24	SPIPI	A priority level of 0 to 7 can be set for SPI.
23	Reserved	Reserved bit.
22:20	UARTPI	A priority level of 0 to 7 can be set for UART.
19	Reserved	Reserved bit.
18:16	ADCPI	A priority level of 0 to 7 can be set for the ADC interrupt source.
15	Reserved	Reserved bit.
14:12	Flash1PI	A priority level of 0 to 7 can be set for the Flash block 1 controller interrupt source.
11	Reserved	Reserved bit.
10:8	Flash0PI	A priority level of 0 to 7 can be set for the Flash Block 0 controller interrupt source.
7:3	Reserved	Reserved bits.
2:0	PSMPI	A priority level of 0 to 7 can be set for the power supply monitor interrupt source.

ADuC7121

IRQP2 Register

Name: IRQP2
Address: 0xFFFF0028
Default value: 0x00000000
Access: Read and write

Table 114. IRQP2 MMR Bit Designations

Bit	Name	Description
31	Reserved	Reserved bit.
30:28	PWMPPI	A priority level of 0 to 7 can be set for PWM.
27	Reserved	Reserved bit.
26:24	IRQ3PI	A priority level of 0 to 7 can be set for IRQ3.
23	Reserved	Reserved bit.
22:20	IRQ2PI	A priority level of 0 to 7 can be set for IRQ2.
19	Reserved	Reserved bit.
18:16	IRQ1PI	A priority level of 0 to 7 can be set for IRQ1.
15	Reserved	Reserved bit.
14:12	IRQ0PI	A priority level of 0 to 7 can be set for IRQ0.
11	Reserved	Reserved bit.
10:8	I2C1SPI	A priority level of 0 to 7 can be set for I ² C1 slave.
7	Reserved	Reserved bit.
6:4	I2C1MPI	A priority level of 0 to 7 can be set for I ² C1 master.
3	Reserved	Reserved bit.
2:0	I2C0SPI	A priority level of 0 to 7 can be set for I ² C0 slave.

IRQP3 Register

Name: IRQP3
Address: 0xFFFF002C
Default value: 0x00000000
Access: Read and write

IRQP3 MMR Bit Designations

Bit	Name	Description
31:15	Reserved	Reserved bit.
14:12	PLA1PI	A priority level of 0 to 7 can be set for PLA0.
11	Reserved	Reserved bit.
10:8	PLA0PI	A priority level of 0 to 7 can be set for PLA0.
7	Reserved	Reserved bit.
6:4	IRQ5PI	A priority level of 0 to 7 can be set for IRQ5.
3	Reserved	Reserved bit.
2:0	IRQ4PI	A priority level of 0 to 7 can be set for IRQ4.

IRQCONN Register

The IRQCONN register is the IRQ and FIQ control register. It contains two active bits. The first to enable nesting and prioritization of IRQ interrupts the other to enable nesting and prioritization of FIQ interrupts.

If these bits are cleared, then FIQs and IRQs can still be used, but it is not possible to nest IRQs or FIQs, nor is it possible to set an interrupt source priority level. In this default state, an FIQ does have a higher priority than an IRQ.

Name: IRQCONN
Address: 0xFFFF0030
Default value: 0x00000000
Access: Read and write

Table 115. IRQCONN MMR Bit Designations

Bit	Name	Description
31:2	Reserved	These bits are reserved and should not be written to.
1	ENFIQN	Setting this bit to 1 enables nesting of FIQ interrupts. Clearing this bit means no nesting or prioritization of FIQs is allowed.
0	ENIRQN	Setting this bit to 1 enables nesting of IRQ interrupts. Clearing this bit means no nesting or prioritization of IRQs is allowed.

IRQSTAN Register

If IRQCONN.0 is asserted and IRQVEC is read then one of these bits is asserted. The bit that asserts depends on the priority of the IRQ. If the IRQ is of Priority 0 then Bit 0 asserts, Priority 1 then Bit 1 asserts, and so forth. When a bit is set in this register, all interrupts of that priority and lower are blocked. To clear a bit in this register, all bits of a higher priority must be cleared first. It is only possible to clear one bit at a time. For example, if this register is set to 0x09 then writing 0xFF changes the register to 0x08, and writing 0xFF a second time changes the register to 0x00.

Name: IRQSTAN
Address: 0xFFFF003C
Default value: 0x00000000
Access: Read and write

Table 116. IRQSTAN MMR Bit Designations

Bit	Name	Description
31:8	Reserved	These bits are reserved and should not be written to.
7:0		Setting this bit to 1 enables nesting of FIQ interrupts. Clearing this bit means no nesting or prioritization of FIQs is allowed.

FIQVEC Register

The FIQ interrupt vector register, FIQVEC points to a memory address containing a pointer to the interrupt service routine of the currently active FIQ. Read this register only when an FIQ occurs and FIQ interrupt nesting has been enabled by setting Bit 1 of the IRQCONN register.

Name: FIQVEC
 Address: 0xFFFF011C
 Default value: 0x00000000
 Access: Read only

Table 117. FIQVEC MMR Bit Designations

Bit	Type	Initial Value	Description
31:23	Read only	0	Always read as 0.
22:7	Read and write	0	IRQBASE register value.
6:2		0	Highest priority source. This is a value between 0 and 27 representing the possible interrupt sources. For example, if the highest currently active FIQ is Timer2, then these bits are [00100].
1:0	Reserved	0	Reserved bits.

FIQSTAN Register

If IRQCONN.1 is asserted and FIQVEC is read, then one of these bits assert. The bit that asserts depends on the priority of the FIQ. If the FIQ is of Priority 0, then Bit 0 asserts; if Priority 1, then Bit 1 asserts, and so forth.

When a bit is set in this register, all interrupts of that priority and lower are blocked.

To clear a bit in this register, all bits of a higher priority must be cleared first. It is only possible to clear one bit at a time. For

example if this register is set to 0x09 then writing 0xFF changes the register to 0x08, and writing 0xFF a second time changes the register to 0x00.

Name: FIQSTAN
 Address: 0xFFFF013C
 Default value: 0x00000000
 Access: Read and write

Table 118. FIQSTAN MMR Bit Designations

Bit	Name	Description
31:8	Reserved	These bits are reserved and should not be written to.
7:0		Setting this bit to 1 enables nesting of FIQ interrupts. Clearing this bit means no nesting or prioritization of FIQs is allowed.

EXTERNAL INTERRUPTS (IRQ0 TO IRQ3)

The ADuC7121 provides up to six external interrupt sources. These external interrupts can be individually configured as level or rising/falling edge triggered.

To enable the external interrupt source, first, the appropriate bit must be set in the FIQEN or IRQEN register. To select the required edge or level to trigger on, the IRQCONE register must be appropriately configured.

To properly clear an edge based external IRQ interrupt, set the appropriate bit in the IRQCLRE register.

IRQCONE Register

Name: IRQCONE
 Address: 0xFFFF0034
 Default value: 0x00000000
 Access: Read and write

Table 119. IRQCONEMMR Bit Designations

Bit	Value	Name	Description
31:12		Reserved	These bits are reserved and should not be written to.
11:10	11 10 01 00	IRQ5SRC[1:0]	External IRQ5 triggers on falling edge. External IRQ5 triggers on rising edge. External IRQ5 triggers on low level. External IRQ5 triggers on high level.
9:8	11 10 01 00	IRQ4SRC[1:0]	External IRQ4 triggers on falling edge. External IRQ4 triggers on rising edge. External IRQ4 triggers on low level. External IRQ4 triggers on high level.
7:6	11 10 01 00	IRQ3SRC[1:0]	External IRQ3 triggers on falling edge. External IRQ3 triggers on rising edge. External IRQ3 triggers on low level. External IRQ3 triggers on high level.

ADuC7121

Bit	Value	Name	Description
5:4	11	IRQ2SRC[1:0]	External IRQ2 triggers on falling edge.
	10		External IRQ2 triggers on rising edge.
	01		External IRQ2 triggers on low level.
	00		External IRQ2 triggers on high level.
3:2	11	IRQ1SRC[1:0]	External IRQ1 triggers on falling edge.
	10		External IRQ1 triggers on rising edge.
	01		External IRQ1 triggers on low level.
	00		External IRQ1 triggers on high level.
1:0	11	IRQ0SRC[1:0]	External IRQ0 triggers on falling edge.
	10		External IRQ0 triggers on rising edge.
	01		External IRQ0 triggers on low level.
	00		External IRQ0 triggers on high level.

IRQCLRE Register

Name: IRQCLRE
 Address: 0xFFFF0038
 Default value: 0x00000000
 Access: Read and write

Table 120. IRQCLRE MMR Bit Designations

Bit	Name	Description
31:25	Reserved	These bits are reserved and should not be written to.
24	IRQ5CLRI	A 1 must be written to this bit in the IRQ5 interrupt service routine to clear an edge triggered IRQ5 interrupt.
24	IRQ4CLRI	A 1 must be written to this bit in the IRQ4 interrupt service routine to clear an edge triggered IRQ4 interrupt.
23	Reserved	This bit is reserved.
22	IRQ3CLRI	A 1 must be written to this bit in the IRQ3 interrupt service routine to clear an edge triggered IRQ3 interrupt.
21	IRQ2CLRI	A 1 must be written to this bit in the IRQ2 interrupt service routine to clear an edge triggered IRQ2 interrupt.
20	IRQ1CLRI	A 1 must be written to this bit in the IRQ1 interrupt service routine to clear an edge triggered IRQ1 interrupt.
19	IRQ0CLRI	A 1 must be written to this bit in the IRQ0 interrupt service routine to clear an edge triggered IRQ0 interrupt.
18:0	Reserved	These bits are reserved and should not be written to.

TIMERS

The ADuC7121 has five general purpose timers/counters.

- Timer0
- Timer1
- Timer2 or wake-up timer
- Timer3 or watchdog timer
- Timer4

The five timers in their normal mode of operation can be either free-running or periodic.

In free-running mode, the counter decrements/increments from the maximum/minimum value until zero scale/full scale and starts again at the maximum/minimum value.

In periodic mode, the counter decrements/increments from the value in the load register (TxLD MMR) until zero scale/full scale and starts again at the value stored in the load register.

The value of a counter can be read at any time by accessing its value register (TxVAL). Timers are started by writing in the control register of the corresponding timer (TxCON).

In normal mode, an IRQ is generated each time the value of the counter reaches zero if counting down or full scale if counting up. An IRQ can be cleared by writing any value to the clear register of the particular timer (TxCLRI).

Table 121. Event Selection (ES) Numbers

ES	Interrupt No.	Name
00000	2	RTOS timer (Timer0)
00001	3	GP Timer0 (Timer1)
00010	4	Wake-up timer (Timer2)
00011	5	Watchdog timer (Timer3)
00100	6	GP Timer4 (Timer4)
00101	7	IDAC Fault IRQ
00110	8	Power supply monitor
00111	9	Undefined
01000	10	Flash Block 0
01001	11	Flash Block 1
01010	12	ADC
01011	13	UART
01100	14	SPI
01101	15	I ² C0 master
01110	16	I ² C0 slave
01111	17	I ² C1 master
10000	18	I ² C1 slave
10001	19	External IRQ0

TIMER0—LIFETIME TIMER

Timer0 is a general-purpose, 48-bit count up, or a 16-bit count up/down timer with a programmable prescaler. Timer0 is clocked from the core clock, with a prescaler of 1, 16, 256, or 32,768. This gives a minimum resolution of 22 ns when the core is operating at 41.78 MHz and with a prescaler of one. Timer0 can also be clocked from the undivided core clock, internal 32 kHz oscillator or external 32 kHz crystal.

In 48-bit mode, Timer0 counts up from zero. The current counter value can be read from T0VAL0 and T0VAL1.

In 16-bit mode, Timer0 can count up or count down. A 16-bit value can be written to T0LD that is loaded into the counter. The current counter value can be read from T0VAL0. Timer0 has a capture register (T0CAP) that can be triggered by a selected IRQ's source initial assertion. When triggered, the current timer value is copied to T0CAP, and the timer keeps running. This feature can be used to determine the assertion of an event with more accuracy than by servicing an interrupt alone.

Timer0 reloads the value from T0LD either when TIMER0 overflows or immediately when T0ICLR is written.

Timer0 interface consists of six MMRs as listed in Table 122.

Table 122. Timer0 Interface MMRs

Name	Description
T0LD	16-bit register that holds the 16-bit value loaded into the counter. Available only in 16-bit mode.
T0CAP	16-bit register that holds the 16-bit value captured by an enabled IRQ event. Available only in 16-bit mode.
T0VAL0/T0VAL1	T0VAL0 is a 16-bit register that holds the 16 least significant bits (LSBs). T0VAL1 is a 32-bit register that holds the 32 most significant bits (MSBs). T0VAL0 and T0VAL1 are read only. In 16-bit mode, 16-bit T0VAL0 is used. In 48-bit mode, both 16-bit T0VAL0 and 32-bit T0VAL1 are used.
T0ICLR	8-bit register. Writing any value to this register clears the interrupt. Available only in 16-bit mode.
T0CON	Configuration MMR.

Timer0 Value Registers

T0VAL0 and T0VAL1 are 16-bit and 32-bit registers that hold the 16 least significant bits and 32 most significant bits, respectively. T0VAL0 and T0VAL1 are read-only registers. In 16-bit mode, 16-bit T0VAL0 is used. In 48-bit mode, both 16-bit T0VAL0 and 32-bit T0VAL1 are used.

Name:	T0VAL0
Address:	0xFFFF0304
Default value:	0x0000
Access:	Read only
Name:	T0VAL1
Address:	0xFFFF0308
Default value:	0x00000000
Access:	Read only

Timer0 Capture Register

This is a 16-bit register that holds the 16-bit value captured by an enabled IRQ event; available in 16-bit mode only.

Name: TOCAP
 Address: 0xFFFF0314
 Default value: 0x0000
 Access: Read only

Timer0 Control Register

This 17-bit MMR configures the mode of operation of Timer0.

Name: T0CON
 Address: 0xFFFF030C
 Default value: 0x00000000
 Access: Read and write

Table 123. T0CON MMR Bit Designations

Bit	Value	Description
31:18		Reserved.
17		Event select bit. Set by the user to enable time capture of an event. Cleared by the user to disable time capture of an event.
16:12		Event select range, 0 to 16. The events are described in the introduction to the Timers section.
11		Reserved.
10:9	00 01 10 11	Clock select. Internal 32 kHz oscillator. UCLK. External 32 kHz crystal. HCLK.
8		Count up. Available in 16-bit mode only. Set by the user for Timer0 to count up. Cleared by the user for Timer0 to count down (default).
7		Timer0 enable bit. Set by the user to enable Timer0. Cleared by the user to disable Timer0 (default).
6		Timer0 mode. Set by the user to operate in periodic mode. Cleared by the user to operate in free-running mode (default).
5		Reserved.
4	0 1	Timer0 mode of operation. 16-bit operation (default). 48-bit operation.

Bit	Value	Description
3:0	0000 0100 1000 1111	Prescaler. Source clock divide-by-1 (default). Source clock divide-by-16. Source clock divide-by-256. Source clock divide-by-32,768.

Timer0 Load Registers

T0LD is a 16-bit register that holds the 16-bit value that is loaded into the counter; available only in 16-bit mode.

Name: T0LD
 Address: 0xFFFF0300
 Default value: 0x00
 Access: Read and write

Timer0 Clear Register

This 8-bit, write-only MMR is written (with any value) by user code to refresh (reload) Timer0.

Name: T0CLR
 Address: 0xFFFF0310
 Default value: 0x00
 Access: Write only

TIMER1—GENERAL-PURPOSE TIMER

Timer1 is a 32-bit general-purpose timer, count down or count up, with a programmable prescaler. The prescaler source can be from the 32 kHz internal oscillator, the 32 kHz external crystal, the core clock, or from the undivided PLL clock output. This source can be scaled by a factor of 1, 16, 256, or 32,768. This gives a minimum resolution of 22 ns when operating at CD zero, the core is operating at 41.78 MHz, and with a prescaler of one.

The counter can be formatted as a standard 32-bit value or as hours:minutes:seconds:hundreths.

Timer1 has a capture register (T1CAP) that can be triggered by a source initial assertion of a selected IRQ. When triggered, the current timer value is copied to T1CAP, and the timer keeps running. This feature can be used to determine the assertion of an event with increased accuracy. Timer1 interface consists of five MMRs as shown in Table 124.

If the part is in a low power mode and Timer1 is clocked from the GPIO or low power oscillator source, then Timer1 continues to operate.

Timer1 reloads the value from T1LD either when Timer1 overflows or immediately when T1ICLR is written.

Table 124. Timer1 Interface Registers

Register	Description
T1LD	32-bit register. Holds 32-bit unsigned integers. This register is read only.
T1VAL	32-bit register. Holds 32-bit unsigned integers.
T1CAP	32-bit register; Holds 32-bit unsigned integers. This register is read only.
T1CLRI	8-bit register. Writing any value to this register clears the Timer1 interrupt.
T1CON	Configuration MMR.

Timer1 Load Registers

T1LD is a 32-bit register that holds the 32-bit value that is loaded into the counter.

Name: T1LD
 Address: 0xFFFF0320
 Default value: 0x00000000
 Access: Read and write

Timer1 Clear Register

This 8-bit, write-only MMR is written (with any value) by user code to refresh (reload) Timer1.

Name: T1CLRI
 Address: 0xFFFF032C
 Default value: 0x00
 Access: Write only

Timer1 Value Register

T1VAL is a 32-bit register that holds the current value of Timer1.

Name: T1VAL
 Address: 0xFFFF0324
 Default value: 0x00000000
 Access: Read only

Timer1 Capture Register

This is a 32-bit register that holds the 32-bit value captured by an enabled IRQ event.

Name: T1CAP
 Address: 0xFFFF0330
 Default value: 0x0000
 Access: Read only

Timer1 Control Register

This 32-bit MMR configures the mode of operation of Timer1.

Name: T1CON
 Address: 0xFFFF0328
 Default value: 0x00000000
 Access: Read and write

Table 125. T1CON MMR Bit Designations

Bit	Value	Description
31:24		8-bit postscaler.
23		Enable write to postscaler.
22:20		Reserved.
19		Postscaler compare flag.
18		T1 interrupt generation selection flag.
17		Event select bit. Set by the user to enable time capture of an event. Cleared by the user to disable time capture of an event.
16:12		Event select range, 0 to 16. The events are as described in the introduction to the Timers section.
11:9	000 001 010 011	Clock select. Internal 32 kHz oscillator (default). Core clock. UCLK. P0.6. of the P0.6/MRST/PLAI[2] pin.
8		Count up. Set by the user for Timer1 to count up. Cleared by the user for Timer1 to count down (default).
7		Timer1 enable bit. Set by the user to enable Timer1. Cleared by the user to disable Timer1 (default).
6		Timer1 mode. Set by the user to operate in periodic mode. Cleared by the user to operate in free-running mode (default).
5:4	00 01 10 11	Format. Binary (default). Reserved. Hr:Min:Sec:Hundredths: 23 hours to 0 hour. Hr:Min:Sec:Hundredths: 255 hours to 0 hour.
3:0	0000 0100 1000 1111	Prescaler. Source clock divide-by-1 (default). Source clock divide-by-16. Source clock divide-by-256. Source clock divide-by-32,768.

TIMER2—WAKE-UP TIMER

Timer2 is a 32-bit wake-up timer, count down or count up, with a programmable prescaler. The prescaler is clocked directly from one of four clock sources, namely, the core clock (default selection), the internal 32.768 kHz oscillator, the external 32.768 kHz watch crystal, or the PLL undivided clock. The selected clock source can be scaled by a factor of 1, 16, 256, or 32,768. The wake-up timer continues to run when the core clock is disabled. This gives a minimum resolution of 22 ns when the core is operating at 41.78 MHz and with a prescaler of 1. Capture of the current timer value is enabled if the Timer2 interrupt is enabled via IRQEN[4].

The counter can be formatted as a plain 32-bit value or as Hours:Minutes:Seconds:Hundredths.

Timer2 reloads the value from T2LD either when Timer2 overflows or immediately when T2CLR1 is written. The Timer2 interface consists of four MMRs, as shown in Table 126.

Table 126. Timer2 Interface Registers

Register	Description
T2LD	32-bit register. Holds 32-bit unsigned integers.
T2VAL	32-bit register. Holds 32-bit unsigned integers. This register is read only.
T2CLR1	8-bit register. Writing any value to this register clears the Timer2 interrupt.
T2CON	Configuration MMR.

Timer2 Load Registers

T2LD is a 32-bit register, which holds the 32 bit value that is loaded into the counter.

Name: T2LD
 Address: 0xFFFF0340
 Default value: 0x00000000
 Access: Read and write

Timer2 Clear Register

This 8-bit write-only MMR is written (with any value) by the user code to refresh (reload) Timer2.

Name: T2CLR1
 Address: 0xFFFF034C
 Default value: 0x00
 Access: Write only

Timer2 Value Register

T2VAL is a 32-bit register that holds the current value of Timer2.

Name: T2VAL
 Address: 0xFFFF0344
 Default value: 0x00000000
 Access: Read only

Timer2 Control Register

This 32-bit MMR configures the mode of operation for Timer2.

Name: T2CON
 Address: 0xFFFF0348
 Default value: 0x00000000
 Access: Read and write

Table 127. T2CON MMR Bit Designations

Bit	Value	Description
31:11		Reserved.
10:9	00	Clock source select. Internal 32.768 kHz oscillator (default).
	01	Core clock.
	10	External 32.768kHz watch crystal.
	11	UCLK.
8		Count up. Set by the user for Timer2 to count up. Cleared by the user for Timer2 to count down (default).
7		Timer2 enable bit. Set by the user to enable Timer2. Cleared by the user to disable Timer2 (default).
6		Timer2 mode. Set by the user to operate in periodic mode. Cleared by the user to operate in free-running mode (default).
5:4	00	Format. Binary (default).
	01	Reserved.
	10	Hr:Min:Sec:Hundredths: 23 hours to 0 hour.
	11	Hr:Min:Sec:Hundredths: 255 hours to 0 hour.
3:0	0000	Prescaler. Source clock divide-by-1 (default).
	0100	Source clock divide-by-16.
	1000	Source clock divide-by-256. (Use this setting in conjunction with Timer2 Format 1,0 and Format 1,1.)
	1111	Source clock divide-by-32,768.

TIMER3—WATCHDOG TIMER

Figure 38. Timer3 Block Diagram

Timer3 has two modes of operation: normal mode and watchdog mode. The watchdog timer is used to recover from an illegal software state. When enabled, it requires periodic servicing to prevent it from forcing a reset of the processor.

Timer3 reloads the value from T3LD either when Timer3 overflows or immediately when T3CLRI is written.

Normal Mode

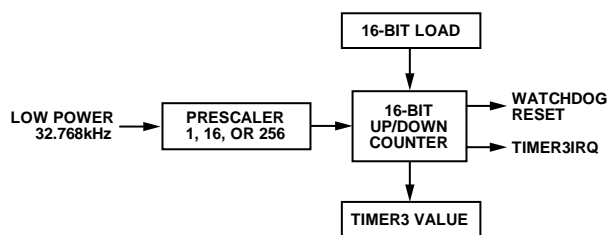
The Timer3 in normal mode is identical to Timer0 in 16-bit mode of operation, except for the clock source. The clock source is the 32.768 kHz oscillator and can be scaled by a factor of 1, 16, or 256. Timer3 also features a capture facility that allows capture of the current timer value if the Timer2 interrupt is enabled via IRQEN[5].

Watchdog Mode

Watchdog mode is entered by setting T3CON[5]. Timer3 decrements from the timeout value present in the T3LD register until 0. The maximum timeout is 512 seconds, using the maximum prescaler divide-by-256 and full scale in T3LD.

User software should only configure a minimum timeout period of 30 milliseconds. This is to avoid any conflict with Flash/EE memory page erase cycles, requiring 20 ms to complete a single page erase cycle and kernel execution.

If T3VAL reaches 0, a reset or an interrupt occurs, depending on T3CON[1]. To avoid a reset or an interrupt event, any value must be written to T3ICLR before T3VAL reaches zero. This reloads the counter with T3LD and begins a new timeout period.

Once watchdog mode is entered, T3LD and T3CON are write protected. These two registers cannot be modified until a power-on reset event resets the watchdog timer. After any other reset event, the watchdog timer continues to count. The watchdog timer should be configured in the initial lines of user code to avoid an infinite loop of watchdog resets.

Timer3 is automatically halted during JTAG debug access and only recommences counting once JTAG has relinquished control of the ARM7 core. By default, Timer3 continues to count during power-down. This can be disabled by setting Bit 0 in T3CON. It is recommended that the default value is used, that is, the watchdog timer continues to count during power-down.

Timer3 Interface

Timer3 interface consists of four MMRS as shown in Table 128.

Table 128. Timer3 Interface Registers

Register	Description
T3CON	The configuration MMR.
T3LD	6-bit register (Bit 0 to Bit15); holds 16-bit unsigned integers.
T3VAL	6-bit register (Bit 0 to Bit 15); holds 16-bit unsigned integers. This register is read only.
T3CLRI	8-bit register. Writing any value to this register clears the Timer3 interrupt in normal mode or resets a new timeout period in watchdog mode.

Timer3 Load Register

This 16-bit MMR holds the Timer3 reload value.

Name:	T3LD
Address:	0xFFFFF0360
Default value:	0x3BF8
Access:	Read and write

Timer3 Value Register

This 16-bit, read-only MMR holds the current Timer3 count value.

Name:	T3VAL
Address:	0xFFFFF0364
Default value:	0x3BF8
Access:	Read only

Timer3 Clear Register

This 8-bit, write-only MMR is written (with any value) by user code to refresh (reload) Timer3 in watchdog mode to prevent a watchdog timer reset event.

Name:	T3CLRI
Address:	0xFFFFF036C
Default value:	0x0000
Access:	Write only

Timer3 Control Register

The 16-bit MMR configures the mode of operation of Timer3 and is described in detail in Table 129.

Name:	T3CON
Address:	0xFFFFF0368
Default value:	0x00
Access:	Read and write one time only

Table 129. T3CON MMR Bit Designations

Bit	Value	Description
16:9		These bits are reserved and should be written as 0s by user code.
8		Count up/down enable. Set by user code to configure Timer3 to count up. Cleared by user code to configure Timer3 to count down.
7		Timer3 enable. Set by user code to enable Timer3. Cleared by user code to disable Timer3.
6		Timer3 operating mode. Set by user code to configure Timer3 to operate in periodic mode. Cleared by user to configure Timer3 to operate in free-running mode.
5		Watchdog timer mode enable. Set by user code to enable watchdog mode. Cleared by user code to disable watchdog mode.
4		Secure clear bit. Set by the user to use the secure clear option. Cleared by the user to disable the secure clear option by default.
3:2	00 01 10 11	Timer3 Clock(32.768 kHz) prescaler. Source clock divide-by-1 (default). Reserved. Reserved. Reserved.
1		Watchdog timer IRQ enable. Set by user code to produce an IRQ instead of a reset when the watchdog reaches 0. Cleared by user code to disable the IRQ option.
0		PD_OFF. Set by user code to stop Timer3 when the peripherals are powered down via Bit 4 in the POWCON MMR. Cleared by user code to enable Timer3 when the peripherals are powered down via Bit 4 in the POWCON MMR.

Secure Clear Bit (Watchdog Mode Only)

The secure clear bit is provided for a higher level of protection. When set, a specific sequential value must be written to T3CLRI to avoid a watchdog reset. The value is a sequence generated by the 8-bit linear feedback shift register (LFSR) polynomial = $X^8 + X^6 + X^5 + X + 1$.

The initial value or seed is written to T3CLRI before entering watchdog mode. After entering watchdog mode, a write to T3CLRI must match this expected value. If it matches, the LFSR is advanced to the next state when the counter reload happens. If it fails to match the expected state, reset is immediately generated, even if the count has not yet expired.

Because of the properties of the polynomial, do not use the value, 0x00, as an initial seed. Value 0x00 is always guaranteed to force an immediate reset. The value of the LFSR cannot be read; it must be tracked/generated in software.

Example of a sequence:

1. Enter initial seed, 0xAA, in T3CLRI before starting Timer3 in watchdog mode.
2. Enter 0xAA in T3CLRI; Timer3 is reloaded.
3. Enter 0x37 in T3CLRI; Timer3 is reloaded.
4. Enter 0x6E in T3CLRI; Timer3 is reloaded.
5. Enter 0x66. 0xDC was expected; the watchdog resets the chip.

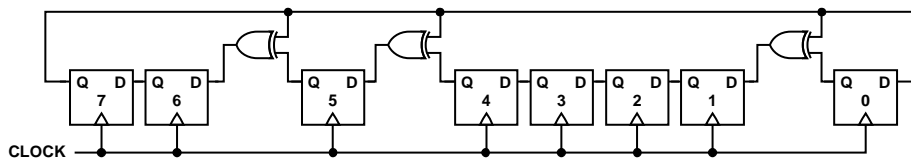

TIMER4—GENERAL-PURPOSE TIMER

Timer4 is a 32-bit general-purpose timer, count down or count up, with a programmable prescaler. The prescaler source can be the 32 kHz oscillator, the core clock, or PLL undivided output. This source can be scaled by a factor of 1, 16, 256, or 32,768. This gives a minimum resolution of 42 ns when operating at CD zero, the core is operating at 41.78 MHz, and with a prescaler of 1 (ignoring external GPIO).

The counter can be formatted as a standard 32-bit value or as hours:minutes:seconds:hundreths.

Timer4 has a capture register (T4CAP), which can be triggered by a selected IRQ's source initial assertion. Once triggered, the current timer value is copied to T4CAP, and the timer keeps running. This feature can be used to determine the assertion of an event with increased accuracy.

Timer4 interface consists of five MMRS.

- T4LD, T4VAL and T4CAP are 32-bit registers and hold 32-bit unsigned integers. T4VAL and T4CAP are read only.
- T4ICLR is an 8-bit register. Writing any value to this register clears the Timer1 interrupt.
- T4CON is the configuration MMR.
- Note that if the part is in a low power mode, and Timer4 is clocked from the GPIO or oscillator source then, Timer4 continues to operate.

Timer4 reloads the value from T4LD either when Timer4 overflows, or immediately when T4ICLR is written.

Timer4 Load Registers

T4LD is a 32-bit register, which holds the 32-bit value that is loaded into the counter.

Name: T4LD
 Address: 0xFFFF0380
 Default value: 0x00000000
 Access: Read and write

Timer4 Clear Register

This 8-bit, write-only MMR is written (with any value) by user code to refresh (reload) Timer4.

Name: T4CLR
 Address: 0xFFFF038C
 Default value: 0x00
 Access: Write only

Timer4 Value Register

T4VAL is a 32-bit register that holds the current value of Timer4.

Name: T4VAL
 Address: 0xFFFF0384
 Default value: 0x00000000
 Access: Read only

Timer4 Capture Register

This is a 32-bit register that holds the 32-bit value captured by an enabled IRQ event.

Name: T4CAP
 Address: 0xFFFF0390
 Default value: 0x00000000
 Access: Read only

Timer4 Control Register

This 32-bit MMR configures the mode of operation of Timer4.

Name: T4CON
 Address: 0xFFFF0388
 Default value: 0x0000
 Access: Read and write

ADuC7121

Table 130. T4CON MMR Bit Designations

Bit	Value	Description
31:18		Reserved. Set by the user to 0.
17		Event select bit. Set by the user to enable time capture of an event. Cleared by the user to disable time capture of an event.
16:12		Event select range, 0 to 31. The events are described in the introduction to the Timers section.
11:9		Clock select.
	000	32.768 kHz oscillator.
	001	HCLK (core clock).
	010	UCLK.
	011	UCLK.
8		Count up. Set by the user for Timer4 to count up. Cleared by the user for Timer4 to count down (default).
7		Timer4 enable bit. Set by the user to enable Timer4. Cleared by the user to disable Timer4 (default).
6		Timer4 mode. Set by the user to operate in periodic mode. Cleared by the user to operate in free-running mode (default).
5:4		Format.
	00	Binary (default).
	01	Reserved.
	10	Hr:Min:Sec:Hundredths: 23 hours to 0 hour.
	11	Hr:Min:Sec:Hundredths: 255 hours to 0 hour.
3:0		Prescaler.
	0000	Source clock divide-by-1 (default).
	0100	Source clock divide-by-16.
	1000	Source clock divide-by-256.
	1111	Source clock divide-by-32,768.

OUTLINE DIMENSIONS

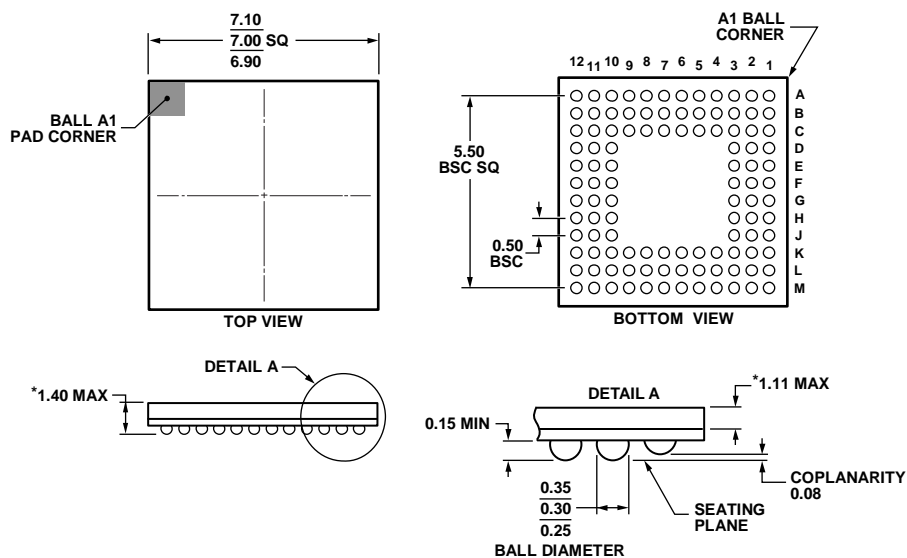

*COMPLIANT WITH JEDEC STANDARDS MO-195-BD WITH EXCEPTION TO PACKAGE HEIGHT AND THICKNESS.
 Figure 40. 108-Ball Chip Scale Package Ball Grid Array [CSP_BGA] (BC-108-4)
 Dimensions shown in millimeters

000408-A

ORDERING GUIDE

Model ¹	Temperature Range	Package Description	Package Option
ADuC7121BBCZ	-10°C to +95°C	108-Ball CSP_BGA	BC-108-4
ADuC7121BBCZ-RL	-10°C to +95°C	108-Ball CSP_BGA, 13" Tape and Reel	BC-108-4
EVAL-ADuC7121QSPZ		ADuC7121 QuickStart Development System	

¹ Z = RoHS Compliant Part.

NOTES

I²C refers to a communications protocol originally developed by Philips Semiconductors (now NXP Semiconductors).