

4

3

2

1

THIS DRAWING IS UNPUBLISHED. RELEASED FOR PUBLICATION. ALL RIGHTS RESERVED.

LOC		DIBT		REVISIONS			
P	LR	DESCRIPTION	DATE	BY	APPD		
M2		REVISED PER ECO-11-004820	11MAR11	RK	HMR		

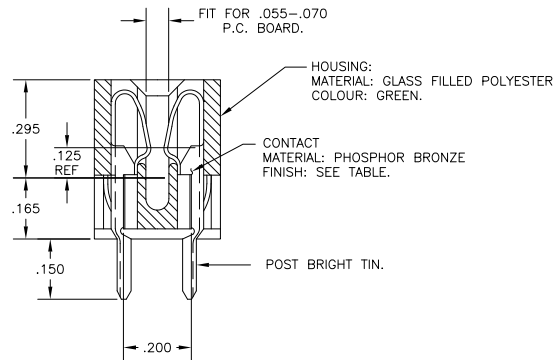
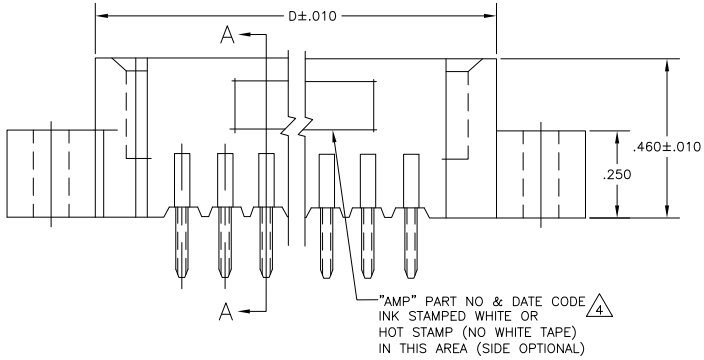
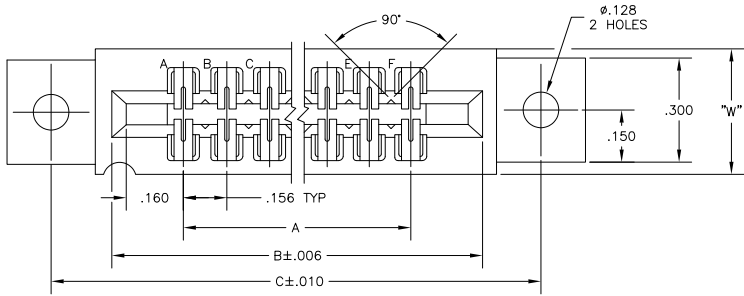

SECTION A-A

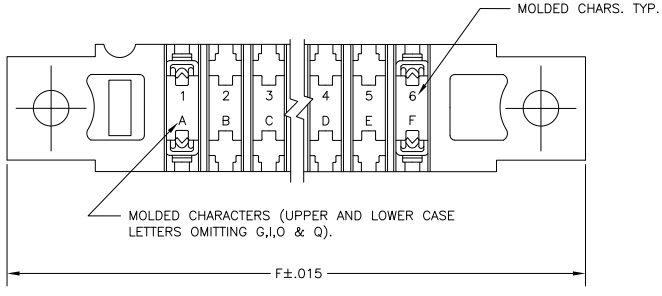

THIS DRAWING IS A CONTROLLED DOCUMENT.		DRN	19MAR75		TE Connectivity
		OK	20MAR75		
DIMENSIONS: INCHES		PRODUCT SPEC	NAME	HOUSING ASSY, LOW PROFILE, EDGE CONNECTOR, FLOW SOLDER, FOR .052 DIA. HOLE, .156X.200 CENTERS.	
TOLERANCES UNLESS OTHERWISE SPECIFIED:		APPLICATION SPEC	SIZE	A2 00779 C=530655	
Ø PLC ± .005		WEIGHT	RESTRICTED TO	—	
PLC ± .005		CUSTOMER DRAWING		SCALE	4:1
PLC ± .005				SHEET	1 of 2
PLC ± .005				REV	M2
ANGLES ± .5°					

4

3

2

1

THIS DRAWING IS UNPUBLISHED. RELEASED FOR PUBLICATION
 © COPYRIGHT - By - ALL RIGHTS RESERVED.

LOC	DIST	REVISIONS					
AD	00	P	LTR	DESCRIPTION	DATE	BY	APPD
		-	-	SEE SHEET 1	-	-	-

- ① .000015 MIN GOLD OVER .000050 MIN. NICKEL IN CONTACT AREA.
- ② .000030 MIN GOLD OVER .00005 MIN. NICKEL IN CONTACT AREA.
- ③ SELECTIVELY LOADED, OMIT CONTACTS IN CIRCUIT CAVITIES 14,16,18,S AND U
- ④ ALL PARTS ASSEMBLED IN MEXICO MUST BE STAMPED "ASSY IN MEXICO" THE WORD "MEXICO" CAN BE SUBSTITUTED ONLY WHERE PART SIZE PROHIBITS STAMPING "ASSY IN MEXICO", INK STAMP COLOUR WHITE OR HOT STAMP (NO WHITE TAPE) 115-9009, APPROX. WHERE SHOWN, SIDE OPTIONAL.
- ⑤ MATTE TIN PLATED CONTACT TAILS.
- ⑥ OBSOLETE PARTS: OBSOLETE CIS STREAMLINING PER D.RENAUD/D.SINISI

①	-	43	6.552	6.872	7.307	7.012	.437	7.557	①	8-530655-3
①	-	28	4.212	4.532	4.967	4.672	.370	5.217	①	8-530655-2
①	-	36	5.460	5.780	6.215	5.920	.437	6.465	①	8-530655-0
①	-	30	4.524	4.844	5.279	4.984	.437	5.529		7-530655-9
①	-	22	3.276	3.596	4.031	3.736	.370	4.281		7-530655-6
①	-	18	2.652	2.972	3.407	3.112	.370	3.657		7-530655-5
①	-	15	2.184	2.504	2.939	2.644	.370	3.189		7-530655-4
①	-	12	1.716	2.036	2.471	2.176	.370	2.721		7-530655-3
①	-	10	1.404	1.724	2.159	1.864	.370	2.409		7-530655-2
①	-	6	.780	1.100	1.535	1.240	.370	1.785		7-530655-1
①	-	18	2.652	2.972	3.407	3.112	.370	3.657		3-530655-4
	1-530655-3	43	6.552	6.872	7.307	7.012	.437	7.557		3-530655-3
	1-530655-2	28	4.212	4.532	4.967	4.672	.370	5.217		3-530655-2
	1-530655-1	44	6.708	7.028	7.463	7.168	.437	7.713		3-530655-1
	1-530655-0	36	5.460	5.780	6.215	5.920	.437	6.465		3-530655-0
	530655-9	30	4.524	4.844	5.279	4.984	.437	5.529	①	2-530655-9
	530655-8	25	3.744	4.064	4.499	4.204	.370	4.749		2-530655-8
	530655-7	24	3.588	3.908	4.343	4.048		4.593		2-530655-7
	530655-6	22	3.276	3.596	4.031	3.736		4.281		2-530655-6
	530655-5	18	2.652	2.972	3.407	3.112		3.657		2-530655-5
	530655-4	15	2.184	2.504	2.939	2.644		3.189		2-530655-4
	530655-3	12	1.716	2.036	2.471	2.176		2.721		2-530655-3
	530655-2	10	1.404	1.724	2.159	1.864		2.409		2-530655-2
	530655-1	6	.780	1.100	1.535	1.240		1.785		2-530655-1
①	PART NO	NO.OF. POSITION	A	B	C	D	W	F	②	PART NO

OBSOLETE

THIS DRAWING IS A CONTROLLED DOCUMENT.

DIMENSIONS: INCHES 	DIMENSIONS: MILLIMETERS 	DIM: 19MAR75 OK: 20MAR75 APVD: 20MAR75 NAME:	TE Connectivity HOUSING ASSY, LOW PROFILE, EDGE CONNECTOR, FLOW SOLDER, FOR .052 DIA. HOLE .156X.200 CTRS.
MATERIAL: SEE CALL-OUT	FINISH: SEE CALL-OUT	PRODUCT SPEC: - APPLICATION SPEC: - WEIGHT: -	SIZE: A2 CAGE CODE (MIL-STD-883C): 00779 C=530655 RESTRICTED TO: -
CUSTOMER DRAWING		SCALE: 1:1	SHEET: 2 of 2 REV: M2

530655

A