

LOC	DIST	REVISIONS				
P	LTR	DESCRIPTION	DATE	DWN	APVD	
GW	-	A	-	19APR2001	BL	KM

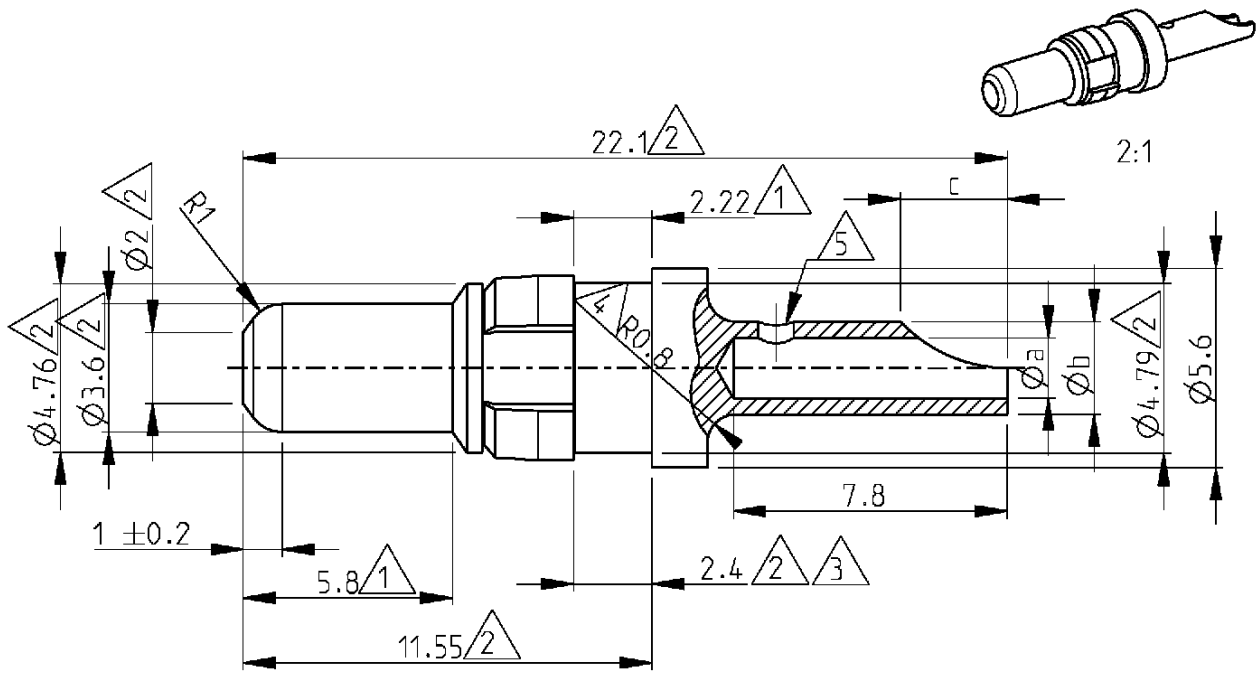

6) Application : DIN 41612 type M

- △5 Only on 1393589-5
- △4 Not applicable on 1393589-1
- △3 Measured with spring moved towards the mating face
- △2 max dimensions
- △1 Min dimensions

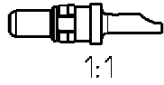

Cross reference							
Old part number	Tyco part number	Current	Øa	Øb	dim c	Material	Plating
C42334-A347-A93	1393589-5	10 A	1.7	2.6	3	Brass	1 µm Au or Pd in contact area
C42334-A347-A92	1393589-3	20 A	2.8	3.7	4	Brass	1 µm Au or Pd in contact area
C42334-A347-A91	1393589-1	40 A	4.8	5.6	5.2	Brass	1 µm Au or Pd in contact area

2000
 RELEASED FOR PUBLICATION
 THIS DRAWING IS UNPUBLISHED.
 COPYRIGHT 2000 BY TYCO ELECTRONICS CORPORATION. ALL RIGHTS RESERVED.

DIMENSIONS: mm		DWN B. Lenvain 19APR2001	MATERIAL -	FINISH -
TOLERANCES UNLESS OTHERWISE SPECIFIED:		CHK K. Mattheeuws 19APR2001	Tyco Electronics Oostkamp - Belgium	
0 PLC ±		APVD R. Leeman 19APR2001		
1 PLC ±		PRODUCT SPEC -	NAME High current plug with wire connection	
2 PLC ±		APPLICATION SPEC -	SIZE A4	CAGE CODE 00779
3 PLC ±		WEIGHT -	DRAWING NO C=1393589-5	RESTRICTED TO -
4 PLC ±				
ANGLES ±				
		CUSTOMER DRAWING		
			SCALE 5/1	SHEET 1 OF 1
				REV A