

THIS DRAWING IS UNPUBLISHED
 ALL RIGHTS RESERVED

REV	DATE	DESCRIPTION	BY	CHK	APP
00		REVISED PER EDD-11-004587			
01			11MMR11	RC	HMR

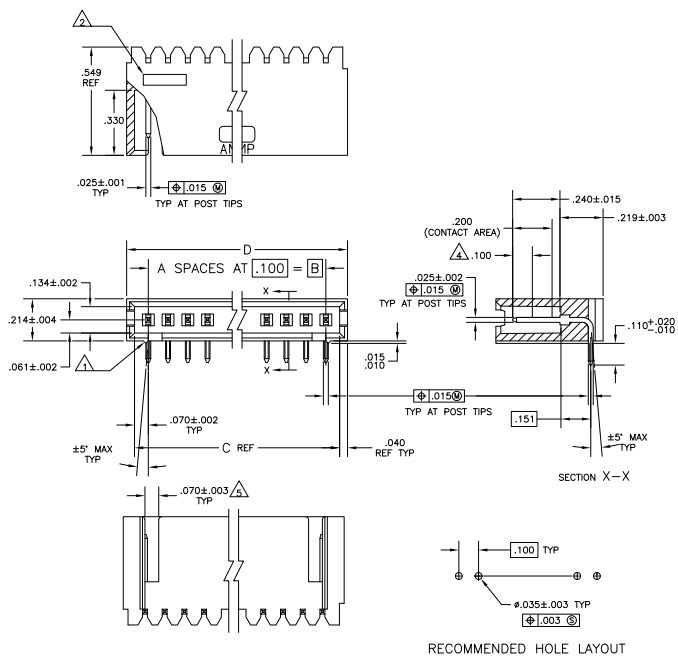

- △ STANDOFFS:
 3 THRU 9 POSN - (2 REOD) ON OUTSIDE ENDS OF HOUSING
 10 THRU 18 POSN - (3 REOD) TWO ON OUTSIDE ENDS AND ONE CENTERED ON HOUSING
 19 POSN AND LARGER - (4 REOD) TWO ON OUTSIDE ENDS AND TWO EVENLY SPACED WITHIN REMAINING LENGTH OF HOUSING
- △ RECESSED DATE CODE
- △ .000030 GOLD IN CONTACT AREA, .000100-.000200 MATTE TIN-LEAD IN SOLDER AREA, ALL OVER .000050 MIN NICKEL
- △ POINT OF MEASUREMENT FOR GOLD PLATING THICKNESS
- △ FOR 3 POS ONLY, ONE SLOT .215 WIDE.
- △ .000030 GOLD IN CONTACT AREA, .000100-.000200 MATTE TIN IN SOLDER AREA, ALL OVER .000050 MIN NICKEL
- △ OBSOLETE PARTS: OBSOLETE CIS STREAMLINING PER D.RENAUD/D.SINISI

REV	DATE	DESCRIPTION	BY	CHK	APP	
△ OBSOLETE	2.620	2.540	2.400	24	25	7-103361-3
△	2.520	2.440	2.300	23	24	7-103361-2
△	2.420	2.340	2.200	22	23	7-103361-1
OBSOLETE	2.320	2.240	2.100	21	22	7-103361-0
△	2.220	2.140	2.000	20	21	6-103361-9
△	2.120	2.040	1.900	19	20	6-103361-8
△	2.020	1.940	1.800	18	19	6-103361-7
OBSOLETE	1.920	1.840	1.700	17	18	6-103361-6
△	1.820	1.740	1.600	16	17	6-103361-5
△	1.720	1.640	1.500	15	16	6-103361-4
△	1.620	1.540	1.400	14	15	6-103361-3
OBSOLETE	1.520	1.440	1.300	13	14	6-103361-2
△	1.420	1.340	1.200	12	13	6-103361-1
OBSOLETE	1.220	1.140	1.000	10	11	6-103361-0
△	1.120	1.040	900	9	10	5-103361-8
△	1.020	940	800	8	9	5-103361-7
△	920	840	700	7	8	5-103361-6
△	820	740	600	6	7	5-103361-5
△	720	640	500	5	6	5-103361-4
△	620	540	400	4	5	5-103361-3
△	520	440	300	3	4	5-103361-2
△	420	340	200	2	3	5-103361-1
OBSOLETE	3.720	3.640	3.500	35	36	3-103361-4
OBSOLETE	3.620	3.540	3.400	34	35	3-103361-3
OBSOLETE	3.520	3.440	3.300	33	34	3-103361-2
OBSOLETE	3.420	3.340	3.200	32	33	3-103361-1
OBSOLETE	3.320	3.240	3.100	31	32	3-103361-0
OBSOLETE	3.220	3.140	3.000	30	31	2-103361-9
OBSOLETE	3.120	3.040	2.900	29	30	2-103361-8
OBSOLETE	3.020	2.940	2.800	28	29	2-103361-7
OBSOLETE	2.920	2.840	2.700	27	28	2-103361-6
OBSOLETE	2.820	2.740	2.600	26	27	2-103361-5
OBSOLETE	2.720	2.640	2.500	25	26	2-103361-4
OBSOLETE	2.620	2.540	2.400	24	25	2-103361-3
△	2.520	2.440	2.300	23	24	2-103361-2
OBSOLETE	2.420	2.340	2.200	22	23	2-103361-1
△	2.320	2.240	2.100	21	22	2-103361-0
OBSOLETE	2.220	2.140	2.000	20	21	1-103361-9
△	2.120	2.040	1.900	19	20	1-103361-8
△	2.020	1.940	1.800	18	19	1-103361-7
OBSOLETE	1.920	1.840	1.700	17	18	1-103361-6
△	1.820	1.740	1.600	16	17	1-103361-5
△	1.720	1.640	1.500	15	16	1-103361-4
△	1.620	1.540	1.400	14	15	1-103361-3
OBSOLETE	1.520	1.440	1.300	13	14	1-103361-2
△	1.420	1.340	1.200	12	13	1-103361-1
△	1.320	1.240	1.100	11	12	1-103361-0
OBSOLETE	1.220	1.140	1.000	10	11	1-103361-9
△	1.120	1.040	900	9	10	103361-8
△	1.020	940	800	8	9	103361-7
△	920	840	700	7	8	103361-6
△	820	740	600	6	7	103361-5
△	720	640	500	5	6	103361-4
△	620	540	400	4	5	103361-3
△	520	440	300	3	4	103361-2
△	420	340	200	2	3	103361-1

PLATING	D	C	B	A	NO. OF POSN.	PART NO.

THIS DRAWING IS A CONTROLLED DOCUMENT. THE SKETCH, DESIGN, OR MILL DRAWING IS THE AUTHORITY.

TE Connectivity
 TE CONNECTIVITY CORPORATION
 10000 WILSON AVENUE
 CHICAGO, IL 60654-0001
 USA

REVISIONS:
 1. 00779 (G)=103361

CUSTOMER DRAWING