

- NOTE:
- MATERIAL:
HOUSING: THERMOPLASTIC W/ 33% GF, UL 94V-0, COLOR: NATURAL.
CONTACTS: PHOSPHOR BRONZE.
 - FINISH:
CONTACTS: 120μ" MIN. MATTE-TIN OVER 50μ" MIN. NICKEL PLATED.
 - NO TYCO LOGO AND DATE CODE ON THE PRODUCT.

DIM. L	DIM. C	DIM. B	DIM. A	NO. OF CONTACTS	PART NUMBER
17.50	19.30	20.50	15	5	1734598-5
16.25	18.05	19.25	14	5	1734598-4
15.00	16.80	18.00	13	5	1734598-3
13.75	15.55	16.75	12	5	1734598-2
12.50	14.30	15.50	11	5	1734598-1
11.25	13.05	14.25	10	5	1734598-0
10.00	11.80	13.00	9	4	1734598-9
8.75	10.55	11.75	8	4	1734598-8
7.50	9.30	10.50	7	4	1734598-7
6.25	8.05	9.25	6	4	1734598-6
5.00	6.80	8.00	5	4	1734598-5
3.75	5.55	6.75	4	4	1734598-4
2.50	4.30	5.50	3	4	1734598-3
1.25	3.05	4.25	2	4	1734598-2
17.50	19.30	20.50	15	3	1734598-5
16.25	18.05	19.25	14	3	1734598-4
15.00	16.80	18.00	13	3	1734598-3
13.75	15.55	16.75	12	3	1734598-2
12.50	14.30	15.50	11	3	1734598-1
11.25	13.05	14.25	10	3	1734598-0
10.00	11.80	13.00	9	2	1734598-9
8.75	10.55	11.75	8	2	1734598-8
7.50	9.30	10.50	7	2	1734598-7
6.25	8.05	9.25	6	2	1734598-6
5.00	6.80	8.00	5	2	1734598-5
3.75	5.55	6.75	4	2	1734598-4
2.50	4.30	5.50	3	2	1734598-3
1.25	3.05	4.25	2	2	1734598-2
17.50	19.30	20.50	15	1	1734598-5
16.25	18.05	19.25	14	1	1734598-4
15.00	16.80	18.00	13	1	1734598-3
13.75	15.55	16.75	12	1	1734598-2
12.50	14.30	15.50	11	1	1734598-1
11.25	13.05	14.25	10	1	1734598-0
10.00	11.80	13.00	9	1	1734598-9
8.75	10.55	11.75	8	1	1734598-8
7.50	9.30	10.50	7	1	1734598-7
6.25	8.05	9.25	6	1	1734598-6
5.00	6.80	8.00	5	1	1734598-5
3.75	5.55	6.75	4	1	1734598-4
2.50	4.30	5.50	3	1	1734598-3
1.25	3.05	4.25	2	1	1734598-2

TOLERANCES UNLESS OTHERWISE SPECIFIED:		DWN	A. WU	TE Connectivity	
0 PLC ±		30-DEC-2005		NAME	
1 PLC ±0.38		S. HOU		1.25 MM PITCH WIRE TO BOARD	
2 PLC ±0.25		30-DEC-2005		CONNECTOR, HEADER, DIP, VERTICAL	
3 PLC ±		W.J. KE		REV	
ANGLES ±5°		30-DEC-2005		P	
MATERIAL	APVD	PRODUCT SPEC		SCALE	
SEE NOTE	108-57273	501-57299		A ₃	
FINISH	QUALIFICATION TEST REPORT	LOC		DRAWING NO	
SEE NOTE	501-57299	C-1734598		C-1734598	
WEIGHT		SCALE		SHEET	
-		--		1 OF 2	

P	REVISION RECORD	REVISED PER ECO-11-005301	RK HMR	APR11
LTR	REVISION RECORD	ECO	CHK	DATE

NUMBER C-1734598
 METRIC
 3RD ANGLE PROJECTION

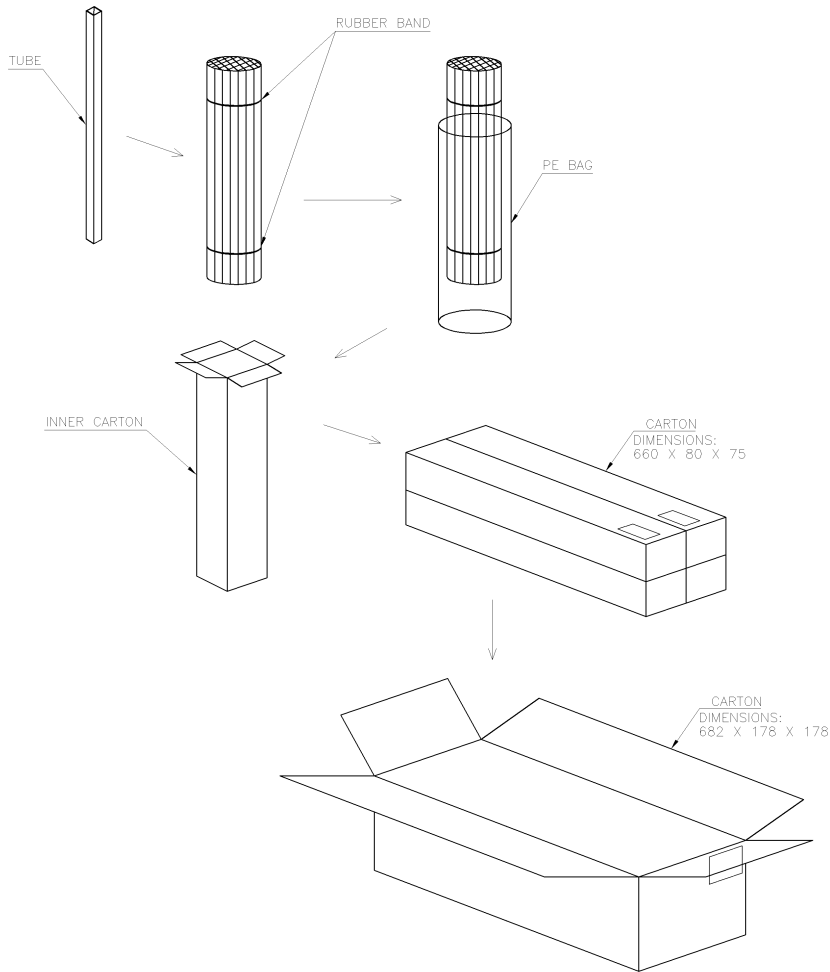

200	6000	30	5.948	2.178	15
	6400	32	5.920	2.150	14
	6800	34	5.919	2.148	13
	7200	36	5.959	2.188	12
	7800	39	5.868	2.098	11
	8600	43	5.972	2.201	10
	9400	47	5.970	2.199	9
	10400	52	5.954	2.184	8
	11600	58	5.974	2.204	7
	13200	66	5.850	2.112	6
15200	76	5.929	2.158	5	
18000	90	5.930	2.160	4	
22000	110	5.950	2.178	3	
28200	141	5.915	2.143	2	

TUBES/ CARTON	QUANTITY	PCS/ TUBE	G/W (KG)	N/W (KG)	NO. OF CONTACTS
------------------	----------	--------------	-------------	-------------	--------------------

TOLERANCES UNLESS OTHERWISE SPECIFIED:		DWN	A. WU		
0 PLC ±		30-DEC-2005			
1 PLC ±		CHK	S. HOU	NAME 1.25 MM PITCH WIRE TO BOARD CONNECTOR, HEADER, DIP, VERTICAL	
2 PLC ±		30-DEC-2005			
3 PLC ±		APVD	W.J. KE	LOC SIZE DRAWING NO DW A ₃ C-1734598 REV P	
ANGLES ±		30-DEC-2005			
MATERIAL	-	PRODUCT SPEC	-	SCALE	2 OF 2
FINISH	-	APPLICATION SPEC	-	SHEET	
WEIGHT	-				

LTR	REVISION RECORD	SEE SHEET 1.	ECO	DWN/CHK	DATE
-----	-----------------	--------------	-----	---------	------

PRINT DIST
 DW
 DIMENSIONS IN MILLIMETERS. DO NOT SCALE PRINT.

CUSTOMER DRAWING