

Features

- High-performance, Low-power 32-bit Atmel® AVR® Microcontroller
 - Compact Single-cycle RISC Instruction Set including DSP Instructions
 - Read-modify-write Instructions and Atomic Bit Manipulation
 - Performance
 - Up to 64DMIPS Running at 50MHz from Flash (1 Flash Wait State)
 - Up to 36DMIPS Running at 25MHz from Flash (0 Flash Wait State)
 - Memory Protection Unit (MPU)
 - Secure Access Unit (SAU) providing User-defined Peripheral Protection
- picoPower® Technology for Ultra-low Power Consumption
- Multi-hierarchy Bus System
 - High-performance Data Transfers on Separate Buses for Increased Performance
 - 12 Peripheral DMA Channels improve Speed for Peripheral Communication
- Internal High-speed Flash
 - 256Kbytes, 128Kbytes, and 64Kbytes Versions
 - Single-cycle Access up to 25MHz
 - FlashVault Technology Allows Pre-programmed Secure Library Support for End User Applications
 - Prefetch Buffer Optimizing Instruction Execution at Maximum Speed
 - 100,000 Write Cycles, 15-year Data Retention Capability
 - Flash Security Locks and User-defined Configuration Area
- Internal High-speed SRAM, Single-cycle Access at Full Speed
 - 32Kbytes (256Kbytes and 128Kbytes Flash) and 16Kbytes (64Kbytes Flash)
- Interrupt Controller (INTC)
 - Autovectorized Low-latency Interrupt Service with Programmable Priority
- External Interrupt Controller (EIC)
- Peripheral Event System for Direct Peripheral to Peripheral Communication
- System Functions
 - Power and Clock Manager
 - SleepWalking Power Saving Control
 - Internal System RC Oscillator (RCSYS)
 - 32 KHz Oscillator
 - Multipurpose Oscillator, Phase Locked Loop (PLL), and Digital Frequency Locked Loop (DFLL)
- Windowed Watchdog Timer (WDT)
- Asynchronous Timer (AST) with Real-time Clock Capability
 - Counter or Calendar Mode Supported
- Frequency Meter (FREQM) for Accurate Measuring of Clock Frequency
- Universal Serial Bus (USBC)
 - Full Speed and Low Speed USB Device Support
 - Multi-packet Ping-pong Mode
- Six 16-bit Timer/Counter (TC) Channels
 - External Clock Inputs, PWM, Capture, and Various Counting Capabilities
- 36 PWM Channels (PWMA)
 - 12-bit PWM with a Source Clock up to 150MHz
- Four Universal Synchronous/Asynchronous Receiver/Transmitters (USART)
 - Independent Baudrate Generator, Support for SPI Interfaces
 - Support for Hardware Handshaking



32-bit Atmel AVR Microcontroller

ATUC256L3U
ATUC128L3U
ATUC64L3U
ATUC256L4U
ATUC128L4U
ATUC64L4U

Summary



- **One Master/Slave Serial Peripheral Interface (SPI) with Chip Select Signals**
 - Up to 15 SPI Slaves can be Addressed
- **Two Master and Two Slave Two-wire Interfaces (TWI), 400kbit/s I²C-compatible**
- **One 8-channel Analog-to-digital Converter (ADCIFB) with up to 12 Bits Resolution**
 - Internal Temperature Sensor
- **Eight Analog Comparators (ACIFB) with Optional Window Detection**
- **Capacitive Touch (CAT) Module**
 - Hardware-assisted Atmel[®] AVR[®] QTouch[®] and Atmel[®] AVR[®] QMatrix Touch Acquisition
 - Supports QTouch and QMatrix Capture from Capacitive Touch Sensors
- **QTouch Library Support**
 - Capacitive Touch Buttons, Sliders, and Wheels
 - QTouch and QMatrix Acquisition
- **Audio Bitstream DAC (ABDACB) Suitable for Stereo Audio**
- **Inter-IC Sound (IIS) Controller**
 - Compliant with Inter-IC Sound (I²S) Specification
- **On-chip Non-intrusive Debug System**
 - Nexus Class 2+, Runtime Control, Non-intrusive Data and Program Trace
 - aWire Single-pin Programming Trace and Debug Interface, Muxed with Reset Pin
 - NanoTrace Provides Trace Capabilities through JTAG or aWire Interface
- **64-pin TQFP/QFN (51 GPIO Pins), 48-pin TQFP/QFN/TLLGA (36 GPIO Pins)**
- **Six High-drive I/O Pins (64-pin Packages), Four High-drive I/O Pins (48-pin Packages)**
- **Single 1.62-3.6V Power Supply**

1. Description

The Atmel® AVR® ATUC64/128/256L3/4U is a complete system-on-chip microcontroller based on the AVR32 UC RISC processor running at frequencies up to 50MHz. AVR32 UC is a high-performance 32-bit RISC microprocessor core, designed for cost-sensitive embedded applications, with particular emphasis on low power consumption, high code density, and high performance.

The processor implements a Memory Protection Unit (MPU) and a fast and flexible interrupt controller for supporting modern and real-time operating systems. The Secure Access Unit (SAU) is used together with the MPU to provide the required security and integrity.

Higher computation capability is achieved using a rich set of DSP instructions.

The ATUC64/128/256L3/4U embeds state-of-the-art picoPower technology for ultra-low power consumption. Combined power control techniques are used to bring active current consumption down to 174µA/MHz, and leakage down to 220nA while still retaining a bank of backup registers. The device allows a wide range of trade-offs between functionality and power consumption, giving the user the ability to reach the lowest possible power consumption with the feature set required for the application.

The Peripheral Direct Memory Access (DMA) controller enables data transfers between peripherals and memories without processor involvement. The Peripheral DMA controller drastically reduces processing overhead when transferring continuous and large data streams.

The ATUC64/128/256L3/4U incorporates on-chip Flash and SRAM memories for secure and fast access. The FlashVault technology allows secure libraries to be programmed into the device. The secure libraries can be executed while the CPU is in Secure State, but not read by non-secure software in the device. The device can thus be shipped to end customers, who will be able to program their own code into the device to access the secure libraries, but without risk of compromising the proprietary secure code.

The External Interrupt Controller (EIC) allows pins to be configured as external interrupts. Each external interrupt has its own interrupt request and can be individually masked.

The Peripheral Event System allows peripherals to receive, react to, and send peripheral events without CPU intervention. Asynchronous interrupts allow advanced peripheral operation in low power sleep modes.

The Power Manager (PM) improves design flexibility and security. The Power Manager supports SleepWalking functionality, by which a module can be selectively activated based on peripheral events, even in sleep modes where the module clock is stopped. Power monitoring is supported by on-chip Power-on Reset (POR), Brown-out Detector (BOD), and Supply Monitor (SM). The device features several oscillators, such as Phase Locked Loop (PLL), Digital Frequency Locked Loop (DFLL), Oscillator 0 (OSC0), and system RC oscillator (RCSYS). Either of these oscillators can be used as source for the system clock. The DFLL is a programmable internal oscillator from 40 to 150MHz. It can be tuned to a high accuracy if an accurate reference clock is running, e.g. the 32KHz crystal oscillator.

The Watchdog Timer (WDT) will reset the device unless it is periodically serviced by the software. This allows the device to recover from a condition that has caused the system to be unstable.

The Asynchronous Timer (AST) combined with the 32KHz crystal oscillator supports powerful real-time clock capabilities, with a maximum timeout of up to 136 years. The AST can operate in counter or calendar mode.

The Frequency Meter (FREQM) allows accurate measuring of a clock frequency by comparing it to a known reference clock.

The Full-speed USB 2.0 device interface (USBC) supports several USB classes at the same time, thanks to the rich end-point configuration.

The device includes six identical 16-bit Timer/Counter (TC) channels. Each channel can be independently programmed to perform frequency measurement, event counting, interval measurement, pulse generation, delay timing, and pulse width modulation.

The Pulse Width Modulation controller (PWMA) provides 12-bit PWM channels which can be synchronized and controlled from a common timer. 36 PWM channels are available, enabling applications that require multiple PWM outputs, such as LCD backlight control. The PWM channels can operate independently, with duty cycles set individually, or in interlinked mode, with multiple channels changed at the same time.

The ATUC64/128/256L3/4U also features many communication interfaces, like USART, SPI, and TWI, for communication intensive applications. The USART supports different communication modes, like SPI Mode and LIN Mode.

A general purpose 8-channel ADC is provided, as well as eight analog comparators (ACIFB). The ADC can operate in 10-bit mode at full speed or in enhanced mode at reduced speed, offering up to 12-bit resolution. The ADC also provides an internal temperature sensor input channel. The analog comparators can be paired to detect when the sensing voltage is within or outside the defined reference window.

The Capacitive Touch (CAT) module senses touch on external capacitive touch sensors, using the QTouch technology. Capacitive touch sensors use no external mechanical components, unlike normal push buttons, and therefore demand less maintenance in the user application. The CAT module allows up to 17 touch sensors, or up to 16 by 8 matrix sensors to be interfaced. All touch sensors can be configured to operate autonomously without software interaction, allowing wakeup from sleep modes when activated.

Atmel offers the QTouch Library for embedding capacitive touch buttons, sliders, and wheels functionality into AVR microcontrollers. The patented charge-transfer signal acquisition offers robust sensing and includes fully debounced reporting of touch keys as well as Adjacent Key Suppression® (AKS®) technology for unambiguous detection of key events. The easy-to-use QTouch Suite toolchain allows you to explore, develop, and debug your own touch applications.

The Audio Bitstream DAC (ABDACB) converts a 16-bit sample value to a digital bitstream with an average value proportional to the sample value. Two channels are supported, making the ABDAC particularly suitable for stereo audio.

The Inter-IC Sound Controller (IISC) provides a 5-bit wide, bidirectional, synchronous, digital audio link with external audio devices. The controller is compliant with the Inter-IC Sound (I2S) bus specification.

The ATUC64/128/256L3/4U integrates a class 2+ Nexus 2.0 On-chip Debug (OCD) System, with non-intrusive real-time trace and full-speed read/write memory access, in addition to basic runtime control. The NanoTrace interface enables trace feature for aWire- or JTAG-based debuggers. The single-pin aWire interface allows all features available through the JTAG interface to be accessed through the RESET pin, allowing the JTAG pins to be used for GPIO or peripherals.

2. Overview

2.1 Block Diagram

Figure 2-1. Block Diagram

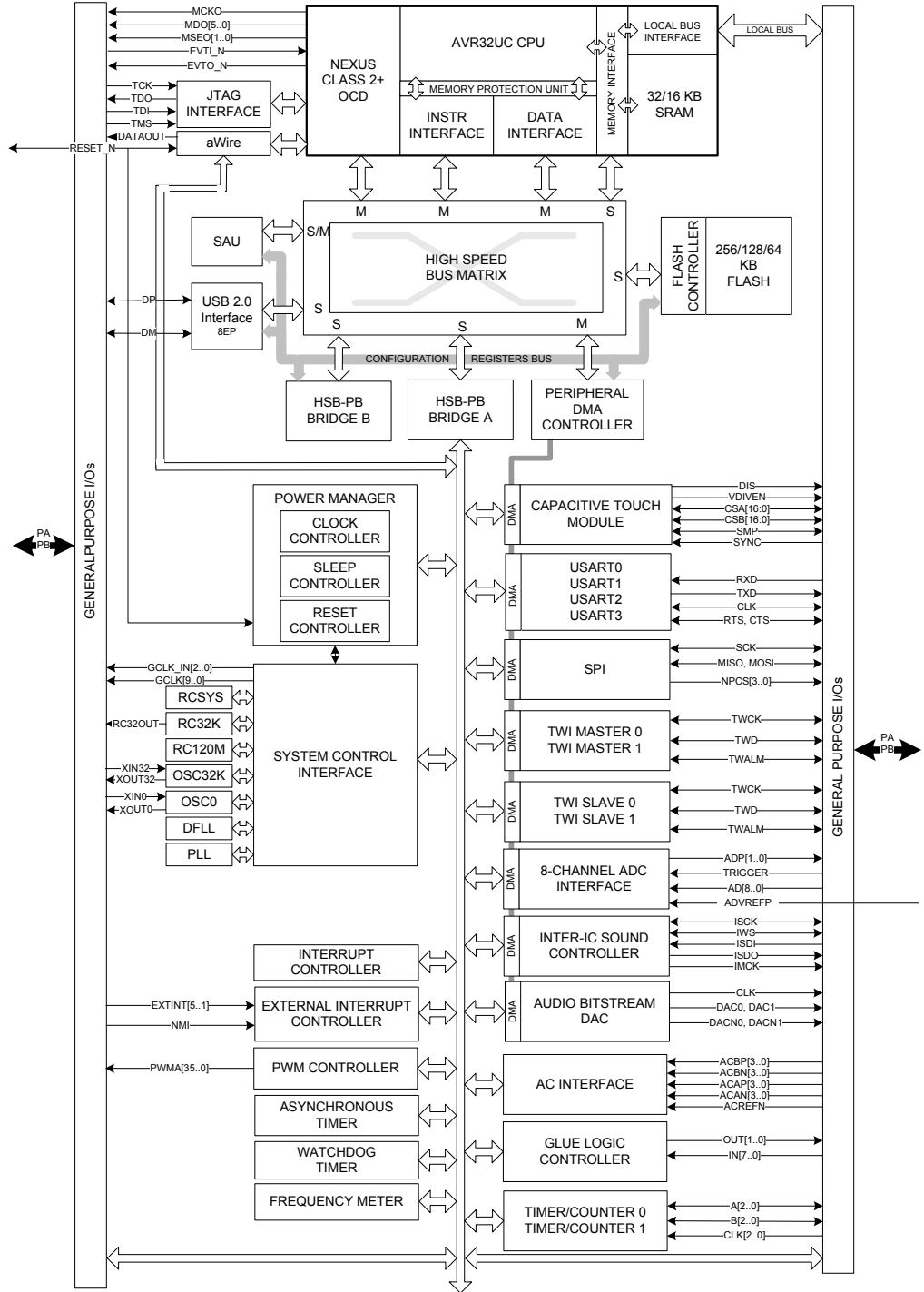

2.2 Configuration Summary

Table 2-1. Configuration Summary

Feature	ATUC256L3U	ATUC128L3U	ATUC64L3U	ATUC256L4U	ATUC128L4U	ATUC64L4U
Flash	256KB	128KB	64KB	256KB	128KB	64KB
SRAM	32KB		16KB	32KB		16KB
GPIO	51			36		
High-drive pins	6			4		
External Interrupts	6					
TWI	2					
USART	4					
Peripheral DMA Channels	12					
Peripheral Event System	1					
SPI	1					
Asynchronous Timers	1					
Timer/Counter Channels	6					
PWM channels	36					
Frequency Meter	1					
Watchdog Timer	1					
Power Manager	1					
Secure Access Unit	1					
Glue Logic Controller	1					
Oscillators	Digital Frequency Locked Loop 20-150MHz (DFLL) Phase Locked Loop 40-240MHz (PLL) Crystal Oscillator 0.45-16MHz (OSC0) Crystal Oscillator 32KHz (OSC32K) RC Oscillator 120MHz (RC120M) RC Oscillator 115kHz (RCSYS) RC Oscillator 32kHz (RC32K)					
ADC	8-channel 12-bit					
Temperature Sensor	1					
Analog Comparators	8					
Capacitive Touch Module	1					
JTAG	1					
aWire	1					
USB	1					
Audio Bitstream DAC	1			0		
IIS Controller	1			0		
Max Frequency	50MHz					
Packages	TQFP64/QFN64			TQFP48/QFN48/TLLGA48		

3. Package and Pinout

3.1 Package

The device pins are multiplexed with peripheral functions as described in [Section 3.2](#).

Figure 3-1. ATUC64/128/256L4U TQFP48/QFN48 Pinout

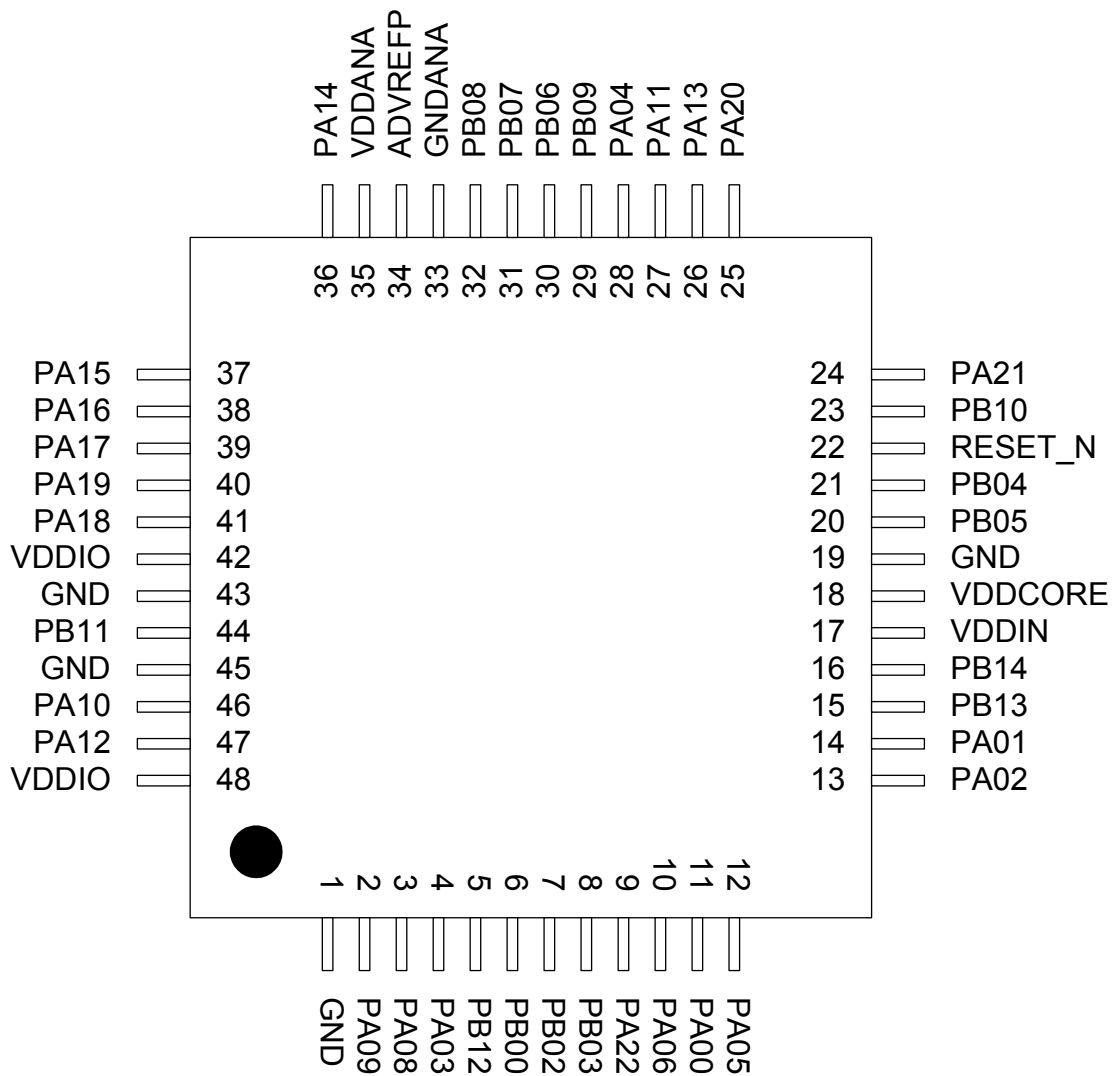

Figure 3-2. ATUC64/128/256L4U TLLGA48 Pinout

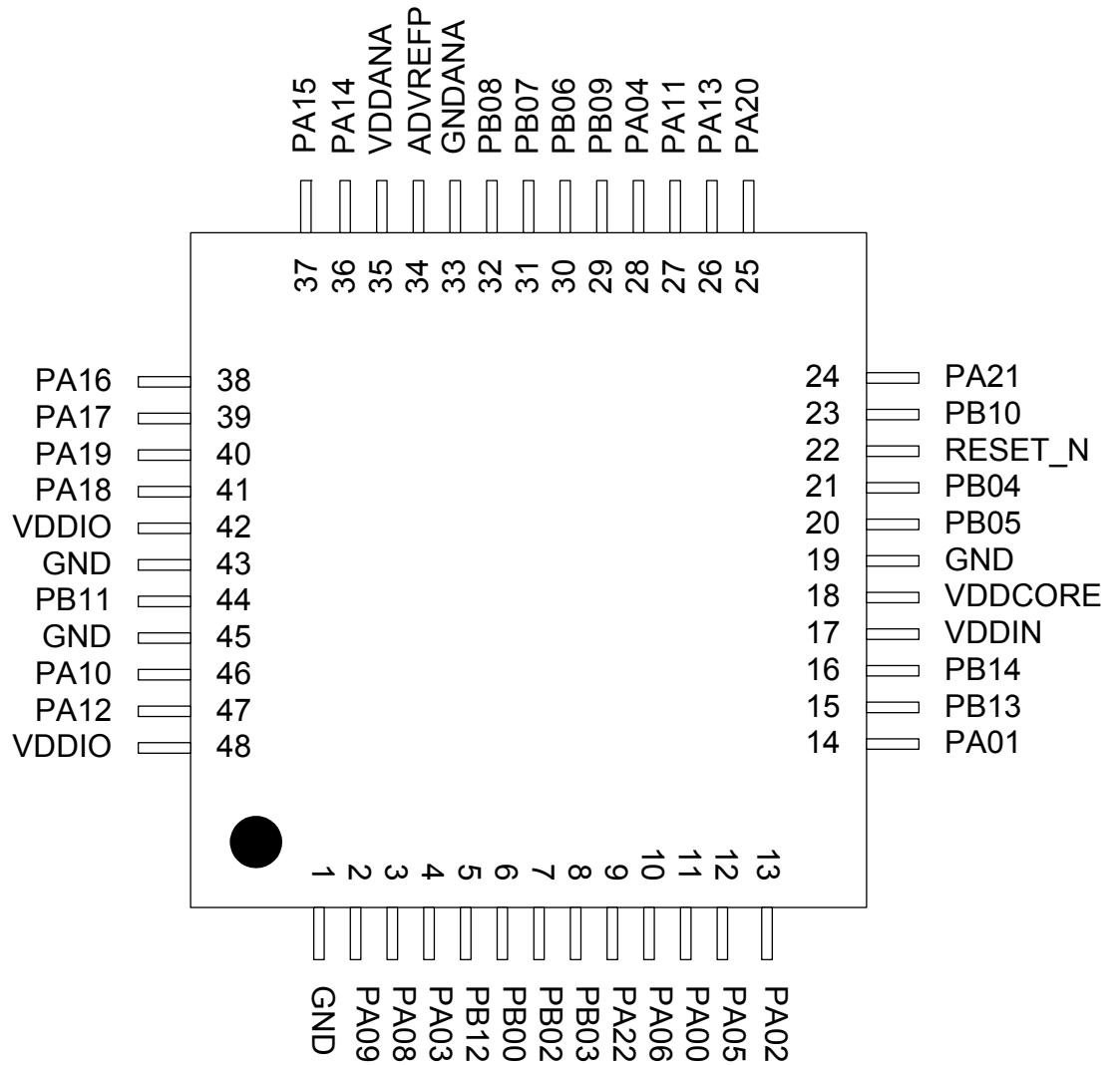
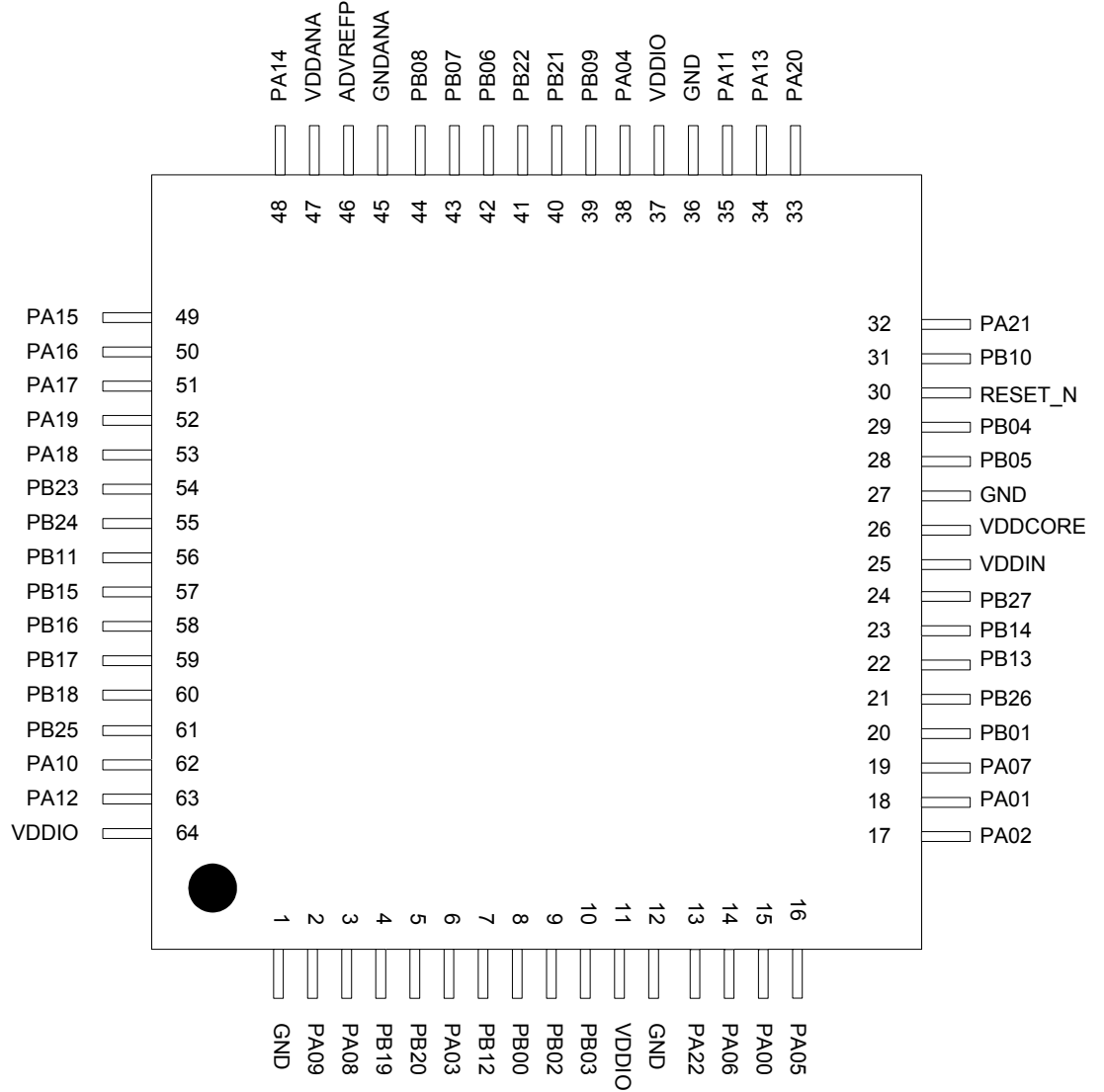

Figure 3-3. ATUC64/128/256L3U TQFP64/QFN64 Pinout



3.2 Peripheral Multiplexing on I/O lines

3.2.1 Multiplexed Signals

Each GPIO line can be assigned to one of the peripheral functions. The following table describes the peripheral signals multiplexed to the GPIO lines.

Table 3-1. GPIO Controller Function Multiplexing

48-pin	64-pin	Pin Name	GPIO	Supply	Pad Type	GPIO Function							
						A	B	C	D	E	F	G	H
11	15	PA00	0	VDDIO	Normal I/O	USART0-TXD	USART1-RTS	SPI-NPCS[2]		PWMA-PWMA[0]		SCIF-GCLK[0]	CAT-CSA[2]
14	18	PA01	1	VDDIO	Normal I/O	USART0-RXD	USART1-CTS	SPI-NPCS[3]	USART1-CLK	PWMA-PWMA[1]	ACIFB-ACAP[0]	TWIMS0-TWALM	CAT-CSA[1]
13	17	PA02	2	VDDIO	High-drive I/O	USART0-RTS	ADCIFB-TRIGGER	USART2-TXD	TC0-A0	PWMA-PWMA[2]	ACIFB-ACBP[0]	USART0-CLK	CAT-CSA[3]
4	6	PA03	3	VDDIO	Normal I/O	USART0-CTS	SPI-NPCS[1]	USART2-TXD	TC0-B0	PWMA-PWMA[3]	ACIFB-ACBN[3]	USART0-CLK	CAT-CSB[3]
28	38	PA04	4	VDDIO	Normal I/O	SPI-MISO	TWIMS0-TWCK	USART1-RXD	TC0-B1	PWMA-PWMA[4]	ACIFB-ACBP[1]		CAT-CSA[7]
12	16	PA05	5	VDDIO	Normal I/O (TWI)	SPI-MOSI	TWIMS1-TWCK	USART1-TXD	TC0-A1	PWMA-PWMA[5]	ACIFB-ACBN[0]	TWIMS0-TWD	CAT-CSB[7]
10	14	PA06	6	VDDIO	High-drive I/O, 5V tolerant	SPI-SCK	USART2-TXD	USART1-CLK	TC0-B0	PWMA-PWMA[6]	EIC-EXTINT[2]	SCIF-GCLK[1]	CAT-CSB[1]
	19	PA07	7	VDDIO	Normal I/O (TWI)	SPI-NPCS[0]	USART2-RXD	TWIMS1-TWALM	TWIMS0-TWCK	PWMA-PWMA[7]	ACIFB-ACAN[0]	EIC-EXTINT[0]	CAT-CSB[2]
3	3	PA08	8	VDDIO	High-drive I/O	USART1-TXD	SPI-NPCS[2]	TC0-A2	ADCIFB-ADP[0]	PWMA-PWMA[8]			CAT-CSA[4]
2	2	PA09	9	VDDIO	High-drive I/O	USART1-RXD	SPI-NPCS[3]	TC0-B2	ADCIFB-ADP[1]	PWMA-PWMA[9]	SCIF-GCLK[2]	EIC-EXTINT[1]	CAT-CSB[4]
46	62	PA10	10	VDDIO	Normal I/O	TWIMS0-TWD		TC0-A0		PWMA-PWMA[10]	ACIFB-ACAP[1]	SCIF-GCLK[2]	CAT-CSA[5]
27	35	PA11	11	VDDIN	Normal I/O					PWMA-PWMA[11]			
47	63	PA12	12	VDDIO	Normal I/O		USART2-CLK	TC0-CLK1	CAT-SMP	PWMA-PWMA[12]	ACIFB-ACAN[1]	SCIF-GCLK[3]	CAT-CSB[5]
26	34	PA13	13	VDDIN	Normal I/O	GLOC-OUT[0]	GLOC-IN[7]	TC0-A0	SCIF-GCLK[2]	PWMA-PWMA[13]	CAT-SMP	EIC-EXTINT[2]	CAT-CSA[0]
36	48	PA14	14	VDDIO	Normal I/O	ADCIFB-AD[0]	TC0-CLK2	USART2-RTS	CAT-SMP	PWMA-PWMA[14]		SCIF-GCLK[4]	CAT-CSA[6]
37	49	PA15	15	VDDIO	Normal I/O	ADCIFB-AD[1]	TC0-CLK1		GLOC-IN[6]	PWMA-PWMA[15]	CAT-SYNC	EIC-EXTINT[3]	CAT-CSB[6]
38	50	PA16	16	VDDIO	Normal I/O	ADCIFB-AD[2]	TC0-CLK0		GLOC-IN[5]	PWMA-PWMA[16]	ACIFB-ACREFN	EIC-EXTINT[4]	CAT-CSA[8]

Table 3-1. GPIO Controller Function Multiplexing

39	51	PA17	17	VDDIO	Normal I/O (TWI)		TC0-A1	USART2-CTS	TWIMS1-TWD	PWMA-PWMA[17]	CAT-SMP	CAT-DIS	CAT-CSB[8]	
41	53	PA18	18	VDDIO	Normal I/O	ADCIFB-AD[4]	TC0-B1		GLOC-IN[4]	PWMA-PWMA[18]	CAT-SYNC	EIC-EXTINT[5]	CAT-CSB[0]	
40	52	PA19	19	VDDIO	Normal I/O	ADCIFB-AD[5]		TC0-A2	TWIMS1-TWALM	PWMA-PWMA[19]	SCIF-GCLK_IN[0]	CAT-SYNC	CAT-CSA[10]	
25	33	PA20	20	VDDIN	Normal I/O	USART2-TXD		TC0-A1	GLOC-IN[3]	PWMA-PWMA[20]	SCIF-RC32OUT		CAT-CSA[12]	
24	32	PA21	21	VDDIN	Normal I/O (TWI, 5V tolerant, SMBus)	USART2-RXD	TWIMS0-TWD	TC0-B1	ADCIFB-TRIGGER	PWMA-PWMA[21]	PWMA-PWMAOD[21]	SCIF-GCLK[0]	CAT-SMP	
9	13	PA22	22	VDDIO	Normal I/O	USART0-CTS	USART2-CLK	TC0-B2	CAT-SMP	PWMA-PWMA[22]	ACIFB-ACBN[2]		CAT-CSB[10]	
6	8	PB00	32	VDDIO	Normal I/O	USART3-TXD	ADCIFB-ADP[0]		SPI-NPCS[0]	TC0-A1	PWMA-PWMA[23]	ACIFB-ACAP[2]	TC1-A0	CAT-CSA[9]
	20	PB01	33	VDDIO	High-drive I/O	USART3-RXD	ADCIFB-ADP[1]		SPI-SCK	TC0-B1	PWMA-PWMA[24]		TC1-A1	CAT-CSB[9]
7	9	PB02	34	VDDIO	Normal I/O	USART3-RTS	USART3-CLK		SPI-MISO	TC0-A2	PWMA-PWMA[25]	ACIFB-ACAN[2]	SCIF-GCLK[1]	CAT-CSB[11]
8	10	PB03	35	VDDIO	Normal I/O	USART3-CTS	USART3-CLK		SPI-MOSI	TC0-B2	PWMA-PWMA[26]	ACIFB-ACBP[2]	TC1-A2	CAT-CSA[11]
21	29	PB04	36	VDDIN	Normal I/O (TWI, 5V tolerant, SMBus)		TC1-A0	USART1-RTS	USART1-CLK	TWIMS0-TWALM	PWMA-PWMA[27]	PWMA-PWMAOD[27]	TWIMS1-TWCK	CAT-CSA[14]
20	28	PB05	37	VDDIN	Normal I/O (TWI, 5V tolerant, SMBus)		TC1-B0	USART1-CTS	USART1-CLK	TWIMS0-TWCK	PWMA-PWMA[28]	PWMA-PWMAOD[28]	SCIF-GCLK[3]	CAT-CSB[14]
30	42	PB06	38	VDDIO	Normal I/O		TC1-A1	USART3-TXD	ADCIFB-AD[6]	GLOC-IN[2]	PWMA-PWMA[29]	ACIFB-ACAN[3]	EIC-EXTINT[0]	CAT-CSB[13]
31	43	PB07	39	VDDIO	Normal I/O		TC1-B1	USART3-RXD	ADCIFB-AD[7]	GLOC-IN[1]	PWMA-PWMA[30]	ACIFB-ACAP[3]	EIC-EXTINT[1]	CAT-CSA[13]
32	44	PB08	40	VDDIO	Normal I/O		TC1-A2	USART3-RTS	ADCIFB-AD[8]	GLOC-IN[0]	PWMA-PWMA[31]	CAT-SYNC	EIC-EXTINT[2]	CAT-CSB[12]
29	39	PB09	41	VDDIO	Normal I/O		TC1-B2	USART3-CTS	USART3-CLK		PWMA-PWMA[32]	ACIFB-ACBN[1]	EIC-EXTINT[3]	CAT-CSB[15]
23	31	PB10	42	VDDIN	Normal I/O		TC1-CLK0	USART1-TXD	USART3-CLK	GLOC-OUT[1]	PWMA-PWMA[33]	SCIF-GCLK_IN[1]	EIC-EXTINT[4]	CAT-CSB[16]
44	56	PB11	43	VDDIO	Normal I/O		TC1-CLK1	USART1-RXD		ADCIFB-TRIGGER	PWMA-PWMA[34]	CAT-VDIVEN	EIC-EXTINT[5]	CAT-CSA[16]
5	7	PB12	44	VDDIO	Normal I/O		TC1-CLK2		TWIMS1-TWALM	CAT-SYNC	PWMA-PWMA[35]	ACIFB-ACBP[3]	SCIF-GCLK[4]	CAT-CSA[15]
15	22	PB13	45	VDDIN	USB I/O	USBC-DM	USART3-TXD			TC1-A1	PWMA-PWMA[7]	ADCIFB-ADP[1]	SCIF-GCLK[5]	CAT-CSB[2]
16	23	PB14	46	VDDIN	USB I/O	USBC-DP	USART3-RXD			TC1-B1	PWMA-PWMA[24]		SCIF-GCLK[5]	CAT-CSB[9]
	57	PB15	47	VDDIO	High-drive I/O	ABDACB-CLK	IISCMCK		SPI-SCK	TC0-CLK2	PWMA-PWMA[8]		SCIF-GCLK[3]	CAT-CSB[4]



Table 3-1. GPIO Controller Function Multiplexing

	58	PB16	48	VDDIO	Normal I/O	ABDACB-DAC[0]	IISC-ISCK	USART0-TXD		PWMA-PWMA[9]		SCIF-GCLK[2]	CAT-CSA[5]
	59	PB17	49	VDDIO	Normal I/O	ABDACB-DAC[1]	IISC-IWS	USART0-RXD		PWMA-PWMA[10]			CAT-CSB[5]
	60	PB18	50	VDDIO	Normal I/O	ABDACB-DACN[0]	IISC-ISDI	USART0-RTS		PWMA-PWMA[12]			CAT-CSA[0]
	4	PB19	51	VDDIO	Normal I/O	ABDACB-DACN[1]	IISC-ISDO	USART0-CTS		PWMA-PWMA[20]		EIC-EXTINT[1]	CAT-CSA[12]
	5	PB20	52	VDDIO	Normal I/O	TWIMS1-TWD	USART2-RXD	SPI-NPCS[1]	TC0-A0	PWMA-PWMA[21]	USART1-RTS	USART1-CLK	CAT-CSA[14]
	40	PB21	53	VDDIO	Normal I/O	TWIMS1-TWCK	USART2-TXD	SPI-NPCS[2]	TC0-B0	PWMA-PWMA[28]	USART1-CTS	USART1-CLK	CAT-CSB[14]
	41	PB22	54	VDDIO	Normal I/O	TWIMS1-TWALM		SPI-NPCS[3]	TC0-CLK0	PWMA-PWMA[27]	ADCIFB-TRIGGER	SCIF-GCLK[0]	CAT-CSA[8]
	54	PB23	55	VDDIO	Normal I/O	SPI-MISO	USART2-RTS	USART2-CLK	TC0-A2	PWMA-PWMA[0]	CAT-SMP	SCIF-GCLK[6]	CAT-CSA[4]
	55	PB24	56	VDDIO	Normal I/O	SPI-MOSI	USART2-CTS	USART2-CLK	TC0-B2	PWMA-PWMA[1]	ADCIFB-ADP[1]	SCIF-GCLK[7]	CAT-CSA[2]
	61	PB25	57	VDDIO	Normal I/O	SPI-NPCS[0]	USART1-RXD		TC0-A1	PWMA-PWMA[2]	SCIF-GCLK_IN[2]	SCIF-GCLK[8]	CAT-CSA[3]
	21	PB26	58	VDDIO	Normal I/O	SPI-SCK	USART1-TXD		TC0-B1	PWMA-PWMA[3]	ADCIFB-ADP[0]	SCIF-GCLK[9]	CAT-CSB[3]
	24	PB27	59	VDDIN	Normal I/O		USART1-RXD		TC0-CLK1	PWMA-PWMA[4]	ADCIFB-ADP[1]	EIC-EXTINT[0]	CAT-CSA[9]

See [Section 3.3](#) for a description of the various peripheral signals.

Refer to ["Electrical Characteristics" on page 34](#) for a description of the electrical properties of the pin types used.

3.2.2 TWI, 5V Tolerant, and SMBUS Pins

Some normal I/O pins offer TWI, 5V tolerance, and SMBUS features. These features are only available when either of the TWI functions or the PWMAOD function in the PWMA are selected for these pins.

Refer to the ["Electrical Characteristics" on page 34](#) for a description of the electrical properties of the TWI, 5V tolerance, and SMBUS pins.

3.2.3 Peripheral Functions

Each GPIO line can be assigned to one of several peripheral functions. The following table describes how the various peripheral functions are selected. The last listed function has priority in case multiple functions are enabled on the same pin.

Table 3-2. Peripheral Functions

Function	Description
GPIO Controller Function multiplexing	GPIO and GPIO peripheral selection A to H
Nexus OCD AUX port connections	OCD trace system
aWire DATAOUT	aWire output in two-pin mode
JTAG port connections	JTAG debug port
Oscillators	OSC0, OSC32

3.2.4 JTAG Port Connections

If the JTAG is enabled, the JTAG will take control over a number of pins, irrespectively of the I/O Controller configuration.

Table 3-3. JTAG Pinout

48-pin	64-pin	Pin name	JTAG pin
11	15	PA00	TCK
14	18	PA01	TMS
13	17	PA02	TDO
4	6	PA03	TDI

3.2.5 Nexus OCD AUX Port Connections

If the OCD trace system is enabled, the trace system will take control over a number of pins, irrespectively of the I/O Controller configuration. Two different OCD trace pin mappings are possible, depending on the configuration of the OCD AXS register. For details, see the AVR32 UC Technical Reference Manual.

Table 3-4. Nexus OCD AUX Port Connections

Pin	AXS=1	AXS=0
EVTI_N	PA05	PB08
MDO[5]	PA10	PB00
MDO[4]	PA18	PB04
MDO[3]	PA17	PB05
MDO[2]	PA16	PB03
MDO[1]	PA15	PB02
MDO[0]	PA14	PB09

Table 3-4. Nexus OCD AUX Port Connections

Pin	AXS=1	AXS=0
EVTO_N	PA04	PA04
MCKO	PA06	PB01
MSEO[1]	PA07	PB11
MSEO[0]	PA11	PB12

3.2.6 Oscillator Pinout

The oscillators are not mapped to the normal GPIO functions and their muxings are controlled by registers in the System Control Interface (SCIF). Please refer to the SCIF chapter for more information about this.

Table 3-5. Oscillator Pinout

48-pin	64-pin	Pin Name	Oscillator Pin
3	3	PA08	XIN0
46	62	PA10	XIN32
26	34	PA13	XIN32_2
2	2	PA09	XOUT0
47	63	PA12	XOUT32
25	33	PA20	XOUT32_2

3.2.7 Other Functions

The functions listed in [Table 3-6](#) are not mapped to the normal GPIO functions. The aWire DATA pin will only be active after the aWire is enabled. The aWire DATAOUT pin will only be active after the aWire is enabled and the 2_PIN_MODE command has been sent. The WAKE_N pin is always enabled. Please refer to [Section 5.1.4.2 on page 30](#) for constraints on the WAKE_N pin.

Table 3-6. Other Functions

48-pin	64-pin	Pin Name	Function
27	35	PA11	WAKE_N
22	30	RESET_N	aWire DATA
11	15	PA00	aWire DATAOUT

3.3 Signal Descriptions

The following table gives details on signal name classified by peripheral.

Table 3-7. Signal Descriptions List

Signal Name	Function	Type	Active Level	Comments
Audio Bitstream DAC - ABDACB				
CLK	D/A Clock out	Output		
DAC1 - DAC0	D/A Bitstream out	Output		
DACN1 - DACN0	D/A Inverted bitstream out	Output		
Analog Comparator Interface - ACIFB				
ACAN3 - ACAN0	Negative inputs for comparators "A"	Analog		
ACAP3 - ACAP0	Positive inputs for comparators "A"	Analog		
ACBN3 - ACBN0	Negative inputs for comparators "B"	Analog		
ACBP3 - ACBP0	Positive inputs for comparators "B"	Analog		
ACREFN	Common negative reference	Analog		
ADC Interface - ADCIFB				
AD8 - AD0	Analog Signal	Analog		
ADP1 - ADP0	Drive Pin for resistive touch screen	Output		
TRIGGER	External trigger	Input		
aWire - AW				
DATA	aWire data	I/O		
DATAOUT	aWire data output for 2-pin mode	I/O		
Capacitive Touch Module - CAT				
CSA16 - CSA0	Capacitive Sense A	I/O		
CSB16 - CSB0	Capacitive Sense B	I/O		
DIS	Discharge current control	Analog		
SMP	SMP signal	Output		
SYNC	Synchronize signal	Input		
VDIVEN	Voltage divider enable	Output		
External Interrupt Controller - EIC				
EXTINT5 - EXTINT0	External interrupt	Input		
Glue Logic Controller - GLOC				
IN7 - IN0	Inputs to lookup tables	Input		
OUT1 - OUT0	Outputs from lookup tables	Output		
Inter-IC Sound (I2S) Controller - IISC				
IMCK	I2S Master Clock	Output		

Table 3-7. Signal Descriptions List

ISCK	I2S Serial Clock	I/O		
ISDI	I2S Serial Data In	Input		
ISDO	I2S Serial Data Out	Output		
IWS	I2S Word Select	I/O		
JTAG module - JTAG				
TCK	Test Clock	Input		
TDI	Test Data In	Input		
TDO	Test Data Out	Output		
TMS	Test Mode Select	Input		
Power Manager - PM				
RESET_N	Reset	Input	Low	
Pulse Width Modulation Controller - PWMA				
PWMA35 - PWMA0	PWMA channel waveforms	Output		
PWMAOD35 - PWMAOD0	PWMA channel waveforms, open drain mode	Output		Not all channels support open drain mode
System Control Interface - SCIF				
GCLK9 - GCLK0	Generic Clock Output	Output		
GCLK_IN2 - GCLK_IN0	Generic Clock Input	Input		
RC32OUT	RC32K output at startup	Output		
XIN0	Crystal 0 Input	Analog/ Digital		
XIN32	Crystal 32 Input (primary location)	Analog/ Digital		
XIN32_2	Crystal 32 Input (secondary location)	Analog/ Digital		
XOUT0	Crystal 0 Output	Analog		
XOUT32	Crystal 32 Output (primary location)	Analog		
XOUT32_2	Crystal 32 Output (secondary location)	Analog		
Serial Peripheral Interface - SPI				
MISO	Master In Slave Out	I/O		
MOSI	Master Out Slave In	I/O		
NPCS3 - NPCS0	SPI Peripheral Chip Select	I/O	Low	
SCK	Clock	I/O		
Timer/Counter - TC0, TC1				
A0	Channel 0 Line A	I/O		
A1	Channel 1 Line A	I/O		
A2	Channel 2 Line A	I/O		
B0	Channel 0 Line B	I/O		

Table 3-7. Signal Descriptions List

B1	Channel 1 Line B	I/O		
B2	Channel 2 Line B	I/O		
CLK0	Channel 0 External Clock Input	Input		
CLK1	Channel 1 External Clock Input	Input		
CLK2	Channel 2 External Clock Input	Input		
Two-wire Interface - TWIM0, TWIM1				
TWALM	SMBus SMBALERT	I/O	Low	
TWCK	Two-wire Serial Clock	I/O		
TWD	Two-wire Serial Data	I/O		
Universal Synchronous Asynchronous Receiver Transmitter - USART0, USART1, USART2, USART3				
CLK	Clock	I/O		
CTS	Clear To Send	Input	Low	
RTS	Request To Send	Output	Low	
RXD	Receive Data	Input		
TXD	Transmit Data	Output		

Note: 1. ADCIFB: AD3 does not exist.

Table 3-8. Signal Description List, Continued

Signal Name	Function	Type	Active Level	Comments
Power				
VDDCORE	Core Power Supply / Voltage Regulator Output	Power Input/Output		1.62V to 1.98V
VDDIO	I/O Power Supply	Power Input		1.62V to 3.6V. VDDIO should always be equal to or lower than VDDIN.
VDDANA	Analog Power Supply	Power Input		1.62V to 1.98V
ADVREFP	Analog Reference Voltage	Power Input		1.62V to 1.98V
VDDIN	Voltage Regulator Input	Power Input		1.62V to 3.6V ⁽¹⁾
GNDANA	Analog Ground	Ground		
GND	Ground	Ground		
Auxiliary Port - AUX				
MCKO	Trace Data Output Clock	Output		
MDO5 - MDO0	Trace Data Output	Output		
MSEO1 - MSEO0	Trace Frame Control	Output		

Table 3-8. Signal Description List, Continued

Signal Name	Function	Type	Active Level	Comments
EVTI_N	Event In	Input	Low	
EVTO_N	Event Out	Output	Low	
General Purpose I/O pin				
PA22 - PA00	Parallel I/O Controller I/O Port 0	I/O		
PB27 - PB00	Parallel I/O Controller I/O Port 1	I/O		

Note: 1. See [Section 5. on page 25](#)

3.4 I/O Line Considerations

3.4.1 JTAG Pins

The JTAG is enabled if TCK is low while the RESET_N pin is released. The TCK, TMS, and TDI pins have pull-up resistors when JTAG is enabled. The TCK pin always has pull-up enabled during reset. The TDO pin is an output, driven at VDDIO, and has no pull-up resistor. The JTAG pins can be used as GPIO pins and multiplexed with peripherals when the JTAG is disabled. Please refer to [Section 3.2.4 on page 13](#) for the JTAG port connections.

3.4.2 PA00

Note that PA00 is multiplexed with TCK. PA00 GPIO function must only be used as output in the application.

3.4.3 RESET_N Pin

The RESET_N pin is a schmitt input and integrates a permanent pull-up resistor to VDDIN. As the product integrates a power-on reset detector, the RESET_N pin can be left unconnected in case no reset from the system needs to be applied to the product.

The RESET_N pin is also used for the aWire debug protocol. When the pin is used for debugging, it must not be driven by external circuitry.

3.4.4 TWI Pins PA21/PB04/PB05

When these pins are used for TWI, the pins are open-drain outputs with slew-rate limitation and inputs with spike filtering. When used as GPIO pins or used for other peripherals, the pins have the same characteristics as other GPIO pins. Selected pins are also SMBus compliant (refer to [Section on page 10](#)). As required by the SMBus specification, these pins provide no leakage path to ground when the ATUC64/128/256L3/4U is powered down. This allows other devices on the SMBus to continue communicating even though the ATUC64/128/256L3/4U is not powered.

After reset a TWI function is selected on these pins instead of the GPIO. Please refer to the GPIO Module Configuration chapter for details.

3.4.5 TWI Pins PA05/PA07/PA17

When these pins are used for TWI, the pins are open-drain outputs with slew-rate limitation and inputs with spike filtering. When used as GPIO pins or used for other peripherals, the pins have the same characteristics as other GPIO pins.

After reset a TWI function is selected on these pins instead of the GPIO. Please refer to the GPIO Module Configuration chapter for details.

3.4.6 GPIO Pins

All the I/O lines integrate a pull-up resistor. Programming of this pull-up resistor is performed independently for each I/O line through the GPIO Controllers. After reset, I/O lines default as inputs with pull-up resistors disabled, except PA00 which has the pull-up resistor enabled. PA20 selects SCIF-RC32OUT (GPIO Function F) as default enabled after reset.

3.4.7 High-drive Pins

The six pins PA02, PA06, PA08, PA09, PB01, and PB15 have high-drive output capabilities. Refer to [Section 7. on page 34](#) for electrical characteristics.

3.4.8 USB Pins PB13/PB14

When these pins are used for USB, the pins are behaving according to the USB specification. When used as GPIO pins or used for other peripherals, the pins have the same behaviour as other normal I/O pins, but the characteristics are different. Refer to [Section 7. on page 34](#) for electrical characteristics.

To be able to use the USB I/O the VDDIN power supply must be 3.3V nominal.

3.4.9 RC32OUT Pin**3.4.9.1 Clock output at startup**

After power-up, the clock generated by the 32kHz RC oscillator (RC32K) will be output on PA20, even when the device is still reset by the Power-On Reset Circuitry. This clock can be used by the system to start other devices or to clock a switching regulator to rise the power supply voltage up to an acceptable value.

The clock will be available on PA20, but will be disabled if one of the following conditions are true:

- PA20 is configured to use a GPIO function other than F (SCIF-RC32OUT)
- PA20 is configured as a General Purpose Input/Output (GPIO)
- The bit FRC32 in the Power Manager PPCR register is written to zero (refer to the Power Manager chapter)

The maximum amplitude of the clock signal will be defined by VDDIN.

Once the RC32K output on PA20 is disabled it can never be enabled again.

3.4.9.2 XOUT32_2 function

PA20 selects RC32OUT as default enabled after reset. This function is not automatically disabled when the user enables the XOUT32_2 function on PA20. This disturbs the oscillator and may result in the wrong frequency. To avoid this, RC32OUT must be disabled when XOUT32_2 is enabled.

3.4.10 ADC Input Pins

These pins are regular I/O pins powered from the VDDIO. However, when these pins are used for ADC inputs, the voltage applied to the pin must not exceed 1.98V. Internal circuitry ensures that the pin cannot be used as an analog input pin when the I/O drives to VDD. When the pins are not used for ADC inputs, the pins may be driven to the full I/O voltage range.

4. Memories

4.1 Embedded Memories

- Internal high-speed flash
 - 256Kbytes (ATUC256L3U, ATUC256L4U)
 - 128Kbytes (ATUC128L3U, ATUC128L4U)
 - 64Kbytes (ATUC64L3U, ATUC64L4U)
 - 0 wait state access at up to 25MHz in worst case conditions
 - 1 wait state access at up to 50MHz in worst case conditions
 - Pipelined flash architecture, allowing burst reads from sequential flash locations, hiding penalty of 1 wait state access
 - Pipelined flash architecture typically reduces the cycle penalty of 1 wait state operation to only 8% compared to 0 wait state operation
 - 100 000 write cycles, 15-year data retention capability
 - Sector lock capabilities, bootloader protection, security bit
 - 32 fuses, erased during chip erase
 - User page for data to be preserved during chip erase
- Internal high-speed SRAM, single-cycle access at full speed
 - 32Kbytes (ATUC256L3U, ATUC256L4U, ATUC128L3U, ATUC128L4U)
 - 16Kbytes (ATUC64L3U, ATUC64L4U)

4.2 Physical Memory Map

The system bus is implemented as a bus matrix. All system bus addresses are fixed, and they are never remapped in any way, not even during boot. Note that AVR32 UC CPU uses unsegmented translation, as described in the AVR32 Architecture Manual. The 32-bit physical address space is mapped as follows:

Table 4-1. ATUC64/128/256L3/4U Physical Memory Map

Memory	Start Address	Size		
		ATUC256L3U, ATUC256L4U	ATUC128L3U, ATUC128L4U	ATUC64L3U, ATUC64L4U
Embedded SRAM	0x00000000	32Kbytes	32Kbytes	16Kbytes
Embedded Flash	0x80000000	256Kbytes	128Kbytes	64Kbytes
SAU Channels	0x90000000	256 bytes	256 bytes	256 bytes
HSB-PB Bridge B	0xFFFFE000	64Kbytes	64Kbytes	64Kbytes
HSB-PB Bridge A	0xFFFF0000	64Kbytes	64Kbytes	64Kbytes

Table 4-2. Flash Memory Parameters

Device	Flash Size (<i>FLASH_PW</i>)	Number of Pages (<i>FLASH_P</i>)	Page Size (<i>FLASH_W</i>)
ATUC256L3U, ATUC256L4U	256Kbytes	512	512 bytes
ATUC128L3U, ATUC128L4U	128Kbytes	256	512 bytes
ATUC64L3U, ATUC64L4U	64Kbytes	128	512 bytes

4.3 Peripheral Address Map

Table 4-3. Peripheral Address Mapping

Address		Peripheral Name
0xFFFE0000	FLASHCDW	Flash Controller - FLASHCDW
0xFFFE0400	HMATRIX	HSB Matrix - HMATRIX
0xFFFE0800	SAU	Secure Access Unit - SAU
0xFFFE1000	USBC	USB 2.0 Interface - USBC
0xFFFF0000	PDCA	Peripheral DMA Controller - PDCA
0xFFFF1000	INTC	Interrupt controller - INTC
0xFFFF1400	PM	Power Manager - PM
0xFFFF1800	SCIF	System Control Interface - SCIF
0xFFFF1C00	AST	Asynchronous Timer - AST
0xFFFF2000	WDT	Watchdog Timer - WDT
0xFFFF2400	EIC	External Interrupt Controller - EIC
0xFFFF2800	FREQM	Frequency Meter - FREQM
0xFFFF2C00	GPIO	General-Purpose Input/Output Controller - GPIO
0xFFFF3000	USART0	Universal Synchronous Asynchronous Receiver Transmitter - USART0
0xFFFF3400	USART1	Universal Synchronous Asynchronous Receiver Transmitter - USART1
0xFFFF3800	USART2	Universal Synchronous Asynchronous Receiver Transmitter - USART2
0xFFFF3C00	USART3	Universal Synchronous Asynchronous Receiver Transmitter - USART3
0xFFFF4000	SPI	Serial Peripheral Interface - SPI

Table 4-3. Peripheral Address Mapping

0xFFFF4400	TWIM0	Two-wire Master Interface - TWIM0
0xFFFF4800	TWIM1	Two-wire Master Interface - TWIM1
0xFFFF4C00	TWIS0	Two-wire Slave Interface - TWIS0
0xFFFF5000	TWIS1	Two-wire Slave Interface - TWIS1
0xFFFF5400	PWMA	Pulse Width Modulation Controller - PWMA
0xFFFF5800	TC0	Timer/Counter - TC0
0xFFFF5C00	TC1	Timer/Counter - TC1
0xFFFF6000	ADCIFB	ADC Interface - ADCIFB
0xFFFF6400	ACIFB	Analog Comparator Interface - ACIFB
0xFFFF6800	CAT	Capacitive Touch Module - CAT
0xFFFF6C00	GLOC	Glue Logic Controller - GLOC
0xFFFF7000	AW	aWire - AW
0xFFFF7400	ABDACB	Audio Bitstream DAC - ABDACB
0xFFFF7800	IISC	Inter-IC Sound (I2S) Controller - IISC

4.4 CPU Local Bus Mapping

Some of the registers in the GPIO module are mapped onto the CPU local bus, in addition to being mapped on the Peripheral Bus. These registers can therefore be reached both by accesses on the Peripheral Bus, and by accesses on the local bus.

Mapping these registers on the local bus allows cycle-deterministic toggling of GPIO pins since the CPU and GPIO are the only modules connected to this bus. Also, since the local bus runs at CPU speed, one write or read operation can be performed per clock cycle to the local bus-mapped GPIO registers.

The following GPIO registers are mapped on the local bus:

Table 4-4. Local Bus Mapped GPIO Registers

Port	Register	Mode	Local Bus Address	Access
0	Output Driver Enable Register (ODER)	WRITE	0x40000040	Write-only
		SET	0x40000044	Write-only
		CLEAR	0x40000048	Write-only
		TOGGLE	0x4000004C	Write-only
	Output Value Register (OVR)	WRITE	0x40000050	Write-only
		SET	0x40000054	Write-only
		CLEAR	0x40000058	Write-only
		TOGGLE	0x4000005C	Write-only
Pin Value Register (PVR)	-	0x40000060	Read-only	
1	Output Driver Enable Register (ODER)	WRITE	0x40000140	Write-only
		SET	0x40000144	Write-only
		CLEAR	0x40000148	Write-only
		TOGGLE	0x4000014C	Write-only
	Output Value Register (OVR)	WRITE	0x40000150	Write-only
		SET	0x40000154	Write-only
		CLEAR	0x40000158	Write-only
		TOGGLE	0x4000015C	Write-only
	Pin Value Register (PVR)	-	0x40000160	Read-only

5. Supply and Startup Considerations

5.1 Supply Considerations

5.1.1 Power Supplies

The ATUC64/128/256L3/4U has several types of power supply pins:

- VDDIO: Powers I/O lines. Voltage is 1.8 to 3.3V nominal.
- VDDIN: Powers I/O lines, the USB pins, and the internal regulator. Voltage is 1.8 to 3.3V nominal if USB is not used, and 3.3V nominal when USB is used.
- VDDANA: Powers the ADC. Voltage is 1.8V nominal.
- VDDCORE: Powers the core, memories, and peripherals. Voltage is 1.8V nominal.

The ground pins GND are common to VDDCORE, VDDIO, and VDDIN. The ground pin for VDDANA is GNDANA.

When VDDCORE is not connected to VDDIN, the VDDIN voltage must be higher than 1.98V.

Refer to [Section 7. on page 34](#) for power consumption on the various supply pins.

For decoupling recommendations for the different power supplies, please refer to the schematic checklist.

Refer to [Section on page 10](#) for power supply connections for I/O pins.

5.1.2 Voltage Regulator

The ATUC64/128/256L3/4U embeds a voltage regulator that converts from 3.3V nominal to 1.8V with a load of up to 60 mA. The regulator supplies the output voltage on VDDCORE. The regulator may only be used to drive internal circuitry in the device. VDDCORE should be externally connected to the 1.8V domains. See [Section 5.1.3](#) for regulator connection figures.

Adequate output supply decoupling is mandatory for VDDCORE to reduce ripple and avoid oscillations. The best way to achieve this is to use two capacitors in parallel between VDDCORE and GND as close to the device as possible. Please refer to [Section 7.8 on page 47](#) for decoupling capacitors values and regulator characteristics.

Figure 5-1. Supply Decoupling.

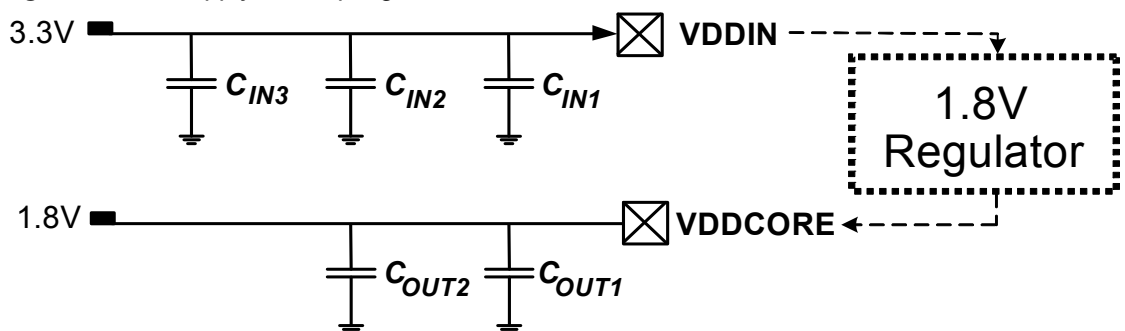

The voltage regulator can be turned off in the shutdown mode to power down the core logic and keep a small part of the system powered in order to reduce power consumption. To enter this mode the 3.3V supply mode, with 1.8V regulated I/O lines power supply configuration must be used.

5.1.3 Regulator Connection

The ATUC64/128/256L3/4U supports three power supply configurations:

- 3.3V single supply mode
 - Shutdown mode is not available
- 1.8V single supply mode
 - Shutdown mode is not available
- 3.3V supply mode, with 1.8V regulated I/O lines
 - Shutdown mode is available

5.1.3.1 3.3V Single Supply Mode

In 3.3V single supply mode the internal regulator is connected to the 3.3V source (VDDIN pin) and its output feeds VDDCORE. Figure 5-2 shows the power schematics to be used for 3.3V single supply mode. All I/O lines will be powered by the same power (VDDIN=VDDIO).

Figure 5-2. 3.3V Single Supply Mode

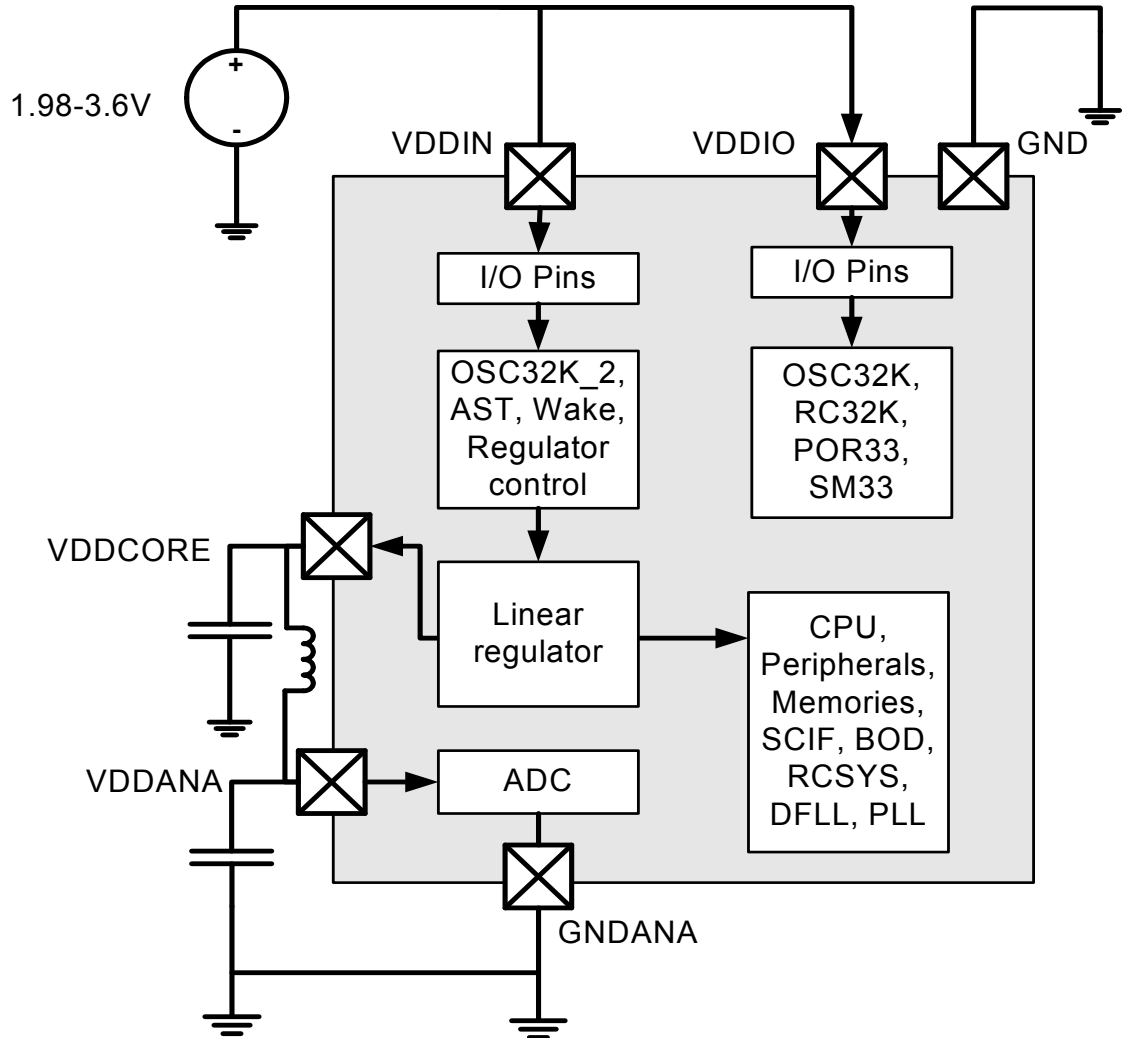

5.1.3.2 1.8V Single Supply Mode

In 1.8V single supply mode the internal regulator is not used, and VDDIO and VDDCORE are powered by a single 1.8V supply as shown in Figure 5-3. All I/O lines will be powered by the same power (VDDIN = VDDIO = VDDCORE).

Figure 5-3. 1.8V Single Supply Mode

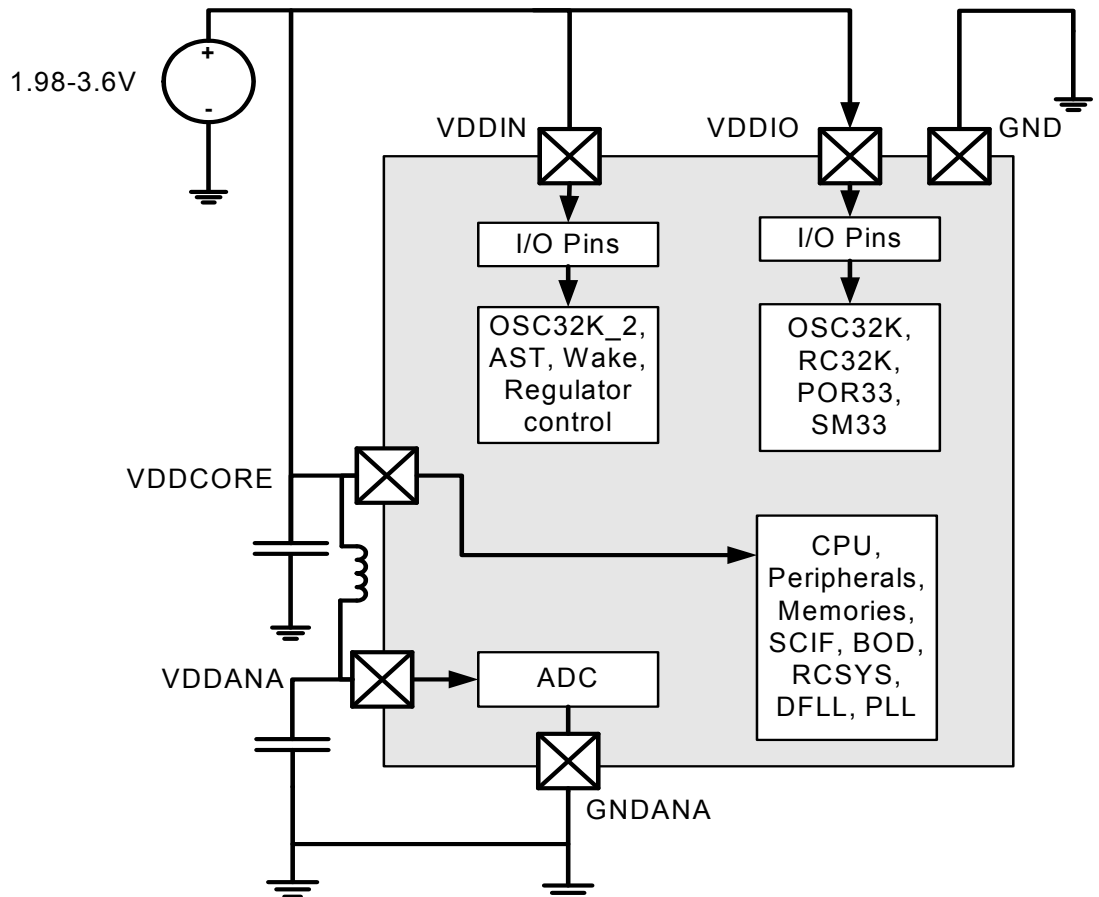

5.1.3.3 3.3V Supply Mode with 1.8V Regulated I/O Lines

In this mode, the internal regulator is connected to the 3.3V source and its output is connected to both VDDCORE and VDDIO as shown in Figure 5-4. This configuration is required in order to use Shutdown mode.

Figure 5-4. 3.3V Supply Mode with 1.8V Regulated I/O Lines

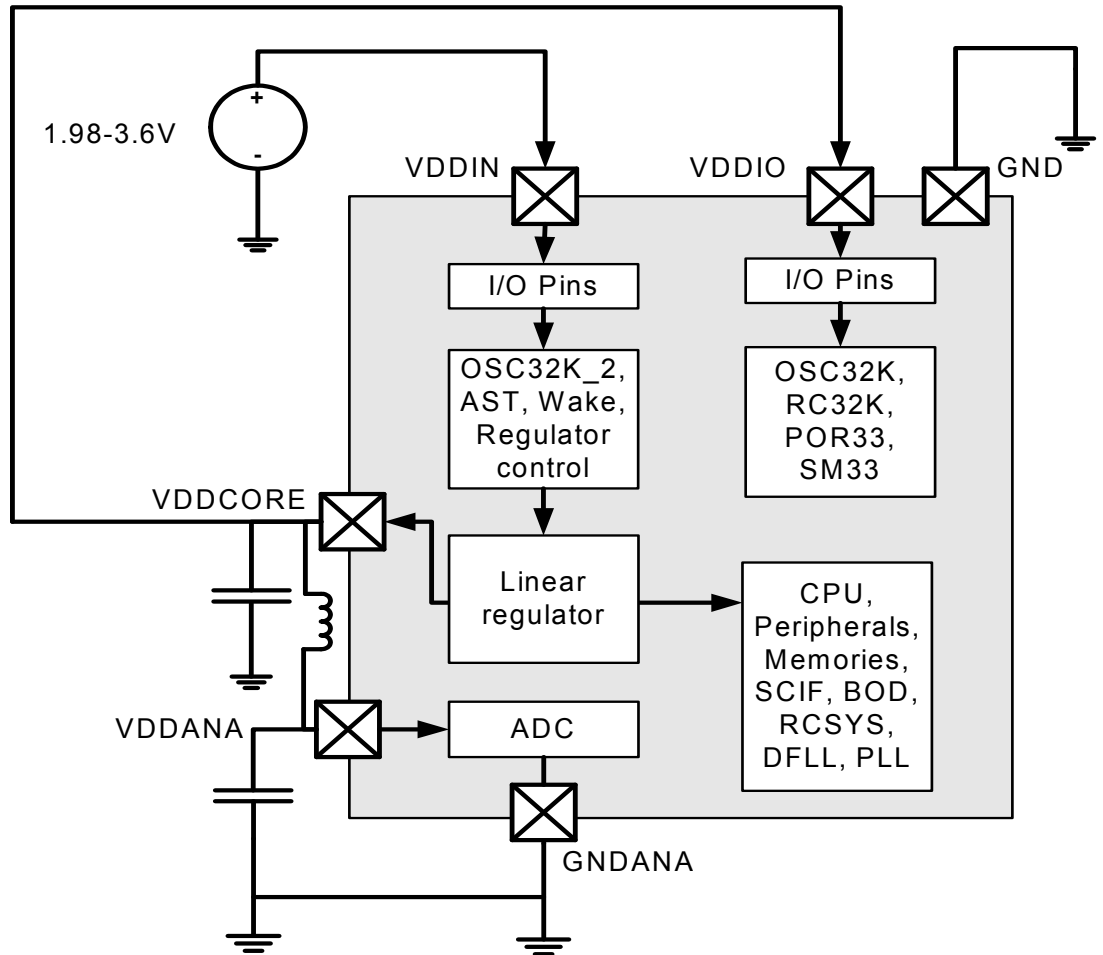

In this mode, some I/O lines are powered by VDDIN while other I/O lines are powered by VDDIO. Refer to [Section on page 10](#) for description of power supply for each I/O line.

Refer to the Power Manager chapter for a description of what parts of the system are powered in Shutdown mode.

Important note: As the regulator has a maximum output current of 60 mA, this mode can only be used in applications where the maximum I/O current is known and compatible with the core and peripheral power consumption. Typically, great care must be used to ensure that only a few I/O lines are toggling at the same time and drive very small loads.

5.1.4 Power-up Sequence

5.1.4.1 Maximum Rise Rate

To avoid risk of latch-up, the rise rate of the power supplies must not exceed the values described in [Table 7-3 on page 35](#).

Recommended order for power supplies is also described in this chapter.

5.1.4.2 Minimum Rise Rate

The integrated Power-on Reset (POR33) circuitry monitoring the VDDIN powering supply requires a minimum rise rate for the VDDIN power supply.

See [Table 7-3 on page 35](#) for the minimum rise rate value.

If the application can not ensure that the minimum rise rate condition for the VDDIN power supply is met, one of the following configurations can be used:

- A logic “0” value is applied during power-up on pin PA11 (WAKE_N) until VDDIN rises above 1.2V.
- A logic “0” value is applied during power-up on pin RESET_N until VDDIN rises above 1.2V.

5.2 Startup Considerations

This chapter summarizes the boot sequence of the ATUC64/128/256L3/4U. The behavior after power-up is controlled by the Power Manager. For specific details, refer to the Power Manager chapter.

5.2.1 Starting of Clocks

After power-up, the device will be held in a reset state by the Power-on Reset (POR18 and POR33) circuitry for a short time to allow the power to stabilize throughout the device. After reset, the device will use the System RC Oscillator (RCSYS) as clock source. Please refer to [Table 7-17 on page 46](#) for the frequency for this oscillator.

On system start-up, the DFLL is disabled. All clocks to all modules are running. No clocks have a divided frequency; all parts of the system receive a clock with the same frequency as the System RC Oscillator.

When powering up the device, there may be a delay before the voltage has stabilized, depending on the rise time of the supply used. The CPU can start executing code as soon as the supply is above the POR18 and POR33 thresholds, and before the supply is stable. Before switching to a high-speed clock source, the user should use the BOD to make sure the VDDCORE is above the minimum level (1.62V).

5.2.2 Fetching of Initial Instructions

After reset has been released, the AVR32 UC CPU starts fetching instructions from the reset address, which is 0x80000000. This address points to the first address in the internal Flash.

The code read from the internal flash is free to configure the clock system and clock sources. Please refer to the PM and SCIF chapters for more details.

6. Programming and Debugging

6.1 Overview

The ATUC64/128/256L3/4U supports programming and debugging through two interfaces, JTAG or aWire. JTAG is an industry standard interface and allows boundary scan for PCB testing, as well as daisy-chaining of multiple devices on the PCB. aWire is an Atmel proprietary protocol which offers higher throughput and robust communication, and does not require application pins to be reserved. Either interface provides access to the internal Service Access Bus (SAB), which offers a bridge to the High Speed Bus, giving access to memories and peripherals in the device. By using this bridge to the bus system, the flash and fuses can thus be programmed by accessing the Flash Controller in the same manner as the CPU.

The SAB also provides access to the Nexus-compliant On-chip Debug (OCD) system in the device, which gives the user non-intrusive run-time control of the program execution. Additionally, trace information can be output on the Auxiliary (AUX) debug port or buffered in internal RAM for later retrieval by JTAG or aWire.

6.2 Service Access Bus

The AVR32 architecture offers a common interface for access to On-chip Debug, programming, and test functions. These are mapped on a common bus called the Service Access Bus (SAB), which is linked to the JTAG and aWire port through a bus master module, which also handles synchronization between the debugger and SAB clocks.

When accessing the SAB through the debugger there are no limitations on debugger frequency compared to chip frequency, although there must be an active system clock in order for the SAB accesses to complete. If the system clock is switched off in sleep mode, activity on the debugger will restart the system clock automatically, without waking the device from sleep. Debuggers may optimize the transfer rate by adjusting the frequency in relation to the system clock. This ratio can be measured with debug protocol specific instructions.

The Service Access Bus uses 36 address bits to address memory or registers in any of the slaves on the bus. The bus supports sized accesses of bytes (8 bits), halfwords (16 bits), or words (32 bits). All accesses must be aligned to the size of the access, i.e. halfword accesses must have the lowest address bit cleared, and word accesses must have the two lowest address bits cleared.

6.2.1 SAB Address Map

The SAB gives the user access to the internal address space and other features through a 36 bits address space. The 4 MSBs identify the slave number, while the 32 LSBs are decoded within the slave's address space. The SAB slaves are shown in [Table 6-1](#).

Table 6-1. SAB Slaves, Addresses and Descriptions

Slave	Address [35:32]	Description
Unallocated	0x0	Intentionally unallocated
OCD	0x1	OCD registers
HSB	0x4	HSB memory space, as seen by the CPU

Table 6-1. SAB Slaves, Addresses and Descriptions

Slave	Address [35:32]	Description
HSB	0x5	Alternative mapping for HSB space, for compatibility with other 32-bit AVR devices.
Memory Service Unit	0x6	Memory Service Unit registers
Reserved	Other	Unused

6.2.2 SAB Security Restrictions

The Service Access bus can be restricted by internal security measures. A short description of the security measures are found in the table below.

6.2.2.1 Security measure and control location

A security measure is a mechanism to either block or allow SAB access to a certain address or address range. A security measure is enabled or disabled by one or several control signals. This is called the control location for the security measure.

These security measures can be used to prevent an end user from reading out the code programmed in the flash, for instance.

Table 6-2. SAB Security Measures

Security Measure	Control Location	Description
Secure mode	FLASHCDW SECURE bits set	Allocates a portion of the flash for secure code. This code cannot be read or debugged. The User page is also locked.
Security bit	FLASHCDW security bit set	Programming and debugging not possible, very restricted access.
User code programming	FLASHCDW UPROT + security bit set	Restricts all access except parts of the flash and the flash controller for programming user code. Debugging is not possible unless an OS running from the secure part of the flash supports it.

Below follows a more in depth description of what locations are accessible when the security measures are active.

Table 6-3. Secure Mode SAB Restrictions

Name	Address Start	Address End	Access
Secure flash area	0x580000000	0x580000000 + (USERPAGE[15:0] << 10)	Blocked
Secure RAM area	0x500000000	0x500000000 + (USERPAGE[31:16] << 10)	Blocked
User page	0x580800000	0x581000000	Read
Other accesses	-	-	As normal

Note: 1. Second Word of the User Page, refer to the Fuses Settings section for details.

Table 6-4. Security Bit SAB Restrictions

Name	Address start	Address end	Access
OCD DCCPU, OCD DCEMU, OCD DCSR	0x100000110	0x100000118	Read/Write
User page	0x580800000	0x581000000	Read
Other accesses	-	-	Blocked

Table 6-5. User Code Programming SAB Restrictions

Name	Address start	Address end	Access
OCD DCCPU, OCD DCEMU, OCD DCSR	0x100000110	0x100000118	Read/Write
User page	0x580800000	0x581000000	Read
FLASHCDW PB interface	0x5FFFE0000	0x5FFFE0400	Read/Write
FLASH pages outside BOOTPROT	0x580000000 + BOOTPROT size	0x580000000 + Flash size	Read/Write
Other accesses	-	-	Blocked

7. Electrical Characteristics

7.1 Absolute Maximum Ratings*

Table 7-1. Absolute Maximum Ratings

Operating temperature.....	-40°C to +85°C
Storage temperature.....	-60°C to +150°C
Voltage on input pins (except for 5V pins) with respect to ground	-0.3V to $V_{VDD}^{(2)}$ +0.3V
Voltage on 5V tolerant ⁽¹⁾ pins with respect to ground	-0.3V to 5.5V
Total DC output current on all I/O pins - VDDIO, 64-pin package	141 mA
Total DC output current on all I/O pins - VDDIN, 64-pin package	42 mA
Total DC output current on all I/O pins - VDDIO, 48-pin package	120mA
Total DC output current on all I/O pins - VDDIN, 48-pin package	39 mA
Maximum operating voltage VDDCORE.....	1.98V
Maximum operating voltage VDDIO, VDDIN	3.6V

*NOTICE: Stresses beyond those listed under “Absolute Maximum Ratings” may cause permanent damage to the device. This is a stress rating only and functional operation of the device at these or other conditions beyond those indicated in the operational sections of this specification is not implied. Exposure to absolute maximum rating conditions for extended periods may affect device reliability.

- Notes: 1. 5V tolerant pins, see [Section ”” on page 10](#)
 2. V_{VDD} corresponds to either V_{VDDIN} or V_{VDDIO} , depending on the supply for the pin. Refer to [Section on page 10](#) for details.

7.2 Supply Characteristics

The following characteristics are applicable to the operating temperature range: $T_A = -40^\circ\text{C}$ to 85°C , unless otherwise specified and are valid for a junction temperature up to $T_J = 100^\circ\text{C}$. Please refer to [Section 5. ”Supply and Startup Considerations” on page 25](#).

Table 7-2. Supply Characteristics

Symbol	Parameter	Voltage		
		Min	Max	Unit
V_{VDDIO}	DC supply peripheral I/Os	1.62	3.6	V
V_{VDDIN}	DC supply peripheral I/Os, 1.8V single supply mode	1.62	1.98	V
	DC supply peripheral I/Os and internal regulator, 3.3V supply mode	1.98	3.6	V
$V_{VDDCORE}$	DC supply core	1.62	1.98	V
V_{VDDANA}	Analog supply voltage	1.62	1.98	V

Table 7-3. Supply Rise Rates and Order⁽¹⁾

Symbol	Parameter	Rise Rate			
		Min	Max	Unit	Comment
V _{VDDIO}	DC supply peripheral I/Os	0	2.5	V/μs	
V _{VDDIN}	DC supply peripheral I/Os and internal regulator	0.002	2.5	V/μs	Slower rise time requires external power-on reset circuit.
V _{VDDCORE}	DC supply core	0	2.5	V/μs	Rise before or at the same time as VDDIO
V _{VDDANA}	Analog supply voltage	0	2.5	V/μs	Rise together with VDDCORE

Note: 1. These values are based on simulation and characterization of other AVR microcontrollers manufactured in the same process technology. These values are not covered by test limits in production.

7.3 Maximum Clock Frequencies

These parameters are given in the following conditions:

- V_{VDDCORE} = 1.62V to 1.98V
- Temperature = -40°C to 85°C

Table 7-4. Clock Frequencies

Symbol	Parameter	Description	Min	Max	Units
f _{CPU}	CPU clock frequency			50	MHz
f _{PBA}	PBA clock frequency			50	
f _{PBB}	PBB clock frequency			50	
f _{GCLK0}	GCLK0 clock frequency	DPLLIF main reference, GCLK0 pin		50	
f _{GCLK1}	GCLK1 clock frequency	DPLLIF dithering and SSGreference, GCLK1 pin		50	
f _{GCLK2}	GCLK2 clock frequency	AST, GCLK2 pin		20	
f _{GCLK3}	GCLK3 clock frequency	PWMA, GCLK3 pin		140	
f _{GCLK4}	GCLK4 clock frequency	CAT, ACIFB, GCLK4 pin		50	
f _{GCLK5}	GCLK5 clock frequency	GLOC and GCLK5 pin		80	
f _{GCLK6}	GCLK6 clock frequency	ABDACB, IISC, and GCLK6 pin		50	
f _{GCLK7}	GCLK7 clock frequency	USBC and GCLK7 pin		50	
f _{GCLK8}	GCLK8 clock frequency	PLL0 source clock and GCLK8 pin		50	
f _{GCLK9}	GCLK9 clock frequency	FREQM, GCLK0-8, GCLK9 pin		150	

7.4 Power Consumption

The values in [Table 7-5](#) are measured values of power consumption under the following conditions, except where noted:

- Operating conditions, internal core supply ([Figure 7-1](#)) - this is the default configuration
 - V_{VDDIN} = 3.0V

- $V_{VDDCORE} = 1.62V$, supplied by the internal regulator
- Corresponds to the 3.3V supply mode with 1.8V regulated I/O lines, please refer to the Supply and Startup Considerations section for more details
 - Equivalent to the 3.3V single supply mode
 - Consumption in 1.8V single supply mode can be estimated by subtracting the regulator static current
- Operating conditions, external core supply (Figure 7-2) - used only when noted
 - $V_{VDDIN} = V_{VDDCORE} = 1.8V$
 - Corresponds to the 1.8V single supply mode, please refer to the Supply and Startup Considerations section for more details
- $T_A = 25^{\circ}C$
- Oscillators
 - OSC0 (crystal oscillator) stopped
 - OSC32K (32KHz crystal oscillator) running with external 32KHz crystal
 - DFLL running at 50MHz with OSC32K as reference
- Clocks
 - DFLL used as main clock source
 - CPU, HSB, and PBB clocks undivided
 - PBA clock divided by 4
 - The following peripheral clocks running
 - PM, SCIF, AST, FLASHCDW, PBA bridge
 - All other peripheral clocks stopped
- I/Os are inactive with internal pull-up
- Flash enabled in high speed mode
- POR18 enabled
- POR33 disabled

Table 7-5. Power Consumption for Different Operating Modes

Mode	Conditions	Measured on	Consumption Typ	Unit
Active ⁽¹⁾	CPU running a recursive Fibonacci algorithm	Amp0	300	$\mu\text{A}/\text{MHz}$
	CPU running a division algorithm		174	
Idle ⁽¹⁾	96			
Frozen ⁽¹⁾	57			
Standby ⁽¹⁾	46			
Stop	38		μA	
DeepStop	25			
Static	-OSC32K and AST stopped -Internal core supply			14
	-OSC32K running -AST running at 1 KHz -External core supply (Figure 7-2)			7.3
	-OSC32K and AST stopped -External core supply (Figure 7-2)			6.7
Shutdown	-OSC32K running -AST running at 1 KHz	800	nA	
	AST and OSC32K stopped	220		

Note: 1. These numbers are valid for the measured condition only and must not be extrapolated to other frequencies.

Figure 7-1. Measurement Schematic, Internal Core Supply

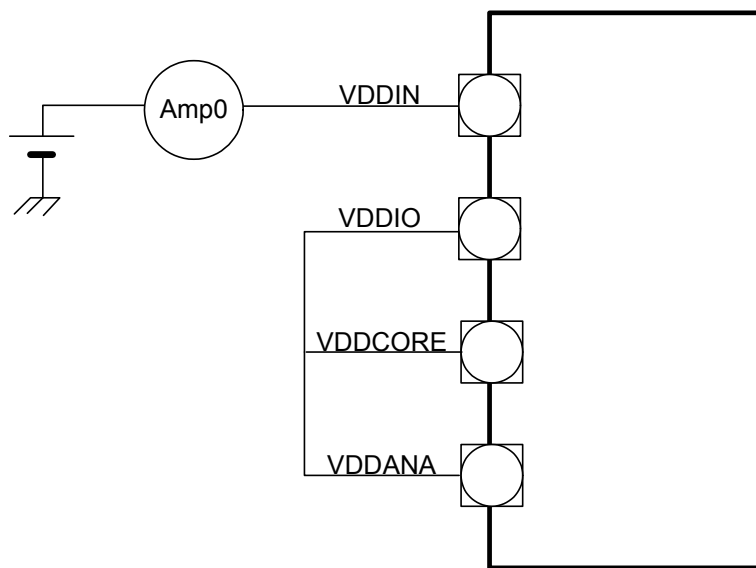
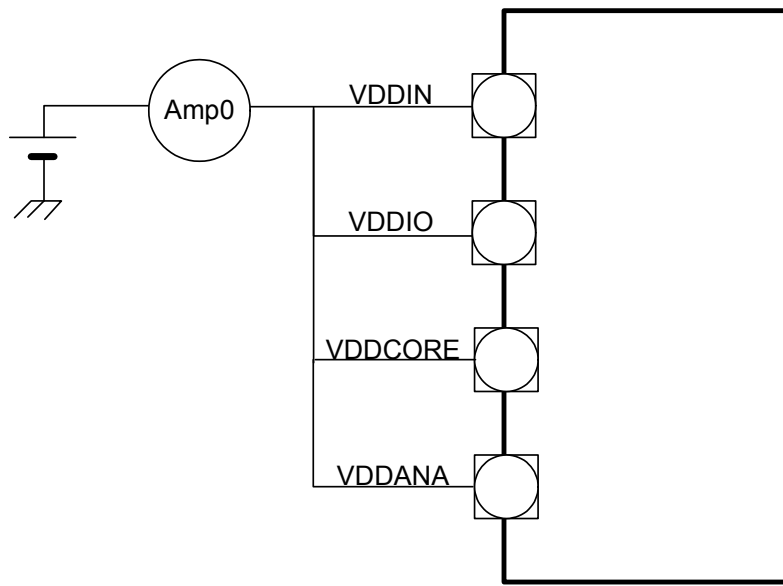

Figure 7-2. Measurement Schematic, External Core Supply



7.5 I/O Pin Characteristics

Table 7-6. Normal I/O Pin Characteristics⁽¹⁾

Symbol	Parameter	Condition	Min	Typ	Max	Units
R _{PULLUP}	Pull-up resistance		75	100	145	kOhm
V _{IL}	Input low-level voltage	V _{VDD} = 3.0V	-0.3		0.3 * V _{VDD}	V
		V _{VDD} = 1.62V	-0.3		0.3 * V _{VDD}	
V _{IH}	Input high-level voltage	V _{VDD} = 3.6V	0.7 * V _{VDD}		V _{VDD} + 0.3	V
		V _{VDD} = 1.98V	0.7 * V _{VDD}		V _{VDD} + 0.3	
V _{OL}	Output low-level voltage	V _{VDD} = 3.0V, I _{OL} = 3mA			0.4	V
		V _{VDD} = 1.62V, I _{OL} = 2mA			0.4	
V _{OH}	Output high-level voltage	V _{VDD} = 3.0V, I _{OH} = 3mA	V _{VDD} - 0.4			V
		V _{VDD} = 1.62V, I _{OH} = 2mA	V _{VDD} - 0.4			
f _{MAX}	Output frequency ⁽²⁾	V _{VDD} = 3.0V, load = 10pF			45	MHz
		V _{VDD} = 3.0V, load = 30pF			23	
t _{RISE}	Rise time ⁽²⁾	V _{VDD} = 3.0V, load = 10pF			4.7	ns
		V _{VDD} = 3.0V, load = 30pF			11.5	
t _{FALL}	Fall time ⁽²⁾	V _{VDD} = 3.0V, load = 10pF			4.8	
		V _{VDD} = 3.0V, load = 30pF			12	
I _{LEAK}	Input leakage current	Pull-up resistors disabled			1	μA
C _{IN}	Input capacitance, all normal I/O pins except PA05, PA07, PA17, PA20, PA21, PB04, PB05	TQFP48 package		1.4		pF
		QFN48 package		1.1		
		TLLGA48 package		1.1		
C _{IN}	Input capacitance, PA20	TQFP48 package		2.7		
		QFN48 package		2.4		
		TLLGA48		2.4		
C _{IN}	Input capacitance, PA05, PA07, PA17, PA21, PB04, PB05	TQFP48 package		3.8		
		QFN48 package		3.5		
		TLLGA48 package		3.5		

- Notes: 1. V_{VDD} corresponds to either V_{VDDIN} or V_{VDDIO}, depending on the supply for the pin. Refer to [Section on page 10](#) for details.
 2. These values are based on simulation and characterization of other AVR microcontrollers manufactured in the same process technology. These values are not covered by test limits in production.

Table 7-7. High-drive I/O Pin Characteristics⁽¹⁾

Symbol	Parameter	Condition	Min	Typ	Max	Units
R _{PULLUP}	Pull-up resistance	PA06	30	50	110	kOhm
		PA02, PB01, RESET	75	100	145	
		PA08, PA09	10	20	45	

Table 7-7. High-drive I/O Pin Characteristics⁽¹⁾

Symbol	Parameter	Condition	Min	Typ	Max	Units
V _{IL}	Input low-level voltage	V _{VDD} = 3.0V	-0.3		0.3 * V _{VDD}	V
		V _{VDD} = 1.62V	-0.3		0.3 * V _{VDD}	
V _{IH}	Input high-level voltage	V _{VDD} = 3.6V	0.7 * V _{VDD}		V _{VDD} + 0.3	V
		V _{VDD} = 1.98V	0.7 * V _{VDD}		V _{VDD} + 0.3	
V _{OL}	Output low-level voltage	V _{VDD} = 3.0V, I _{OL} = 6mA			0.4	V
		V _{VDD} = 1.62V, I _{OL} = 4mA			0.4	
V _{OH}	Output high-level voltage	V _{VDD} = 3.0V, I _{OH} = 6mA	V _{VDD} - 0.4			V
		V _{VDD} = 1.62V, I _{OH} = 4mA	V _{VDD} - 0.4			
f _{MAX}	Output frequency, all High-drive I/O pins, except PA08 and PA09 ⁽²⁾	V _{VDD} = 3.0V, load = 10pF			45	MHz
		V _{VDD} = 3.0V, load = 30pF			23	
t _{RISE}	Rise time, all High-drive I/O pins, except PA08 and PA09 ⁽²⁾	V _{VDD} = 3.0V, load = 10pF			4.7	ns
		V _{VDD} = 3.0V, load = 30pF			11.5	
t _{FALL}	Fall time, all High-drive I/O pins, except PA08 and PA09 ⁽²⁾	V _{VDD} = 3.0V, load = 10pF			4.8	ns
		V _{VDD} = 3.0V, load = 30pF			12	
f _{MAX}	Output frequency, PA08 and PA09 ⁽²⁾	V _{VDD} = 3.0V, load = 10pF			54	MHz
		V _{VDD} = 3.0V, load = 30pF			40	
t _{RISE}	Rise time, PA08 and PA09 ⁽²⁾	V _{VDD} = 3.0V, load = 10pF			2.8	ns
		V _{VDD} = 3.0V, load = 30pF			4.9	
t _{FALL}	Fall time, PA08 and PA09 ⁽²⁾	V _{VDD} = 3.0V, load = 10pF			2.4	ns
		V _{VDD} = 3.0V, load = 30pF			4.6	
I _{LEAK}	Input leakage current	Pull-up resistors disabled			1	μA
C _{IN}	Input capacitance, all High-drive I/O pins, except PA08 and PA09	TQFP48 package		2,2		pF
		QFN48 package		2.0		
		TLLGA48		2.0		
C _{IN}	Input capacitance, PA08 and PA09	TQFP48 package		7.0		pF
		QFN48 package		6.7		
		TLLGA48 package		6.7		

Notes: 1. V_{VDD} corresponds to either V_{VDDIN} or V_{VDDIO}, depending on the supply for the pin. Refer to [Section on page 10](#) for details.
 2. These values are based on simulation and characterization of other AVR microcontrollers manufactured in the same process technology. These values are not covered by test limits in production.

Table 7-8. High-drive I/O, 5V Tolerant, Pin Characteristics⁽¹⁾

Symbol	Parameter	Condition	Min	Typ	Max	Units
R _{PULLUP}	Pull-up resistance		30	50	110	kOhm
V _{IL}	Input low-level voltage	V _{VDD} = 3.0V	-0.3		0.3 * V _{VDD}	V
		V _{VDD} = 1.62V	-0.3		0.3 * V _{VDD}	

Table 7-8. High-drive I/O, 5V Tolerant, Pin Characteristics⁽¹⁾

Symbol	Parameter	Condition	Min	Typ	Max	Units
V _{IH}	Input high-level voltage	V _{VDD} = 3.6V	0.7 * V _{VDD}		5.5	V
		V _{VDD} = 1.98V	0.7 * V _{VDD}		5.5	
V _{OL}	Output low-level voltage	V _{VDD} = 3.0V, I _{OL} = 6mA			0.4	V
		V _{VDD} = 1.62V, I _{OL} = 4mA			0.4	
V _{OH}	Output high-level voltage	V _{VDD} = 3.0V, I _{OH} = 6mA	V _{VDD} - 0.4			V
		V _{VDD} = 1.62V, I _{OH} = 4mA	V _{VDD} - 0.4			
f _{MAX}	Output frequency ⁽²⁾	V _{VDD} = 3.0V, load = 10pF			87	MHz
		V _{VDD} = 3.0V, load = 30pF			58	
t _{RISE}	Rise time ⁽²⁾	V _{VDD} = 3.0V, load = 10pF			2.3	ns
		V _{VDD} = 3.0V, load = 30pF			4.3	
t _{FALL}	Fall time ⁽²⁾	V _{VDD} = 3.0V, load = 10pF			1.9	
		V _{VDD} = 3.0V, load = 30pF			3.7	
I _{LEAK}	Input leakage current	5.5V, pull-up resistors disabled			10	μA
C _{IN}	Input capacitance	TQFP48 package		4.5		pF
		QFN48 package		4.2		
		TLLGA48 package		4.2		

Notes: 1. V_{VDD} corresponds to either V_{VDDIN} or V_{VDDIO}, depending on the supply for the pin. Refer to [Section on page 10](#) for details.
 2. These values are based on simulation and characterization of other AVR microcontrollers manufactured in the same process technology. These values are not covered by test limits in production.

Table 7-9. TWI Pin Characteristics⁽¹⁾

Symbol	Parameter	Condition	Min	Typ	Max	Units
R _{PULLUP}	Pull-up resistance		25	35	60	kOhm
V _{IL}	Input low-level voltage	V _{VDD} = 3.0V	-0.3		0.3 * V _{VDD}	V
		V _{VDD} = 1.62V	-0.3		0.3 * V _{VDD}	
V _{IH}	Input high-level voltage	V _{VDD} = 3.6V	0.7 * V _{VDD}		V _{VDD} + 0.3	V
		V _{VDD} = 1.98V	0.7 * V _{VDD}		V _{VDD} + 0.3	
	Input high-level voltage, 5V tolerant SMBUS compliant pins	V _{VDD} = 3.6V	0.7 * V _{VDD}		5.5	V
		V _{VDD} = 1.98V	0.7 * V _{VDD}		5.5	
V _{OL}	Output low-level voltage	I _{OL} = 3mA			0.4	V
I _{LEAK}	Input leakage current	Pull-up resistors disabled			1	μA
I _{IL}	Input low leakage				1	
I _{IH}	Input high leakage				1	
C _{IN}	Input capacitance	TQFP48 package		3.8		pF
		QFN48 package		3.5		
		TLLGA48 package		3.5		

Table 7-9. TWI Pin Characteristics⁽¹⁾

Symbol	Parameter	Condition	Min	Typ	Max	Units
t _{FALL}	Fall time	Cbus = 400pF, V _{VDD} > 2.0V		250		ns
		Cbus = 400pF, V _{VDD} > 1.62V		470		
f _{MAX}	Max frequency	Cbus = 400pF, V _{VDD} > 2.0V	400			kHz

Note: 1. V_{VDD} corresponds to either V_{VDDIN} or V_{VDDIO}, depending on the supply for the pin. Refer to [Section on page 10](#) for details.

7.6 Oscillator Characteristics

7.6.1 Oscillator 0 (OSC0) Characteristics

7.6.1.1 Digital Clock Characteristics

The following table describes the characteristics for the oscillator when a digital clock is applied on XIN.

Table 7-10. Digital Clock Characteristics

Symbol	Parameter	Conditions	Min	Typ	Max	Units
f _{CPXIN}	XIN clock frequency				50	MHz
t _{CPXIN}	XIN clock duty cycle ⁽¹⁾		40		60	%
t _{STARTUP}	Startup time			0		cycles
C _{IN}	XIN input capacitance	TQFP48 package		7.0		pF
		QFN48 package		6.7		
		TLLGA48 package		6.7		

Note: 1. These values are based on simulation and characterization of other AVR microcontrollers manufactured in the same process technology. These values are not covered by test limits in production.

7.6.1.2 Crystal Oscillator Characteristics

The following table describes the characteristics for the oscillator when a crystal is connected between XIN and XOUT as shown in [Figure 7-3](#). The user must choose a crystal oscillator where the crystal load capacitance C_L is within the range given in the table. The exact value of C_L can be found in the crystal datasheet. The capacitance of the external capacitors (C_{LEXT}) can then be computed as follows:

$$C_{LEXT} = 2(C_L - C_i) - C_{PCB}$$

where C_{PCB} is the capacitance of the PCB and C_i is the internal equivalent load capacitance.

Table 7-11. Crystal Oscillator Characteristics

Symbol	Parameter	Conditions	Min	Typ	Max	Unit
f _{OUT}	Crystal oscillator frequency ⁽³⁾		0.45	10	16	MHz
C _L	Crystal load capacitance ⁽³⁾		6		18	pF
C _i	Internal equivalent load capacitance			2		

Table 7-11. Crystal Oscillator Characteristics

Symbol	Parameter	Conditions	Min	Typ	Max	Unit
$t_{STARTUP}$	Startup time	SCIF.OSCCTRL.GAIN = 2 ⁽¹⁾		30 000 ⁽²⁾		cycles
I_{OSC}	Current consumption	Active mode, $f = 0.45\text{MHz}$, SCIF.OSCCTRL.GAIN = 0		30		μA
		Active mode, $f = 10\text{MHz}$, SCIF.OSCCTRL.GAIN = 2		220		

- Notes:
1. Please refer to the SCIF chapter for details.
 2. Nominal crystal cycles.
 3. These values are based on simulation and characterization of other AVR microcontrollers manufactured in the same process technology. These values are not covered by test limits in production.

Figure 7-3. Oscillator Connection

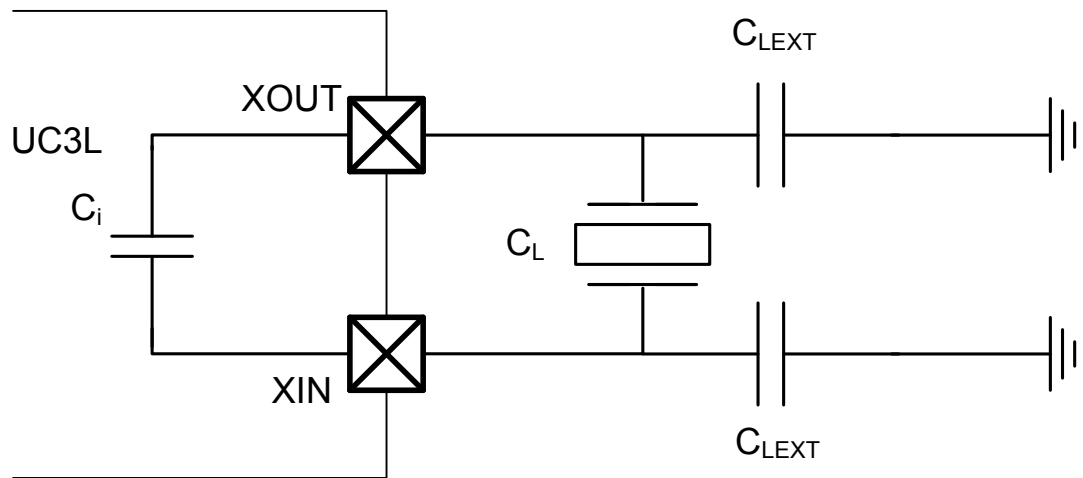

7.6.2 32KHz Crystal Oscillator (OSC32K) Characteristics

Figure 7-3 and the equation above also applies to the 32KHz oscillator connection. The user must choose a crystal oscillator where the crystal load capacitance C_L is within the range given in the table. The exact value of C_L can then be found in the crystal datasheet.

Table 7-12. 32 KHz Crystal Oscillator Characteristics

Symbol	Parameter	Conditions	Min	Typ	Max	Unit
f_{OUT}	Crystal oscillator frequency			32 768		Hz
$t_{STARTUP}$	Startup time	$R_S = 60\text{k}\Omega$, $C_L = 9\text{pF}$		30 000 ⁽¹⁾		cycles
C_L	Crystal load capacitance ⁽²⁾		6		12.5	pF
C_i	Internal equivalent load capacitance			2		
I_{OSC32}	Current consumption			0.6		μA
R_S	Equivalent series resistance ⁽²⁾	32 768Hz	35		85	$\text{k}\Omega$

- Notes:
1. Nominal crystal cycles.
 2. These values are based on simulation and characterization of other AVR microcontrollers manufactured in the same process technology. These values are not covered by test limits in production.

7.6.3 Phase Locked Loop (PLL) Characteristics

Table 7-13. Phase Locked Loop Characteristics

Symbol	Parameter	Conditions	Min	Typ	Max	Unit
f_{OUT}	Output frequency ⁽¹⁾		40		240	MHz
f_{IN}	Input frequency ⁽¹⁾		4		16	
I_{PLL}	Current consumption			8		μA/MHz
$t_{STARTUP}$	Startup time, from enabling the PLL until the PLL is locked	$f_{IN} = 4\text{ MHz}$		200		μs
		$f_{IN} = 16\text{ MHz}$		155		

- Note:
1. These values are based on simulation and characterization of other AVR microcontrollers manufactured in the same process technology. These values are not covered by test limits in production.

7.6.4 Digital Frequency Locked Loop (DFLL) Characteristics

Table 7-14. Digital Frequency Locked Loop Characteristics

Symbol	Parameter	Conditions	Min	Typ	Max	Unit
f_{OUT}	Output frequency ⁽²⁾		20		150	MHz
f_{REF}	Reference frequency ⁽²⁾		8		150	kHz
	FINE resolution step	FINE > 100, all COARSE values ⁽³⁾		0.38		%
	Frequency drift over voltage and temperature	Open loop mode		See Figure 7-4		
	Accuracy ⁽²⁾	FINE lock, $f_{REF} = 32\text{ kHz}$, SSG disabled		0.1	0.5	%
		ACCURATE lock, $f_{REF} = 32\text{ kHz}$, dither clk RCSYS/2, SSG disabled		0.06	0.5	
		FINE lock, $f_{REF} = 8\text{-}150\text{ kHz}$, SSG disabled		0.2	1	
		ACCURATE lock, $f_{REF} = 8\text{-}150\text{ kHz}$, dither clk RCSYS/2, SSG disabled		0.1	1	
I_{DFLL}	Power consumption			25		μA/MHz
$t_{STARTUP}$	Startup time ⁽²⁾	Within 90% of final values			100	μs
t_{LOCK}	Lock time	$f_{REF} = 32\text{ kHz}$, FINE lock, SSG disabled		8		ms
		$f_{REF} = 32\text{ kHz}$, ACCURATE lock, dithering clock = RCSYS/2, SSG disabled		28		

- Notes:
1. Spread Spectrum Generator (SSG) is disabled by writing a zero to the EN bit in the DFLL0SSG register.
 2. These values are based on simulation and characterization of other AVR microcontrollers manufactured in the same process technology. These values are not covered by test limits in production.
 3. The FINE and COARSE values are selected by writing to the DFLL0VAL.FINE and DFLL0VAL.COARSE field respectively.

Figure 7-4. DFLL Open Loop Frequency Variation⁽¹⁾⁽²⁾

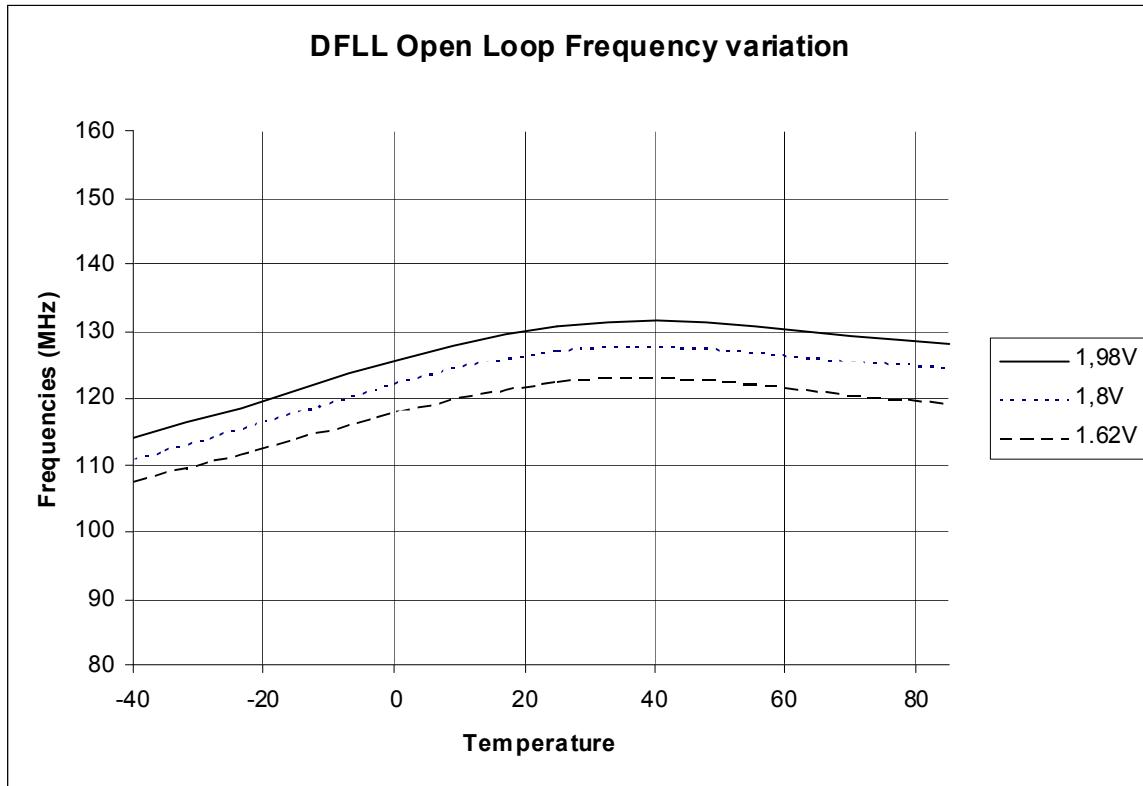

- Notes:
1. The plot shows a typical open loop mode behavior with COARSE= 99 and FINE= 255.
 2. These values are based on simulation and characterization of other AVR microcontrollers manufactured in the same process technology. These values are not covered by test limits in production.

7.6.5 120MHz RC Oscillator (RC120M) Characteristics

Table 7-15. Internal 120MHz RC Oscillator Characteristics

Symbol	Parameter	Conditions	Min	Typ	Max	Unit
f_{OUT}	Output frequency ⁽¹⁾		88	120	152	MHz
I_{RC120M}	Current consumption			1.2		mA
$t_{STARTUP}$	Startup time ⁽¹⁾	$V_{VDDCORE} = 1.8V$		3		μs

- Note:
1. These values are based on simulation and characterization of other AVR microcontrollers manufactured in the same process technology. These values are not covered by test limits in production.

7.6.6 32kHz RC Oscillator (RC32K) Characteristics

Table 7-16. 32kHz RC Oscillator Characteristics

Symbol	Parameter	Conditions	Min	Typ	Max	Unit
f_{OUT}	Output frequency ⁽¹⁾		20	32	44	kHz
I_{RC32K}	Current consumption			0.7		μA
$t_{STARTUP}$	Startup time ⁽¹⁾			100		μs

Note: 1. These values are based on simulation and characterization of other AVR microcontrollers manufactured in the same process technology. These values are not covered by test limits in production.

7.6.7 System RC Oscillator (RCSYS) Characteristics

Table 7-17. System RC Oscillator Characteristics

Symbol	Parameter	Conditions	Min	Typ	Max	Unit
f_{OUT}	Output frequency	Calibrated at 85°C	111.6	115	118.4	kHz

7.7 Flash Characteristics

Table 7-18 gives the device maximum operating frequency depending on the number of flash wait states and the flash read mode. The FSW bit in the FLASHCDW FSR register controls the number of wait states used when accessing the flash memory.

Table 7-18. Maximum Operating Frequency

Flash Wait States	Read Mode	Maximum Operating Frequency
1	High speed read mode	50MHz
0		25MHz
1	Normal read mode	30MHz
0		15MHz

Table 7-19. Flash Characteristics

Symbol	Parameter	Conditions	Min	Typ	Max	Unit
t_{FPP}	Page programming time	$f_{CLK_HSB} = 50MHz$		5		ms
t_{FPE}	Page erase time			5		
t_{FFP}	Fuse programming time			1		
t_{FEA}	Full chip erase time (EA)			6		
t_{FCE}	JTAG chip erase time (CHIP_ERASE)	$f_{CLK_HSB} = 115kHz$		310		

Table 7-20. Flash Endurance and Data Retention

Symbol	Parameter	Conditions	Min	Typ	Max	Unit
N_{FARRAY}	Array endurance (write/page)		100k			cycles
N_{FFUSE}	General Purpose fuses endurance (write/bit)		10k			
t_{RET}	Data retention		15			years

7.8 ABDACB Electrical Characteristics.

Table 7-21. ABDACB Electrical Characteristics

Symbol	Parameter	Conditions	MIN	TYP	MAX	Unit
	Resolution			16		Bits
	Dynamic range ⁽¹⁾⁽²⁾⁽³⁾	$F_S = 48.000\text{kHz}$	> 76			dB
	SNR ⁽¹⁾⁽²⁾⁽³⁾	$F_S = 48.000\text{kHz}$	> 46			dB
	THD ⁽¹⁾⁽²⁾⁽³⁾	$F_S = 48.000\text{kHz}$	< 0.02			%
	PSRR			0		dB
	V_{Out} maximum	CR.CMOC = 0		$97/128 * VDDIO$		V
	V_{Out} minimum	CR.CMOC = 0		$31/128 * VDDIO$		V
	Common mode	CR.CMOC = 0 CR.CMOC = 1, DAC_0 and DAC_1 pins CR.CMOC = 1, DACN_0 and DACN_1 pins		$64/128 * VDDIO$ $80/128 * VDDIO$ $48/128 * VDDIO$		V

- Notes:
1. Test Condition: Common Mode Offset Control disabled (CR.CMOC = 0). Alternative Upsampling Ratio disabled (CR.ALTUPR = 0). Volume at maximum level (VCR0.VOLUME = 0x7FFF and VCR1.VOLUME = 0x7FFF). Device is battery powered (9V) through an LDO, VDDIO at 3.3V. Analog low pass filter as shown in Figure 7-5(1. order differential low pass filter followed by a 4. order low-pass), +VCC at +9V and -VCC at -9V. Test signal stored on a SD card and read by the SPI Interface.
 2. Performance numbers for dynamic range, SNR, and THD performance are very dependent on the application and circuit board design. Since the design has 0dB Power Supply Rejection Ratio (PSRR), noise on the IO power supply will couple directly through to the output and be present in the audio signal. To get the best performance one should reduce toggling of other IO pins as much as possible and make sure the device has sufficient decoupling on the IO supply pins.
 3. These values are based on simulation and characterization of other AVR microcontrollers manufactured in the same process technology. These values are not covered by test limits in production.

Figure 7-5. Differential Analog Low-pass Filter

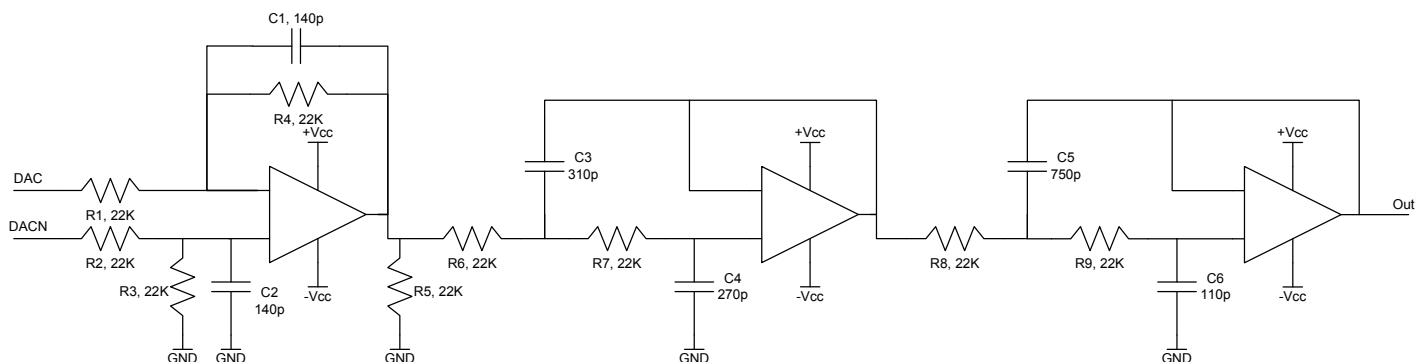

7.9 Analog Characteristics

7.9.1 Voltage Regulator Characteristics

Table 7-22. VREG Electrical Characteristics

Symbol	Parameter	Condition	Min	Typ	Max	Units
V _{VDDIN}	Input voltage range		1.98	3.3	3.6	V
V _{VDDCORE}	Output voltage, calibrated value	V _{VDDIN} ≥ 1.98V		1.8		
	Output voltage accuracy ⁽¹⁾	I _{OUT} = 0.1 mA to 60 mA, V _{VDDIN} > 1.98V		2		%
		I _{OUT} = 0.1 mA to 60 mA, V _{VDDIN} < 1.98V		4		
I _{OUT}	DC output current ⁽¹⁾	Normal mode			60	mA
		Low power mode			1	
I _{VREG}	Static current of internal regulator	Normal mode		13		μA
		Low power mode		4		

Note: 1. These values are based on simulation and characterization of other AVR microcontrollers manufactured in the same process technology. These values are not covered by test limits in production.

Table 7-23. Decoupling Requirements

Symbol	Parameter	Condition	Typ	Techno.	Units
C _{IN1}	Input regulator capacitor 1		33		nF
C _{IN2}	Input regulator capacitor 2		100		
C _{IN3}	Input regulator capacitor 3		10		μF
C _{OUT1}	Output regulator capacitor 1		100		nF
C _{OUT2}	Output regulator capacitor 2		2.2	Tantalum 0.5<ESR<10Ohm	μF

Note: 1. Refer to [Section 5.1.2 on page 25](#).

7.9.2 Power-on Reset 18 Characteristics

Table 7-24. POR18 Characteristics

Symbol	Parameter	Condition	Min	Typ	Max	Units
V_{POT+}	Voltage threshold on $V_{VDDCORE}$ rising			1.45	1.58	V
V_{POT-}	Voltage threshold on $V_{VDDCORE}$ falling		1.2	1.32		
t_{DET}	Detection time ⁽¹⁾	Time with $V_{VDDCORE} < V_{POT-}$ necessary to generate a reset signal		460		μs
I_{POR18}	Current consumption			4		μA
$t_{STARTUP}$	Startup time ⁽¹⁾			6		μs

Note: 1. These values are based on simulation and characterization of other AVR microcontrollers manufactured in the same process technology. These values are not covered by test limits in production.

Figure 7-6. POR18 Operating Principle

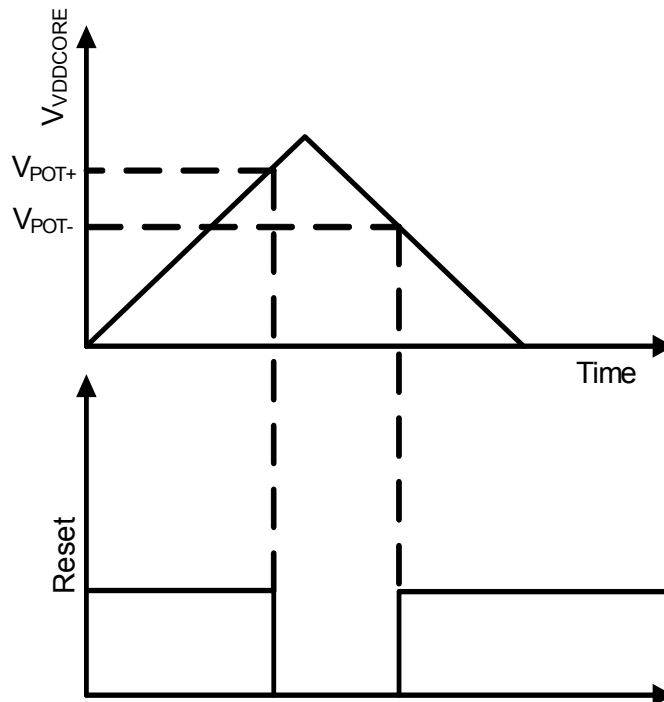

7.9.3 Power-on Reset 33 Characteristics

Table 7-25. POR33 Characteristics

Symbol	Parameter	Condition	Min	Typ	Max	Units
V_{POT+}	Voltage threshold on V_{DDIN} rising			1.49	1.58	V
V_{POT-}	Voltage threshold on V_{DDIN} falling		1.3	1.45		
t_{DET}	Detection time ⁽¹⁾	Time with $V_{DDIN} < V_{POT-}$ necessary to generate a reset signal		460		μs
I_{POR33}	Current consumption			20		μA
$t_{STARTUP}$	Startup time ⁽¹⁾			400		μs

Note: 1. These values are based on simulation and characterization of other AVR microcontrollers manufactured in the same process technology. These values are not covered by test limits in production.

Figure 7-7. POR33 Operating Principle

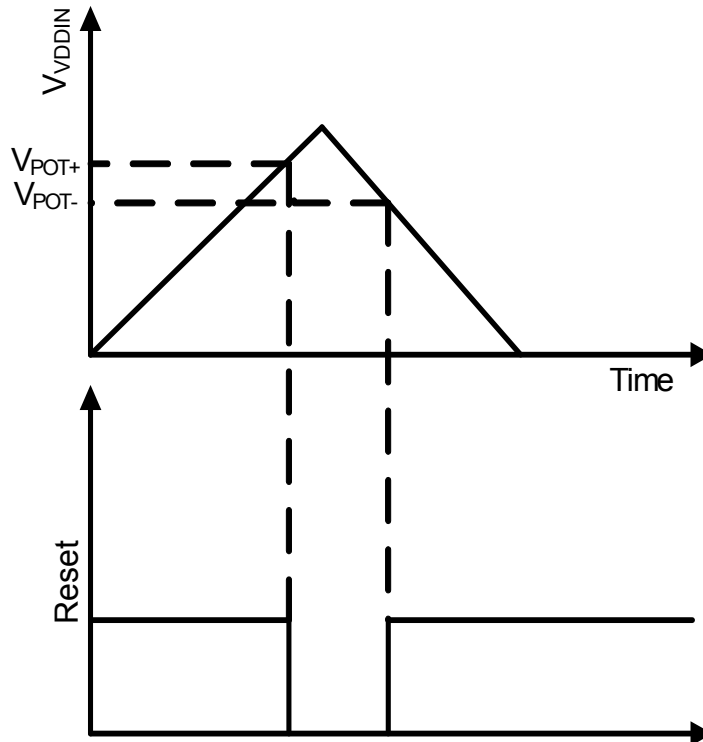

7.9.4 Brown Out Detector Characteristics

The values in [Table 7-26](#) describe the values of the BODLEVEL in the flash General Purpose Fuse register.

Table 7-26. BODLEVEL Values

BODLEVEL Value	Min	Typ	Max	Units
011111 binary (31) 0x1F		1.60		V
100111 binary (39) 0x27		1.69		

Table 7-27. BOD Characteristics

Symbol	Parameter	Condition	Min	Typ	Max	Units
V_{HYST}	BOD hysteresis	$T = 25^{\circ}\text{C}$		10		mV
t_{DET}	Detection time	Time with $V_{DDCORE} < \text{BODLEVEL}$ necessary to generate a reset signal		1		μs
I_{BOD}	Current consumption			7		μA
$t_{STARTUP}$	Startup time			5		μs

7.9.5 Supply Monitor 33 Characteristics

Table 7-28. SM33 Characteristics

Symbol	Parameter	Condition	Min	Typ	Max	Units
V_{TH}	Voltage threshold	Calibrated ⁽¹⁾ , $T = 25^{\circ}\text{C}$	1.675	1.75	1.825	V
	Step size, between adjacent values in SCIF.SM33.CALIB ⁽²⁾			11		mV
V_{HYST}	Hysteresis ⁽²⁾			30		
t_{DET}	Detection time	Time with $V_{DDIN} < V_{TH}$ necessary to generate a reset signal		280		μs
I_{SM33}	Current consumption	Normal mode		17		μA
$t_{STARTUP}$	Startup time	Normal mode		140		μs

- Notes:
1. Calibration value can be read from the SM33.CALIB field. This field is updated by the flash fuses after a reset. Refer to SCIF chapter for details.
 2. These values are based on simulation and characterization of other AVR microcontrollers manufactured in the same process technology. These values are not covered by test limits in production.

7.9.6 Analog to Digital Converter Characteristics

Table 7-29. ADC Characteristics

Symbol	Parameter	Conditions	Min	Typ	Max	Units
f_{ADC}	ADC clock frequency	12-bit resolution mode			6	MHz
		10-bit resolution mode			6	
		8-bit resolution mode			6	
$t_{STARTUP}$	Startup time	Return from Idle Mode		15		μ s
t_{CONV}	Conversion time (latency)	$f_{ADC} = 6\text{MHz}$	11		26	cycles
	Throughput rate	$V_{VDD} > 3.0\text{V}$, $f_{ADC} = 6\text{MHz}$, 12-bit resolution mode, low impedance source			28	kSPS
		$V_{VDD} > 3.0\text{V}$, $f_{ADC} = 6\text{MHz}$, 10-bit resolution mode, low impedance source			460	
		$V_{VDD} > 3.0\text{V}$, $f_{ADC} = 6\text{MHz}$, 8-bit resolution mode, low impedance source			460	
$V_{ADVREFP}$	Reference voltage range	$V_{ADVREFP} = V_{VDDANA}$	1.62		1.98	V
I_{ADC}	Current consumption on V_{VDDANA}	ADC Clock = 6MHz		350		μ A
$I_{ADVREFP}$	Current consumption on ADVREFP pin	$f_{ADC} = 6\text{MHz}$		150		

Note: These values are based on simulation and characterization of other AVR microcontrollers manufactured in the same process technology. These values are not covered by test limits in production.

7.9.6.1 Inputs and Sample and Hold Acquisition Times

Table 7-30. Analog Inputs

Symbol	Parameter	Conditions	Min	Typ	Max	Units
V_{ADn}	Input Voltage Range	12-bit mode	0		$V_{ADVREFP}$	V
		10-bit mode				
		8-bit mode				
C_{ONCHIP}	Internal Capacitance ⁽¹⁾				22.5	pF
R_{ONCHIP}	Internal Resistance ⁽¹⁾	$V_{VDDIO} = 3.0\text{V to } 3.6\text{V}$, $V_{VDDCORE} = 1.8\text{V}$			3.15	kOhm
		$V_{VDDIO} = V_{VDDCORE} = 1.62\text{V to } 1.98\text{V}$			55.9	

Note: 1. These values are based on simulation and characterization of other AVR microcontrollers manufactured in the same process technology. These values are not covered by test limits in production.

The analog voltage source must be able to charge the sample and hold (S/H) capacitor in the ADC in order to achieve maximum accuracy. Seen externally the ADC input consists of a resistor (R_{ONCHIP}) and a capacitor (C_{ONCHIP}). In addition, the resistance (R_{SOURCE}) and capacitance

(C_{SOURCE}) of the PCB and source must be taken into account when calculating the required sample and hold time. Figure 7-8 shows the ADC input channel equivalent circuit.

Figure 7-8. ADC Input

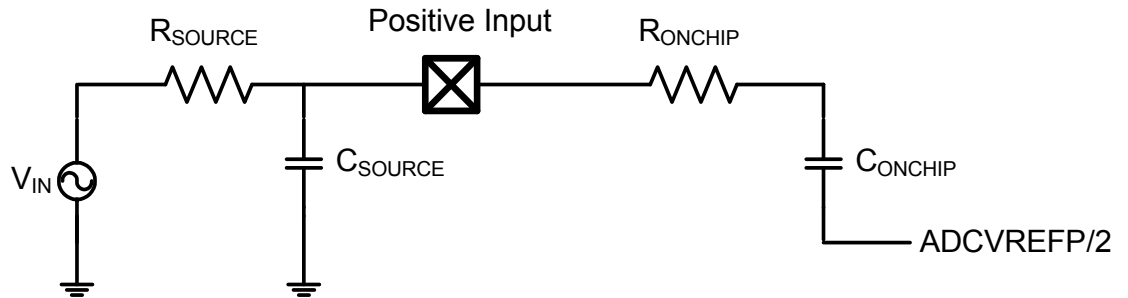

The minimum sample and hold time (in ns) can be found using this formula:

$$t_{SAMPLEHOLD} \geq (R_{ONCHIP} + R_{SOURCE}) \times (C_{ONCHIP} + C_{SOURCE}) \times \ln(2^{n+1})$$

Where n is the number of bits in the conversion. $t_{SAMPLEHOLD}$ is defined by the SHTIM field in the ADCIFB ACR register. Please refer to the ADCIFB chapter for more information.

7.9.6.2 Applicable Conditions and Derating Data

Table 7-31. Transfer Characteristics 12-bit Resolution Mode⁽¹⁾

Parameter	Conditions	Min	Typ	Max	Units
Resolution			12		Bit
Integral non-linearity	ADC clock frequency = 6 MHz, Input Voltage Range = 0 - $V_{ADVREFP}$		+/-4		LSB
	ADC clock frequency = 6 MHz, Input Voltage Range = (10% $V_{ADVREFP}$) - (90% $V_{ADVREFP}$)		+/-2		
Differential non-linearity		-1.5		1.5	
Offset error	ADC clock frequency = 6 MHz		+/-3		
Gain error			+/-5		

Note: 1. These values are based on simulation and characterization of other AVR microcontrollers manufactured in the same process technology. These values are not covered by test limits in production.

Table 7-32. Transfer Characteristics, 10-bit Resolution Mode⁽¹⁾

Parameter	Conditions	Min	Typ	Max	Units
Resolution			10		Bit
Integral non-linearity	ADC clock frequency = 6 MHz		+/-1		LSB
Differential non-linearity		-1.0		1.0	
Offset error			+/-1		
Gain error			+/-2		

Note: 1. These values are based on simulation and characterization of other AVR microcontrollers manufactured in the same process technology. These values are not covered by test limits in production.

Table 7-33. Transfer Characteristics, 8-bit Resolution Mode⁽¹⁾

Parameter	Conditions	Min	Typ	Max	Units
Resolution			8		Bit
Integral non-linearity	ADC clock frequency = 6MHz		+/-0.5		LSB
Differential non-linearity		-0.3		0.3	
Offset error			+/-1		
Gain error			+/-1		

Note: 1. These values are based on simulation and characterization of other AVR microcontrollers manufactured in the same process technology. These values are not covered by test limits in production.

7.9.7 Temperature Sensor Characteristics

Table 7-34. Temperature Sensor Characteristics⁽¹⁾

Symbol	Parameter	Condition	Min	Typ	Max	Units
	Gradient			1		mV/°C
I _{TS}	Current consumption			1		μA
t _{STARTUP}	Startup time			0		μs

Note: 1. The Temperature Sensor is not calibrated. The accuracy of the Temperature Sensor is governed by the ADC accuracy.

7.9.8 Analog Comparator Characteristics

Table 7-35. Analog Comparator Characteristics

Symbol	Parameter	Condition	Min	Typ	Max	Units
	Positive input voltage range ⁽³⁾		-0.2		V _{VDDIO} + 0.3	V
	Negative input voltage range ⁽³⁾		-0.2		V _{VDDIO} - 0.6	
	Statistical offset ⁽³⁾	V _{ACREFN} = 1.0V, f _{AC} = 12MHz, filter length = 2, hysteresis = 0 ⁽¹⁾		20		mV
f _{AC}	Clock frequency for GCLK4 ⁽³⁾				12	MHz
	Throughput rate ⁽³⁾	f _{AC} = 12MHz			12 000 000	Comparisons per second
	Propagation delay	Delay from input change to Interrupt Status Register Changes		$\left(\left\lfloor \frac{1}{t_{CLKACIFB} \times f_{AC}} \right\rfloor + 3 \right) \times t_{CLKACIFB}$		ns
I _{AC}	Current consumption ⁽³⁾	All channels, VDDIO = 3.3V, f _A = 3MHz		420		μA
t _{STARTUP}	Startup time			3		cycles
	Input current per pin ⁽³⁾			0.2		μA/MHz ⁽²⁾

- Notes:
1. AC.CONFn.FLEN and AC.CONFn.HYS fields, refer to the Analog Comparator Interface chapter.
 2. Referring to f_{AC}.
 3. These values are based on simulation and characterization of other AVR microcontrollers manufactured in the same process technology. These values are not covered by test limits in production.

7.9.9 Capacitive Touch Characteristics

7.9.9.1 Discharge Current Source

Table 7-36. DICS Characteristics

Symbol	Parameter	Min	Typ	Max	Unit
R _{REF}	Internal resistor		170		kOhm
k	Trim step size ⁽¹⁾		0.7		%

- Note:
1. These values are based on simulation and characterization of other AVR microcontrollers manufactured in the same process technolo. These values are not covered by test limits in production.

7.9.9.2 Strong Pull-up Pull-down

Table 7-37. Strong Pull-up Pull-down

Parameter	Min	Typ	Max	Unit
Pull-down resistor		1		kOhm
Pull-up resistor		1		

7.9.10 USB Transceiver Characteristics

The USB on-chip buffers comply with the Universal Serial Bus (USB) v2.0 standard. All AC parameters related to these buffers can be found within the USB 2.0 electrical specifications.

7.9.10.1 Electrical Characteristics

Table 7-38. Electrical Parameters

Symbol	Parameter	Conditions	Min	Typ	Max	Unit
R _{EXT}	Recommended external USB series resistor	In series with each USB pin with $\pm 5\%$		39		Ohm

7.10 Timing Characteristics

7.10.1 Startup, Reset, and Wake-up Timing

The startup, reset, and wake-up timings are calculated using the following formula:

$$t = t_{CONST} + N_{CPU} \times t_{CPU}$$

Where t_{CONST} and N_{CPU} are found in [Table 7-39](#). t_{CPU} is the period of the CPU clock. If a clock source other than RCSYS is selected as the CPU clock, the oscillator startup time, $t_{OSCSTART}$, must be added to the wake-up time from the stop, deepstop, and static sleep modes. Please refer to the source for the CPU clock in the ["Oscillator Characteristics"](#) on [page 42](#) for more details about oscillator startup times.

Table 7-39. Maximum Reset and Wake-up Timing⁽¹⁾

Parameter		Measuring	Max t_{CONST} (in μ s)	Max N_{CPU}
Startup time from power-up, using regulator		Time from VDDIN crossing the V_{POT+} threshold of POR33 to the first instruction entering the decode stage of CPU. VDDCORE is supplied by the internal regulator.	2210	0
Startup time from power-up, no regulator		Time from VDDIN crossing the V_{POT+} threshold of POR33 to the first instruction entering the decode stage of CPU. VDDCORE is connected to VDDIN.	1810	0
Startup time from reset release		Time from releasing a reset source (except POR18, POR33, and SM33) to the first instruction entering the decode stage of CPU.	170	0
Wake-up	Idle	From wake-up event to the first instruction of an interrupt routine entering the decode stage of the CPU.	0	19
	Frozen		0	110
	Standby		0	110
	Stop		$27 + t_{OSCSTART}$	116
	Deepstop		$27 + t_{OSCSTART}$	116
	Static		$97 + t_{OSCSTART}$	116
Wake-up from shutdown		From wake-up event to the first instruction entering the decode stage of the CPU.	1180	0

Note: 1. These values are based on simulation and characterization of other AVR microcontrollers manufactured in the same process technology. These values are not covered by test limits in production.

7.10.2 RESET_N Timing

Table 7-40. RESET_N Waveform Parameters⁽¹⁾

Symbol	Parameter	Conditions	Min	Max	Units
t_{RESET}	RESET_N minimum pulse length		10		ns

Note: 1. These values are based on simulation and characterization of other AVR microcontrollers manufactured in the same process technology. These values are not covered by test limits in production.

7.10.3 USART in SPI Mode Timing

7.10.3.1 Master mode

Figure 7-9. USART in SPI Master Mode with (CPOL= CPHA= 0) or (CPOL= CPHA= 1)

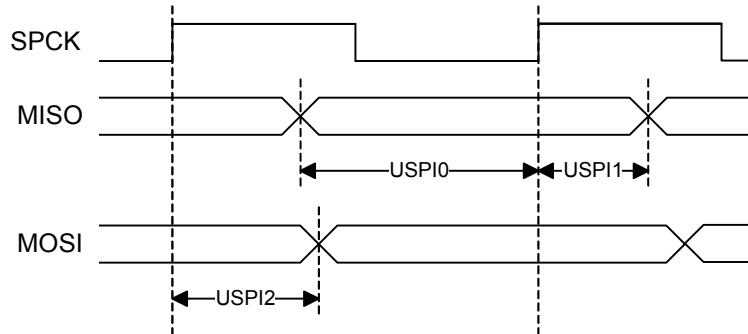

Figure 7-10. USART in SPI Master Mode with (CPOL= 0 and CPHA= 1) or (CPOL= 1 and CPHA= 0)

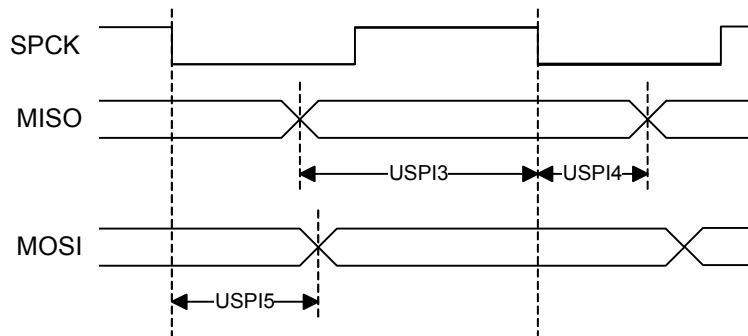

Table 7-41. USART in SPI Mode Timing, Master Mode⁽¹⁾

Symbol	Parameter	Conditions	Min	Max	Units
USPI0	MISO setup time before SPCK rises	V _{VDDIO} from 3.0V to 3.6V, maximum external capacitor = 40pF	28.7 + t _{SAMPLE} ⁽²⁾		ns
USPI1	MISO hold time after SPCK rises		0		
USPI2	SPCK rising to MOSI delay			16.5	
USPI3	MISO setup time before SPCK falls		25.8 + t _{SAMPLE} ⁽²⁾		
USPI4	MISO hold time after SPCK falls		0		
USPI5	SPCK falling to MOSI delay			21.19	

Notes: 1. These values are based on simulation and characterization of other AVR microcontrollers manufactured in the same process technology. These values are not covered by test limits in production.

2. Where: $t_{SAMPLE} = t_{SPCK} - \left(\frac{t_{SPCK}}{2 \times t_{CLKUSART}} \right) \times t_{CLKUSART}$

Maximum SPI Frequency, Master Output

The maximum SPI master output frequency is given by the following formula:

$$f_{SPCKMAX} = \text{MIN}(f_{PINMAX} \cdot \frac{1}{SPI_{in}}, \frac{f_{CLKSPI} \times 2}{9})$$

Where SPI_{in} is the MOSI delay, USPI2 or USPI5 depending on CPOL and NCPHA. f_{PINMAX} is the maximum frequency of the SPI pins. Please refer to the I/O Pin Characteristics section for the maximum frequency of the pins. f_{CLKSPI} is the maximum frequency of the CLK_SPI. Refer to the SPI chapter for a description of this clock.

Maximum SPI Frequency, Master Input

The maximum SPI master input frequency is given by the following formula:

$$f_{SPCKMAX} = \text{MIN}(\frac{1}{SPI_{in} + t_{VALID}}, \frac{f_{CLKSPI} \times 2}{9})$$

Where SPI_{in} is the MISO setup and hold time, USPI0 + USPI1 or USPI3 + USPI4 depending on CPOL and NCPHA. t_{VALID} is the SPI slave response time. Please refer to the SPI slave datasheet for $t_{VALID} \cdot f_{CLKSPI}$ is the maximum frequency of the CLK_SPI. Refer to the SPI chapter for a description of this clock.

7.10.3.2 Slave mode

Figure 7-11. USART in SPI Slave Mode with (CPOL= 0 and CPHA= 1) or (CPOL= 1 and CPHA= 0)

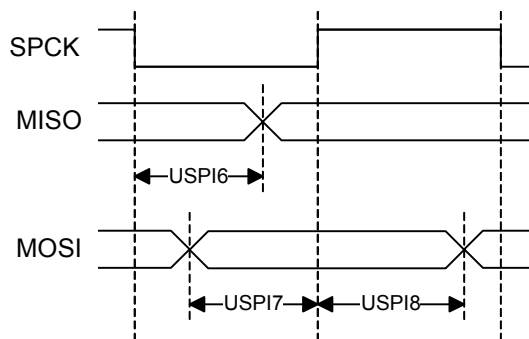

Figure 7-12. USART in SPI Slave Mode with (CPOL= CPHA= 0) or (CPOL= CPHA= 1)

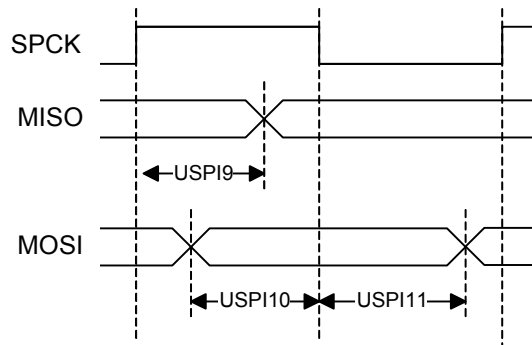

Figure 7-13. USART in SPI Slave Mode, NPCS Timing

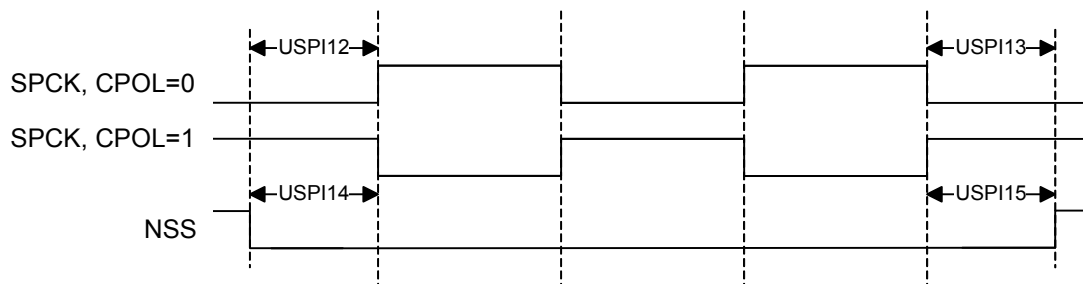

Table 7-42. USART in SPI mode Timing, Slave Mode⁽¹⁾

Symbol	Parameter	Conditions	Min	Max	Units
USPI6	SPCK falling to MISO delay	V _{VDDIO} from 3.0V to 3.6V, maximum external capacitor = 40pF		37.3	ns
USPI7	MOSI setup time before SPCK rises		$2.6 + t_{SAMPLE}^{(2)} + t_{CLK_USART}$		
USPI8	MOSI hold time after SPCK rises		0		
USPI9	SPCK rising to MISO delay			37.0	
USPI10	MOSI setup time before SPCK falls		$2.6 + t_{SAMPLE}^{(2)} + t_{CLK_USART}$		
USPI11	MOSI hold time after SPCK falls		0		
USPI12	NSS setup time before SPCK rises		27.2		
USPI13	NSS hold time after SPCK falls		0		
USPI14	NSS setup time before SPCK falls		27.2		
USPI15	NSS hold time after SPCK rises		0		

Notes: 1. These values are based on simulation and characterization of other AVR microcontrollers manufactured in the same process technology. These values are not covered by test limits in production.

2. Where: $t_{SAMPLE} = t_{SPCK} - \left(\left\lceil \frac{t_{SPCK}}{2 \times t_{CLK_USART}} \right\rceil + \frac{1}{2} \right) \times t_{CLK_USART}$

Maximum SPI Frequency, Slave Input Mode

The maximum SPI slave input frequency is given by the following formula:

$$f_{SPCKMAX} = \text{MIN}\left(\frac{f_{CLKSPI} \times 2}{9}, \frac{1}{SPI_{In}}\right)$$

Where SPI_{In} is the MOSI setup and hold time, USPI7 + USPI8 or USPI10 + USPI11 depending on CPOL and NCPHA. f_{CLKSPI} is the maximum frequency of the CLK_SPI. Refer to the SPI chapter for a description of this clock.

Maximum SPI Frequency, Slave Output Mode

The maximum SPI slave output frequency is given by the following formula:

$$f_{SPCKMAX} = \text{MIN}\left(\frac{f_{CLKSPI} \times 2}{9}, f_{PINMAX} \frac{1}{SPI_{In} + t_{SETUP}}\right)$$

Where SPI_{In} is the MISO delay, USPI6 or USPI9 depending on CPOL and NCPHA. T_{SETUP} is the SPI master setup time. Please refer to the SPI master datasheet for T_{SETUP} . f_{CLKSPI} is the maximum frequency of the CLK_SPI. Refer to the SPI chapter for a description of this clock. f_{PINMAX} is the maximum frequency of the SPI pins. Please refer to the I/O Pin Characteristics section for the maximum frequency of the pins.

7.10.4 SPI Timing

7.10.4.1 Master mode

Figure 7-14. SPI Master Mode with (CPOL= NCPHA= 0) or (CPOL= NCPHA= 1)

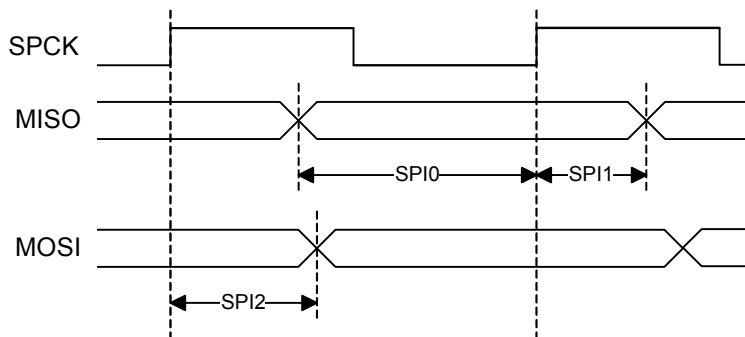

Figure 7-15. SPI Master Mode with (CPOL= 0 and NCPHA= 1) or (CPOL= 1 and NCPHA= 0)

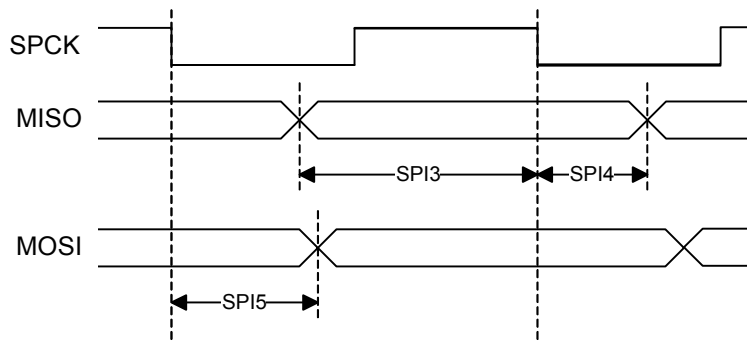

Table 7-43. SPI Timing, Master Mode⁽¹⁾

Symbol	Parameter	Conditions	Min	Max	Units
SPI0	MISO setup time before SPCK rises	V _{VDDIO} from 3.0V to 3.6V, maximum external capacitor = 40pF	33.4 + (t _{CLK_SPI})/2		ns
SPI1	MISO hold time after SPCK rises		0		
SPI2	SPCK rising to MOSI delay			7.1	
SPI3	MISO setup time before SPCK falls		29.2 + (t _{CLK_SPI})/2		
SPI4	MISO hold time after SPCK falls		0		
SPI5	SPCK falling to MOSI delay			8.63	

Note: 1. These values are based on simulation and characterization of other AVR microcontrollers manufactured in the same process technology. These values are not covered by test limits in production.

Maximum SPI Frequency, Master Output

The maximum SPI master output frequency is given by the following formula:

$$f_{SPCKMAX} = \text{MIN}(f_{PINMAX}, \frac{1}{SPI_n})$$

Where SPI_n is the MOSI delay, SPI2 or SPI5 depending on CPOL and NCPHA. f_{PINMAX} is the maximum frequency of the SPI pins. Please refer to the I/O Pin Characteristics section for the maximum frequency of the pins.

Maximum SPI Frequency, Master Input

The maximum SPI master input frequency is given by the following formula:

$$f_{SPCKMAX} = \frac{1}{SPI_n + t_{VALID}}$$

Where SPI_n is the MISO setup and hold time, SPI0 + SPI1 or SPI3 + SPI4 depending on CPOL and NCPHA. t_{VALID} is the SPI slave response time. Please refer to the SPI slave datasheet for t_{VALID} .

7.10.4.2 Slave mode

Figure 7-16. SPI Slave Mode with (CPOL= 0 and NCPHA= 1) or (CPOL= 1 and NCPHA= 0)

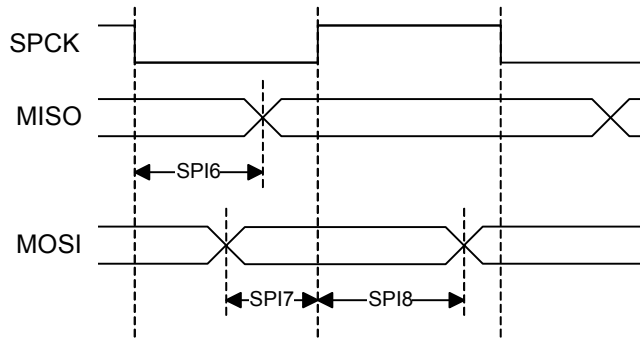

Figure 7-17. SPI Slave Mode with (CPOL= NCPHA= 0) or (CPOL= NCPHA= 1)

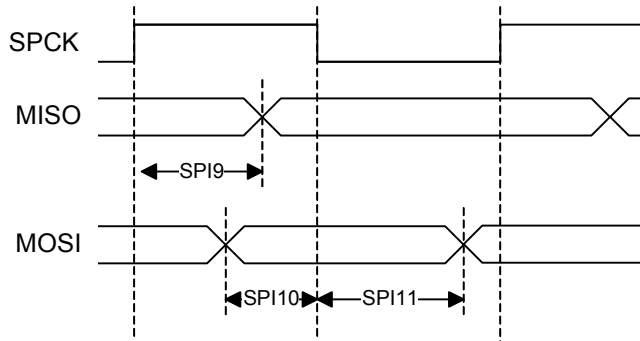

Figure 7-18. SPI Slave Mode, NPCS Timing

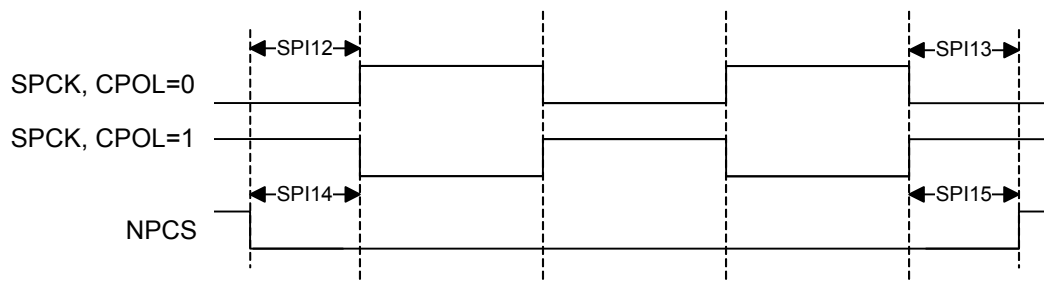

Table 7-44. SPI Timing, Slave Mode⁽¹⁾

Symbol	Parameter	Conditions	Min	Max	Units
SPI6	SPCK falling to MISO delay	V _{VDDIO} from 3.0V to 3.6V, maximum external capacitor = 40pF		29.4	ns
SPI7	MOSI setup time before SPCK rises		0		
SPI8	MOSI hold time after SPCK rises		6.0		
SPI9	SPCK rising to MISO delay			29.0	
SPI10	MOSI setup time before SPCK falls		0		
SPI11	MOSI hold time after SPCK falls		5.5		
SPI12	NPCS setup time before SPCK rises		3.4		
SPI13	NPCS hold time after SPCK falls		1.1		
SPI14	NPCS setup time before SPCK falls		3.3		
SPI15	NPCS hold time after SPCK rises		0.7		

Note: 1. These values are based on simulation and characterization of other AVR microcontrollers manufactured in the same process technology. These values are not covered by test limits in production.

Maximum SPI Frequency, Slave Input Mode

The maximum SPI slave input frequency is given by the following formula:

$$f_{SPCKMAX} = \text{MIN}(f_{CLKSPI}, \frac{1}{SPI_{In}})$$

Where SPI_{In} is the MOSI setup and hold time, SPI7 + SPI8 or SPI10 + SPI11 depending on CPOL and NCPHA. f_{CLKSPI} is the maximum frequency of the CLK_SPI. Refer to the SPI chapter for a description of this clock.

Maximum SPI Frequency, Slave Output Mode

The maximum SPI slave output frequency is given by the following formula:

$$f_{SPCKMAX} = \text{MIN}(f_{PINMAX}, \frac{1}{SPI_{In} + t_{SETUP}})$$

Where SPI_{In} is the MISO delay, SPI6 or SPI9 depending on CPOL and NCPHA. t_{SETUP} is the SPI master setup time. Please refer to the SPI master datasheet for t_{SETUP} . f_{PINMAX} is the maximum frequency of the SPI pins. Please refer to the I/O Pin Characteristics section for the maximum frequency of the pins.

7.10.5 TWIM/TWIS Timing

Figure 7-45 shows the TWI-bus timing requirements and the compliance of the device with them. Some of these requirements (t_r and t_f) are met by the device without requiring user intervention. Compliance with the other requirements (t_{HD-STA} , t_{SU-STA} , t_{SU-STO} , t_{HD-DAT} , $t_{SU-DAT-TWI}$, $t_{LOW-TWI}$, t_{HIGH} , and f_{TWCK}) requires user intervention through appropriate programming of the relevant

TWIM and TWIS user interface registers. Please refer to the TWIM and TWIS sections for more information.

Table 7-45. TWI-Bus Timing Requirements

Symbol	Parameter	Mode	Minimum		Maximum		Unit
			Requirement	Device	Requirement	Device	
t_r	TWCK and TWD rise time	Standard ⁽¹⁾	-		1000		ns
		Fast ⁽¹⁾	$20 + 0.1C_b$		300		
t_f	TWCK and TWD fall time	Standard	-		300		ns
		Fast	$20 + 0.1C_b$		300		
t_{HD-STA}	(Repeated) START hold time	Standard	4	t_{clkpb}	-		μs
		Fast	0.6				
t_{SU-STA}	(Repeated) START set-up time	Standard	4.7	t_{clkpb}	-		μs
		Fast	0.6				
t_{SU-STO}	STOP set-up time	Standard	4.0	$4t_{clkpb}$	-		μs
		Fast	0.6				
t_{HD-DAT}	Data hold time	Standard	$0.3^{(2)}$	$2t_{clkpb}$	$3.45^{(0)}$	$15t_{prescaled} + t_{clkpb}$	μs
		Fast			$0.9^{(0)}$		
$t_{SU-DAT-TWI}$	Data set-up time	Standard	250	$2t_{clkpb}$	-		ns
		Fast	100				
t_{SU-DAT}		-	-	t_{clkpb}	-		-
$t_{LOW-TWI}$	TWCK LOW period	Standard	4.7	$4t_{clkpb}$	-		μs
		Fast	1.3				
t_{LOW}		-	-	t_{clkpb}	-		-
t_{HIGH}	TWCK HIGH period	Standard	4.0	$8t_{clkpb}$	-		μs
		Fast	0.6				
f_{TWCK}	TWCK frequency	Standard	-		100	$\frac{1}{12t_{clkpb}}$	kHz
		Fast			400		

- Notes: 1. Standard mode: $f_{TWCK} \leq 100$ kHz ; fast mode: $f_{TWCK} > 100$ kHz .
 2. A device must internally provide a hold time of at least 300 ns for TWD with reference to the falling edge of TWCK.

Notations:

C_b = total capacitance of one bus line in pF

t_{clkpb} = period of TWI peripheral bus clock

$t_{prescaled}$ = period of TWI internal prescaled clock (see chapters on TWIM and TWIS)

The maximum $t_{HD;DAT}$ has only to be met if the device does not stretch the LOW period ($t_{LOW-TWI}$) of TWCK.

7.10.6 JTAG Timing

Figure 7-19. JTAG Interface Signals

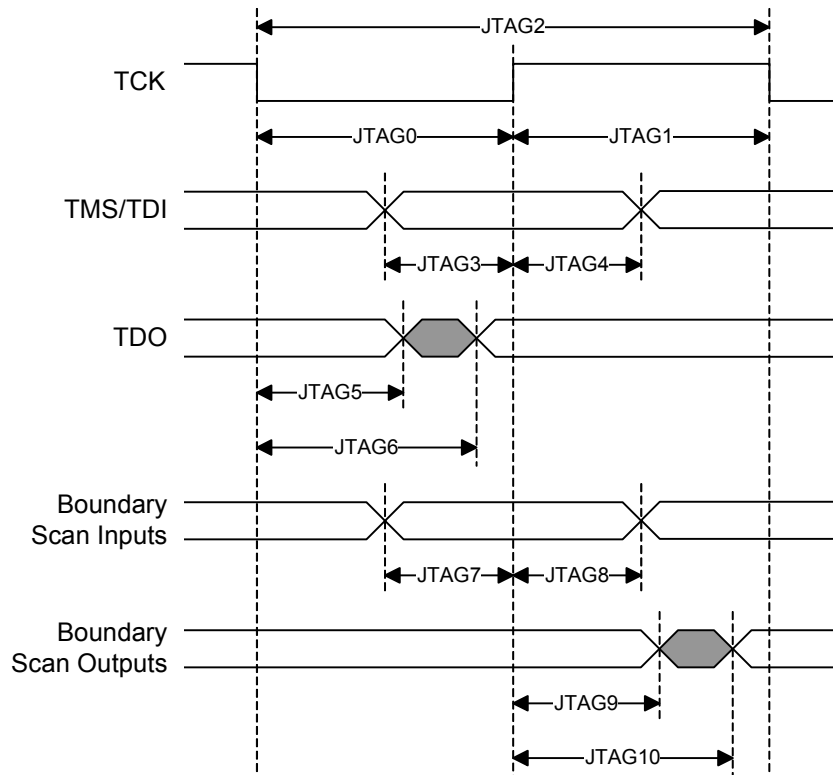

Table 7-46. JTAG Timings⁽¹⁾

Symbol	Parameter	Conditions	Min	Max	Units
JTAG0	TCK Low Half-period	V _{VDDIO} from 3.0V to 3.6V, maximum external capacitor = 40pF	21.8		ns
JTAG1	TCK High Half-period		8.6		
JTAG2	TCK Period		30.3		
JTAG3	TDI, TMS Setup before TCK High		2.0		
JTAG4	TDI, TMS Hold after TCK High		2.3		
JTAG5	TDO Hold Time		9.5		
JTAG6	TCK Low to TDO Valid			21.8	
JTAG7	Boundary Scan Inputs Setup Time		0.6		
JTAG8	Boundary Scan Inputs Hold Time		6.9		
JTAG9	Boundary Scan Outputs Hold Time		9.3		
JTAG10	TCK to Boundary Scan Outputs Valid			32.2	

Note: 1. These values are based on simulation and characterization of other AVR microcontrollers manufactured in the same process technology. These values are not covered by test limits in production.

8. Mechanical Characteristics

8.1 Thermal Considerations

8.1.1 Thermal Data

Table 8-1 summarizes the thermal resistance data depending on the package.

Table 8-1. Thermal Resistance Data

Symbol	Parameter	Condition	Package	Typ	Unit
θ_{JA}	Junction-to-ambient thermal resistance	Still Air	TQFP48	54.4	°C/W
θ_{JC}	Junction-to-case thermal resistance		TQFP48	15.7	
θ_{JA}	Junction-to-ambient thermal resistance	Still Air	QFN48	26.0	°C/W
θ_{JC}	Junction-to-case thermal resistance		QFN48	1.6	
θ_{JA}	Junction-to-ambient thermal resistance	Still Air	TLLGA48	25.4	°C/W
θ_{JC}	Junction-to-case thermal resistance		TLLGA48	12.7	
θ_{JA}	Junction-to-ambient thermal resistance	Still Air	TQFP64	52.9	°C/W
θ_{JC}	Junction-to-case thermal resistance		TQFP64	15.5	
θ_{JA}	Junction-to-ambient thermal resistance	Still Air	QFN64	22.9	°C/W
θ_{JC}	Junction-to-case thermal resistance		QFN64	1.6	

8.1.2 Junction Temperature

The average chip-junction temperature, T_J , in °C can be obtained from the following:

1. $T_J = T_A + (P_D \times \theta_{JA})$
2. $T_J = T_A + (P_D \times (\theta_{HEATSINK} + \theta_{JC}))$

where:

- θ_{JA} = package thermal resistance, Junction-to-ambient (°C/W), provided in [Table 8-1](#).
- θ_{JC} = package thermal resistance, Junction-to-case thermal resistance (°C/W), provided in [Table 8-1](#).
- $\theta_{HEAT SINK}$ = cooling device thermal resistance (°C/W), provided in the device datasheet.
- P_D = device power consumption (W) estimated from data provided in [Section 7.4 on page 35](#).
- T_A = ambient temperature (°C).

From the first equation, the user can derive the estimated lifetime of the chip and decide if a cooling device is necessary or not. If a cooling device is to be fitted on the chip, the second equation should be used to compute the resulting average chip-junction temperature T_J in °C.

8.2 Package Drawings

Figure 8-1. TQFP-48 Package Drawing

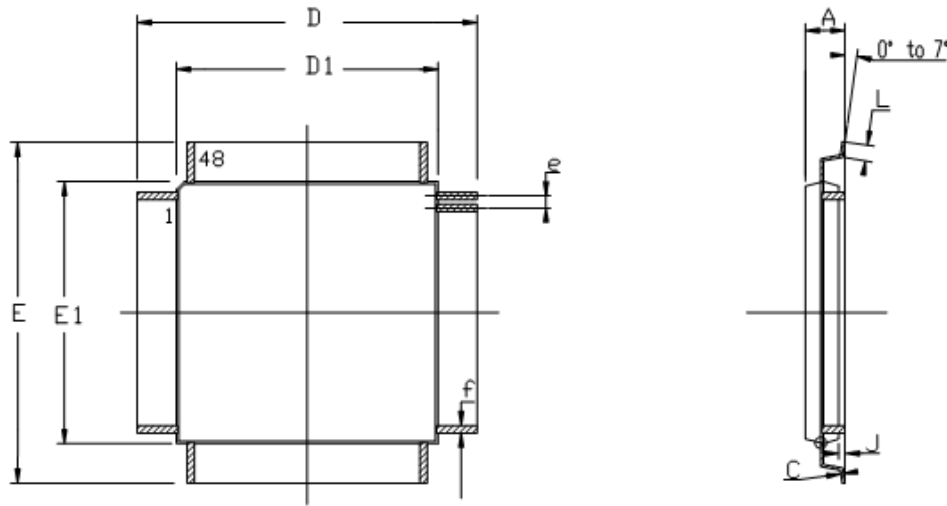

DRAWINGS NOT SCALED

COMMON DIMENSIONS IN MM

SYMBOL	Min	Max	NOTES
A	----	1.20	
A1	0.95	1.05	
C	0.09	0.20	
D	9.00 BSC		
D1	7.00 BSC		
E	9.00 BSC		
E1	7.00 BSC		
J	0.05	0.15	
L	0.45	0.75	
e	0.50 BSC		
f	0.17	0.27	

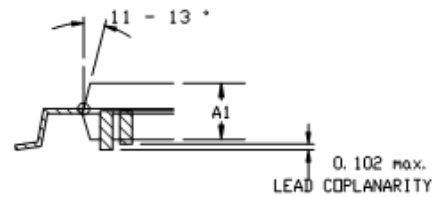

Table 8-2. Device and Package Maximum Weight

140	mg
-----	----

Table 8-3. Package Characteristics

Moisture Sensitivity Level	MSL3
----------------------------	------

Table 8-4. Package Reference

JEDEC Drawing Reference	MS-026
JESD97 Classification	E3

Figure 8-2. QFN-48 Package Drawing

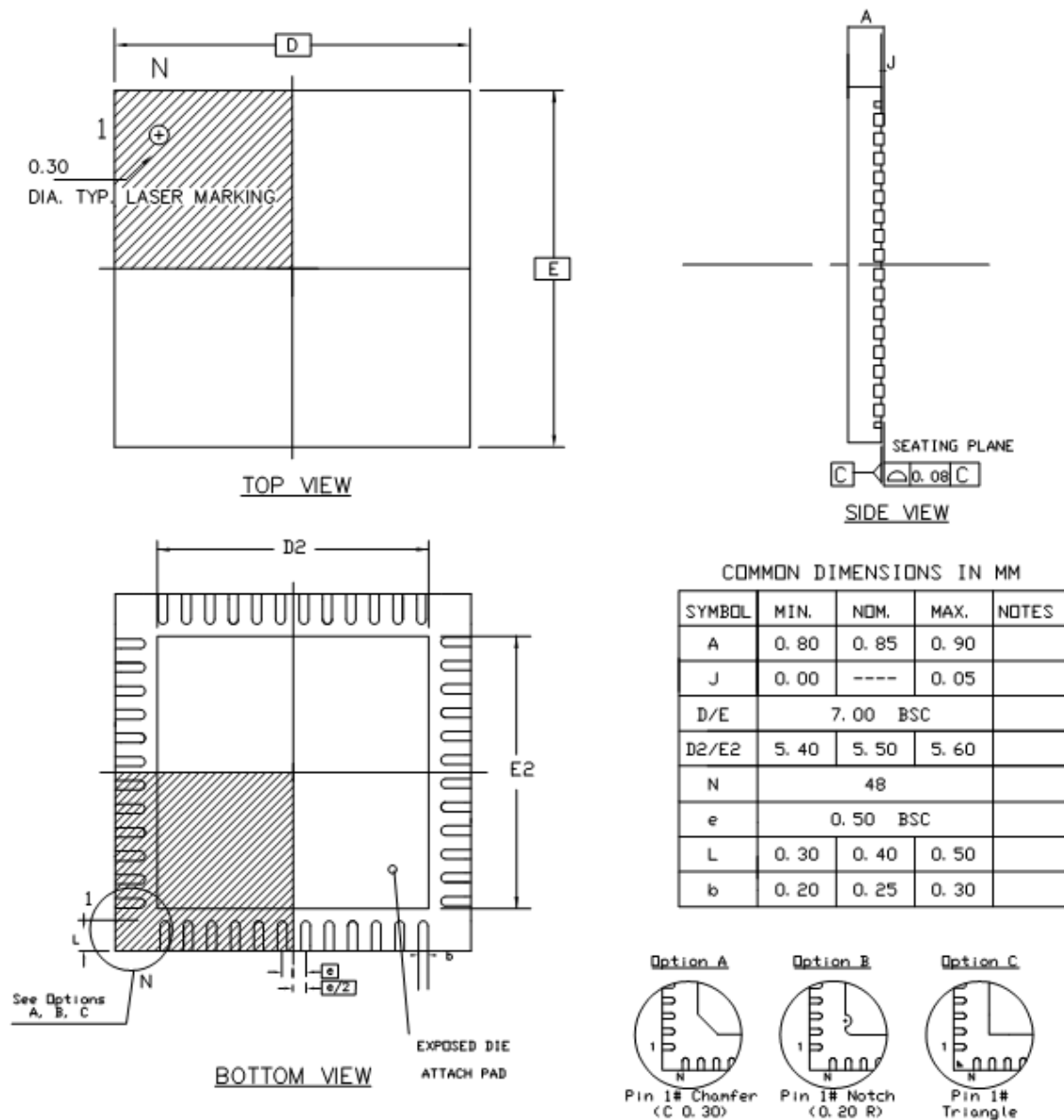

Note: The exposed pad is not connected to anything internally, but should be soldered to ground to increase board level reliability.

Table 8-5. Device and Package Maximum Weight

140	mg
-----	----

Table 8-6. Package Characteristics

Moisture Sensitivity Level	MSL3
----------------------------	------

Table 8-7. Package Reference

JEDEC Drawing Reference	M0-220
JESD97 Classification	E3

Figure 8-3. TLLGA-48 Package Drawing

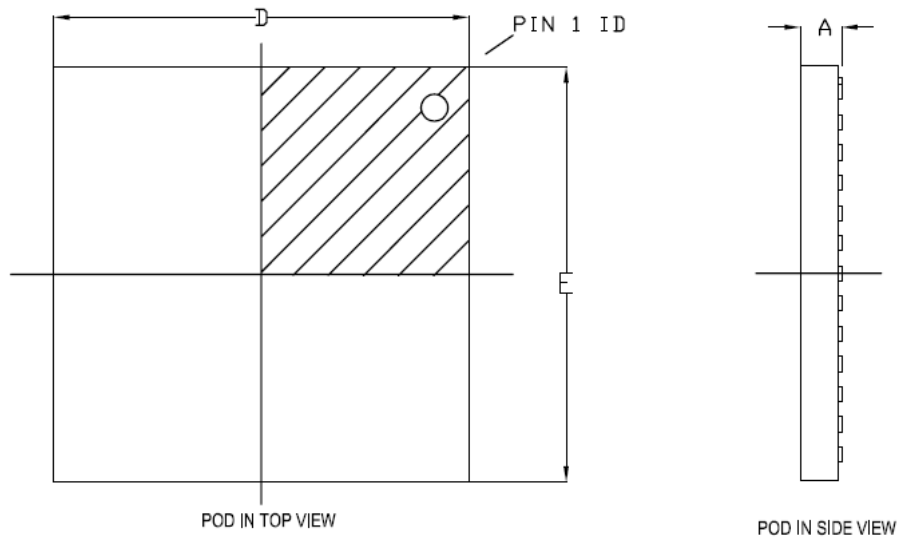

DRAWINGS NOT SCALED

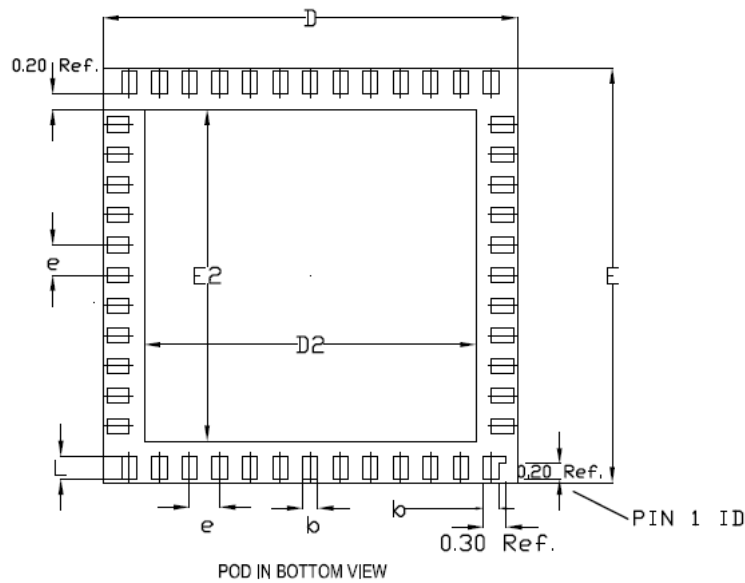

COMMON DIMENSIONS IN MM

SYMBOL	MIN.	NOM.	MAX.	NOTES
A	0.50	0.55	0.60	
J	----	----	----	
D/E	5.40	5.50	5.60	
D2/E2	4.30	4.40	4.50	
N	48			
e	0.40 BSC			
L	0.20	0.30	0.40	
b	0.15	0.20	0.25	

NOT RECOMMENDED TO MOUNT ON ANY FLEX OR FILM PCB OR MCM DEVICE WHICH REQUIRES SECOND MOLD ABOVE THIS PACKAGE

Table 8-8. Device and Package Maximum Weight

39.3	mg
------	----

Table 8-9. Package Characteristics

Moisture Sensitivity Level	MSL3
----------------------------	------

Table 8-10. Package Reference

JEDEC Drawing Reference	N/A
JESD97 Classification	E4

Figure 8-4. TQFP-64 Package Drawing

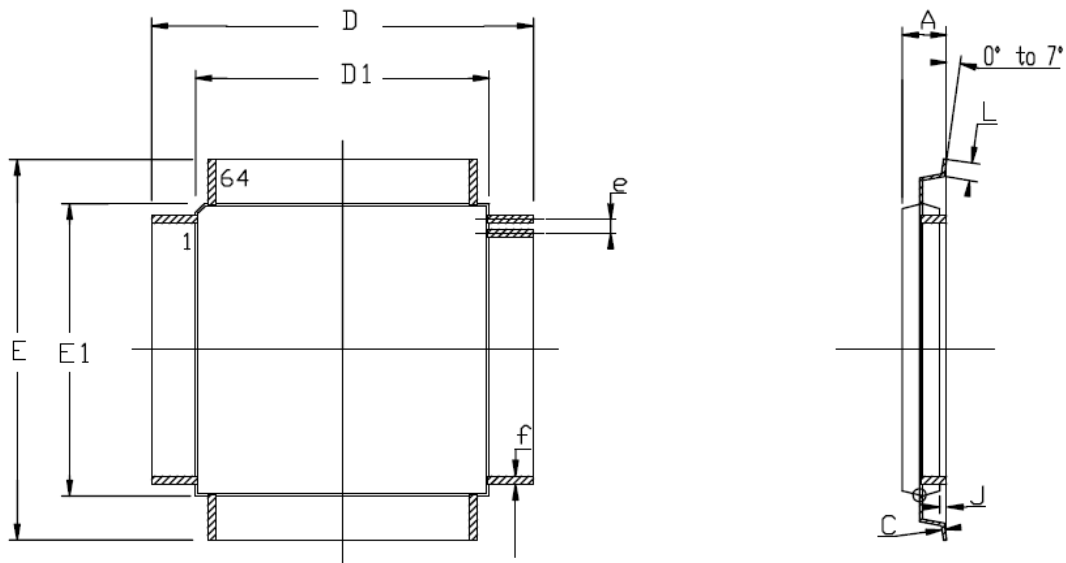

COMMON DIMENSIONS IN MM

SYMBOL	Min	Max	NOTES
A	----	1.20	
A1	0.95	1.05	
C	0.09	0.20	
D	12.00 BSC		
D1	10.00 BSC		
E	12.00 BSC		
E1	10.00 BSC		
J	0.05	0.15	
L	0.45	0.75	
e	0.50 BSC		
f	0.17	0.27	

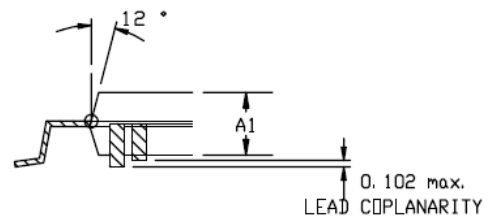

Table 8-11. Device and Package Maximum Weight

300	mg
-----	----

Table 8-12. Package Characteristics

Moisture Sensitivity Level	MSL3
----------------------------	------

Table 8-13. Package Reference

JEDEC Drawing Reference	MS-026
JESD97 Classification	E3

Figure 8-5. QFN-64 Package Drawing

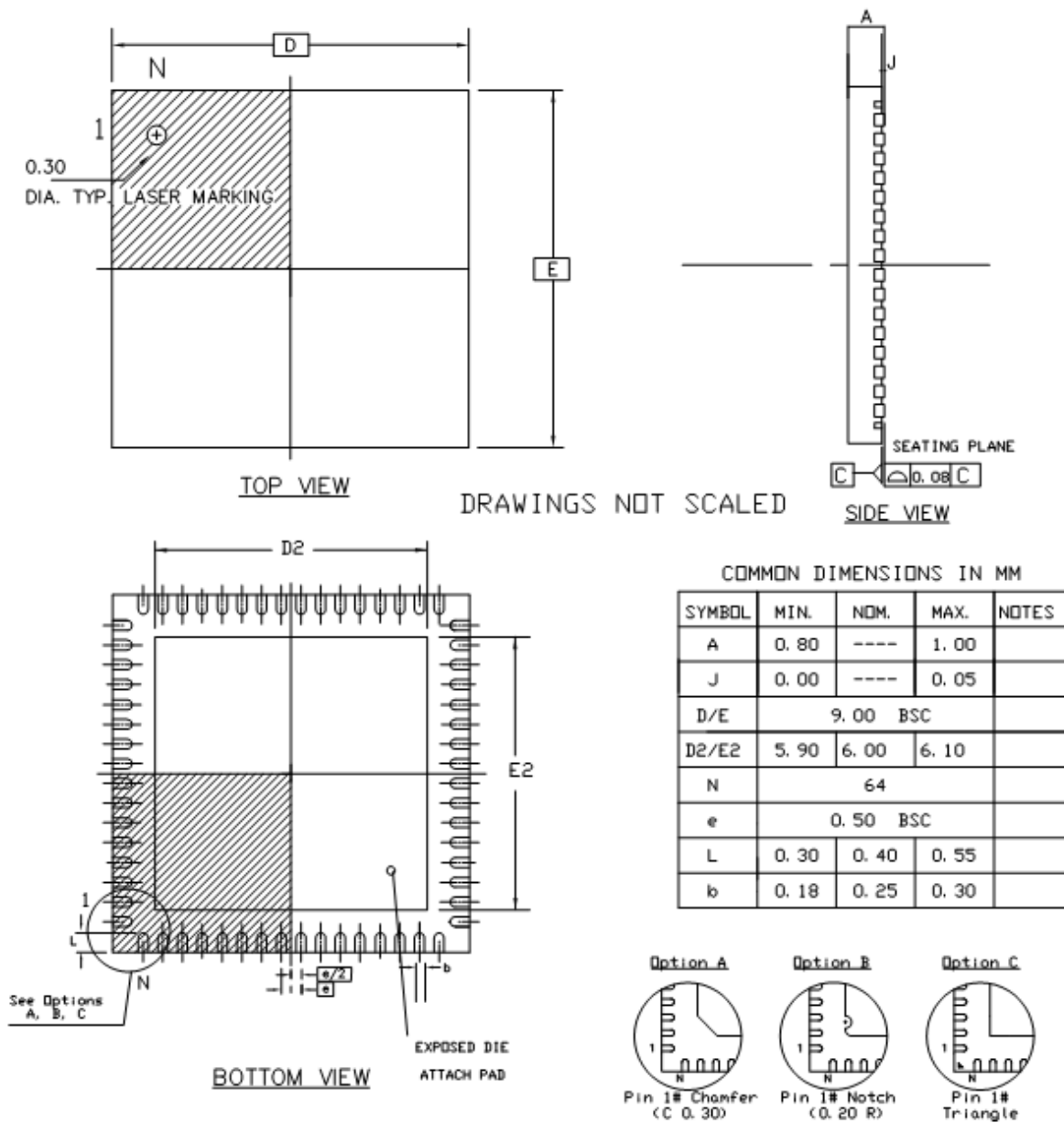

Note: The exposed pad is not connected to anything internally, but should be soldered to ground to increase board level reliability.

Table 8-14. Device and Package Maximum Weight

200	mg
-----	----

Table 8-15. Package Characteristics

Moisture Sensitivity Level	MSL3
----------------------------	------

Table 8-16. Package Reference

JEDEC Drawing Reference	M0-220
JESD97 Classification	E3

8.3 Soldering Profile

Table 8-17 gives the recommended soldering profile from J-STD-20.

Table 8-17. Soldering Profile

Profile Feature	Green Package
Average Ramp-up Rate (217°C to Peak)	3°C/s max
Preheat Temperature 175°C ±25°C	150-200°C
Time Maintained Above 217°C	60-150 s
Time within 5°C of Actual Peak Temperature	30 s
Peak Temperature Range	260°C
Ramp-down Rate	6°C/s max
Time 25°C to Peak Temperature	8 minutes max

A maximum of three reflow passes is allowed per component.

9. Ordering Information

Table 9-1. Ordering Information

Device	Ordering Code	Carrier Type	Package	Package Type	Temperature Operating Range
ATUC256L3U	ATUC256L3U-AUTES	ES	TQFP 64	JESD97 Classification E3	N/A
	ATUC256L3U-AUT	Tray			Industrial (-40°C to 85°C)
	ATUC256L3U-AUR	Tape & Reel			
	ATUC256L3U-Z3UTES	ES	QFN 64		N/A
	ATUC256L3U-Z3UT	Tray			Industrial (-40°C to 85°C)
	ATUC256L3U-Z3UR	Tape & Reel			
ATUC128L3U	ATUC128L3U-AUT	Tray	TQFP 64	JESD97 Classification E3	Industrial (-40°C to 85°C)
	ATUC128L3U-AUR	Tape & Reel			
	ATUC128L3U-Z3UT	Tray	QFN 64		
	ATUC128L3U-Z3UR	Tape & Reel			
ATUC64L3U	ATUC64L3U-AUT	Tray	TQFP 64	JESD97 Classification E3	Industrial (-40°C to 85°C)
	ATUC64L3U-AUR	Tape & Reel			
	ATUC64L3U-Z3UT	Tray	QFN 64		
	ATUC64L3U-Z3UR	Tape & Reel			

Table 9-1. Ordering Information

Device	Ordering Code	Carrier Type	Package	Package Type	Temperature Operating Range	
ATUC256L4U	ATUC256L4U-AUTES	ES	TQFP 48	JESD97 Classification E3	N/A	
	ATUC256L4U-AUT	Tray			Industrial (-40°C to 85°C)	
	ATUC256L4U-AUR	Tape & Reel				
	ATUC256L4U-ZAUTES	ES	QFN 48		N/A	
	ATUC256L4U-ZAUT	Tray			Industrial (-40°C to 85°C)	
	ATUC256L4U-ZAUR	Tape & Reel				
	ATUC256L4U-D3HES	ES	TLLGA 48	JESD97 Classification E4	N/A	
	ATUC256L4U-D3HT	Tray				
	ATUC256L4U-D3HR	Tape & Reel				
ATUC128L4U	ATUC128L4U-AUT	Tray	TQFP 48	JESD97 Classification E3	Industrial (-40°C to 85°C)	
	ATUC128L4U-AUR	Tape & Reel				
	ATUC128L4U-ZAUT	Tray	QFN 48			
	ATUC128L4U-ZAUR	Tape & Reel				
	ATUC128L4U-D3HT	Tray	TLLGA 48	JESD97 Classification E4		
	ATUC128L4U-D3HR	Tape & Reel				
ATUC64L4U	ATUC64L4U-AUT	Tray	TQFP 48	JESD97 Classification E3	Industrial (-40°C to 85°C)	
	ATUC64L4U-AUR	Tape & Reel				
	ATUC64L4U-ZAUT	Tray	QFN 48			
	ATUC64L4U-ZAUR	Tape & Reel				
	ATUC64L4U-D3HT	Tray	TLLGA 48	JESD97 Classification E4		
	ATUC64L4U-D3HR	Tape & Reel				

10. Errata

10.1 Rev. C

10.1.1 SCIF

1. The RC32K output on PA20 is not always permanently disabled

The RC32K output on PA20 may sometimes re-appear.

Fix/Workaround

Before using RC32K for other purposes, the following procedure has to be followed in order to properly disable it:

- Run the CPU on RCSYS
- Disable the output to PA20 by writing a zero to PM.PPCR.RC32OUT
- Enable RC32K by writing a one to SCIF.RC32KCR.EN, and wait for this bit to be read as one
- Disable RC32K by writing a zero to SCIF.RC32KCR.EN, and wait for this bit to be read as zero.

2. PLLCOUNT value larger than zero can cause PLEN glitch

Initializing the PLLCOUNT with a value greater than zero creates a glitch on the PLEN signal during asynchronous wake up.

Fix/Workaround

The lock-masking mechanism for the PLL should not be used.

The PLLCOUNT field of the PLL Control Register should always be written to zero.

3. Writing 0x5A5A5A5A to the SCIF memory range will enable the SCIF UNLOCK feature

The SCIF UNLOCK feature will be enabled if the value 0x5A5A5A5A is written to any location in the SCIF memory range.

Fix/Workaround

None.

10.1.2 SPI

1. SPI data transfer hangs with CSR0.CSAAT==1 and MR.MODFDIS==0

When CSR0.CSAAT==1 and mode fault detection is enabled (MR.MODFDIS==0), the SPI module will not start a data transfer.

Fix/Workaround

Disable mode fault detection by writing a one to MR.MODFDIS.

2. Disabling SPI has no effect on the SR.TDRE bit

Disabling SPI has no effect on the SR.TDRE bit whereas the write data command is filtered when SPI is disabled. Writing to TDR when SPI is disabled will not clear SR.TDRE. If SPI is disabled during a PDCA transfer, the PDCA will continue to write data to TDR until its buffer is empty, and this data will be lost.

Fix/Workaround

Disable the PDCA, add two NOPs, and disable the SPI. To continue the transfer, enable the SPI and PDCA.

3. SPI disable does not work in SLAVE mode

SPI disable does not work in SLAVE mode.

Fix/Workaround

Read the last received data, then perform a software reset by writing a one to the Software Reset bit in the Control Register (CR.SWRST).

4. **SPI bad serial clock generation on 2nd chip_select when SCBR=1, CPOL=1, and NCPHA=0**
 When multiple chip selects (CS) are in use, if one of the baudrates equal 1 while one (CSRn.SCBR=1) of the others do not equal 1, and CSRn.CPOL=1 and CSRn.NCPHA=0, then an additional pulse will be generated on SCK.
Fix/Workaround
 When multiple CS are in use, if one of the baudrates equals 1, the others must also equal 1 if CSRn.CPOL=1 and CSRn.NCPHA=0.

5. **SPI mode fault detection enable causes incorrect behavior**
 When mode fault detection is enabled (MR.MODFDIS==0), the SPI module may not operate properly.
Fix/Workaround
 Always disable mode fault detection before using the SPI by writing a one to MR.MODFDIS.

6. **SPI RDR.PCS is not correct**
 The PCS (Peripheral Chip Select) field in the SPI RDR (Receive Data Register) does not correctly indicate the value on the NPCS pins at the end of a transfer.
Fix/Workaround
 Do not use the PCS field of the SPI RDR.

10.1.3 TWI

1. **SMBALERT bit may be set after reset**
 The SMBus Alert (SMBALERT) bit in the Status Register (SR) might be erroneously set after system reset.
Fix/Workaround
 After system reset, clear the SR.SMBALERT bit before commencing any TWI transfer.

2. **Clearing the NAK bit before the BTF bit is set locks up the TWI bus**
 When the TWIS is in transmit mode, clearing the NAK Received (NAK) bit of the Status Register (SR) before the end of the Acknowledge/Not Acknowledge cycle will cause the TWIS to attempt to continue transmitting data, thus locking up the bus.
Fix/Workaround
 Clear SR.NAK only after the Byte Transfer Finished (BTF) bit of the same register has been set.

10.1.4 TC

1. **Channel chaining skips first pulse for upper channel**
 When chaining two channels using the Block Mode Register, the first pulse of the clock between the channels is skipped.
Fix/Workaround
 Configure the lower channel with RA = 0x1 and RC = 0x2 to produce a dummy clock cycle for the upper channel. After the dummy cycle has been generated, indicated by the SR.CPCS bit, reconfigure the RA and RC registers for the lower channel with the real values.

10.1.5 CAT

1. **CAT QMatrix sense capacitors discharged prematurely**
 At the end of a QMatrix burst charging sequence that uses different burst count values for different Y lines, the Y lines may be incorrectly grounded for up to n-1 periods of the periph-

eral bus clock, where n is the ratio of the PB clock frequency to the GCLK_CAT frequency. This results in premature loss of charge from the sense capacitors and thus increased variability of the acquired count values.

Fix/Workaround

Enable the 1kOhm drive resistors on all implemented QMatrix Y lines (CSA 1, 3, 5, 7, 9, 11, 13, and/or 15) by writing ones to the corresponding odd bits of the CSARES register.

2. Autonomous CAT acquisition must be longer than AST source clock period

When using the AST to trigger CAT autonomous touch acquisition in sleep modes where the CAT bus clock is turned off, the CAT will start several acquisitions if the period of the AST source clock is larger than one CAT acquisition. One AST clock period after the AST trigger, the CAT clock will automatically stop and the CAT acquisition can be stopped prematurely, ruining the result.

Fix/Workaround

Always ensure that the ATCFG1.max field is set so that the duration of the autonomous touch acquisition is greater than one clock period of the AST source clock.

10.1.6 aWire

1. aWire MEMORY_SPEED_REQUEST command does not return correct CV

The aWire MEMORY_SPEED_REQUEST command does not return a CV corresponding to the formula in the aWire Debug Interface chapter.

Fix/Workaround

Issue a dummy read to address 0x10000000 before issuing the MEMORY_SPEED_REQUEST command and use this formula instead:

$$f_{sab} = \frac{7f_{aw}}{CV-3}$$

10.2 Rev. B

10.2.1 SCIF

1. The RC32K output on PA20 is not always permanently disabled

The RC32K output on PA20 may sometimes re-appear.

Fix/Workaround

Before using RC32K for other purposes, the following procedure has to be followed in order to properly disable it:

- Run the CPU on RCSYS
- Disable the output to PA20 by writing a zero to PM.PPCR.RC32OUT
- Enable RC32K by writing a one to SCIF.RC32KCR.EN, and wait for this bit to be read as one
- Disable RC32K by writing a zero to SCIF.RC32KCR.EN, and wait for this bit to be read as zero.

2. PLLCOUNT value larger than zero can cause PLEN glitch

Initializing the PLLCOUNT with a value greater than zero creates a glitch on the PLEN signal during asynchronous wake up.

Fix/Workaround

The lock-masking mechanism for the PLL should not be used.

The PLLCOUNT field of the PLL Control Register should always be written to zero.

3. Writing 0x5A5A5A5A to the SCIF memory range will enable the SCIF UNLOCK feature

The SCIF UNLOCK feature will be enabled if the value 0x5A5A5A5A is written to any location in the SCIF memory range.

Fix/Workaround

None.

10.2.2 WDT

1. WDT Control Register does not have synchronization feedback

When writing to the Timeout Prescale Select (PSEL), Time Ban Prescale Select (TBAN), Enable (EN), or WDT Mode (MODE) fields of the WDT Control Register (CTRL), a synchronizer is started to propagate the values to the WDT clock domain. This synchronization takes a finite amount of time, but only the status of the synchronization of the EN bit is reflected back to the user. Writing to the synchronized fields during synchronization can lead to undefined behavior.

Fix/Workaround

-When writing to the affected fields, the user must ensure a wait corresponding to 2 clock cycles of both the WDT peripheral bus clock and the selected WDT clock source.

-When doing writes that changes the EN bit, the EN bit can be read back until it reflects the written value.

10.2.3 SPI

1. SPI data transfer hangs with CSR0.CSAAT==1 and MR.MODFDIS==0

When CSR0.CSAAT==1 and mode fault detection is enabled (MR.MODFDIS==0), the SPI module will not start a data transfer.

Fix/Workaround

Disable mode fault detection by writing a one to MR.MODFDIS.

2. Disabling SPI has no effect on the SR.TDRE bit

Disabling SPI has no effect on the SR.TDRE bit whereas the write data command is filtered when SPI is disabled. Writing to TDR when SPI is disabled will not clear SR.TDRE. If SPI is disabled during a PDCA transfer, the PDCA will continue to write data to TDR until its buffer is empty, and this data will be lost.

Fix/Workaround

Disable the PDCA, add two NOPs, and disable the SPI. To continue the transfer, enable the SPI and PDCA.

3. SPI disable does not work in SLAVE mode

SPI disable does not work in SLAVE mode.

Fix/Workaround

Read the last received data, then perform a software reset by writing a one to the Software Reset bit in the Control Register (CR.SWRST).

4. SPI bad serial clock generation on 2nd chip_select when SCBR=1, CPOL=1, and NCPHA=0

When multiple chip selects (CS) are in use, if one of the baudrates equal 1 while one (CSRn.SCBR=1) of the others do not equal 1, and CSRn.CPOL=1 and CSRn.NCPHA=0, then an additional pulse will be generated on SCK.

Fix/Workaround

When multiple CS are in use, if one of the baudrates equals 1, the others must also equal 1 if CSRn.CPOL=1 and CSRn.NCPHA=0.

5. SPI mode fault detection enable causes incorrect behavior

When mode fault detection is enabled (MR.MODFDIS==0), the SPI module may not operate

properly.

Fix/Workaround

Always disable mode fault detection before using the SPI by writing a one to MR.MODFDIS.

6. SPI RDR.PCS is not correct

The PCS (Peripheral Chip Select) field in the SPI RDR (Receive Data Register) does not correctly indicate the value on the NPCS pins at the end of a transfer.

Fix/Workaround

Do not use the PCS field of the SPI RDR.

10.2.4 TWI

1. TWIS may not wake the device from sleep mode

If the CPU is put to a sleep mode (except Idle and Frozen) directly after a TWI Start condition, the CPU may not wake upon a TWIS address match. The request is NACKed.

Fix/Workaround

When using the TWI address match to wake the device from sleep, do not switch to sleep modes deeper than Frozen. Another solution is to enable asynchronous EIC wake on the TWIS clock (TWCK) or TWIS data (TWD) pins, in order to wake the system up on bus events.

2. SMBALERT bit may be set after reset

The SMBus Alert (SMBALERT) bit in the Status Register (SR) might be erroneously set after system reset.

Fix/Workaround

After system reset, clear the SR.SMBALERT bit before commencing any TWI transfer.

3. Clearing the NAK bit before the BTF bit is set locks up the TWI bus

When the TWIS is in transmit mode, clearing the NAK Received (NAK) bit of the Status Register (SR) before the end of the Acknowledge/Not Acknowledge cycle will cause the TWIS to attempt to continue transmitting data, thus locking up the bus.

Fix/Workaround

Clear SR.NAK only after the Byte Transfer Finished (BTF) bit of the same register has been set.

10.2.5 PWMA

1. The SR.READY bit cannot be cleared by writing to SCR.READY

The Ready bit in the Status Register will not be cleared when writing a one to the corresponding bit in the Status Clear register. The Ready bit will be cleared when the Busy bit is set.

Fix/Workaround

Disable the Ready interrupt in the interrupt handler when receiving the interrupt. When an operation that triggers the Busy/Ready bit is started, wait until the ready bit is low in the Status Register before enabling the interrupt.

10.2.6 TC

1. Channel chaining skips first pulse for upper channel

When chaining two channels using the Block Mode Register, the first pulse of the clock between the channels is skipped.

Fix/Workaround

Configure the lower channel with RA = 0x1 and RC = 0x2 to produce a dummy clock cycle for the upper channel. After the dummy cycle has been generated, indicated by the SR.CPCS bit, reconfigure the RA and RC registers for the lower channel with the real values.

10.2.7 CAT

1. CAT QMatrix sense capacitors discharged prematurely

At the end of a QMatrix burst charging sequence that uses different burst count values for different Y lines, the Y lines may be incorrectly grounded for up to n-1 periods of the peripheral bus clock, where n is the ratio of the PB clock frequency to the GCLK_CAT frequency. This results in premature loss of charge from the sense capacitors and thus increased variability of the acquired count values.

Fix/Workaround

Enable the 1kOhm drive resistors on all implemented QMatrix Y lines (CSA 1, 3, 5, 7, 9, 11, 13, and/or 15) by writing ones to the corresponding odd bits of the CSARES register.

2. Autonomous CAT acquisition must be longer than AST source clock period

When using the AST to trigger CAT autonomous touch acquisition in sleep modes where the CAT bus clock is turned off, the CAT will start several acquisitions if the period of the AST source clock is larger than one CAT acquisition. One AST clock period after the AST trigger, the CAT clock will automatically stop and the CAT acquisition can be stopped prematurely, ruining the result.

Fix/Workaround

Always ensure that the ATCFG1.max field is set so that the duration of the autonomous touch acquisition is greater than one clock period of the AST source clock.

3. CAT consumes unnecessary power when disabled or when autonomous touch not used

A CAT prescaler controlled by the ATCFG0.DIV field will be active even when the CAT module is disabled or when the autonomous touch feature is not used, thereby causing unnecessary power consumption.

Fix/Workaround

If the CAT module is not used, disable the CLK_CAT clock in the PM module. If the CAT module is used but the autonomous touch feature is not used, the power consumption of the CAT module may be reduced by writing 0xFFFF to the ATCFG0.DIV field.

10.2.8 aWire

1. aWire MEMORY_SPEED_REQUEST command does not return correct CV

The aWire MEMORY_SPEED_REQUEST command does not return a CV corresponding to the formula in the aWire Debug Interface chapter.

Fix/Workaround

Issue a dummy read to address 0x10000000 before issuing the MEMORY_SPEED_REQUEST command and use this formula instead:

$$f_{sab} = \frac{7f_{aw}}{CV-3}$$

10.3 Rev. A

10.3.1 Device

- JTAGID is wrong**
 The JTAGID is 0x021DF03F.
Fix/Workaround
 None.

10.3.2 FLASHCDW

- General-purpose fuse programming does not work**
 The general-purpose fuses cannot be programmed and are stuck at 1. Please refer to the Fuse Settings chapter in the FLASHCDW for more information about what functions are affected.
Fix/Workaround
 None.
- Set Security Bit command does not work**
 The Set Security Bit (SSB) command of the FLASHCDW does not work. The device cannot be locked from external JTAG, aWire, or other debug accesses.
Fix/Workaround
 None.
- Flash programming time is longer than specified**
 The flash programming time is now:

Table 10-1. Flash Characteristics

Symbol	Parameter	Conditions	Min	Typ	Max	Unit
T _{FPP}	Page programming time	f _{CLK_HSB} = 50MHz		7.5		ms
T _{FPE}	Page erase time			7.5		
T _{FFP}	Fuse programming time			1		
T _{FEA}	Full chip erase time (EA)			9		
T _{FCE}	JTAG chip erase time (CHIP_ERASE)	f _{CLK_HSB} = 115kHz		250		

Fix/Workaround

None.

10.3.3 Power Manager

- Clock Failure Detector (CFD) can be issued while turning off the CFD**
 While turning off the CFD, the CFD bit in the Status Register (SR) can be set. This will change the main clock source to RCSYS.
Fix/Workaround
 Solution 1: Enable CFD interrupt. If CFD interrupt is issues after turning off the CFD, switch back to original main clock source.
 Solution 2: Only turn off the CFD while running the main clock on RCSYS.
- Sleepwalking in idle and frozen sleep mode will mask all other PB clocks**

If the CPU is in idle or frozen sleep mode and a module is in a state that triggers sleep walking, all PB clocks will be masked except the PB clock to the sleepwalking module.

Fix/Workaround

Mask all clock requests in the PM.PPCR register before going into idle or frozen mode.

3. Unused PB clocks are running

Three unused PBA clocks are enabled by default and will cause increased active power consumption.

Fix/Workaround

Disable the clocks by writing zeroes to bits [27:25] in the PBA clock mask register.

10.3.4 SCIF

1. The RC32K output on PA20 is not always permanently disabled

The RC32K output on PA20 may sometimes re-appear.

Fix/Workaround

Before using RC32K for other purposes, the following procedure has to be followed in order to properly disable it:

- Run the CPU on RCSYS
- Disable the output to PA20 by writing a zero to PM.PPCR.RC32OUT
- Enable RC32K by writing a one to SCIF.RC32KCR.EN, and wait for this bit to be read as one
- Disable RC32K by writing a zero to SCIF.RC32KCR.EN, and wait for this bit to be read as zero.

2. PLL lock might not clear after disable

Under certain circumstances, the lock signal from the Phase Locked Loop (PLL) oscillator may not go back to zero after the PLL oscillator has been disabled. This can cause the propagation of clock signals with the wrong frequency to parts of the system that use the PLL clock.

Fix/Workaround

PLL must be turned off before entering STOP, DEEPSTOP or STATIC sleep modes. If PLL has been turned off, a delay of 30us must be observed after the PLL has been enabled again before the SCIF.PLL0LOCK bit can be used as a valid indication that the PLL is locked.

3. PLLCOUNT value larger than zero can cause PLEN glitch

Initializing the PLLCOUNT with a value greater than zero creates a glitch on the PLEN signal during asynchronous wake up.

Fix/Workaround

The lock-masking mechanism for the PLL should not be used.
The PLLCOUNT field of the PLL Control Register should always be written to zero.

4. RCSYS is not calibrated

The RCSYS is not calibrated and will run faster than 115.2kHz. Frequencies around 150kHz can be expected.

Fix/Workaround

If a known clock source is available the RCSYS can be runtime calibrated by using the frequency meter (FREQM) and tuning the RCSYS by writing to the RCCR register in SCIF.

5. Writing 0x5A5A5A5A to the SCIF memory range will enable the SCIF UNLOCK feature

The SCIF UNLOCK feature will be enabled if the value 0x5A5A5A5A is written to any location in the SCIF memory range.

Fix/Workaround

None.

10.3.5 WDT

1. Clearing the Watchdog Timer (WDT) counter in second half of timeout period will issue a Watchdog reset

If the WDT counter is cleared in the second half of the timeout period, the WDT will immediately issue a Watchdog reset.

Fix/Workaround

Use twice as long timeout period as needed and clear the WDT counter within the first half of the timeout period. If the WDT counter is cleared after the first half of the timeout period, you will get a Watchdog reset immediately. If the WDT counter is not cleared at all, the time before the reset will be twice as long as needed.

2. WDT Control Register does not have synchronization feedback

When writing to the Timeout Prescale Select (PSEL), Time Ban Prescale Select (TBAN), Enable (EN), or WDT Mode (MODE) fields of the WDT Control Register (CTRL), a synchronizer is started to propagate the values to the WDT clock domain. This synchronization takes a finite amount of time, but only the status of the synchronization of the EN bit is reflected back to the user. Writing to the synchronized fields during synchronization can lead to undefined behavior.

Fix/Workaround

-When writing to the affected fields, the user must ensure a wait corresponding to 2 clock cycles of both the WDT peripheral bus clock and the selected WDT clock source.

-When doing writes that changes the EN bit, the EN bit can be read back until it reflects the written value.

10.3.6 GPIO

1. Clearing Interrupt flags can mask other interrupts

When clearing interrupt flags in a GPIO port, interrupts on other pins of that port, happening in the same clock cycle will not be registered.

Fix/Workaround

Read the PVR register of the port before and after clearing the interrupt to see if any pin change has happened while clearing the interrupt. If any change occurred in the PVR between the reads, they must be treated as an interrupt.

10.3.7 SPI

1. SPI data transfer hangs with CSR0.CSAAT==1 and MR.MODFDIS==0

When CSR0.CSAAT==1 and mode fault detection is enabled (MR.MODFDIS==0), the SPI module will not start a data transfer.

Fix/Workaround

Disable mode fault detection by writing a one to MR.MODFDIS.

2. Disabling SPI has no effect on the SR.TDRE bit

Disabling SPI has no effect on the SR.TDRE bit whereas the write data command is filtered when SPI is disabled. Writing to TDR when SPI is disabled will not clear SR.TDRE. If SPI is disabled during a PDCA transfer, the PDCA will continue to write data to TDR until its buffer is empty, and this data will be lost.

Fix/Workaround

Disable the PDCA, add two NOPs, and disable the SPI. To continue the transfer, enable the SPI and PDCA.

3. SPI disable does not work in SLAVE mode

SPI disable does not work in SLAVE mode.

Fix/Workaround

Read the last received data, then perform a software reset by writing a one to the Software Reset bit in the Control Register (CR.SWRST).

4. SPI bad serial clock generation on 2nd chip_select when SCBR=1, CPOL=1, and NCPHA=0

When multiple chip selects (CS) are in use, if one of the baudrates equal 1 while one (CSRn.SCBR=1) of the others do not equal 1, and CSRn.CPOL=1 and CSRn.NCPHA=0, then an additional pulse will be generated on SCK.

Fix/Workaround

When multiple CS are in use, if one of the baudrates equals 1, the others must also equal 1 if CSRn.CPOL=1 and CSRn.NCPHA=0.

5. SPI mode fault detection enable causes incorrect behavior

When mode fault detection is enabled (MR.MODFDIS==0), the SPI module may not operate properly.

Fix/Workaround

Always disable mode fault detection before using the SPI by writing a one to MR.MODFDIS.

6. SPI RDR.PCS is not correct

The PCS (Peripheral Chip Select) field in the SPI RDR (Receive Data Register) does not correctly indicate the value on the NPCS pins at the end of a transfer.

Fix/Workaround

Do not use the PCS field of the SPI RDR.

10.3.8 TWI

1. TWIS may not wake the device from sleep mode

If the CPU is put to a sleep mode (except Idle and Frozen) directly after a TWI Start condition, the CPU may not wake upon a TWIS address match. The request is NACKed.

Fix/Workaround

When using the TWI address match to wake the device from sleep, do not switch to sleep modes deeper than Frozen. Another solution is to enable asynchronous EIC wake on the TWIS clock (TWCK) or TWIS data (TWD) pins, in order to wake the system up on bus events.

2. SMBALERT bit may be set after reset

The SMBus Alert (SMBALERT) bit in the Status Register (SR) might be erroneously set after system reset.

Fix/Workaround

After system reset, clear the SR.SMBALERT bit before commencing any TWI transfer.

3. Clearing the NAK bit before the BTF bit is set locks up the TWI bus

When the TWIS is in transmit mode, clearing the NAK Received (NAK) bit of the Status Register (SR) before the end of the Acknowledge/Not Acknowledge cycle will cause the TWIS to attempt to continue transmitting data, thus locking up the bus.

Fix/Workaround

Clear SR.NAK only after the Byte Transfer Finished (BTF) bit of the same register has been set.

4. TWIS stretch on Address match error



When the TWIS stretches TWCK due to a slave address match, it also holds TWD low for the same duration if it is to be receiving data. When TWIS releases TWCK, it releases TWD at the same time. This can cause a TWI timing violation.

Fix/Workaround

None.

5. TWIM TWALM polarity is wrong

The TWALM signal in the TWIM is active high instead of active low.

Fix/Workaround

Use an external inverter to invert the signal going into the TWIM. When using both TWIM and TWIS on the same pins, the TWALM cannot be used.

10.3.9 PWMA

1. The SR.READY bit cannot be cleared by writing to SCR.READY

The Ready bit in the Status Register will not be cleared when writing a one to the corresponding bit in the Status Clear register. The Ready bit will be cleared when the Busy bit is set.

Fix/Workaround

Disable the Ready interrupt in the interrupt handler when receiving the interrupt. When an operation that triggers the Busy/Ready bit is started, wait until the ready bit is low in the Status Register before enabling the interrupt.

10.3.10 TC

1. Channel chaining skips first pulse for upper channel

When chaining two channels using the Block Mode Register, the first pulse of the clock between the channels is skipped.

Fix/Workaround

Configure the lower channel with RA = 0x1 and RC = 0x2 to produce a dummy clock cycle for the upper channel. After the dummy cycle has been generated, indicated by the SR.CPCS bit, reconfigure the RA and RC registers for the lower channel with the real values.

10.3.11 ADCIFB

1. ADCIFB DMA transfer does not work with divided PBA clock

DMA requests from the ADCIFB will not be performed when the PBA clock is slower than the HSB clock.

Fix/Workaround

Do not use divided PBA clock when the PDCA transfers from the ADCIFB.

10.3.12 CAT

1. CAT QMatrix sense capacitors discharged prematurely

At the end of a QMatrix burst charging sequence that uses different burst count values for different Y lines, the Y lines may be incorrectly grounded for up to n-1 periods of the peripheral bus clock, where n is the ratio of the PB clock frequency to the GCLK_CAT frequency. This results in premature loss of charge from the sense capacitors and thus increased variability of the acquired count values.

Fix/Workaround

Enable the 1kOhm drive resistors on all implemented QMatrix Y lines (CSA 1, 3, 5, 7, 9, 11, 13, and/or 15) by writing ones to the corresponding odd bits of the CSARES register.

2. Autonomous CAT acquisition must be longer than AST source clock period

When using the AST to trigger CAT autonomous touch acquisition in sleep modes where the CAT bus clock is turned off, the CAT will start several acquisitions if the period of the AST source clock is larger than one CAT acquisition. One AST clock period after the AST trigger, the CAT clock will automatically stop and the CAT acquisition can be stopped prematurely, ruining the result.

Fix/Workaround

Always ensure that the ATCFG1.max field is set so that the duration of the autonomous touch acquisition is greater than one clock period of the AST source clock.

3. CAT consumes unnecessary power when disabled or when autonomous touch not used

A CAT prescaler controlled by the ATCFG0.DIV field will be active even when the CAT module is disabled or when the autonomous touch feature is not used, thereby causing unnecessary power consumption.

Fix/Workaround

If the CAT module is not used, disable the CLK_CAT clock in the PM module. If the CAT module is used but the autonomous touch feature is not used, the power consumption of the CAT module may be reduced by writing 0xFFFF to the ATCFG0.DIV field.

4. CAT module does not terminate QTouch burst on detect

The CAT module does not terminate a QTouch burst when the detection voltage is reached on the sense capacitor. This can cause the sense capacitor to be charged more than necessary. Depending on the dielectric absorption characteristics of the capacitor, this can lead to unstable measurements.

Fix/Workaround

Use the minimum possible value for the MAX field in the ATCFG1, TG0CFG1, and TG1CFG1 registers.

10.3.13 aWire

1. aWire MEMORY_SPEED_REQUEST command does not return correct CV

The aWire MEMORY_SPEED_REQUEST command does not return a CV corresponding to the formula in the aWire Debug Interface chapter.

Fix/Workaround

Issue a dummy read to address 0x10000000 before issuing the MEMORY_SPEED_REQUEST command and use this formula instead:

$$f_{sab} = \frac{7f_{aw}}{CV-3}$$

10.3.14 I/O Pins

1. PA05 is not 3.3V tolerant.

PA05 should be grounded on the PCB and left unused if VDDIO is above 1.8V.

Fix/Workaround

None.

2. No pull-up on pins that are not bonded

PB13 to PB27 are not bonded on UC3L0256/128, but has no pull-up and can cause current consumption on VDDIO/VDDIN if left undriven.

Fix/Workaround

Enable pull-ups on PB13 to PB27 by writing 0x0FFFE000 to the PUERS1 register in the GPIO.

3. PA17 has low ESD tolerance

PA17 only tolerates 500V ESD pulses (Human Body Model).

Fix/Workaround

Care must be taken during manufacturing and PCB design.

11. Datasheet Revision History

Please note that the referring page numbers in this section are referred to this document. The referring revision in this section are referring to the document revision.

11.1 Rev. A – 12/2011

1. Initial revision.

Table of Contents

Features 1

1 Description 3

2 Overview 5

 2.1 Block Diagram5

 2.2 Configuration Summary6

3 Package and Pinout 7

 3.1 Package7

 3.2 Peripheral Multiplexing on I/O lines 10

 3.3 Signal Descriptions 15

 3.4 I/O Line Considerations 18

4 Memories 21

 4.1 Embedded Memories21

 4.2 Physical Memory Map21

 4.3 Peripheral Address Map22

 4.4 CPU Local Bus Mapping23

5 Supply and Startup Considerations 25

 5.1 Supply Considerations25

 5.2 Startup Considerations30

6 Programming and Debugging 31

 6.1 Overview31

 6.2 Service Access Bus31

7 Electrical Characteristics 34

 7.1 Absolute Maximum Ratings*34

 7.2 Supply Characteristics34

 7.3 Maximum Clock Frequencies35

 7.4 Power Consumption35

 7.5 I/O Pin Characteristics39

 7.6 Oscillator Characteristics42

 7.7 Flash Characteristics46

 7.8 ABDACB Electrical Characteristics.47

 7.9 Analog Characteristics48

 7.10 Timing Characteristics57

8	<i>Mechanical Characteristics</i>	67
8.1	Thermal Considerations	67
8.2	Package Drawings	68
8.3	Soldering Profile	73
9	<i>Ordering Information</i>	74
10	<i>Errata</i>	76
10.1	Rev. C	76
10.2	Rev. B	78
10.3	Rev. A	82
11	<i>Datasheet Revision History</i>	89
11.1	Rev. A – 12/2011	89
	<i>Table of Contents</i>	<i>i</i>

**Atmel Corporation**

2325 Orchard Parkway
San Jose, CA 95131
USA

Tel: (+1)(408) 441-0311

Fax: (+1)(408) 487-2600

www.atmel.com

Atmel Asia Limited

Unit 1-5 & 16, 19/F
BEA Tower, Millennium City 5
418 Kwun Tong Road
Kwun Tong, Kowloon
HONG KONG

Tel: (+852) 2245-6100

Fax: (+852) 2722-1369

Atmel Munich GmbH

Business Campus
Parkring 4
D-85748 Garching b. Munich
GERMANY

Tel: (+49) 89-31970-0

Fax: (+49) 89-3194621

Atmel Japan

16F, Shin Osaki Kangyo Bldg.
1-6-4 Osaka Shinagawa-ku
Tokyo 104-0032

JAPAN

Tel: (+81) 3-6417-0300

Fax: (+81) 3-6417-0370

© 2011 Atmel Corporation. All rights reserved.

Atmel®, logo and combinations thereof, AVR®, picoPower®, QTouch®, AKS® and others are registered trademarks or trademarks of Atmel Corporation or its subsidiaries. Other terms and product names may be trademarks of others.

Disclaimer: The information in this document is provided in connection with Atmel products. No license, express or implied, by estoppel or otherwise, to any intellectual property right is granted by this document or in connection with the sale of Atmel products. **EXCEPT AS SET FORTH IN THE ATMEL TERMS AND CONDITIONS OF SALES LOCATED ON THE ATMEL WEBSITE, ATMEL ASSUMES NO LIABILITY WHATSOEVER AND DISCLAIMS ANY EXPRESS, IMPLIED OR STATUTORY WARRANTY RELATING TO ITS PRODUCTS INCLUDING, BUT NOT LIMITED TO, THE IMPLIED WARRANTY OF MERCHANTABILITY, FITNESS FOR A PARTICULAR PURPOSE, OR NON-INFRINGEMENT. IN NO EVENT SHALL ATMEL BE LIABLE FOR ANY DIRECT, INDIRECT, CONSEQUENTIAL, PUNITIVE, SPECIAL OR INCIDENTAL DAMAGES (INCLUDING, WITHOUT LIMITATION, DAMAGES FOR LOSS AND PROFITS, BUSINESS INTERRUPTION, OR LOSS OF INFORMATION) ARISING OUT OF THE USE OR INABILITY TO USE THIS DOCUMENT, EVEN IF ATMEL HAS BEEN ADVISED OF THE POSSIBILITY OF SUCH DAMAGES.** Atmel makes no representations or warranties with respect to the accuracy or completeness of the contents of this document and reserves the right to make changes to specifications and product descriptions at any time without notice. Atmel does not make any commitment to update the information contained herein. Unless specifically provided otherwise, Atmel products are not suitable for, and shall not be used in, automotive applications. Atmel products are not intended, authorized, or warranted for use as components in applications intended to support or sustain life.