

THIS DRAWING IS UNCLASSIFIED
 UNLESS INDICATED OTHERWISE
 © 2015 TTI ELECTRONICS CORPORATION ALL RIGHTS RESERVED

REV	DF	FO	DATE	DESCRIPTION	BY	CHK	APP
1	B		REV PER EC 0114-0115-06				

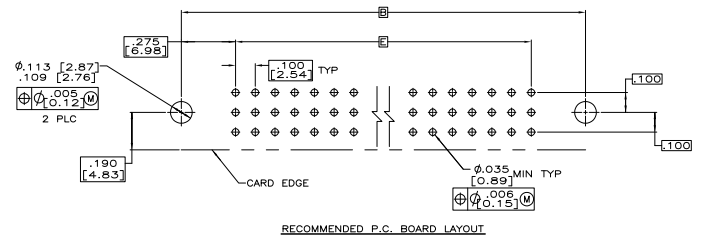
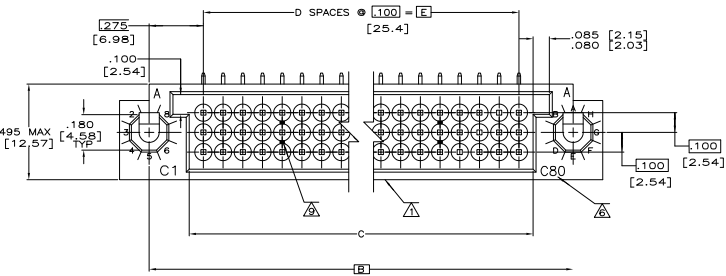
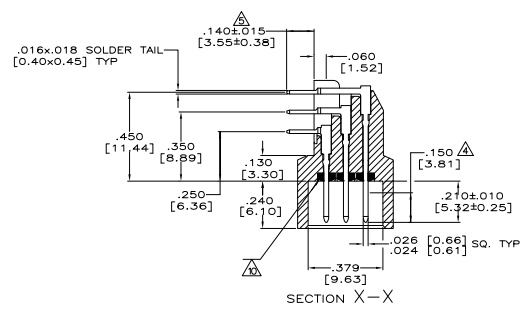
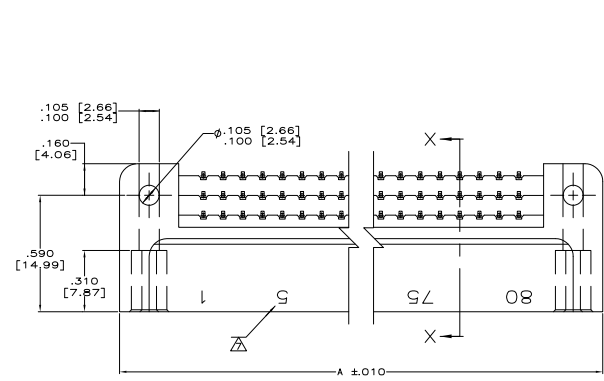

- ▲ MILITARY PART NO., 00779, DATE CODE, PART NO. AND AMP MARKED THIS SIDE.
- ▲ HOUSING MAT'L: POLYPHENYLENE SULFIDE, GST-40F PER MIL-M-24519.
- ▲ CONTACT MAT'L: BRASS PER QQ-B-626.
- ▲ CONTACT FINISH: .000050" [0.00127] GOLD OVER .000050" [0.00127] NICKEL IN CONTACT AREA.
- ▲ CONTACT FINISH: .000100" [0.00254] TIN-LEAD OVER .000050" [0.00127] NICKEL.
- ▲ LETTERS INDICATING OUTSIDE ROWS AND NUMBERS INDICATING END CAVITIES (ROW C ONLY) MARKED THIS SURFACE.
- ▲ NUMBERS INDICATING EVERY FIVE CAVITIES MARKED, BOTH SIDES.
- ▲ MEETS ALL REQUIREMENTS OF MIL-C-55302.
- ▲ LINES INDICATING EVERY FIVE CAVITIES MARKED ON MATING FACE, EXCEPT END CAVITIES, STARTING AT POSN. #1.
- ▲ EPOXY SEALANT TO PREVENT WICKING OF FLUXES AND CONFORMAL COATING INTO THE CONTACT ENGAGEMENT AREA.

M55302/129-16	6,400 [162.56]	64	6,544 [166.21]	6,950 [176.53]	7,250 [184.15]	195	1-446852-0
M55302/129-12	4,400 [111.76]	44	4,544 [115.41]	4,950 [125.75]	5,250 [133.35]	135	446852-9
M55302/129-18	7,900 [200.66]	79	8,044 [204.31]	8,450 [214.63]	8,750 [222.25]	240	446852-8
M55302/129-17	6,900 [175.26]	69	7,044 [178.91]	7,450 [189.23]	7,750 [196.85]	210	446852-7
M55302/129-15	5,900 [149.86]	59	6,044 [153.51]	6,450 [163.83]	6,750 [171.45]	180	446852-6
M55302/129-14	5,400 [137.16]	54	5,544 [140.81]	5,950 [151.13]	6,250 [158.75]	165	446852-5
M55302/129-13	4,900 [124.46]	49	5,044 [128.11]	5,450 [138.43]	5,750 [146.05]	150	446852-4
M55302/129-11	3,900 [99.06]	39	4,044 [102.71]	4,450 [113.03]	4,750 [120.65]	120	446852-3
M55302/129-10	3,400 [86.36]	34	3,544 [90.01]	3,950 [100.33]	4,250 [107.95]	105	446852-2
M55302/129-09	2,900 [73.66]	29	3,044 [77.31]	3,450 [87.63]	3,750 [95.25]	90	446852-1
MILITARY P/N	E	D	C	B	A	POSN.	PART NO.

THIS DRAWING IS A CONTROLLED DOCUMENT. © 2015 TTI ELECTRONICS CORPORATION

DESIGNED BY: J. MILLER
 CHECKED BY: J. MILLER
 DATE: 01/14/15

PROJECT: PIN HEADER ASSY, RIGHT ANGLE, .100

SIZE: A1
 DATE: 01/14/15
 DRAWING NO: 00779
 PART NO: 446852

CUSTOMER DRAWING