

REVISIONS			
LTR	DESCRIPTION	DATE	APPROVED
N/C	INITIAL RELEASE PER ECN# T-20188	6/15/95	M.HIGGY
A	RELEASED PER ECN# T-21270	3/11/97	M.HIGGY

CONTACT, ELECTRICAL CONNECTOR, CONCENTRIC TWINAX, PIN, SHIELDED, SIZE 8, SOLDER TACT® , (FOR MIL-C-38999 SERIES I, III AND IV)

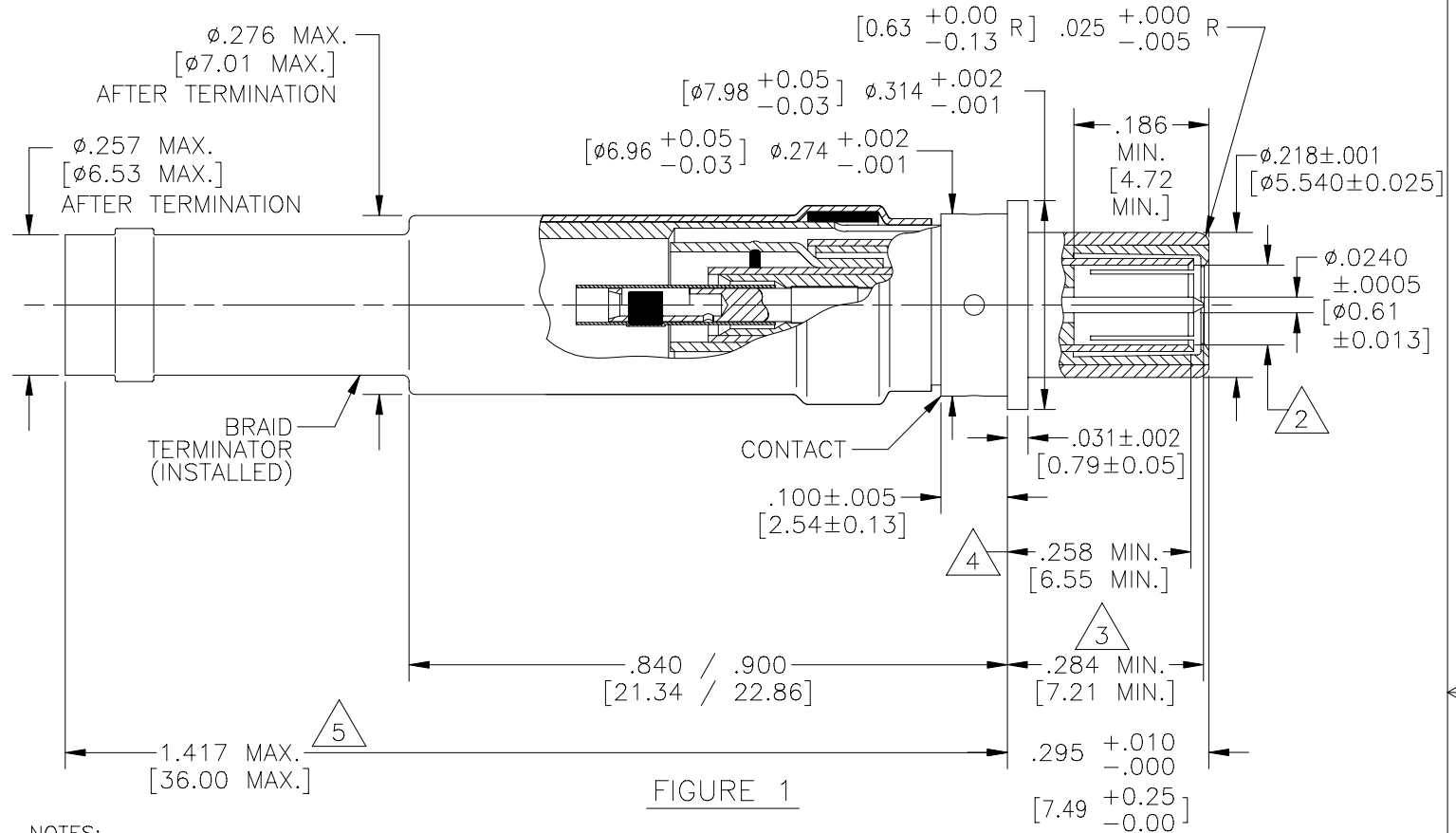
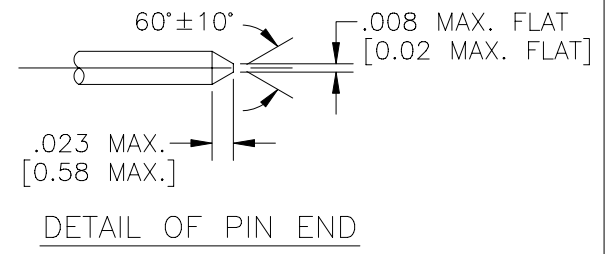

FIGURE 1

NOTES:

- 1. DIMENSIONS ARE AFTER PLATING.
- 2 SOCKET MATES WITH A .113 ± 0.001 [2.87 ± 0.025] DIAMETER PIN.
- 3 TO END OF CENTER PIN CONTACT.
- 4 POINT AT WHICH A SQUARE ENDED PIN OF THE SAME BASIC DIAMETER AS THE MATING CONTACT FIRST ENGAGES THE INTERMEDIATE CONTACT SPRING. PROVISION FOR CLEARANCE HOLE SHALL BE PROVIDED FOR THE TEST PIN.
- 5 THIS DIMENSION APPLIES ONLY TO DK-602-0156-N-4 AND -8.



SPECIFICATION CONTROL DRAWING

UNLESS OTHERWISE SPECIFIED DIMENSIONS ARE IN INCHES. METRIC DIMENSIONS ARE IN BRACKETS.

DECIMALS
 .XXX ± _____
 .XX ± _____
 ANGLES _____

WEIGHT
 SEE TABLE 1 (SHEET 2)

DRAWN	JOHN B. KAY	95 APR 28
CHECKED	JOHN B. KAY	6/15/95
APPROVED	M.HIGGY	6/15/95
APPROVED		
CAD NAME	T21270-1.DWG	
THIRD ANGLE PROJECTION		

tyco Electronics		Raychem Products		Tyco Electronics Corporation 305 Constitution Drive Menlo Park, CA 94025 U.S.A.	
TITLE PIN, SOLDER TACT®, SIZE 8 MIL-C-39029/90					
SIZE	CODE IDENT. NO.	DWG. NO.	REV		
A	06090	DK-602-0156-N-X	A		
DO NOT SCALE THIS DRAWING			SHEET 1 OF 5		

SEE SHEET 1 FOR REVISION

CONFIGURATION:

DK-602-0156-N-X IS A KIT, PER FIGURE 1, WHICH MAY CONTAIN A D-602-0156-N CONTACT, BRAID TERMINATOR AND ALIGNMENT/SEALING GROMMET (IS NOT SHOW) AS DESCRIBED IN TABLE I. NOTE: THE SUFFIX OF THE KIT PART NUMBER FOR THE PROPER MATCH OF THE CABLE SIZE, BRAID TERMINATOR AND GROMMET TYPE.

KIT PART NUMBER	BRAID TERMINATOR	GROMMET	CABLE O.D.	KIT WEIGHT, GRAMS MAX.
DK-602-0156-N-0	-	①	.180 MAX.	-
DK-602-0156-N-1	D-600-0044-1	①	.140 MAX.	3.96
DK-602-0156-N-2	D-600-0044-2	①	.155 MAX.	3.95
DK-602-0156-N-3	D-600-0044-3	①	.170 MAX.	3.87
DK-602-0156-N-4	D-600-0044-4	①	.180 MAX.	4.63
DK-602-0156-N-5	D-600-0044-1	D-600-0071	.140 MAX.	-
DK-602-0156-N-6	D-600-0044-2	D-600-0071	.155 MAX.	-
DK-602-0156-N-7	D-600-0044-3	D-600-0071	.170 MAX.	-
DK-602-0156-N-8	D-600-0044-4	D-600-0071	.180 MAX.	-
DK-602-0156-N-9	-	D-600-0125 ②	.180 MAX.	-

- ① INTENDED TO BE USED WITH COSTUMER SUPPLIED GROMMET. PERFORMANCE IS RESPONSIBILITY OF THE COSTUMER.
- ② D-600-0125 SHORT GROMMET IS INTENDED FOR USE ONLY WITHOUT BRAID TERMINATOR.

QUALIFICATION: THIS CONTACT MEETS THE REQUIREMENTS OF U.S. AIR FORCE DRAWING 8912020.

REQUIREMENTS: DIMENSIONS (FIGURE 1), DESIGN CHARACTERISTICS, AND CONFIGURATIONS MEET THE REQUIREMENTS OF M39029/90, EXCEPT THAT THE TEMPERATURE RATING IS 125°C INSTEAD OF 175°C. TERMINATION IS BY SOLDERING INSTEAD OF CRIMPING. SEE TABLE II FOR CABLE ACCOMMODATIONS. THIS DESIGN, WHICH PROVIDES THE INDUSTRY STANDARD MATING SEQUENCE (SHIELD, INTERMEDIATE, CENTER CONTACT), IS AN IMPROVED VERSION OF THE EXISTING RAYCHEM SOLDERTACT® P/N DK-602-0156 SERIES. THIS SEQUENCE IS NOT GUARANTEED BY THE M39029/90 INTERFACE DIMENSIONS.

CONTACT CAVITY SIZE	KIT PART NUMBER	CABLES ACCOMMODATED ③	TYPE	CLASS
8	DK-602-0156-N-1 DK-602-0156-N-2 DK-602-0156-N-3 DK-602-0156-N-4	RAYCHEM 10612 RAYCHEM 10613 RAYCHEM 10614	(D) COPPER ALLOY SHIELDED	(A) 125°C

- ③ OTHER APPLICATIONS SHOULD BE SUBMITTED TO TYCO ELECTRONICS/RAYCHEM FOR EVALUATION.

MATING CONTACT: D-602-0157-N-X AND M39029/91.

SHEET 2 OF 5	DRAWN	J.B.KAY	95 APR 28	SIZE	CODE IDENT. NO.	DWG. NO.	REV
	ISSUED			A	06090	DK-602-0156-N-X	A
				DO NOT SCALE THIS DRAWING		CAD NAME T21270-2.DWG	SCALE: NONE

SEE SHEET 1 FOR REVISION

TOOLS: SEE TABLE III.

HEATING TOOLS ④	REFLECTORS ④	HOLDING FIXTURES ④	INSTALLING TOOLS	REMOVAL TOOLS
AA-400 SUPER HEATER	MINI SOLDER SLEEVE	RAYCHEM	M81969/14-06	M81969/14-06
STEINEL HOT AIR GUN HL-1802E-KIT-120	STEINEL NOZZEL 07460	AD-1319 WITH AT-1319-14	M81969/46-06	M81969/46-12

④ SEE TERMINATION PROCEDURE: RAYCHEM ES 61231

ELECTRICAL PERFORMANCE:

CONTACT RESISTANCE: SEE TABLE IV

TEST CABLE	MAXIMUM VOLTAGE DROP (MILLIVOLTS)									TEST CURRENT (AMPS)		
	25° +3° -0° C			⑤ 25° +3° -0° C			125° +3° -0° C					
	CONTACT											
	I N N E R	M I D D L E	O U T E R	I N N E R	M I D D L E	O U T E R	I N N E R	M I D D L E	O U T E R	I N N E R	M I D D L E	O U T E R
<u>RAYCHEM</u>												
10612	55	55	75	66	66	90	94	94	128	1.0	1.0	12.0
10613												
10614												

⑤ AFTER CONDITIONING.

LOW SIGNAL LEVEL CONTACT RESISTANCE: SEE TABLE V

TEST CABLE	MAXIMUM CONTACT RESISTANCE (MILLIOHMS)	
	INITIAL	AFTER CONDITIONING
	<u>RAYCHEM</u>	
10612	55	66
10613		
10614		

SHEET 3 OF 5	DRAWN	J.B.KAY	95 APR 28	SIZE	CODE IDENT. NO.	DWG. NO.	REV
	ISSUED			A	06090	DK-602-0156-N-X	A
				DO NOT SCALE THIS DRAWING		CAD NAME	T21270-3.DWG
						SCALE:	NONE

SEE SHEET 1 FOR REVISION

DIELECTRIC WITHSTANDING VOLTAGE: SEE TABLE VI

TABLE VI. DIELECTRIC WITHSTANDING VOLTAGE		
CONTACTS	ALTITUDE	TEST VOLTAGES, AC RMS
INNER TO MIDDLE	SEA LEVEL	1000
MIDDLE TO OUTER	SEA LEVEL	500

OPERATING FREQUENCY: 0 TO 20 MHZ (OPERATING FREQUENCY RANGE)

VOLTAGE RATING: 500 VOLTS RMS MAXIMUM AT SEA LEVEL; 125 VOLTS AT 70,000 FEET

MECHANICAL PERFORMANCE:

CONTACT ENGAGEMENT AND SEPARATION FORCE (SOCKET CONTACTS ONLY): SEE TABLE VII

TABLE VII. CONTACT ENGAGEMENT AND SEPARATION FORCE				
TEST PIN DIAMETER (INCH)	MINIMUM SEPARATION FORCE (OUNCES)		MAXIMUM ENGAGEMENT FORCE (OUNCES)	
	INITIAL	AFTER CONDITIONING	INITIAL	AFTER CONDITIONING
.1140 ^{+0.0000} / _{-.0001}	NA	NA	18	22
.1120 ^{+0.0001} / _{-.0000}	0.5	0.4	NA	NA

TENSILE STRENGTH: SEE TABLE VIII

TABLE VIII. TENSILE STRENGTH (AT AMBIENT)			
TEST CABLE	TENSILE STRENGTH (POUNDS) (MINIMUM) ⑥		
	INNER CONTACT	MIDDLE CONTACT	OUTER CONTACT
<u>RAYCHEM</u>			
10612	8	8	15
10613	8	8	25
10614	8	8	25

⑥ CABLE MAY BREAK BEFORE THE SOLDER JOINT TERMINATION.

SHEET 4 OF 5	DRAWN	J.B.KAY	95 APR 28	SIZE	CODE IDENT. NO.	DWG. NO.	REV
	ISSUED			A	06090	DK-602-0156-N-X	A
				DO NOT SCALE THIS DRAWING		CAD NAME T21270-4.DWG	SCALE: NONE

SEE SHEET 1 FOR REVISION

VIBRATION: PER MIL-C-39029/90
 HIGH IMPACT SHOCK: PER MIL-C-39029/90

ENVIRONMENTAL PERFORMANCE:

OPERATING TEMPERATURE: -65°C TO +125°C
 HUMIDITY: PER MIL-C-39029/90

MATERIAL:

CONTACT	BERYLLIUM COPPER, ALLOY 173, CONDITION H, ASTM B196, PER MIL-C-39029, TYPE D
PLATING OF CONTACT	GOLD PLATE PER MIL-G-45204 TYPE II, GRADE C 50 MICROINCHES MINIMUM OVER NICKEL PER QQ-N-290A 50 MICROINCHES MINIMUM OVER COPPER STRIKE - 40 MICROINCHES MINIMUM
SOLDER	Sn63 PER QQ-S-571
FLUX	TYPE RMA PER MIL-F-14256
SHRINK TUBING	HEAT-SHRINKABLE, RADIATION-CROSSLINKED POLYVINYLIDENE FLUORIDE
DIELECTRIC	ETFE FLUOROPOLYMER PER ASTM D3159

SHEET 5 OF 5	DRAWN	J.B.KAY	95 APR 28	SIZE	CODE IDENT. NO.	DWG. NO.	REV
	ISSUED			A	06090	DK-602-0156-N-X	A
				DO NOT SCALE THIS DRAWING		CAD NAME T21270-5.DWG	SCALE: NONE