

REVISION		
REV	DESCRIPTION	DATE
B	REVISED DWG PER ECO-11-008908	28APR2011

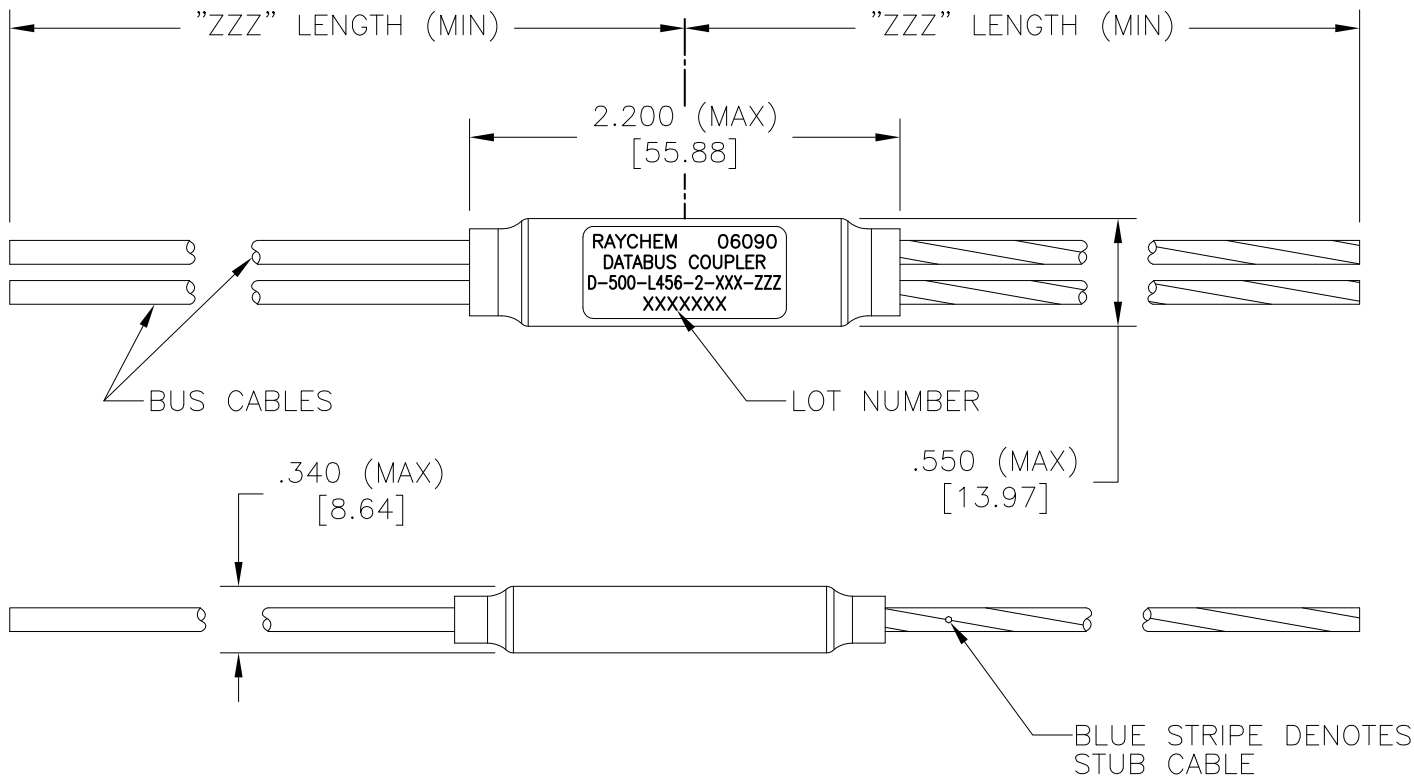

COMPONENT NUMBER



D-500-L456-2-XXX-ZZZ

SCHEMATIC 6: REVERSE
 NUMBER OF STUBS
 CABLE LENGTH (INCHES)
CABLE

- 612: 10612 (OPTIMIZED SINGLE SHIELD)
- 613: 10613 (OPTIMIZED DOUBLE SHIELD)
- 614: 10614 (EMP HARDENED)
- EP3: EPD30653Q (BUS), EPD31346A-6L9-US (STUB) (OPTIMIZED DOUBLE SHIELD)
- H06: 7724H0664 (FLAT SHIELD WIRE, UNFILLED)
- 6D0: 7726D0664 26 AWG OPTIMIZED SINGLE SHIELD
- 6D3: 7726D3664 26 AWG OPTIMIZED DOUBLE SHIELD

© 2011 Tyco Electronics Corporation. All Rights Reserved.

Raychem Databus
CUSTOMER DRAWING

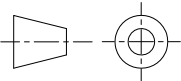
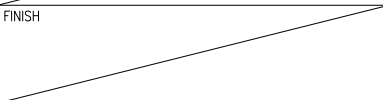
UNLESS OTHERWISE SPECIFIED DIMENSIONS ARE INCHES. METRIC DIMENSIONS ARE IN BRACKETS. DECIMAL TOLERANCES .XXX ±--- [---mm] .XX ±--- [---mm] .X ±--- [---mm] ANGLE TOLERANCE .X ±---	DRAWN G.Rositano	DATE 12/8/03		TE Connectivity
	MATERIAL 			TITLE DATABUS MICROCOUPLER, DOUBLE STUB, REVERSE LIGHTWEIGHT
THIRD ANGLE PROJECTION 	FINISH 	SIZE A	CODE IDENT. NO. 06090	DWG. NO. D-500-L456-2-XXX-ZZZ
	CAD FILE D-500-L456-2-XXX-ZZZa	DO NOT SCALE THIS DRAWING		SHEET 1 OF 2

1. MATERIAL AND FINISHES:
 - 1.1 INTERNAL COMPONENTS:
 - TRANSFORMER TO MIL-PRF-21038 AND MIL-STD-1553B
 - RESISTORS TO MIL-PRF-39007/9, 57.6 OHMS
 - 1.2 SHIELDED CASE: ALUMINUM PER ASTM-B618.
 - 1.3 SEALED COVER: MODIFIED CROSS-LINKED, FLAME RETARDANT, BLACK, FLUOROPOLYMER TO RAYCHEM SPECIFICATION RW3016.
 - 1.4 CABLE TO RAYCHEM SPECIFICATION 1200 (SEE PART NO. ON SHEET 1).
2. APPLICATION:
 - 2.1 THIS COUPLER IS DESIGNED TO BE INSTALLED INTO A DIGITAL MULTIPLEX ASSEMBLY MEETING THE REQUIREMENTS OF MIL-STD-1553B.
 - 2.2 FOR CABLE SPLICING USE FLEXIBLE SPLICE KIT D-150-0708-5 (NOT SUPPLIED).
 - 2.3 CABLE BEND RADIUS PER SAE-AS50881 STATIC BEND: 5 x CABLE O.D. MIN.
DYNAMIC BEND: 10 x CABLE O.D. MIN.
3. TEMPERATURE:
 - 3.1 OPERATING TEMPERATURE: -65°C TO +150°C
4. PERFORMANCE SPECIFICATIONS:
 - 4.1 COUPLER MEETS THE PERFORMANCE REQUIREMENTS OF MIL-STD-1553B.
5. WEIGHT:
 - 5.1 WEIGHT WITHOUT CABLE: 9.5 GRAMS (MAXIMUM).

DOUBLE STUB COUPLER SCHEMATIC

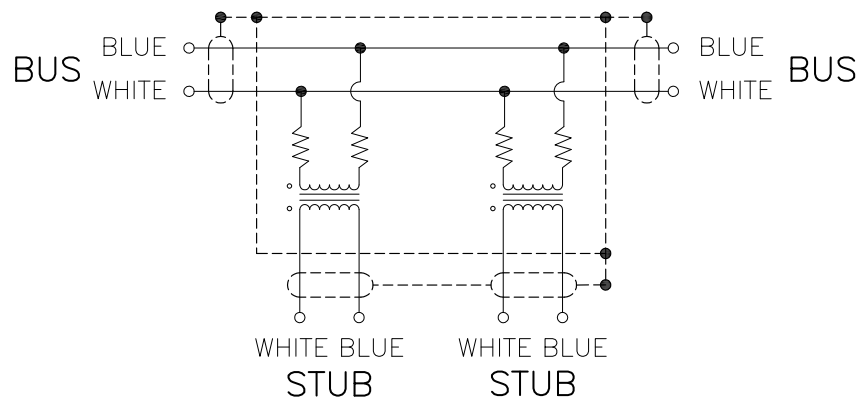

© 2011 Tyco Electronics Corporation. All Rights Reserved.

Raychem Databus
CUSTOMER DRAWING

DRAWN G.Rositano	DATE 12/8/03	SIZE A	CODE IDENT. NO. 06090	DWG. NO. D-500-L456-2-XXX-ZZZ	REV B
CAD FILE D-500-L456-2-XXX-ZZZb				DO NOT SCALE THIS DRAWING	
				SHEET 2 OF 2	