

REVISIONS			
REV	DESCRIPTION	DATE	APPROVED
D	REVISED PER ECN T-28195	03OCT00	TR

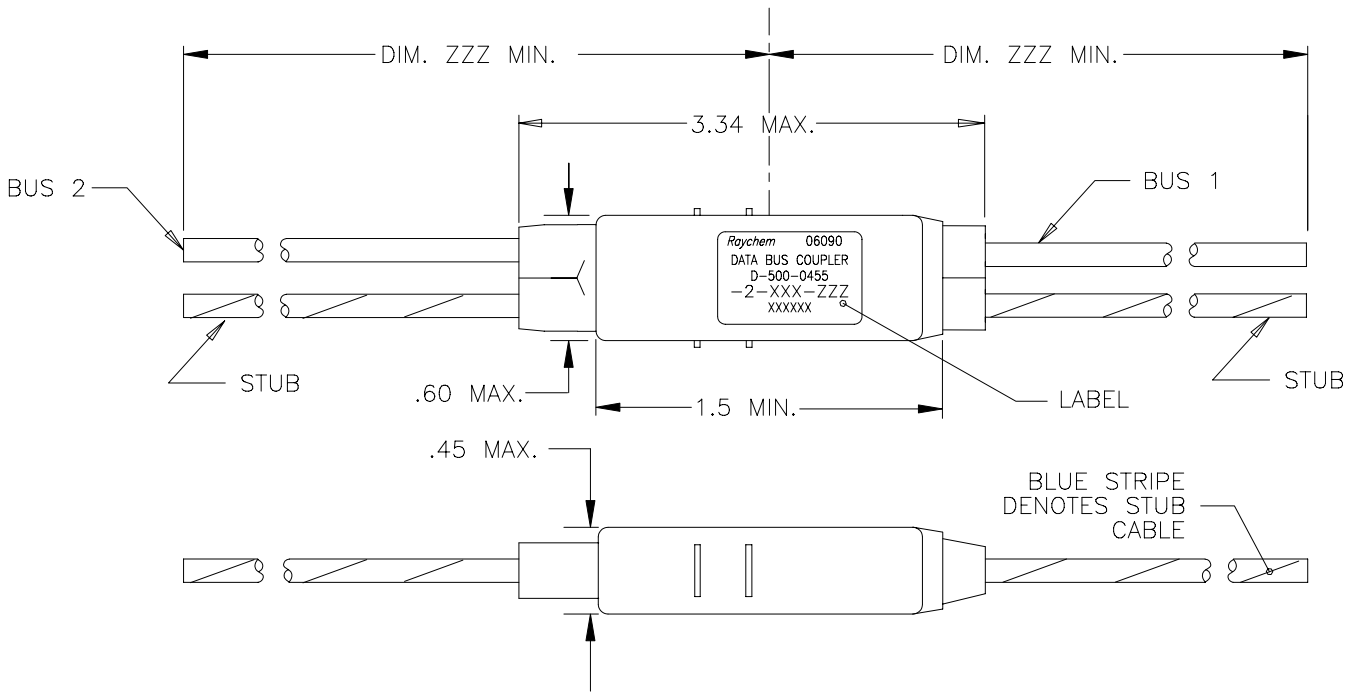

COMPONENT NUMBER	BUS CABLE	STUB CABLE
D-500-0455-2-612-ZZZ	10612-24-9	10612-24-96
D-500-0455-2-613-ZZZ	10613-24-9	10613-24-96
D-500-0455-2-614-ZZZ	10614-24-9	10614-24-96
D-500-0455-2-C26-ZZZ	7724C2664-9	7724C2664-96
D-500-0455-2-H06-ZZZ	7724H0664-9	7724H0664-96

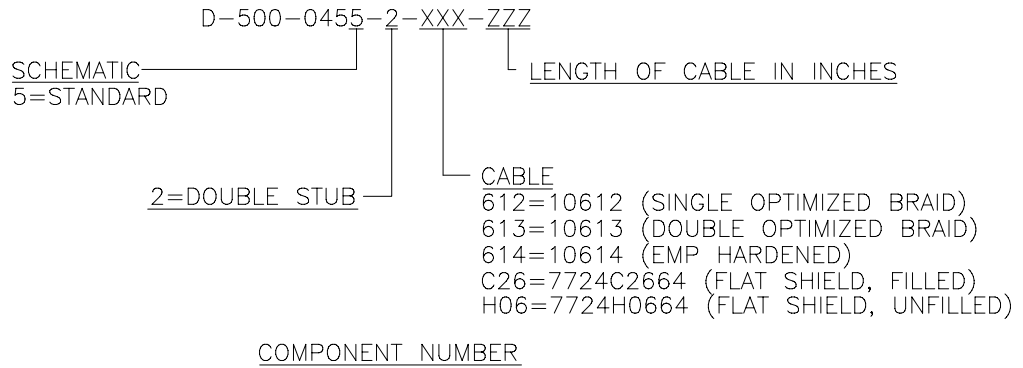

## SPECIFICATION CONTROL DRAWING

UNLESS OTHERWISE SPECIFIED  
DIMENSIONS ARE IN INCHES.  
METRIC DIMENSIONS ARE  
IN BRACKETS.

DECIMALS  
.XXX ± — { — mm }  
.XX ± — { — mm }  
ANGLES  
.X ± —

WEIGHT

DRAWN	ZS.O.	3/31/98
CHECKED		
APPROVED		
APPROVED	M.HIGGY	3/31/98
CAD NAME	T28195A.dwg	
THIRD ANGLE PROJECTION		

<b>tyco</b> <b>Electronics</b>		Tyco Electronics Corporation 300 Constitution Drive Menlo Park, CA. 94025 U.S.A.	<b>Raychem</b>
TITLE TWO STUB IN-LINE DATA BUS MICRO COUPLER 04 SERIES STANDARD			
SIZE A	CODE IDENT. NO. 06090	DWG. NO. D-500-0455-2-XXX-ZZZ	
DO NOT SCALE THIS DRAWING			SHEET 1 OF 2

1. MATERIAL AND FINISHES:
  - 1.1 INTERNAL COMPONENTS:
    - TRANSFORMER TO MIL-T-21038 AND MIL-STD-1553/B
    - RESISTORS TO PER MIL-R-39007/9, 57.6 OHMS
  - 1.2 SHIELDED CASE: ALUMINUM PER ASTM B 618, ALLOY A03560 COND. F. OR ASTM B211, ALLOY A92017.
  - 1.3 SEALED STRAIN RELIEF COVER: MODIFIED CROSS-LINKED ELASTOMER, BLACK, TO RAYCHEM SPECIFICATION RK-6713.
  - 1.4 CABLE (SEE CABLE TABULATION, SHEET 1). TO RAYCHEM SPECIFICATION 1200.
2. APPLICATION:
  - 2.1 THIS COUPLER IS DESIGNED TO BE INSTALLED INTO A DIGITAL MULTIPLEX ASSEMBLY MEETING THE REQUIREMENTS OF MIL-STD-1553B.
    - 2.1.1 FOR CABLE SPLICING USE FLEXIBLE SPLICE KIT D-150-9133.
  - 2.2 FOR NETWORK LAYOUT ASSISTANCE CONSULT RAYCHEM TECHNICAL SERVICES.
  - 2.3 CABLE BEND RADIUS PER MIL-W-5088 STATIC BEND: 5 x CABLE O.D. MIN.  
DYNAMIC BEND: 10 x CABLE O.D. MIN.
3. TEMPERATURE:
  - 3.1 OPERATING TEMPERATURE: -65°C TO +150°C
4. PERFORMANCE SPECIFICATIONS:
  - 4.1 TRANSFORMER MEETS THE PERFORMANCE REQUIREMENTS OF MIL-STD-1553B.
  - 4.2 COUPLER WILL BE QUALIFIED TO RAYCHEM SPECIFICATION D-6020. QUALIFICATION PENDING.
5. WEIGHT:
  - 5.1 MAXIMUM WEIGHT WITHOUT CABLE: 15 GRAMS MAX.
6. ORDERING INFORMATION:

ORDER PER COMPONENT NUMBER. (SEE SHEET 1) AND DESIRED "ZZZ" CABLE LENGTH. SPLICE KITS TO BE ORDERED SEPARATELY.  
SPECIFY CERTIFICATION OF CONFORMANCE REQUIREMENTS AS SEPARATE LINE ITEM.

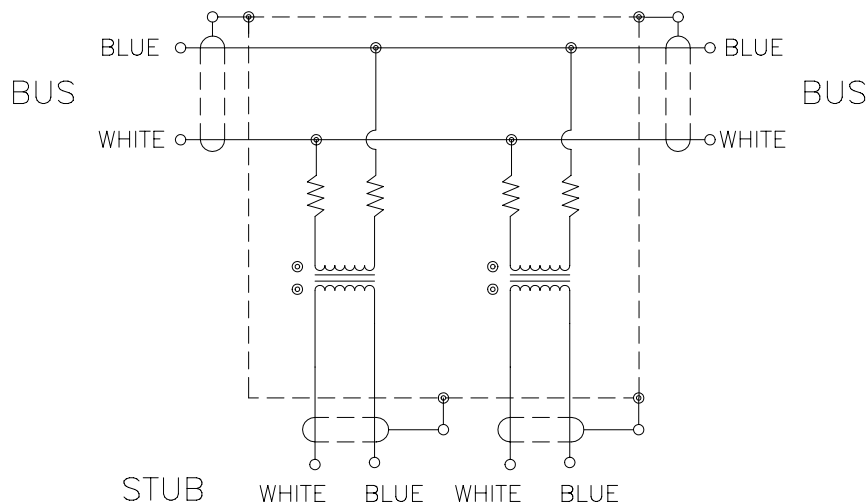
TWO STUB COUPLER SCHEMATIC

CAD NAME: T28195B

DRAWN

ZS.O.

3/31/98

SIZE

CODE IDENT. NO.

DWG. NO.

REV

A

06090

D-500-0455-2-XXX-ZZZ

D

ISSUED

DO NOT SCALE THIS DRAWING

SHEET 2 OF 2