

SOJ, TSOP, FP-BGA  
Commercial Temp  
Industrial Temp

# 256K x 16

## 4Mb Asynchronous SRAM

7, 8, 10, 12 ns  
3.3 V  $V_{DD}$   
Center  $V_{DD}$  and  $V_{SS}$

### Features

- Fast access time: 7, 8, 10, 12 ns
- CMOS low power operation: 150/130/105/95 mA at minimum cycle time
- Single 3.3 V power supply
- All inputs and outputs are TTL-compatible
- Byte control
- Fully static operation
- Industrial Temperature Option:  $-40^{\circ}$  to  $85^{\circ}\text{C}$
- Package line up
  - J: 400 mil, 44-pin SOJ package
  - TP: 400 mil, 44-pin TSOP Type II package
  - X: 6 mm x 10 mm Fine Pitch Ball Grid Array package

### Description

The GS74116A is a high speed CMOS Static RAM organized as 262,144 words by 16 bits. Static design eliminates the need for external clocks or timing strobes. The GS operates on a single 3.3 V power supply and all inputs and outputs are TTL-compatible. The GS74116A is available in a 6 x 10 mm Fine Pitch BGA package, 400 mil SOJ and 400 mil TSOP Type-II packages.

### SOJ 256K x 16-Pin Configuration (Package J)

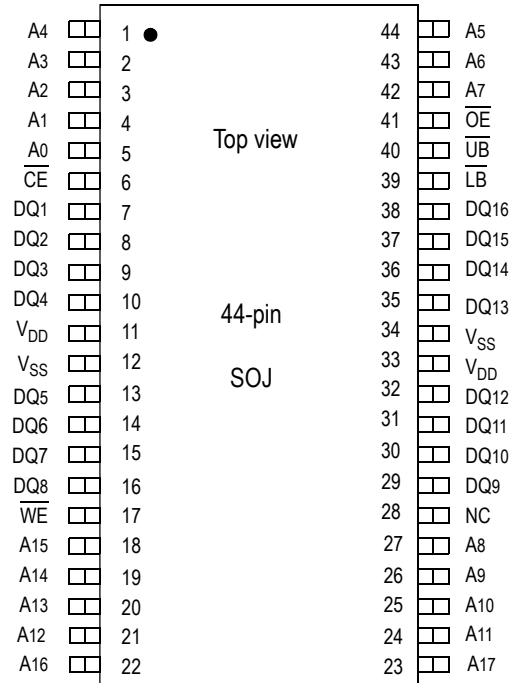

### Pin Descriptions

Symbol	Description
A <sub>0</sub> –A <sub>17</sub>	Address input
DQ <sub>1</sub> –DQ <sub>16</sub>	Data input/output
$\overline{\text{CE}}$	Chip enable input
$\overline{\text{LB}}$	Lower byte enable input (DQ <sub>1</sub> to DQ <sub>8</sub> )
$\overline{\text{UB}}$	Upper byte enable input (DQ <sub>9</sub> to DQ <sub>16</sub> )
$\overline{\text{WE}}$	Write enable input
$\overline{\text{OE}}$	Output enable input
$V_{DD}$	+3.3 V power supply
$V_{SS}$	Ground
NC	No connect

### FP-BGA 256K x 16 Bump Configuration (Package X)

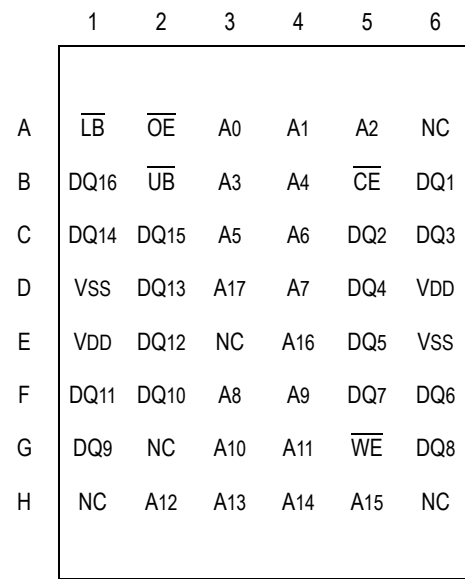

Top View

TSOP-II 256K x 16 Pin Configuration (Package TP)

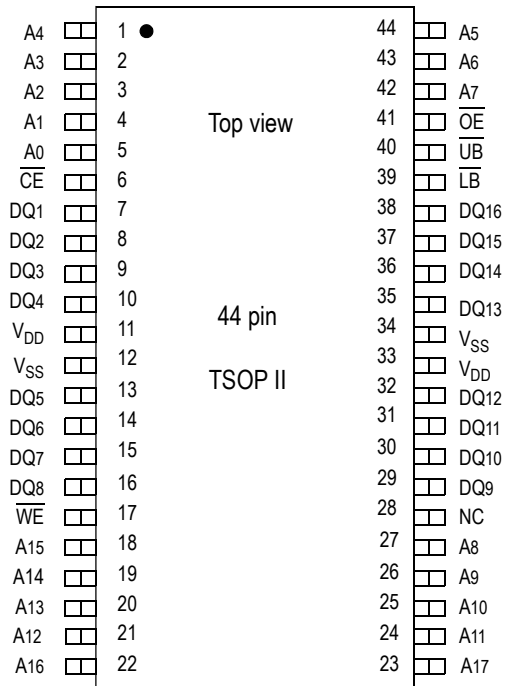

Block Diagram

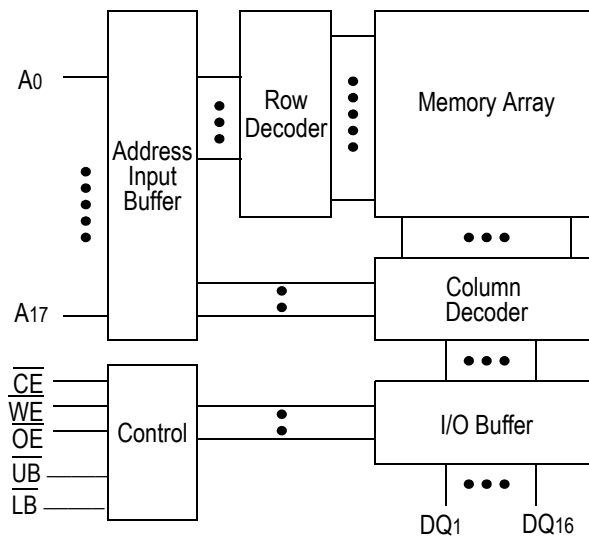

**Truth Table**

$\overline{\text{CE}}$	$\overline{\text{OE}}$	$\overline{\text{WE}}$	$\overline{\text{LB}}$	$\overline{\text{UB}}$	DQ1 to DQ8	DQ9 to DQ16	VDD Current
H	X	X	X	X	Not Selected	Not Selected	ISB1, ISB2
L	L	H	L	L	Read	Read	I <sub>DD</sub>
			L	H	Read	High Z	
			H	L	High Z	Read	
L	X	L	L	L	Write	Write	
			L	H	Write	Not Write, High Z	
			H	L	Not Write, High Z	Write	
L	H	H	X	X	High Z	High Z	
L	X	X	H	H	High Z	High Z	

Note: X: "H" or "L"

**Absolute Maximum Ratings**

Parameter	Symbol	Rating	Unit
Supply Voltage	V <sub>DD</sub>	-0.5 to +4.6	V
Input Voltage	V <sub>IN</sub>	-0.5 to V <sub>DD</sub> +0.5 (≤ 4.6 V max.)	V
Output Voltage	V <sub>OUT</sub>	-0.5 to V <sub>DD</sub> +0.5 (≤ 4.6 V max.)	V
Allowable power dissipation	PD	0.7	W
Storage temperature	T <sub>STG</sub>	-55 to 150	°C

Note:

Permanent device damage may occur if Absolute Maximum Ratings are exceeded. Functional operation shall be restricted to Recommended Operating Conditions. Exposure to higher than recommended voltages for extended periods of time could affect device reliability.

## Recommended Operating Conditions

Parameter	Symbol	Min	Typ	Max	Unit
Supply Voltage for -7/-8/-10/-12	$V_{DD}$	3.0	3.3	3.6	V
Input High Voltage	$V_{IH}$	2.0	—	$V_{DD} + 0.3$	V
Input Low Voltage	$V_{IL}$	-0.3	—	0.8	V
Ambient Temperature, Commercial Range	$T_{Ac}$	0	—	70	°C
Ambient Temperature, Industrial Range	$T_{AI}$	-40	—	85	°C

Note:

1. Input overshoot voltage should be less than  $V_{DD} + 2\text{ V}$  and not exceed 20 ns.
2. Input undershoot voltage should be greater than  $-2\text{ V}$  and not exceed 20 ns.

## Capacitance

Parameter	Symbol	Test Condition	Max	Unit
Input Capacitance	$C_{IN}$	$V_{IN} = 0\text{ V}$	5	pF
Output Capacitance	$C_{OUT}$	$V_{OUT} = 0\text{ V}$	7	pF

Notes:

1. Tested at  $T_A = 25^\circ\text{C}$ ,  $f = 1\text{ MHz}$
2. These parameters are sampled and are not 100% tested.

## DC I/O Pin Characteristics

Parameter	Symbol	Test Conditions	Min	Max
Input Leakage Current	$I_{IL}$	$V_{IN} = 0\text{ to }V_{DD}$	-1 $\mu\text{A}$	1 $\mu\text{A}$
Output Leakage Current	$I_{LO}$	Output High Z $V_{OUT} = 0\text{ to }V_{DD}$	-1 $\mu\text{A}$	1 $\mu\text{A}$
Output High Voltage	$V_{OH}$	$I_{OH} = -4\text{ mA}$	2.4	—
Output Low Voltage	$V_{OL}$	$I_{LO} = +4\text{ mA}$	—	0.4 V

**Power Supply Currents**

Parameter	Symbol	Test Conditions	0 to 70°C				-40 to 85°C				Unit
			7 ns	8 ns	10 ns	12 ns	7 ns	8 ns	10 ns	12 ns	
Operating Supply Current	I <sub>DD</sub>	$\overline{CE} \leq V_{IL}$ All other inputs $\geq V_{IH}$ or $\leq V_{IL}$ Min. cycle time I <sub>OUT</sub> = 0 mA	150	130	105	90	160	140	115	100	mA
Standby Current	I <sub>SB1</sub>	$\overline{CE} \geq V_{IH}$ All other inputs $\geq V_{IH}$ or $\leq V_{IL}$ Min. cycle time	40	30	25	25	50	40	35	35	mA
Standby Current	I <sub>SB2</sub>	$\overline{CE} \geq V_{DD} - 0.2V$ All other inputs $\geq V_{DD} - 0.2V$ or $\leq 0.2V$	10				20				mA

**AC Test Conditions**

Parameter	Conditions
Input high level	V <sub>IH</sub> = 2.4 V
Input low level	V <sub>IL</sub> = 0.4 V
Input rise time	t <sub>r</sub> = 1 V/ns
Input fall time	t <sub>f</sub> = 1 V/ns
Input reference level	1.4 V
Output reference level	1.4 V
Output load	<b>Fig. 1 &amp; 2</b>

Note:

1. Include scope and jig capacitance.
2. Test conditions as specified with output loading as shown in **Fig. 1** unless otherwise noted.
3. Output load 2 for t<sub>LZ</sub>, t<sub>HZ</sub>, t<sub>OLZ</sub> and t<sub>OZH</sub>

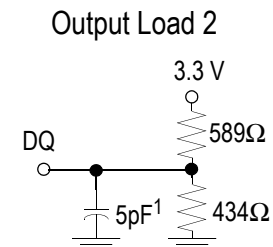
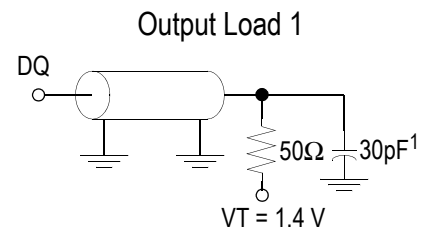

**AC Characteristics**
**Read Cycle**

Parameter	Symbol	-7		-8		-10		-12		Unit
		Min	Max	Min	Max	Min	Max	Min	Max	
Read cycle time	t <sub>RC</sub>	7	—	8	—	10	—	12	—	ns
Address access time	t <sub>AA</sub>	—	7	—	8	—	10	—	12	ns
Chip enable access time ( $\overline{CE}$ )	t <sub>AC</sub>	—	7	—	8	—	10	—	12	ns
Byte enable access time ( $\overline{UB}$ , $\overline{LB}$ )	t <sub>AB</sub>	—	3	—	3.5	—	4	—	5	ns
Output enable to output valid ( $\overline{OE}$ )	t <sub>OE</sub>	—	3	—	3.5	—	4	—	5	ns
Output hold from address change	t <sub>OH</sub>	3	—	3	—	3	—	3	—	ns
Chip enable to output in low Z ( $\overline{CE}$ )	t <sub>LZ</sub> *	3	—	3	—	3	—	3	—	ns
Output enable to output in low Z ( $\overline{OE}$ )	t <sub>OLZ</sub> *	0	—	0	—	0	—	0	—	ns
Byte enable to output in low Z ( $\overline{UB}$ , $\overline{LB}$ )	t <sub>BLZ</sub> *	0	—	0	—	0	—	0	—	ns
Chip disable to output in High Z ( $\overline{CE}$ )	t <sub>HZ</sub> *	—	3.5	—	4	—	5	—	6	ns
Output disable to output in High Z ( $\overline{OE}$ )	t <sub>OHZ</sub> *	—	3	—	3.5	—	4	—	5	ns
Byte disable to output in High Z ( $\overline{UB}$ , $\overline{LB}$ )	t <sub>BHZ</sub> *	—	3	—	3.5	—	4	—	5	ns

\* These parameters are sampled and are not 100% tested.

**Read Cycle 1:  $\overline{CE} = \overline{OE} = V_{IL}$ ,  $\overline{WE} = V_{IH}$ ,  $\overline{UB}$  and, or  $\overline{LB} = V_{IL}$**

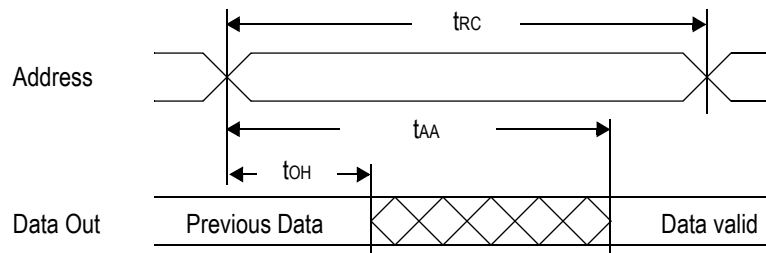

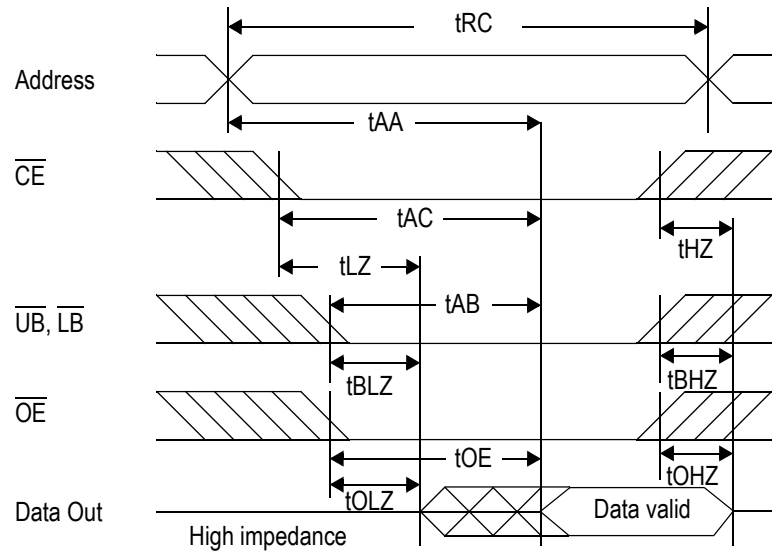
**Read Cycle 2:  $\overline{WE} = V_{IH}$** 

**Write Cycle**

Parameter	Symbol	-7		-8		-10		-12		Unit
		Min	Max	Min	Max	Min	Max	Min	Max	
Write cycle time	tWC	7	—	8	—	10	—	12	—	ns
Address valid to end of write	tAW	5	—	5.5	—	7	—	8	—	ns
Chip enable to end of write	tCW	5	—	5.5	—	7	—	8	—	ns
Byte enable to end of write	tBW	5	—	5.5	—	7	—	8	—	ns
Data set up time	tDW	3.5	—	4	—	4.5	—	6	—	ns
Data hold time	tDH	0	—	0	—	0	—	0	—	ns
Write pulse width	tWP	5	—	5.5	—	7	—	8	—	ns
Address set up time	tAS	0	—	0	—	0	—	0	—	ns
Write recovery time ( $\overline{WE}$ )	tWR	0	—	0	—	0	—	0	—	ns
Write recovery time ( $\overline{CE}$ )	tWR1	0	—	0	—	0	—	0	—	ns
Output Low Z from end of write	tWLZ*	3	—	3	—	3	—	3	—	ns
Write to output in High Z	tWHZ*	—	3	—	3.5	—	4	—	5	ns

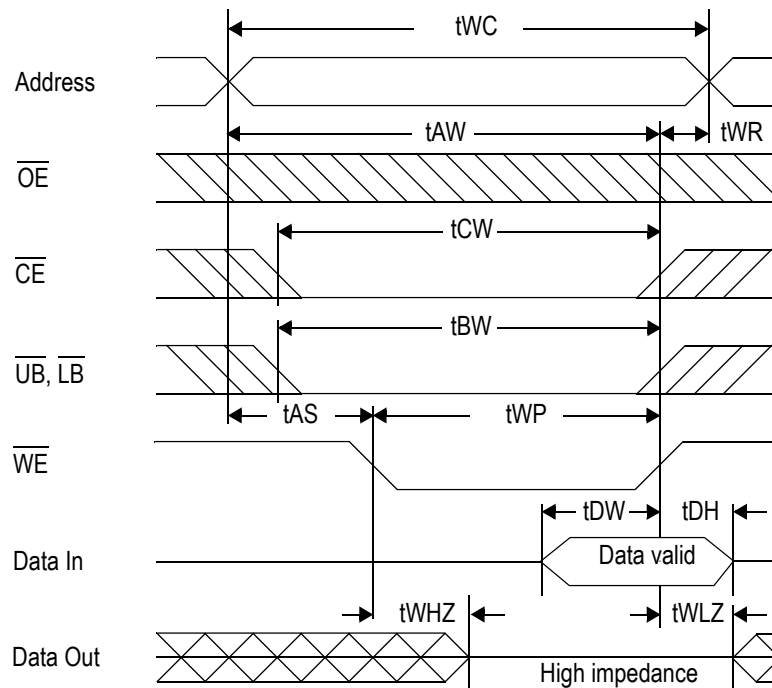
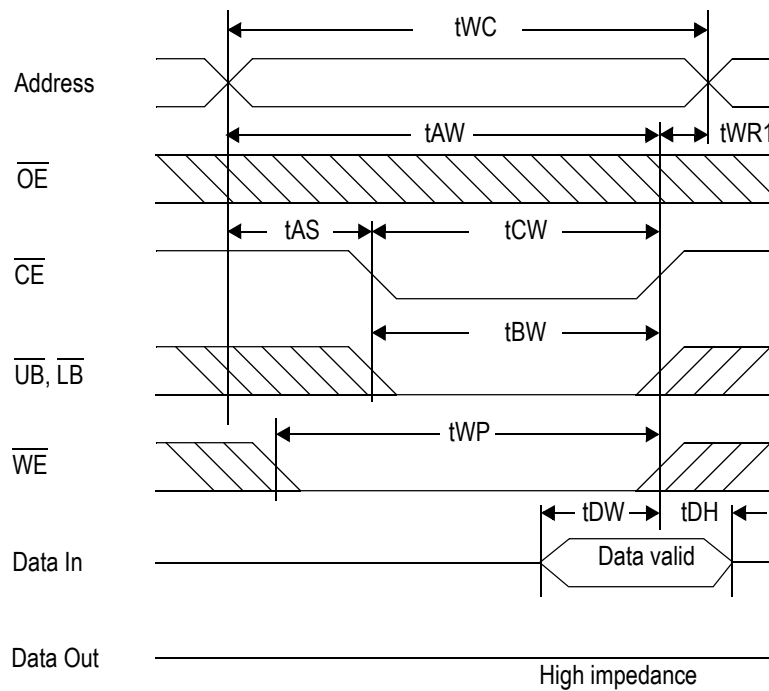
\* These parameters are sampled and are not 100% tested.

**Write Cycle 1:  $\overline{\text{WE}}$  control**

**Write Cycle 2:  $\overline{\text{CE}}$  control**

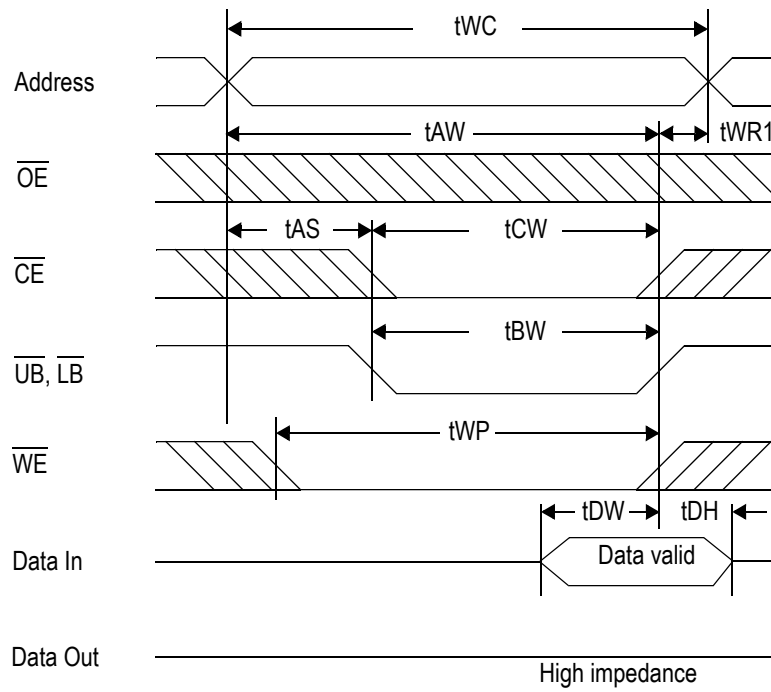

Write Cycle 3:  $\overline{UB}$ ,  $\overline{LB}$  control

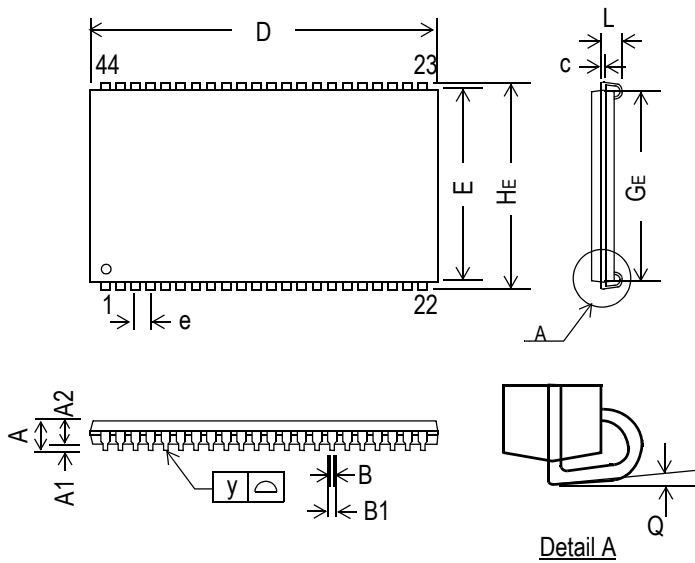

**44-Pin, 400 mil SOJ**

Symbol	Dimension in inch			Dimension in mm		
	min	nom	max	min	nom	max
A	—	—	0.148	—	—	3.759
A1	0.025	—	—	0.635	—	—
A2	0.105	0.110	0.115	2.667	2.794	2.921
B	—	0.018	—	—	0.457	—
B1	0.026	0.028	0.032	0.660	0.711	0.813
c	—	0.008	—	—	0.203	—
D	1.120	1.125	1.130	28.44	28.58	28.70
E	0.395	0.400	0.405	10.033	10.160	10.287
e	—	0.05	—	—	1.27	—
HE	0.435	0.440	0.445	11.049	11.176	11.303
GE	0.360	0.370	0.380	9.144	9.398	9.652
L	0.082	0.087	0.106	2.083	2.210	2.70
y	—	—	0.004	—	—	0.102
Q	0°	—	7°	0°	—	7°

**Notes:**

1. Dimension D & E do not include interlead flash
2. Dimension B1 does not include dambar protrusion / intrusion
3. Controlling dimension: inches

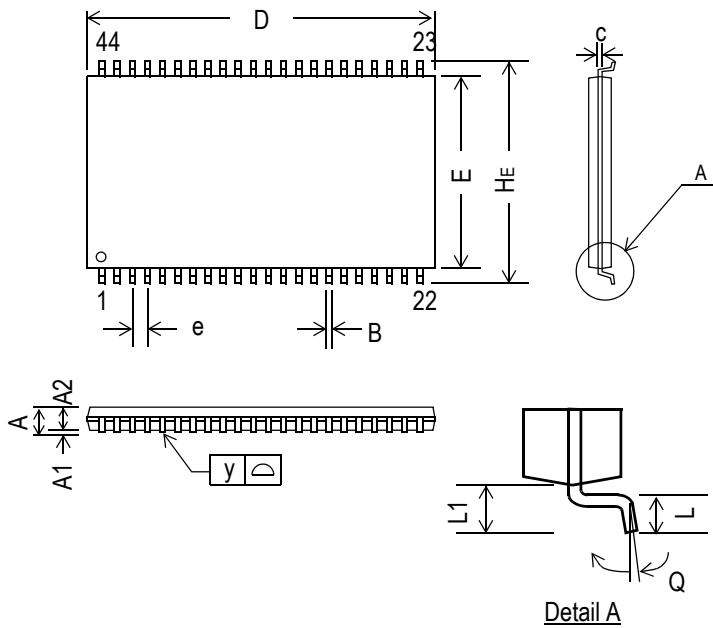
**44-Pin, 400 mil TSOP-II**

Symbol	Dimension in inch			Dimension in mm		
	min	nom	max	min	nom	max
A	—	—	0.047	—	—	1.20
A1	0.002	—	—	0.05	—	—
A2	0.037	0.039	0.041	0.95	1.00	1.05
B	0.01	0.014	0.018	0.25	0.35	0.45
c	—	0.006	—	—	0.15	—
D	0.721	0.725	0.729	18.31	18.41	18.51
E	0.396	0.400	0.404	10.06	10.16	10.26
e	—	0.031	—	—	0.80	—
HE	0.455	0.463	0.471	11.56	11.76	11.96
L	0.016	0.020	0.024	0.40	0.50	0.60
L1	—	0.031	—	—	0.80	—
y	—	—	0.004	—	—	0.10
Q	0°	—	5°	0°	—	5°

**Notes:**

1. Dimension D & E do not include interlead flash.
2. Dimension B does not include dambar protrusion/intrusion.
3. Controlling dimension: mm

6 mm x 10 mm FP-BGA

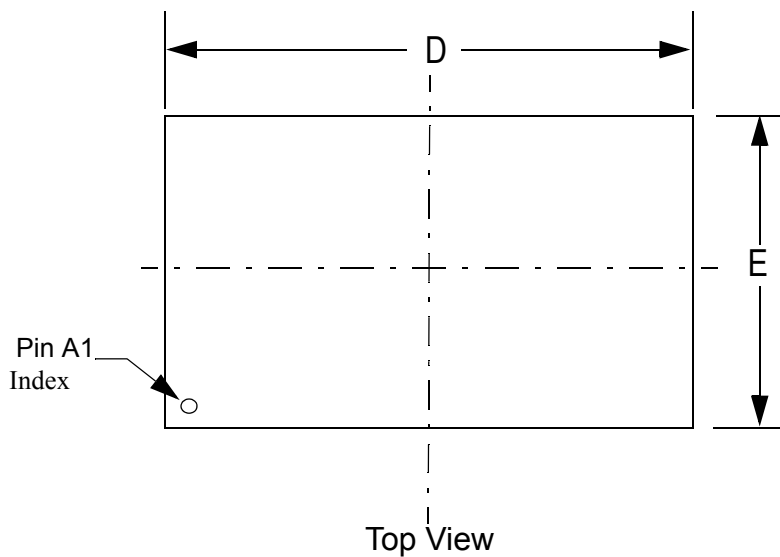

Symbol	Unit: mm
A	1.10±0.10
A1	0.20~0.30
fb	f0.30~0.40
c	0.36(TYP)
D	10.0±0.05
D1	5.25
E	6.0±0.05
E1	3.75
e	0.75(TYP)
aaa	0.10

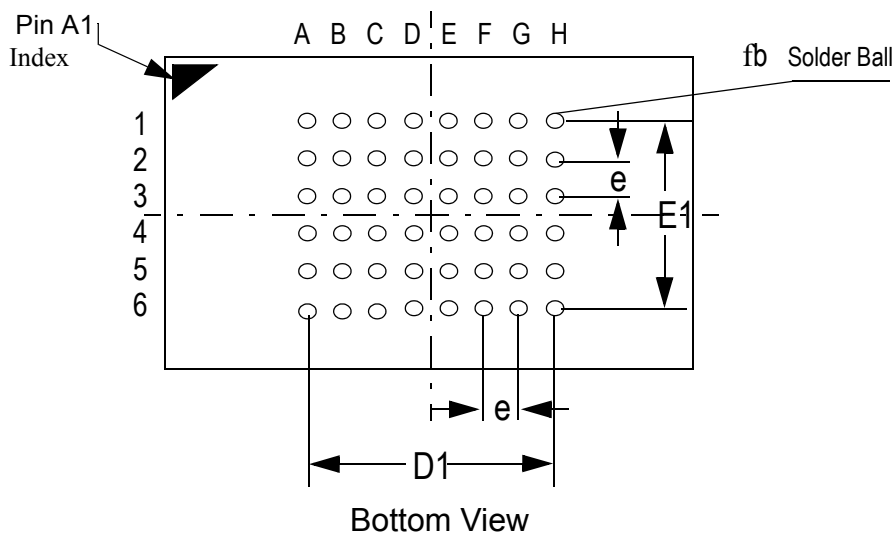
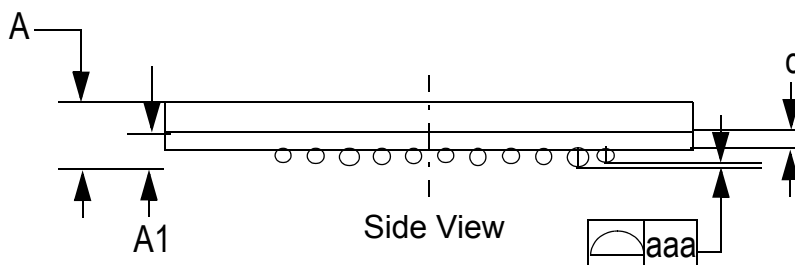

**Ordering Information**

Part Number *	Package	Access Time	Temp. Range	Status
GS74116ATP-7	400 mil TSOP-II	7 ns	Commercial	
GS74116ATP-8	400 mil TSOP-II	8 ns	Commercial	
GS74116ATP-10	400 mil TSOP-II	10 ns	Commercial	
GS74116ATP-12	400 mil TSOP-II	12 ns	Commercial	
GS74116ATP-7I	400 mil TSOP-II	7 ns	Industrial	
GS74116ATP-8I	400 mil TSOP-II	8 ns	Industrial	
GS74116ATP-10I	400 mil TSOP-II	10 ns	Industrial	
GS74116ATP-12I	400 mil TSOP-II	12 ns	Industrial	
GS74116AJ-7	400 mil SOJ	7 ns	Commercial	
GS74116AJ-8	400 mil SOJ	8 ns	Commercial	
GS74116AJ-10	400 mil SOJ	10 ns	Commercial	
GS74116AJ-12	400 mil SOJ	12 ns	Commercial	
GS74116AJ-7I	400 mil SOJ	7 ns	Industrial	
GS74116AJ-8I	400 mil SOJ	8 ns	Industrial	
GS74116AJ-10I	400 mil SOJ	10 ns	Industrial	
GS74116AJ-12I	400 mil SOJ	12 ns	Industrial	
GS74116AX-7	Fine Pitch BGA	7 ns	Commercial	
GS74116AX-8	Fine Pitch BGA	8 ns	Commercial	
GS74116AX-10	Fine Pitch BGA	10 ns	Commercial	
GS74116AX-12	Fine Pitch BGA	12 ns	Commercial	
GS74116AX-7I	Fine Pitch BGA	7 ns	Industrial	
GS74116AX-8I	Fine Pitch BGA	8 ns	Industrial	
GS74116AX-10I	Fine Pitch BGA	10 ns	Industrial	
GS74116AX-12I	Fine Pitch BGA	12 ns	Industrial	

\* Customers requiring delivery in Tape and Reel should add the character "T" to the end of the part number. For example:  
GS74116ATP-8T

**4Mb Asynchronous Datasheet Revision History**

Rev. Code: Old; New	Types of Changes Format or Content	Page #/Revisions/Reason
74116A_r1	Format/Content	• Created new datasheet
74116A_r1; 74116A_r1_01	Content	<ul style="list-style-type: none"> <li>• Added 6 ns and 7 ns speed bins</li> <li>• Updated power numbers</li> <li>• Changed FPBGA package size from 7.2 x 11.65 mm to 6 x 10 mm</li> <li>• Changed package designator from "U" to "X" for FPBGA</li> <li>• Changed D3 on FPBGA pinout to A17 and E3 to NC</li> </ul>
74116A_r1_01; 74116A_r1_02	Content	<ul style="list-style-type: none"> <li>• Updated Recommended Operating Conditions on page 4</li> <li>• Updated Read Cycle and Write Cycle AC Characteristics tables</li> </ul>
74116A_r1_02; 74116A_r1_03	Content	• Removed 6 ns speed bin from entire document