

REV	DATE	BY	CHK	DESCRIPTION	DATE	BY	CHK
DF	DO						
L				REV PER ECO-20080831	200808	PY	DM

△ UL/CSA DESIGNATION STAMPED IN THIS AREA, OPTIONAL.

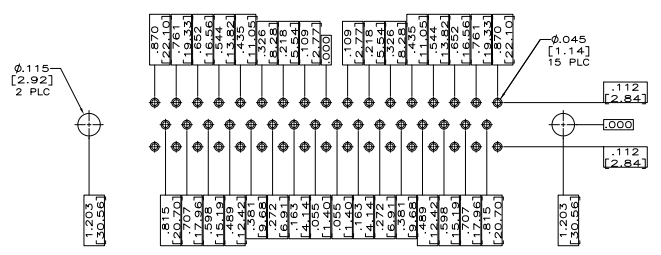

RECOMMENDED P.C. BOARD LAYOUT

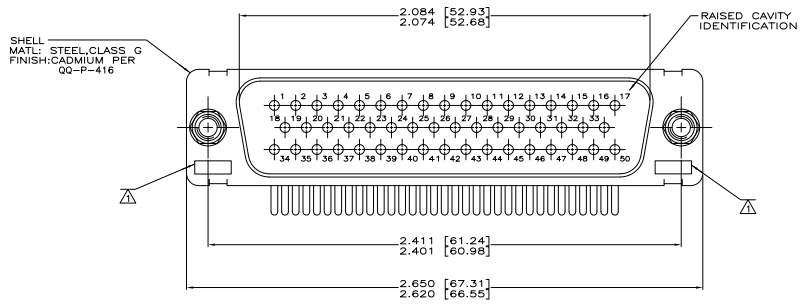
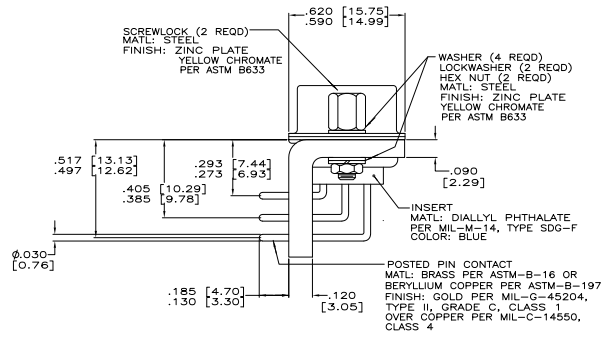
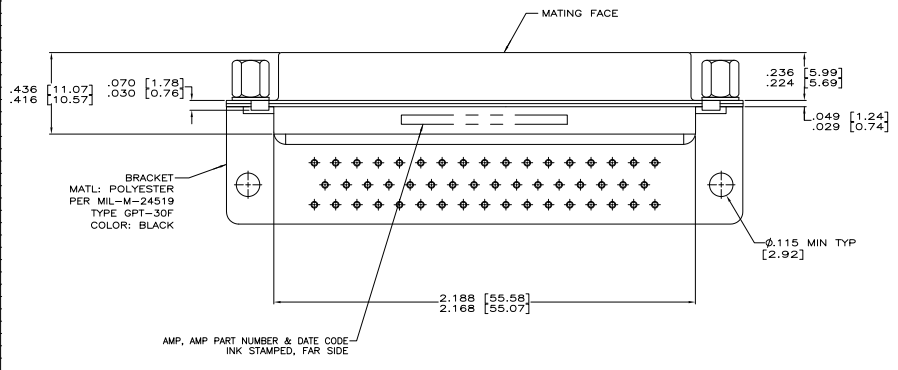

AS SHOWN	208940-1
MATERIAL	PART NO.

THIS DRAWING IS A CONTROLLED DOCUMENT.		BY: ALEXANDER	DATE: 1-13-82	APP: [Signature]	DATE: 1-13-82
DESCRIPTION:	INSTRUCTIONS:	DATE:	DATE:	DATE:	DATE:
INCHES	FRAC	DEC	DEC	DEC	DEC
1/16	1/32	1/64	1/32	1/64	1/32
1/8	1/16	1/32	1/16	1/32	1/16
3/16	1/8	1/16	1/8	1/16	1/8
1/2	3/16	1/4	3/16	1/4	3/16
3/4	1/2	3/4	1/2	3/4	1/2
1	3/4	1	3/4	1	3/4
1 1/4	1	1 1/4	1	1 1/4	1
1 1/2	1 1/4	1 1/2	1 1/4	1 1/2	1 1/4
1 3/4	1 1/2	1 3/4	1 1/2	1 3/4	1 1/2
2	1 3/4	2	1 3/4	2	1 3/4
2 1/4	2	2 1/4	2	2 1/4	2
2 1/2	2 1/4	2 1/2	2 1/4	2 1/2	2 1/4
2 3/4	2 1/2	2 3/4	2 1/2	2 3/4	2 1/2
3	2 3/4	3	2 3/4	3	2 3/4
3 1/4	3	3 1/4	3	3 1/4	3
3 1/2	3 1/4	3 1/2	3 1/4	3 1/2	3 1/4
3 3/4	3 1/2	3 3/4	3 1/2	3 3/4	3 1/2
4	3 3/4	4	3 3/4	4	3 3/4
4 1/4	4	4 1/4	4	4 1/4	4
4 1/2	4 1/4	4 1/2	4 1/4	4 1/2	4 1/4
4 3/4	4 1/2	4 3/4	4 1/2	4 3/4	4 1/2
5	4 3/4	5	4 3/4	5	4 3/4
5 1/4	5	5 1/4	5	5 1/4	5
5 1/2	5 1/4	5 1/2	5 1/4	5 1/2	5 1/4
5 3/4	5 1/2	5 3/4	5 1/2	5 3/4	5 1/2
6	5 3/4	6	5 3/4	6	5 3/4
6 1/4	6	6 1/4	6	6 1/4	6
6 1/2	6 1/4	6 1/2	6 1/4	6 1/2	6 1/4
6 3/4	6 1/2	6 3/4	6 1/2	6 3/4	6 1/2
7	6 3/4	7	6 3/4	7	6 3/4
7 1/4	7	7 1/4	7	7 1/4	7
7 1/2	7 1/4	7 1/2	7 1/4	7 1/2	7 1/4
7 3/4	7 1/2	7 3/4	7 1/2	7 3/4	7 1/2
8	7 3/4	8	7 3/4	8	7 3/4
8 1/4	8	8 1/4	8	8 1/4	8
8 1/2	8 1/4	8 1/2	8 1/4	8 1/2	8 1/4
8 3/4	8 1/2	8 3/4	8 1/2	8 3/4	8 1/2
9	8 3/4	9	8 3/4	9	8 3/4
9 1/4	9	9 1/4	9	9 1/4	9
9 1/2	9 1/4	9 1/2	9 1/4	9 1/2	9 1/4
9 3/4	9 1/2	9 3/4	9 1/2	9 3/4	9 1/2
10	9 3/4	10	9 3/4	10	9 3/4
10 1/4	10	10 1/4	10	10 1/4	10
10 1/2	10 1/4	10 1/2	10 1/4	10 1/2	10 1/4
10 3/4	10 1/2	10 3/4	10 1/2	10 3/4	10 1/2
11	10 3/4	11	10 3/4	11	10 3/4
11 1/4	11	11 1/4	11	11 1/4	11
11 1/2	11 1/4	11 1/2	11 1/4	11 1/2	11 1/4
11 3/4	11 1/2	11 3/4	11 1/2	11 3/4	11 1/2
12	11 3/4	12	11 3/4	12	11 3/4
12 1/4	12	12 1/4	12	12 1/4	12
12 1/2	12 1/4	12 1/2	12 1/4	12 1/2	12 1/4
12 3/4	12 1/2	12 3/4	12 1/2	12 3/4	12 1/2
13	12 3/4	13	12 3/4	13	12 3/4
13 1/4	13	13 1/4	13	13 1/4	13
13 1/2	13 1/4	13 1/2	13 1/4	13 1/2	13 1/4
13 3/4	13 1/2	13 3/4	13 1/2	13 3/4	13 1/2
14	13 3/4	14	13 3/4	14	13 3/4
14 1/4	14	14 1/4	14	14 1/4	14
14 1/2	14 1/4	14 1/2	14 1/4	14 1/2	14 1/4
14 3/4	14 1/2	14 3/4	14 1/2	14 3/4	14 1/2
15	14 3/4	15	14 3/4	15	14 3/4
15 1/4	15	15 1/4	15	15 1/4	15
15 1/2	15 1/4	15 1/2	15 1/4	15 1/2	15 1/4
15 3/4	15 1/2	15 3/4	15 1/2	15 3/4	15 1/2
16	15 3/4	16	15 3/4	16	15 3/4
16 1/4	16	16 1/4	16	16 1/4	16
16 1/2	16 1/4	16 1/2	16 1/4	16 1/2	16 1/4
16 3/4	16 1/2	16 3/4	16 1/2	16 3/4	16 1/2
17	16 3/4	17	16 3/4	17	16 3/4
17 1/4	17	17 1/4	17	17 1/4	17
17 1/2	17 1/4	17 1/2	17 1/4	17 1/2	17 1/4
17 3/4	17 1/2	17 3/4	17 1/2	17 3/4	17 1/2
18	17 3/4	18	17 3/4	18	17 3/4
18 1/4	18	18 1/4	18	18 1/4	18
18 1/2	18 1/4	18 1/2	18 1/4	18 1/2	18 1/4
18 3/4	18 1/2	18 3/4	18 1/2	18 3/4	18 1/2
19	18 3/4	19	18 3/4	19	18 3/4
19 1/4	19	19 1/4	19	19 1/4	19
19 1/2	19 1/4	19 1/2	19 1/4	19 1/2	19 1/4
19 3/4	19 1/2	19 3/4	19 1/2	19 3/4	19 1/2
20	19 3/4	20	19 3/4	20	19 3/4
20 1/4	20	20 1/4	20	20 1/4	20
20 1/2	20 1/4	20 1/2	20 1/4	20 1/2	20 1/4
20 3/4	20 1/2	20 3/4	20 1/2	20 3/4	20 1/2
21	20 3/4	21	20 3/4	21	20 3/4
21 1/4	21	21 1/4	21	21 1/4	21
21 1/2	21 1/4	21 1/2	21 1/4	21 1/2	21 1/4
21 3/4	21 1/2	21 3/4	21 1/2	21 3/4	21 1/2
22	21 3/4	22	21 3/4	22	21 3/4
22 1/4	22	22 1/4	22	22 1/4	22
22 1/2	22 1/4	22 1/2	22 1/4	22 1/2	22 1/4
22 3/4	22 1/2	22 3/4	22 1/2	22 3/4	22 1/2
23	22 3/4	23	22 3/4	23	22 3/4
23 1/4	23	23 1/4	23	23 1/4	23
23 1/2	23 1/4	23 1/2	23 1/4	23 1/2	23 1/4
23 3/4	23 1/2	23 3/4	23 1/2	23 3/4	23 1/2
24	23 3/4	24	23 3/4	24	23 3/4
24 1/4	24	24 1/4	24	24 1/4	24
24 1/2	24 1/4	24 1/2	24 1/4	24 1/2	24 1/4
24 3/4	24 1/2	24 3/4	24 1/2	24 3/4	24 1/2
25	24 3/4	25	24 3/4	25	24 3/4
25 1/4	25	25 1/4	25	25 1/4	25
25 1/2	25 1/4	25 1/2	25 1/4	25 1/2	25 1/4
25 3/4	25 1/2	25 3/4	25 1/2	25 3/4	25 1/2
26	25 3/4	26	25 3/4	26	25 3/4
26 1/4	26	26 1/4	26	26 1/4	26
26 1/2	26 1/4	26 1/2	26 1/4	26 1/2	26 1/4
26 3/4	26 1/2	26 3/4	26 1/2	26 3/4	26 1/2
27	26 3/4	27	26 3/4	27	26 3/4
27 1/4	27	27 1/4	27	27 1/4	27
27 1/2	27 1/4	27 1/2	27 1/4	27 1/2	27 1/4
27 3/4	27 1/2	27 3/4	27 1/2	27 3/4	27 1/2
28	27 3/4	28	27 3/4	28	27 3/4
28 1/4	28	28 1/4	28	28 1/4	28
28 1/2	28 1/4	28 1/2	28 1/4	28 1/2	28 1/4
28 3/4	28 1/2	28 3/4	28 1/2	28 3/4	28 1/2
29	28 3/4	29	28 3/4	29	28 3/4
29 1/4	29	29 1/4	29	29 1/4	29
29 1/2	29 1/4	29 1/2	29 1/4	29 1/2	29 1/4
29 3/4	29 1/2	29 3/4	29 1/2	29 3/4	29 1/2
30	29 3/4	30	29 3/4	30	29 3/4
30 1/4	30	30 1/4	30	30 1/4	30
30 1/2	30 1/4	30 1/2	30 1/4	30 1/2	30 1/4
30 3/4	30 1/2	30 3/4	30 1/2	30 3/4	30 1/2
31	30 3/4	31	30 3/4	31	30 3/4
31 1/4	31	31 1/4	31	31 1/4	31
31 1/2	31 1/4	31 1/2	31 1/4	31 1/2	31 1/4
31 3/4	31 1/2	31 3/4	31 1/2	31 3/4	31 1/2
32	31 3/4	32	31 3/4	32	31 3/4
32 1/4	32	32 1/4	32	32 1/4	32
32 1/2	32 1/4	32 1/2	32 1/4	32 1/2	32 1/4
32 3/4	32 1/2	32 3/4	32 1/2	32 3/4	32 1/2
33	32 3/4	33	32 3/4	33	32 3/4
33 1/4	33	33 1/4	33	33 1/4	33
33 1/2	33 1/4	33 1/2	33 1/4	33 1/2	33 1/4
33 3/4	33 1/2	33 3/4	33 1/2	33 3/4	33 1/2
34	33 3/4	34	33 3/4	34	33 3/4
34 1/4	34	34 1/4	34	34 1/4	34
34 1/2	34 1/4	34 1/2	34 1/4	34 1/2	34 1/4
34 3/4	34 1/2	34 3/4	34 1/2	34 3/4	34 1/2
35	34 3/4	35	34 3/4	35	34 3/4
35 1/4	35	35 1/4	35	35 1/4	35
35 1/2	35 1/4	35 1/2	35 1/4	35 1/2	35 1/4
35 3/4	35 1/2	35 3/4	35 1/2	35 3/4	35 1/2
36	35 3/4	36	35 3/4	36	35 3/4
36 1/4	36	36 1/4	36	36 1/4	36
36 1/2	36 1/4	36 1/2	36 1/4	36 1/2	36 1/4
36 3/4	36 1/2	36 3/4	36 1/2	36 3/4	36 1/2
37	36 3/4	37	36 3/4	37	36 3/4
37 1/4	37	37 1/4	37	37 1/4	37
37 1/2	37 1/4	37 1/2	37 1/4	37 1/	