

UL/CSA DESIGNATION STAMPED IN THIS AREA, OPTIONAL.

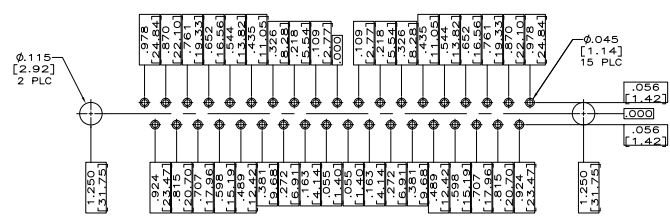

RECOMMENDED P.C. BOARD LAYOUT

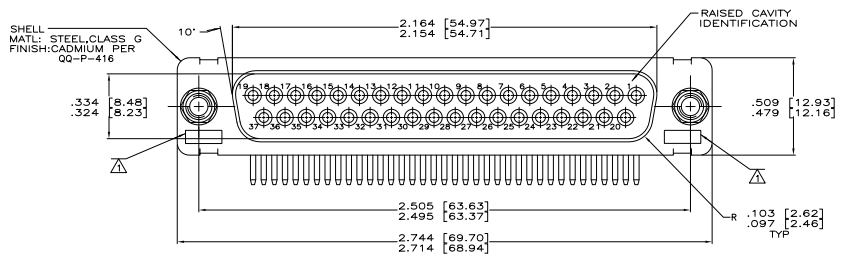
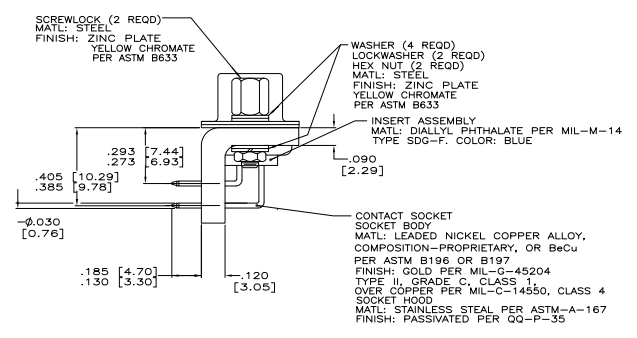
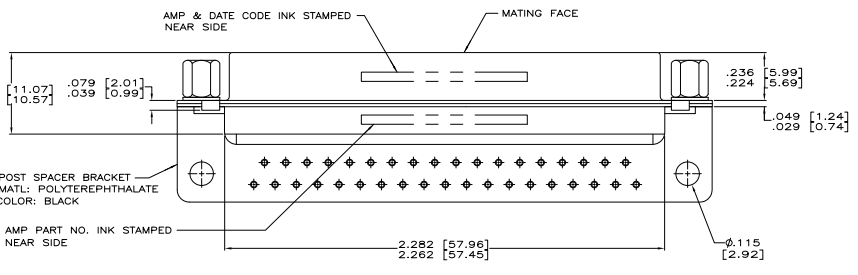

THIS DRAWING IS A CONTROLLED DOCUMENT.		BY: ALEXANDER 1-18-82	DATE: 1-18-82	AS SHOWN	208939-1
CHECKED: [Signature]		BY: EMAGI 1-18-82	DATE: 1-18-82	DESCRIPTION	PART NO.
DESIGNED: [Signature]		MATERIALS: [Signature]		RECEPTACLE, SIZE 4, 37 POSITION HDW POSTED 90 DEGREE, WITH SCREWLOCKS	
DRAWN: [Signature]		SPECIFICATION SPEC: [Signature]		SIZE: [Signature]	
SEE CALLOUTS		REV: [Signature]		REVISED TO: [Signature]	
		CUSTOMER DRAWING		A1 00779 (C)=208939	