

REV	DATE	DESCRIPTION	BY	CHK	APP
1					
2					
3					
4					
5					
6					
7					
8					

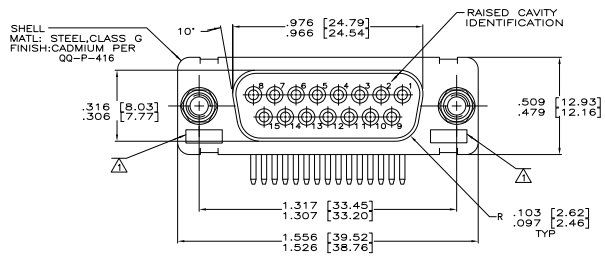

△ UL/CSA DESIGNATION STAMPED IN THIS AREA, OPTIONAL.

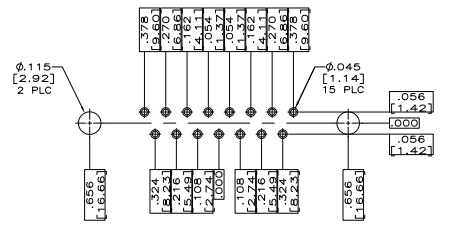

RECOMMENDED P.C. BOARD LAYOUT

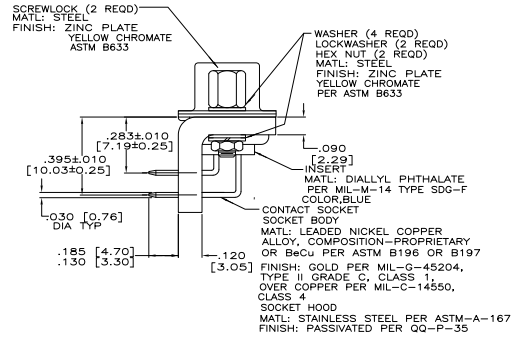
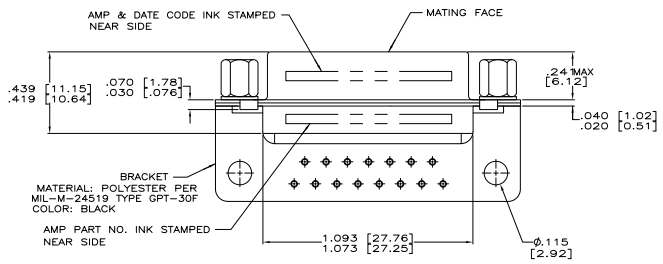

AS SHOWN	208395-1
DESCRIPTION	PART NO.

THIS DRAWING IS A CONTROLLED DOCUMENT.		BY: ALEXANDER 12-31-11	DATE: 12-31-11
DESIGNER:	APPROVED:	DATE:	DATE:
WORKS:	APPROVED:	DATE:	DATE:
ISSUED:	APPROVED:	DATE:	DATE:
REVISED:	APPROVED:	DATE:	DATE:
SEE CALLOUTS	SEE CALLOUTS	CUSTOMER DRAWING	DATE: 4-11-11

TYSO Electronics  
 Tyco Electronics Corporation  
 Harrisburg, PA 17105-3608

RECEPTACLE, SIZE 2, 15 POSITION  
 DDM, POSTED 90 DEGREES WITH SCREWLOCKS

SIZE: 100779 (G)=208395