

4

3

2

1

THIS DRAWING IS UNPUBLISHED. RELEASED FOR PUBLICATION  
 © COPYRIGHT BY TYCO ELECTRONICS CORPORATION. ALL RIGHTS RESERVED.

LOC		DIB		REVISIONS		
P	LTR	DESCRIPTION	DATE	BY	APPD	
N		REV PER ECO-08-000831	26FEB08	PY	DM	

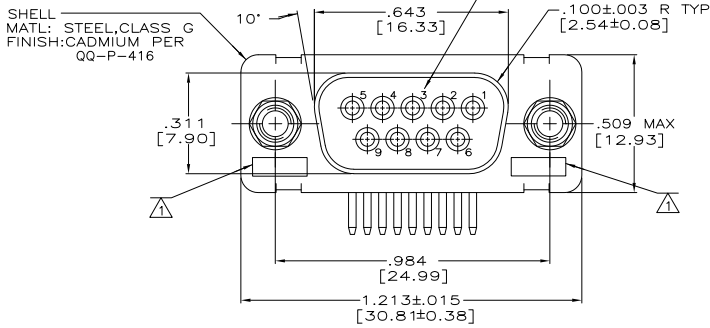

UL/CSA DESIGNATION STAMPED IN THIS AREA, OPTIONAL

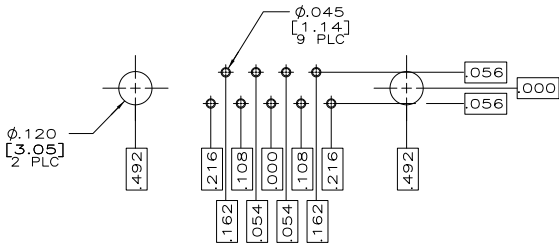
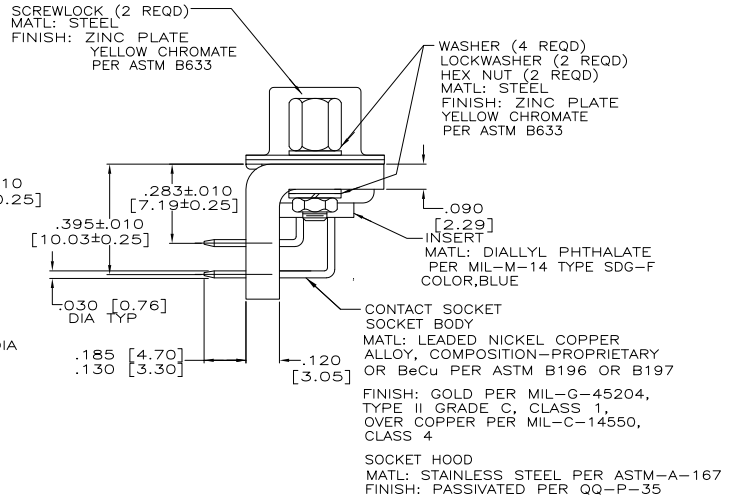
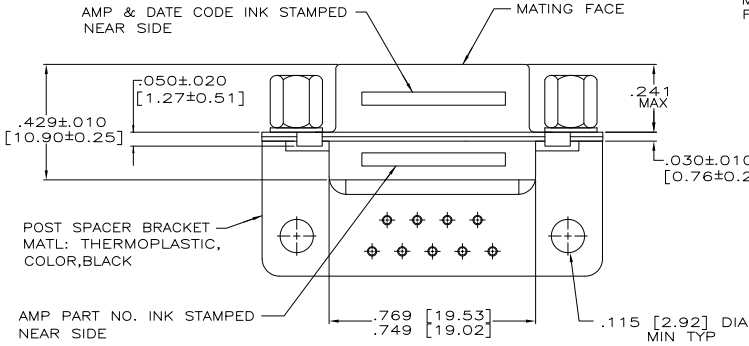

RECOMMENDED P.C. BOARD LAYOUT

THIS DRAWING IS A CONTROLLED DOCUMENT.		7-31-91		AS SHOWN		208933-1	
DIMENSIONS: INCHES		P. YEAGER		Tyco Electronics Corporation		Harrisburg, PA 17105-3608	
OTHER DIMENSIONS: MILLIMETERS		OK		EMAD		RECEPTACLE, SIZE 1, 9 POSN HDM POSTED 90° WITH SCREWLOCKS	
FINISH		A. EMADI		PRODUCT SPEC		SIZE CASE CODE DRAWING NO RESTRICTED TO	
MATERIAL		APPLICATION SPEC		WEIGHT		A2 00779 C-208933	
SEE CALLOUTS		SEE CALLOUTS		CUSTOMER DRAWING		SCALE 4:1 SHEET 1 of 1 REV N	

AMP 1471-9 REV 31MM2000

208933

A