

REV	DATE	DESCRIPTION	BY	CHK	APP
1					
2					
3					
4					
5					
6					
7					
8					

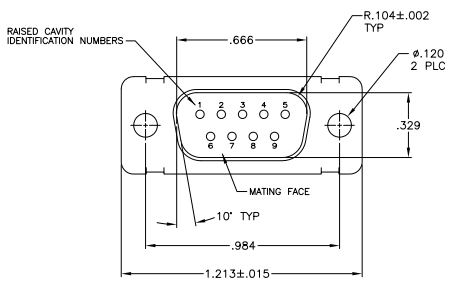

- 1 THIS PLUG IS DESIGNED TO CONFORM TO THE LATEST ISSUE OF MIL-C-24308.
- 2. MAX WIRE INSULATION TO BE USED WITH THIS PLUG IS .072 DIA.
- 3. METAL RETENTION CLIPS ARE INCLUDED IN INSERTS.
- 4. THIS PLUG WILL ACCEPT SIZE 20 CRIMP TYPE PIN CONTACT M 39029/54-369 (TE CONNECTIVITY P/N 205089-1) FOR ALTERNATE CONTACT OPTIONS CONSULT TE CONNECTIVITY CATALOG.
- 5 PART NO. 205162-4, 205162-5 & 5-205162-4 HAS GROUNDING INDENTS ON FRONT SHELL. (NOT SHOWN)
- 6 FINISH: CADMIUM PER QQ-P-416, TYPE II, CLASS 2 OVER COPPER PER AMS2418, CLASS 4.
- 8 THIS NOTE APPLIES TO 205162-1 ONLY. M24308/4-1 F MARKED ON FAR SIDE. 205556-2 MARKED ON NEAR SIDE. MFG'S PART NO. & MILITARY PART NO. MARKED ON CONNECTOR REPRESENTS KIT NUMBER WITH CONTACTS PACKAGE STAMPED M 24308/4-259F
- 9 CONTACTS ARE NOT INCLUDED IN THIS ASSEMBLY. MUST BE ORDERED SEPARATELY.
- 10 FINISH: BRIGHT TIN .000400-.00050 THK PER ASTM-B-545 OVER COPPER .000500 MIN THK PER AMS2418.

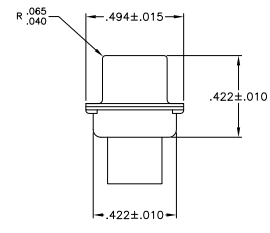
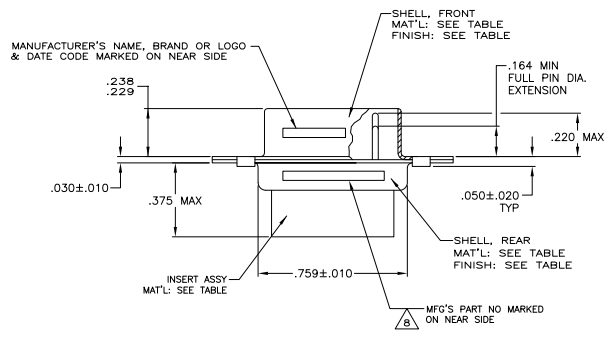

REMARKS	SHELL FINISH	SHELL MATERIAL	INSERT MAT'L	PART NUMBER
	5, 11	10	STEEL PER ASTM-A-109 OR EQUIVALENT	POLYESTER PER MIL-M-24519, TYPE GET-30F
	9	10	STEEL PER ASTM-A-109 OR EQUIVALENT	POLYESTER PER MIL-M-24519, TYPE GET-30F
	5, 9	10	STEEL PER ASTM-A-109 OR EQUIVALENT	POLYESTER PER MIL-M-24519, TYPE GET-30F
	5, 9	10	STEEL PER ASTM-A-109 OR EQUIVALENT	POLYESTER PER MIL-M-24519, TYPE GET-30F
SUPSD BY 206288-1	9	6	STEEL PER ASTM-A-109 OR EQUIVALENT	POLYESTER PER MIL-M-24519, TYPE GET-30F
SUPSD BY 207252-2		6	STEEL PER ASTM-A-109 OR EQUIVALENT	POLYESTER PER MIL-M-24519, TYPE GET-30F
	11, 9	6	STEEL PER ASTM-A-109 OR EQUIVALENT	POLYESTER PER MIL-M-24519, TYPE GET-30F

THIS DRAWING IS A CONTROLLED DOCUMENT. DATE: 3-2-88

DESIGNED BY: J. MILLER DATE: 3-2-88

DRAWN BY: J. MILLER DATE: 3-2-88

CHECKED BY: J. MILLER DATE: 3-2-88

APPROVED BY: J. MILLER DATE: 3-2-88

TE Connectivity
 PLUG ASSY/AMPLITE, 9 POSN
 SIZE 1, SERIES 109

MIL-C-24308

I.S. 7516 & 7518

DATE USE: 10/07/79 DRAWING NO: 100779 Q=205162

CUSTOMER DRAWING

SIZE: 4.1 SHEET: 1 OF 1