

REVISONS		DATE	BY	APP
DF	DO			

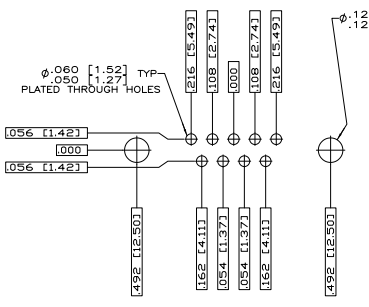

RECOMMENDED P.C. BOARD LAYOUT
 SHELL SIZE 1 (9 POSITION) Δ

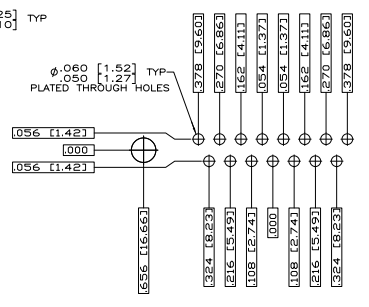

RECOMMENDED P.C. BOARD LAYOUT
 SHELL SIZE 2 (15 POSITION) Δ

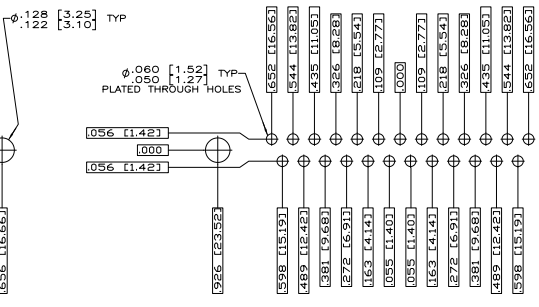

RECOMMENDED P.C. BOARD LAYOUT
 SHELL SIZE 3 (25 POSITION) Δ

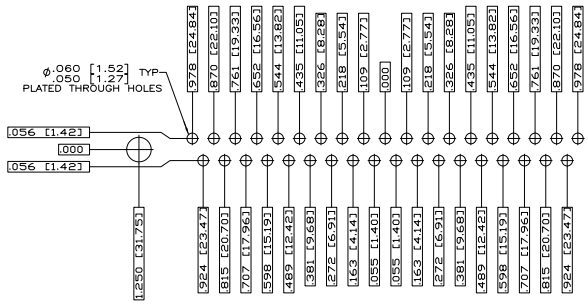

RECOMMENDED P.C. BOARD LAYOUT
 SHELL SIZE 4 (37 POSITION) Δ

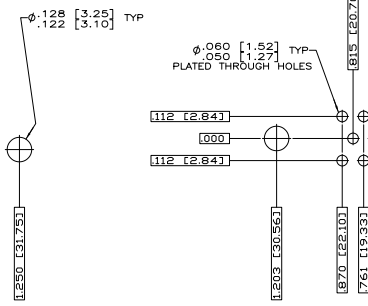

RECOMMENDED P.C. BOARD LAYOUT
 SHELL SIZE 5 (50 POSITION) Δ

THIS DRAWING IS A CONTROLLED DOCUMENT.		TYS ELECTRONICS CORPORATION HARRISBURG, PA 17105-3608 RECEIPTABLE ASSEMBLY/AMPLIFIER POSTED/SERIES 109/SIZE 1 THRU 5	
DESIGNED BY: [blank] DRAWN BY: [blank] CHECKED BY: [blank] DATE: [blank]	APPROVED BY: [blank] DATE: [blank]	PART NO: 100-000-0000 REV: A CUSTOMER DRAWING: 100779G-1757834	SHEET: 41 OF: 2 REV: B