

RECOMMENDED P.C. BOARD LAYOUT  
 SHELL SIZE 1 (9 POSITION)  $\Delta$

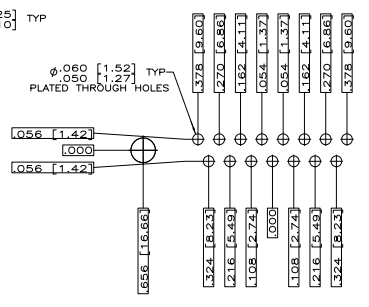

RECOMMENDED P.C. BOARD LAYOUT  
 SHELL SIZE 2 (15 POSITION)  $\Delta$

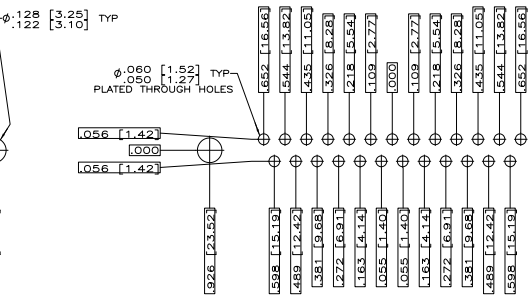

RECOMMENDED P.C. BOARD LAYOUT  
 SHELL SIZE 3 (25 POSITION)  $\Delta$

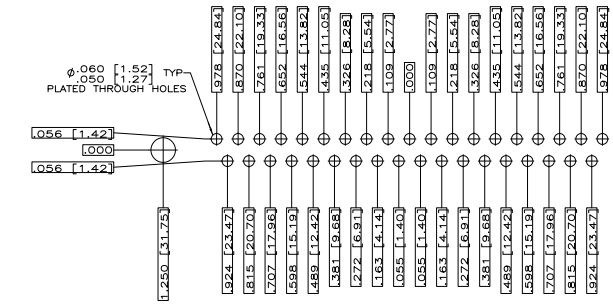

RECOMMENDED P.C. BOARD LAYOUT  
 SHELL SIZE 4 (37 POSITION)  $\Delta$

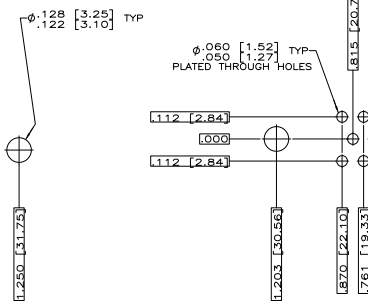

RECOMMENDED P.C. BOARD LAYOUT  
 SHELL SIZE 5 (50 POSITION)  $\Delta$

THIS DRAWING IS A CONTROLLED DOCUMENT.		DATE: 12-14-98	
DRAWN BY: J. THOMAS		DATE: 12-15-98	
CHECKED BY: J. THOMAS		DATE: 12-15-98	
APPROVED BY: J. THOMAS		DATE: 12-15-98	
CUSTOMER DRAWING		DRAWING NO: 100779	
REV: 4.1		SHEET: 2	