

REV	DATE	DESCRIPTION	BY	CHK	APP
A	REV PER EC 0414-0277-06				

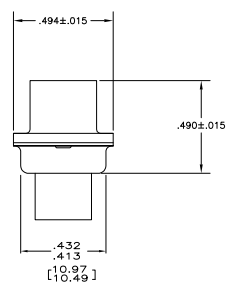
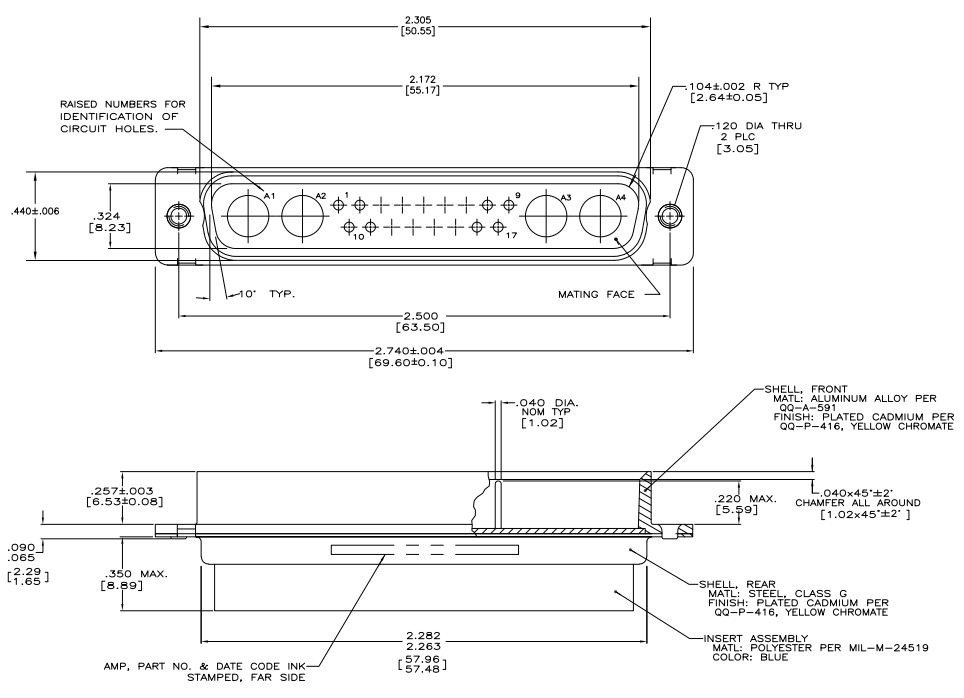

1. THIS PLUG WILL MATE WITH ANY 21C4, SIZE 4 RECEPTACLE IN AMPLIMITE SERIES.
3. SST RETENTION CLIPS ARE INCLUDED IN INSERTS AT POSITIONS 1 THRU 17
4. THIS PLUG IS DESIGNED TO CONFORM TO THE LATEST ISSUE OF MIL-C-24308.
5. CONNECTOR SUPPLIED WITHOUT CONTACTS; SHOWN FOR ILLUSTRATION ONLY.
6. POSITIONS 1 THRU 17 WILL ACCEPT SIZE 20 DM PIN CONTACT M39029/64-369 OR ANY AMP SIZE 20 DF PIN CONTACT

THIS DRAWING IS A CONTROLLED DOCUMENT.		DATE	REV	DESCRIPTION	BY	CHK	APP
DATE	REV	DESCRIPTION	BY	CHK	APP		

447728-1
PART NO

THIS DRAWING IS A CONTROLLED DOCUMENT. DATE: 2/18/81. REV: 1. DESCRIPTION: PLUG ASSEMBLY, AMPLIMITE, CDKX MK, 21C4, SIZE 4, SERIES 109, BLK/WHITE. DRAWING NO: 447728. REVISED TO: ---. CUSTOMER DRAWING: ---. SIZE: ---. SHEET: 1 OF 1. REV: A.