

| REV | DATE | DESCRIPTION | BY | CHK |
|-----|------|---------------------------|----|-----|
| 01 | | REVISED PER EDD-11-005030 | | |

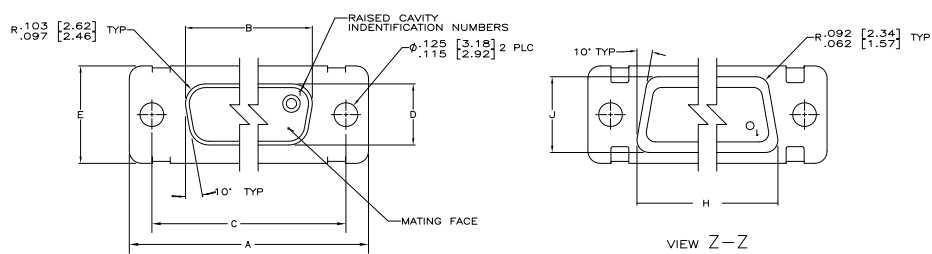

- △ SEE SHEET 2 FOR RECOMMENDED P.C. BOARD LAYOUT. TRUE POSITION TOLERANCE FOR P.C. BOARD LAYOUT IS .010 [0.25] AT MAX MATERIAL CONDITION. SUGGESTED BOARD THICKNESS IS .125 [3.18]
- 2. THE CONNECTORS DESCRIBED IN THIS DOCUMENT MEET THE REQUIREMENTS OF MIL-C-24308 AND MATE WITH ANY PLUG CONNECTOR WITH SAME INSERT ARRANGEMENT.
- △ MARK WITH .047 [1.19]-.062 [1.57] HIGH CHARACTERS. FAR SIDE REFERS TO THE WIDE SIDE OF THE KEYSTONE. NEAR SIDE REFERS TO THE NARROW SIDE OF THE KEYSTONE. IF THE REAR SHELL IS TOO SMALL FOR THE ENTIRE MILITARY PART NUMBER, MARKING SHALL BE LOCATED AS FOLLOWS:
 - A. "M24308" ON FRONT SHELL, FAR SIDE.
 - B. SLASH SHEET AND DASH NUMBER ON REAR SHELL, FAR SIDE.
 - C. "AMP" AND DATE CODE ON FRONT SHELL, NEAR SIDE.
 - D. PART NUMBER ON REAR SHELL, NEAR SIDE.
- IF THE FRONT SHELL IS TOO SMALL FOR "AMP", PART NUMBER AND DATE CODE, THEN SPLIT AS FOLLOWS:
 - A. PART NUMBER ON REAR SHELL, NEAR SIDE.
 - B. "AMP" AND DATE CODE ON FRONT SHELL, NEAR SIDE.
 - C. MILITARY PART NUMBER ON REAR SHELL, FAR SIDE.
- △ POINT OF ELECTRICAL ENGAGEMENT - AS MEASURED WITH A .0390 [0.991]-.0393 [0.998] DIA SQUARE ENDED TEST PIN.
- △ SOLDER DIP PER MIL-STD-2000 COMPOSITION Sn63 CONFORMING TO QQ-S-571. COVERAGE SHALL BE COMPLETE TO A DISTANCE .020 [0.51] MAX FROM INSERT ASSEMBLY.
- 6. THE SOLDER DIP PROCESS IS PERFORMED SUBSEQUENT TO THE COMPLETION OF PRODUCTION OF THE MILITARY QUALIFIED CONNECTOR. DIMENSIONS APPLY PRIOR TO SOLDER DIPPING.
- △ SPACERS (QTY 2) ARE SUPPLIED WITH CONNECTORS (NOT ATTACHED TO THE CONNECTOR).
- 8. DIMENSIONS AND TOLERANCES PER ANSI Y14.5M-1982.
- 9. THIS DRAWING SHALL BE INTERPRETED IN ACCORDANCE WITH APPLICABLE STANDARDS LISTED IN MIL-STD-100.

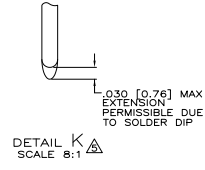
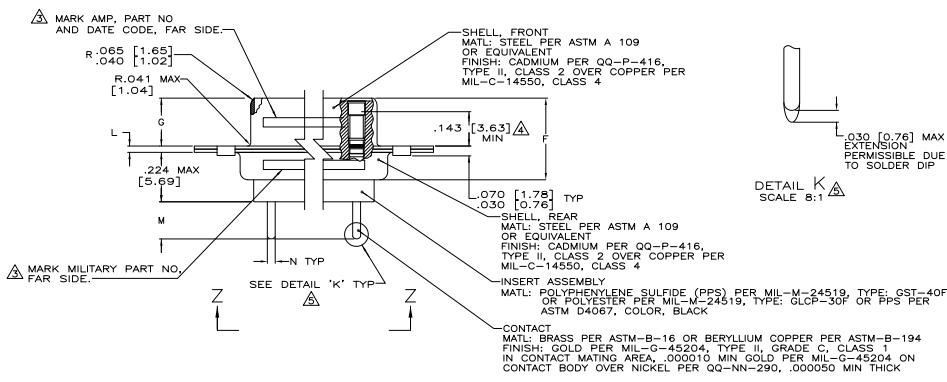

| | | | | | | | | | | | | | |
|--|--------------|---------------|--------------|--------------|---------------|---------------|---------------|-----------|----|---|--------------|----------|------------|
| | .544 [13.82] | 2.188 [55.58] | .620 [15.75] | .428 [10.87] | 2.411 [61.24] | 2.069 [52.55] | 2.650 [67.31] | MS18277-1 | 50 | 5 | M24308/23-5F | 443975-5 | 1-443975-0 |
| | .524 [13.31] | 2.188 [55.07] | .590 [14.99] | .418 [10.66] | 2.401 [60.99] | 2.059 [52.30] | 2.650 [66.55] | MS18276-1 | 37 | 4 | M24308/23-4F | 443975-4 | 443975-9 |
| | | 2.282 [57.96] | | | 2.505 [63.63] | 2.164 [54.97] | 2.744 [69.70] | MS18275-1 | 25 | 3 | M24308/23-3F | 443975-3 | 443975-8 |
| | | 2.262 [57.45] | | | 2.485 [63.37] | 2.154 [54.71] | 2.714 [68.94] | MS18274-1 | 15 | 2 | M24308/23-2F | 443975-2 | 443975-7 |
| | .432 [10.97] | 1.615 [41.02] | .508 [12.93] | .316 [8.03] | 1.847 [46.91] | 1.506 [38.25] | 2.073 [52.65] | MS18273-1 | 9 | 1 | M24308/23-1F | 443975-1 | 443975-6 |
| | .412 [10.46] | 1.093 [27.76] | .478 [12.17] | .306 [7.77] | 1.317 [33.45] | .976 [24.79] | 1.556 [39.52] | MS18272-1 | 50 | 5 | M24308/23-5F | 443975-5 | 443975-5 |
| | | 1.073 [27.25] | | | 1.307 [33.20] | .966 [24.54] | 1.526 [38.76] | MS18271-1 | 37 | 4 | M24308/23-4F | 443975-4 | 443975-4 |
| | | .769 [19.53] | | | .989 [25.12] | .648 [16.46] | 1.228 [31.19] | MS18270-1 | 25 | 3 | M24308/23-3F | 443975-3 | 443975-3 |
| | | .749 [19.02] | .248 [6.30] | .439 [11.15] | .979 [24.87] | .638 [16.21] | 1.198 [30.43] | MS18269-1 | 15 | 2 | M24308/23-2F | 443975-2 | 443975-2 |
| | .544 [13.82] | 2.188 [55.58] | .620 [15.75] | .428 [10.87] | 2.411 [61.24] | 2.069 [52.55] | 2.650 [67.31] | MS18277-1 | 50 | 5 | M24308/23-5F | 443975-5 | 443975-5 |
| | .524 [13.31] | 2.188 [55.07] | .590 [14.99] | .418 [10.66] | 2.401 [60.99] | 2.059 [52.30] | 2.650 [66.55] | MS18276-1 | 37 | 4 | M24308/23-4F | 443975-4 | 443975-4 |
| | | 2.282 [57.96] | | | 2.505 [63.63] | 2.164 [54.97] | 2.744 [69.70] | MS18275-1 | 25 | 3 | M24308/23-3F | 443975-3 | 443975-3 |
| | | 2.262 [57.45] | | | 2.485 [63.37] | 2.154 [54.71] | 2.714 [68.94] | MS18274-1 | 15 | 2 | M24308/23-2F | 443975-2 | 443975-2 |
| | .432 [10.97] | 1.615 [41.02] | .508 [12.93] | .316 [8.03] | 1.847 [46.91] | 1.506 [38.25] | 2.073 [52.65] | MS18273-1 | 9 | 1 | M24308/23-1F | 443975-1 | 443975-1 |
| | .412 [10.46] | 1.093 [27.76] | .478 [12.17] | .306 [7.77] | 1.317 [33.45] | .976 [24.79] | 1.556 [39.52] | MS18272-1 | 50 | 5 | M24308/23-5F | 443975-5 | 443975-5 |
| | | 1.073 [27.25] | | | 1.307 [33.20] | .966 [24.54] | 1.526 [38.76] | MS18271-1 | 37 | 4 | M24308/23-4F | 443975-4 | 443975-4 |
| | | .769 [19.53] | | | .989 [25.12] | .648 [16.46] | 1.228 [31.19] | MS18270-1 | 25 | 3 | M24308/23-3F | 443975-3 | 443975-3 |
| | | .749 [19.02] | .248 [6.30] | .439 [11.15] | .979 [24.87] | .638 [16.21] | 1.198 [30.43] | MS18269-1 | 15 | 2 | M24308/23-2F | 443975-2 | 443975-2 |

| NO OF POS | SHELL SIZE | MILITARY P/N ON CONNECTOR | P/N ON CONNECTOR | PART NUMBER |
|-----------|------------|---------------------------|------------------|-------------|
| 50 | 5 | M24308/23-5F | 443975-5 | 1-443975-0 |
| 37 | 4 | M24308/23-4F | 443975-4 | 443975-9 |
| 25 | 3 | M24308/23-3F | 443975-3 | 443975-8 |
| 15 | 2 | M24308/23-2F | 443975-2 | 443975-7 |
| 9 | 1 | M24308/23-1F | 443975-1 | 443975-6 |
| 50 | 5 | M24308/23-5F | 443975-5 | 443975-5 |
| 37 | 4 | M24308/23-4F | 443975-4 | 443975-4 |
| 25 | 3 | M24308/23-3F | 443975-3 | 443975-3 |
| 15 | 2 | M24308/23-2F | 443975-2 | 443975-2 |
| 9 | 1 | M24308/23-1F | 443975-1 | 443975-1 |

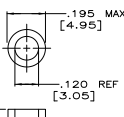

246±.003 [6.25±0.08] SPACER MATL: ALUMINUM ALLOY PER ASTM B 211 FINISH: IRIDITE PER MIL-C-5541, CLASS 3, COLOR GOLD

| REV | DF | DO | DESCRIPTION | DATE | BY | APP |
|-----|----|----|-------------|------|----|-----|
| - | - | - | SEE SHEET 1 | - | - | - |

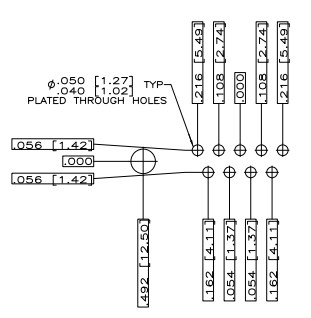

RECOMMENDED P.C. BOARD LAYOUT
 SHELL SIZE 1 (9 POSITION)

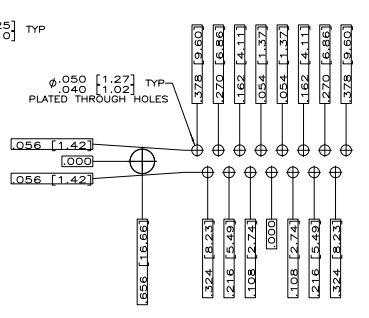

RECOMMENDED P.C. BOARD LAYOUT
 SHELL SIZE 2 (15 POSITION)

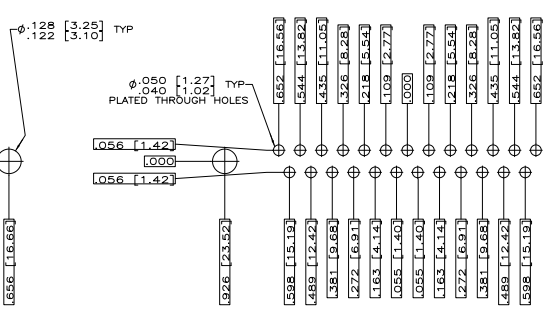

RECOMMENDED P.C. BOARD LAYOUT
 SHELL SIZE 3 (25 POSITION)

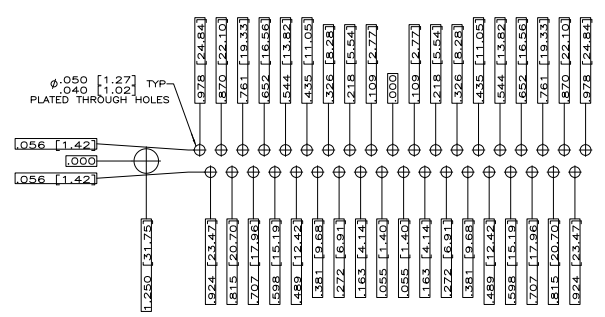

RECOMMENDED P.C. BOARD LAYOUT
 SHELL SIZE 4 (37 POSITION)

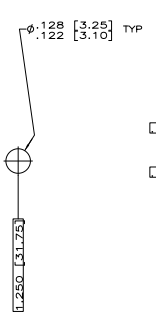

RECOMMENDED P.C. BOARD LAYOUT
 SHELL SIZE 5 (50 POSITION)

| | | | | | |
|--|---------|----------------------------------|---------|----------|---------------|
| THIS DRAWING IS A CONTROLLED DOCUMENT. | | DATE | REVISED | BY | APP |
| DATE | REVISED | BY | APP | DATE | REVISED |
| PROJECT NAME | | MIL-C-24308 | | | |
| PROJECT NO. | | P.C. BOARD CONTACTS, SERIES 109, | | | |
| CUSTOMER DRAWING | | SIZE | DATE | BY | APP |
| SEE CALLOUTS | | A1 | 00779 | G=443975 | RESTRICTED TO |
| SEE CALLOUTS | | SHEET | 4 | OF | 2 |
| SEE CALLOUTS | | DATE | 2 | BY | D1 |