

REV	DATE	DESCRIPTION	BY	CHK	APP
DF	DO				
E		REVISED PER ECO-08-013174			31-01-08 CT RL

1. STAINLESS STEEL RETENTION CLIPS ARE INCLUDED IN INSERTS AT POSITIONS 1 THRU 15
2. POSITIONS 1 THRU 15 WILL ACCEPT SIZE 20 SOCKET CONTACT M39029/63-368 OR AMP PART NO 205090-1
3. UL/CSA DESIGNATION STAMPED IN THIS AREA, OPTIONAL
4. CONTACTS NOT SUPPLIED WITH CONNECTOR

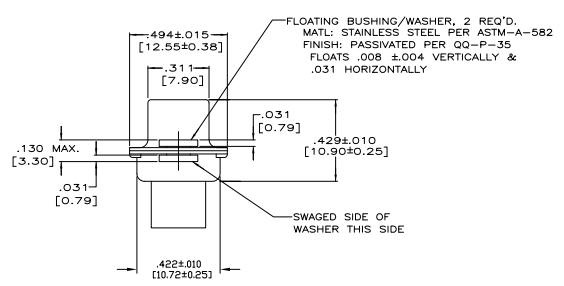
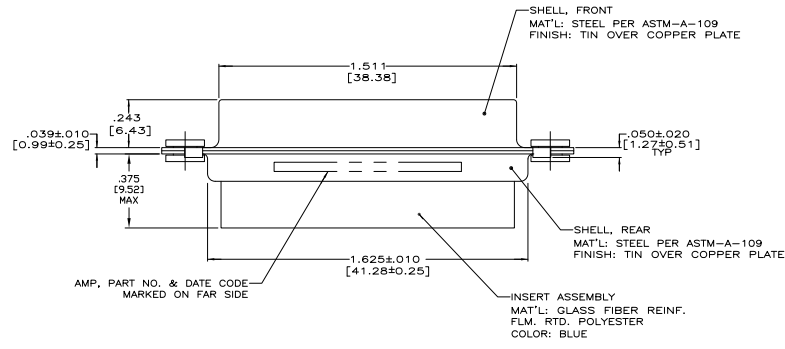
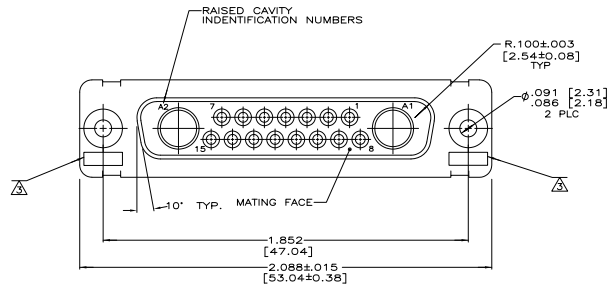

1663036-1  
PART NO.

THIS DRAWING IS A CONTROLLED DOCUMENT.		C. THOMAS		TERRY	
DESIGNED BY		D. MILLER		DATE	
CHECKED BY		D. MILLER		DATE	
DRAWN BY		D. MILLER		DATE	
APPROVED BY		D. MILLER		DATE	
CUSTOMER DRAWING		A1		00779	
SEE CALLOUTS		SEE CALLOUTS		SEE CALLOUTS	
CUSTOMER DRAWING		A1		00779	
DATE		08-01-08		DRAWN BY	
BY		D. MILLER		DATE	
CHECKED BY		D. MILLER		DATE	
DRAWN BY		D. MILLER		DATE	
APPROVED BY		D. MILLER		DATE	
CUSTOMER DRAWING		A1		00779	