

REVOLUTIONS		DATE	BY	CHK
A	RELEASED	09.10.2010	YS	JK
AI	REVISED (ECR-05-00337)	15.02.06	YS	JK
B	REVISED (ECR-07-01548)	24.02.07	SV	JK
C	REVISED (ECR-09-00395)	24.04.09	YH	HG
D	REVISED (ECR-09-00563)	23.04.09	YH	HG

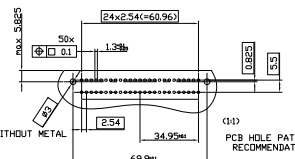
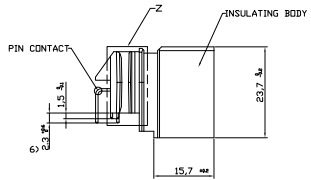
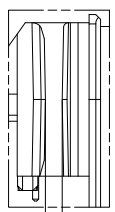
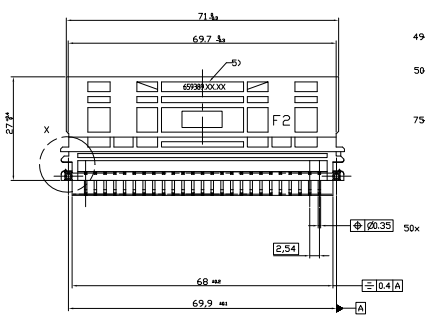
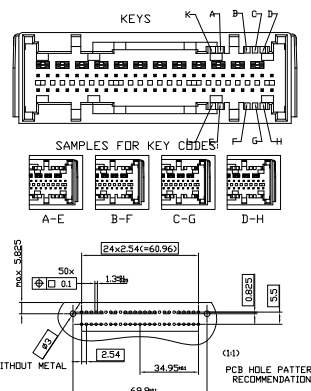
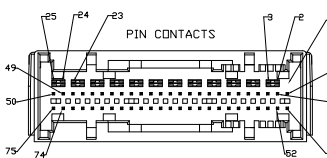

MATERIAL
 INSULATING BODY
 PBT GF 50
 RECYCLE MATERIAL MAX 25%
 COLOR: SEE TABLE

PIN CONTACT: 6x1 □
 LOCK 90 Degree
 FINISH:
 MATING AREA: 1.8MM Au OVER 12MM Pd-Ni
 SOLDERING AREA: 2.1MM Sn OVER 12MM Pd-Ni
 PUSH-OUT FORCE: IN DIRECTION OF CONNECTION
 $25N$ WITH $V.15$ PITCH IN AFTER SOLDERING
 STRAIN: LEAD 45%
 SA: AT ONE PIN, WHEN AT ALL OTHER PINS IN FLOWS
 INITIAL RESISTANCE: 20 OHM

130 DATE CODE INSULATING BODY
 132 TOLERANCE: VALID UP TO 7MM OVER BOTTOM OTHERWISE -61, +62
 133 MEASUREMENT POINTS FOR REFERENCES D AND E
 134 MEASUREMENT AT BOTTOM POINT F3
 135 MEASUREMENT AT PIN TOP 7MM ABOVE BOTTOM
 136 MEASUREMENT POINTS FOR REFERENCES B AND C
 137 MATING AREA MIN. 3L
 138 SOLDERING AREA UP TO BONDING EDGE 0MM
 139 PART NO. SIEMENS AT
 140 CAVITY SYMBOL
 141 PART NO. FOR ASSY
 142 MANUFACTURER LOGO SCRIPT HEIGHT 1.5 MM
 143 MATERIAL SYMBOL

-ALL KEYS POSSIBLE WITH INSERTS
 -40 KEYS WITH ENGAGEMENT FORCE $=50$ N
 -CABLE OUTLET LEFT AND RIGHT
 -NO FREE METAL PARTS PRESENT
 -CONNECTOR FREE OF CADMIUM -30PPM
 -STABILITY OF THE CONNECTOR SYSTEM
 100N TENSILE FORCE OF THE WIRING HARNESS AND
 10N PRESSURE FORCE OF THE FEMALE CONNECTOR
 IN EACH DIRECTION

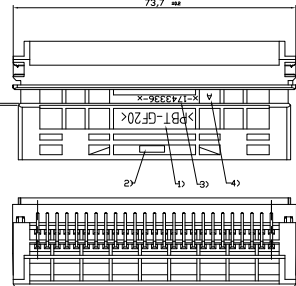
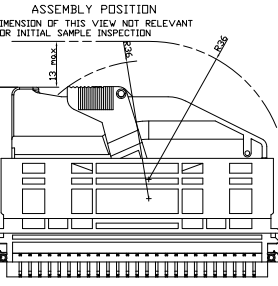
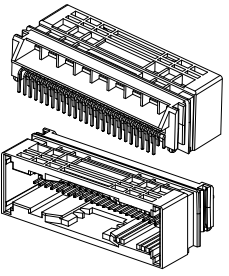
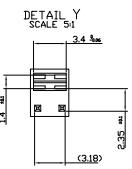
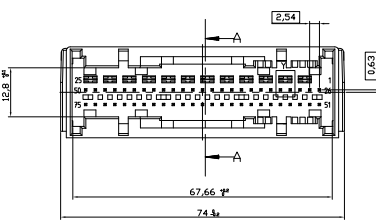
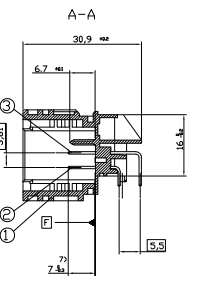
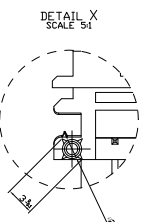

SHERINGHAM		AMP KOREA, Kyungsan, Korea	
DATE	REV	DATE	REV
01.10.09	1	01.10.09	1
02.10.09	2	02.10.09	2
03.10.09	3	03.10.09	3
04.10.09	4	04.10.09	4
05.10.09	5	05.10.09	5
06.10.09	6	06.10.09	6
07.10.09	7	07.10.09	7
08.10.09	8	08.10.09	8
09.10.09	9	09.10.09	9
10.10.09	10	10.10.09	10
11.10.09	11	11.10.09	11
12.10.09	12	12.10.09	12
13.10.09	13	13.10.09	13
14.10.09	14	14.10.09	14
15.10.09	15	15.10.09	15
16.10.09	16	16.10.09	16
17.10.09	17	17.10.09	17
18.10.09	18	18.10.09	18
19.10.09	19	19.10.09	19
20.10.09	20	20.10.09	20
21.10.09	21	21.10.09	21
22.10.09	22	22.10.09	22
23.10.09	23	23.10.09	23
24.10.09	24	24.10.09	24
25.10.09	25	25.10.09	25
26.10.09	26	26.10.09	26
27.10.09	27	27.10.09	27
28.10.09	28	28.10.09	28
29.10.09	29	29.10.09	29
30.10.09	30	30.10.09	30
31.10.09	31	31.10.09	31
32.10.09	32	32.10.09	32
33.10.09	33	33.10.09	33
34.10.09	34	34.10.09	34
35.10.09	35	35.10.09	35
36.10.09	36	36.10.09	36
37.10.09	37	37.10.09	37
38.10.09	38	38.10.09	38
39.10.09	39	39.10.09	39
40.10.09	40	40.10.09	40
41.10.09	41	41.10.09	41
42.10.09	42	42.10.09	42
43.10.09	43	43.10.09	43
44.10.09	44	44.10.09	44
45.10.09	45	45.10.09	45
46.10.09	46	46.10.09	46
47.10.09	47	47.10.09	47
48.10.09	48	48.10.09	48
49.10.09	49	49.10.09	49
50.10.09	50	50.10.09	50
51.10.09	51	51.10.09	51
52.10.09	52	52.10.09	52
53.10.09	53	53.10.09	53
54.10.09	54	54.10.09	54
55.10.09	55	55.10.09	55
56.10.09	56	56.10.09	56
57.10.09	57	57.10.09	57
58.10.09	58	58.10.09	58
59.10.09	59	59.10.09	59
60.10.09	60	60.10.09	60
61.10.09	61	61.10.09	61
62.10.09	62	62.10.09	62
63.10.09	63	63.10.09	63
64.10.09	64	64.10.09	64
65.10.09	65	65.10.09	65
66.10.09	66	66.10.09	66
67.10.09	67	67.10.09	67
68.10.09	68	68.10.09	68
69.10.09	69	69.10.09	69
70.10.09	70	70.10.09	70
71.10.09	71	71.10.09	71
72.10.09	72	72.10.09	72
73.10.09	73	73.10.09	73
74.10.09	74	74.10.09	74
75.10.09	75	75.10.09	75
76.10.09	76	76.10.09	76
77.10.09	77	77.10.09	77
78.10.09	78	78.10.09	78
79.10.09	79	79.10.09	79
80.10.09	80	80.10.09	80
81.10.09	81	81.10.09	81
82.10.09	82	82.10.09	82
83.10.09	83	83.10.09	83
84.10.09	84	84.10.09	84
85.10.09	85	85.10.09	85
86.10.09	86	86.10.09	86
87.10.09	87	87.10.09	87
88.10.09	88	88.10.09	88
89.10.09	89	89.10.09	89
90.10.09	90	90.10.09	90
91.10.09	91	91.10.09	91
92.10.09	92	92.10.09	92
93.10.09	93	93.10.09	93
94.10.09	94	94.10.09	94
95.10.09	95	95.10.09	95
96.10.09	96	96.10.09	96
97.10.09	97	97.10.09	97
98.10.09	98	98.10.09	98
99.10.09	99	99.10.09	99
100.10.09	100	100.10.09	100

NOT SHOWN TO DIMENSIONS
 ALLIGY FOR PACKAGING
 BY THE CUSTOMER OPERATING THE PRESSURE

REVISONS		DATE	BY	APPV
01	REV			
SEE SHEET 002				

KEYS
 K A B C D
 E F G H



		AMP KOREA Kyungsan, Korea	
AIR BAG 75P HEADER ASSEMBLY(A-II)			
PART NO. 00779		REFERENCE TO 1742336	
CUSTOMER DRAWING		SHEET 2/11	

