

NOT BEARING TO OPERATOR RELEASED FOR REUSE
 IF THIS ELECTRONIC COMPONENT IS NOT REUSED

REV	DATE	REVISIONS	BY	CHK	APP
S	REVISED	(FC00-0039-02)	SH/AN	YH	CS
T	REVISED	(FC00-0002-03)	SH/AN	YH	CS
U	REVISED	(FC00-0072-03)	SH/AN	YH	CS
V	REVISED	(FC00-0008-04)	SH/AN	YH	CS
W	REVISED	(FC00-0048-04)	SH/AN	YH	CS
Y	REVISED	(EGR-06-028031)	HA/PM/SH	BH	JK

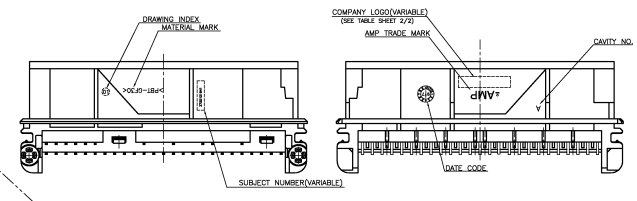

- NOTES
- PIN CONTACT : ± 0.03
 - MATERIAL : Cu96
 - FINISH : SEE TABLE SHEET 2/2
 - SLECTING FORCE IN DIRECTION OF CONNECTION (DETECTION AS SEPARATE OPERATION)
 - >20N but $\leq 250\text{mm/min}$ AFTER SOLDERING STRESS
 - >40N but $\leq 100\text{mm/min}$
 - ENVIRONMENTAL REQUIREMENTS ACCORDING TO AMP SPEC 108-61031
 - NO MOSHIR-EFFECT BY ASSEMBLY FORCE $\leq 50\text{N}$
 - DRAWING KEY B (D-H)
 - FREE OF LOOSE METAL PARTS
 - PIN CONNECTOR : FREE OF CADMIUM ($\leq 50\text{ppm}$)
 - INSULATING BODY
 - MATERIAL : PBT + GF30K
 - COLOR : CONSULT THE DRAWING
 - ALLOWED RECYCLED MATERIAL MAX 25%
 - IN THE AREA OF MOSHIR FREE SPACE THERE IS UP TO ± 0.2 PERMISSIBLE
 - SOLDERING AREA
 - MEASURED TO THE CENTER LINE OF THE INSULATING BODY
 - CONNECTIONS SUITABLE FOR HOLE DIAMETER 1.3, SEE PC-BOARD LAYOUT
 - MEASURED AT PIN TOP(7MM ABOVE BOTTOM)
 - MEASURED AT THE BOTTOM
 - MEASUREMENT POINTS FOR REFERENCE \square AND \square
 - MEASUREMENT POINTS FOR REFERENCE \square AND \square

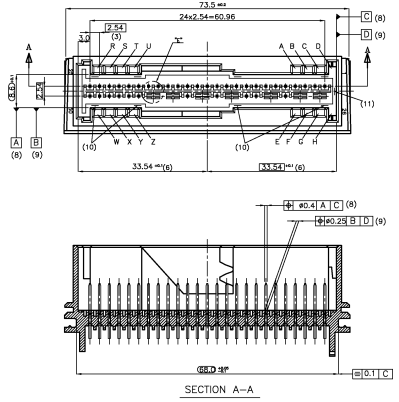
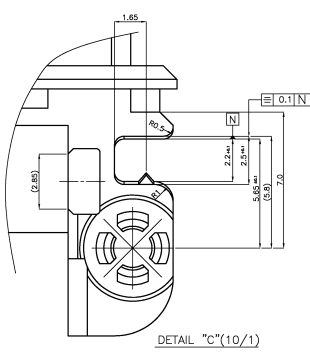
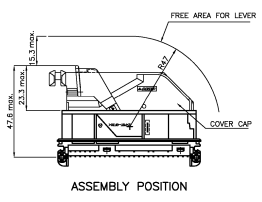
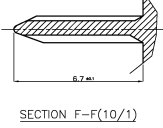
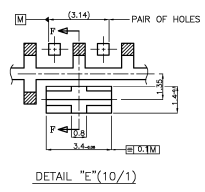
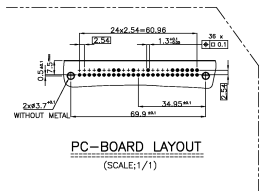
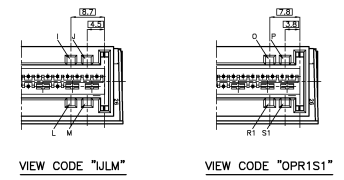
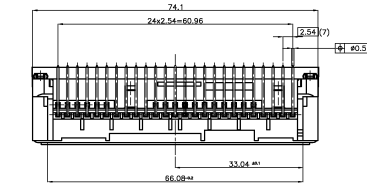
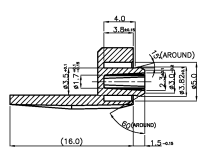
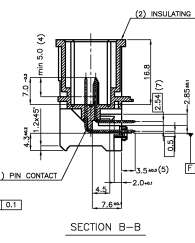
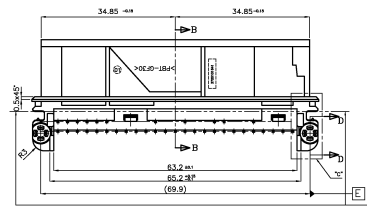
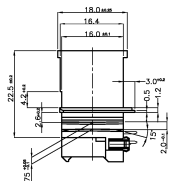

PARTS LIST QTY PART NO DESCRIPTION UNIT SEE NOTE	DRAWING INDEX DRAWING NO PROJECT SPEC APPLICATION SPEC SEE NOTE & TABLE	DATE 00779 CUSTOMER DRAWING	AMP KOREA Kyungson, Korea AIR BAG 50P HEADER ASSY 368213 SCALE: 2/1 SHEET 1 OF 2 REV. Y
---	---	-----------------------------------	--

KEY-CODE LAYOUT

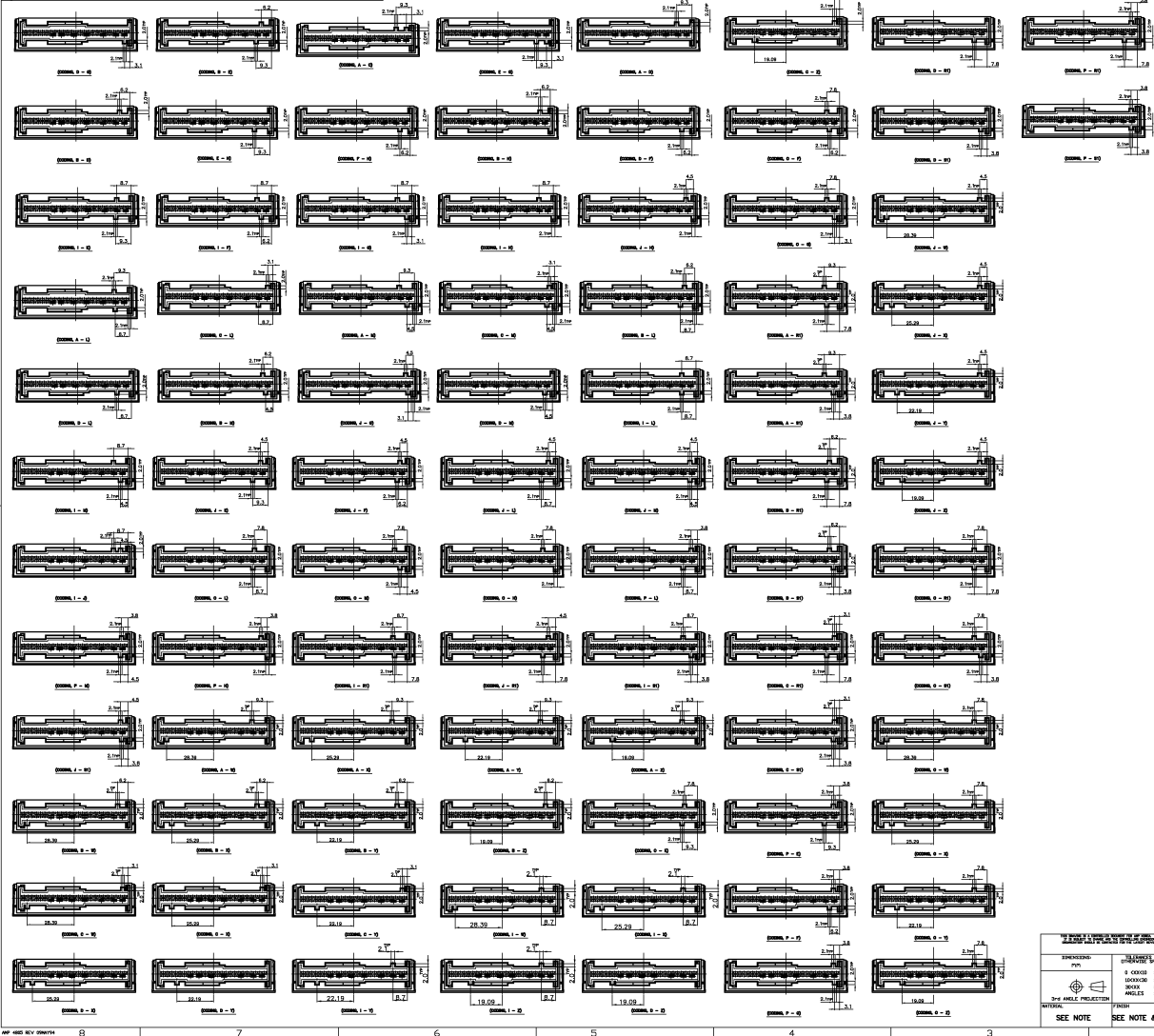

REVISED		DATE		BY		CHK	
NO.	DESCRIPTION	DATE	BY	CHK	DATE	BY	CHK
1	INITIAL						

SEE 1 OF 2 SHEET

NO.	DESCRIPTION	DATE	BY	CHK	DATE	BY	CHK
1.1	INITIAL						
1.2	INITIAL						
1.3	INITIAL						
1.4	INITIAL						
1.5	INITIAL						
1.6	INITIAL						
1.7	INITIAL						
1.8	INITIAL						
1.9	INITIAL						
1.10	INITIAL						
1.11	INITIAL						
1.12	INITIAL						
1.13	INITIAL						
1.14	INITIAL						
1.15	INITIAL						
1.16	INITIAL						
1.17	INITIAL						
1.18	INITIAL						
1.19	INITIAL						
1.20	INITIAL						
1.21	INITIAL						
1.22	INITIAL						
1.23	INITIAL						
1.24	INITIAL						
1.25	INITIAL						
1.26	INITIAL						
1.27	INITIAL						
1.28	INITIAL						
1.29	INITIAL						
1.30	INITIAL						
1.31	INITIAL						
1.32	INITIAL						
1.33	INITIAL						
1.34	INITIAL						
1.35	INITIAL						
1.36	INITIAL						
1.37	INITIAL						
1.38	INITIAL						
1.39	INITIAL						
1.40	INITIAL						
1.41	INITIAL						
1.42	INITIAL						
1.43	INITIAL						
1.44	INITIAL						
1.45	INITIAL						
1.46	INITIAL						
1.47	INITIAL						
1.48	INITIAL						
1.49	INITIAL						
1.50	INITIAL						
1.51	INITIAL						
1.52	INITIAL						
1.53	INITIAL						
1.54	INITIAL						
1.55	INITIAL						
1.56	INITIAL						
1.57	INITIAL						
1.58	INITIAL						
1.59	INITIAL						
1.60	INITIAL						
1.61	INITIAL						
1.62	INITIAL						
1.63	INITIAL						
1.64	INITIAL						
1.65	INITIAL						
1.66	INITIAL						
1.67	INITIAL						
1.68	INITIAL						
1.69	INITIAL						
1.70	INITIAL						
1.71	INITIAL						
1.72	INITIAL						
1.73	INITIAL						
1.74	INITIAL						
1.75	INITIAL						
1.76	INITIAL						
1.77	INITIAL						
1.78	INITIAL						
1.79	INITIAL						
1.80	INITIAL						
1.81	INITIAL						
1.82	INITIAL						
1.83	INITIAL						
1.84	INITIAL						
1.85	INITIAL						
1.86	INITIAL						
1.87	INITIAL						
1.88	INITIAL						
1.89	INITIAL						
1.90	INITIAL						
1.91	INITIAL						
1.92	INITIAL						
1.93	INITIAL						
1.94	INITIAL						
1.95	INITIAL						
1.96	INITIAL						
1.97	INITIAL						
1.98	INITIAL						
1.99	INITIAL						
1.100	INITIAL						

AMP KOREA
 Kyungson, Korea
AIR BAG 50P HEADER ASS'Y
 DRAWING NO. 100779
 DATE 2/1/07
 REV. 2