

NOT DRAWING TO DIMENSIONS
 ALL DIMENSIONS IN MILLIMETERS
 UNLESS OTHERWISE SPECIFIED

| REV | DATE | DESCRIPTION | BY | CHK | APP |
|-----|---------|-----------------|-------|-----|-----|
| S | REVISED | (F000-0039-02) | SS/AN | NS | CS |
| T | REVISED | (F000-0002-03) | NS/AN | NS | CS |
| U | REVISED | (F000-0072-03) | NS/AN | NS | CS |
| V | REVISED | (F000-0008-04) | NS/AN | NS | CS |
| W | REVISED | (F000-0048-04) | NS/AN | NS | CS |
| Y | REVISED | (ECR-06-028031) | NS/AN | NS | CS |

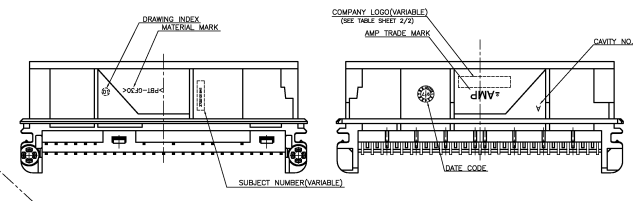

- NOTES**
- PIN CONTACT : ±0.03
 1) MATERIAL : Cu96
 2) FINISH : SEE TABLE SHEET 2/2
 3) EXERCISE FORCE IN DIRECTION OF CONNECTION (DETECTION AS SEPARATE OPERATION)
 * >20N but <=20mm/min, AFTER SOLDERING STRESS
 * >40N but <=100mm/min
 - INSULATING BODY
 1) MATERIAL : PBT ± GF30K
 2) COLOR : CONSULT THE DRAWING
 3) ALLOWED RECYCLED MATERIAL MAX 25%
 4) ENVIRONMENTAL REQUIREMENTS ACCORDING TO AMP SPEC 108-61031
 * NO MOSHIR-EFFECT BY ASSEMBLY FORCE <= 50N
 * DRAWING KEY B (D-H)
 * FREE OF LOOSE METAL PARTS
 * PIN CONNECTOR : FREE OF CADMIUM (<= 50ppm)
 - NO MOSHIR-EFFECT BY ASSEMBLY FORCE <= 50N
 - IN THE AREA OF MOSHIR FREE SPACE THERE IS UP TO ±0.2 PERMISSIBLE
 - MATING AREA
 - SOLDERING AREA
 - MEASURED TO THE CENTER LINE OF THE INSULATING BODY
 - CONNECTIONS SUITABLE FOR HOLE DIAMETER 1.3, SEE PC-BOARD LAYOUT
 - MEASURED AT PIN TOP(7MM ABOVE BOTTOM)
 - MEASURED AT THE BOTTOM
 - MEASUREMENT POINTS FOR REFERENCE (A) AND (B)
 (1) MEASUREMENT POINTS FOR REFERENCE (C) AND (D)

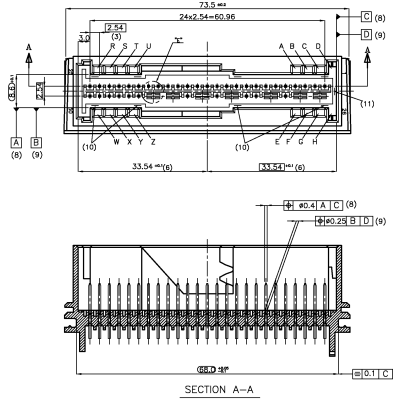
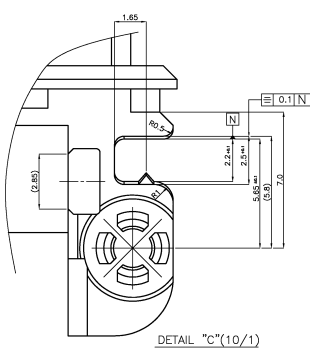
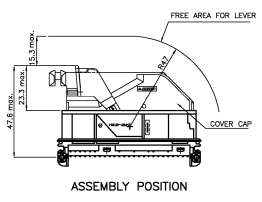
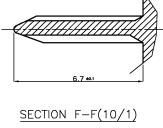
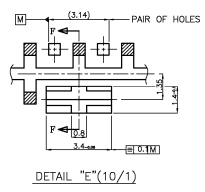
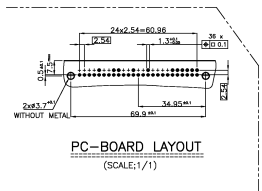
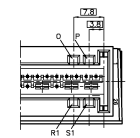
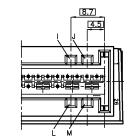
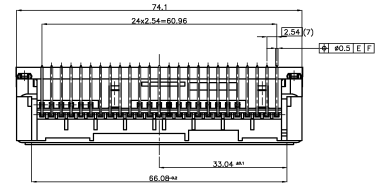
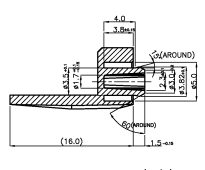
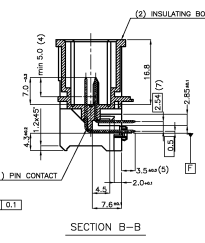
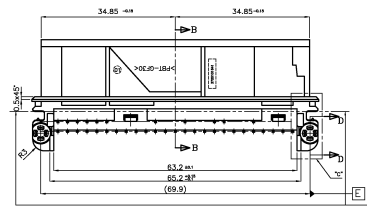
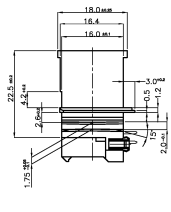

| | | | | | |
|---|-------------------|------------------|------------|------------|--------|
| WORLDWIDE ELECTRONIC COMPONENTS DISTRIBUTOR | DATE THIS DRAWING | REVISED BY | DATE | REVISED BY | DATE |
| SEE NOTE | SEE NOTE & TABLE | CUSTOMER DRAWING | SCALE: 2/1 | SHEET 1 | REV. Y |

KEY-CODE LAYOUT

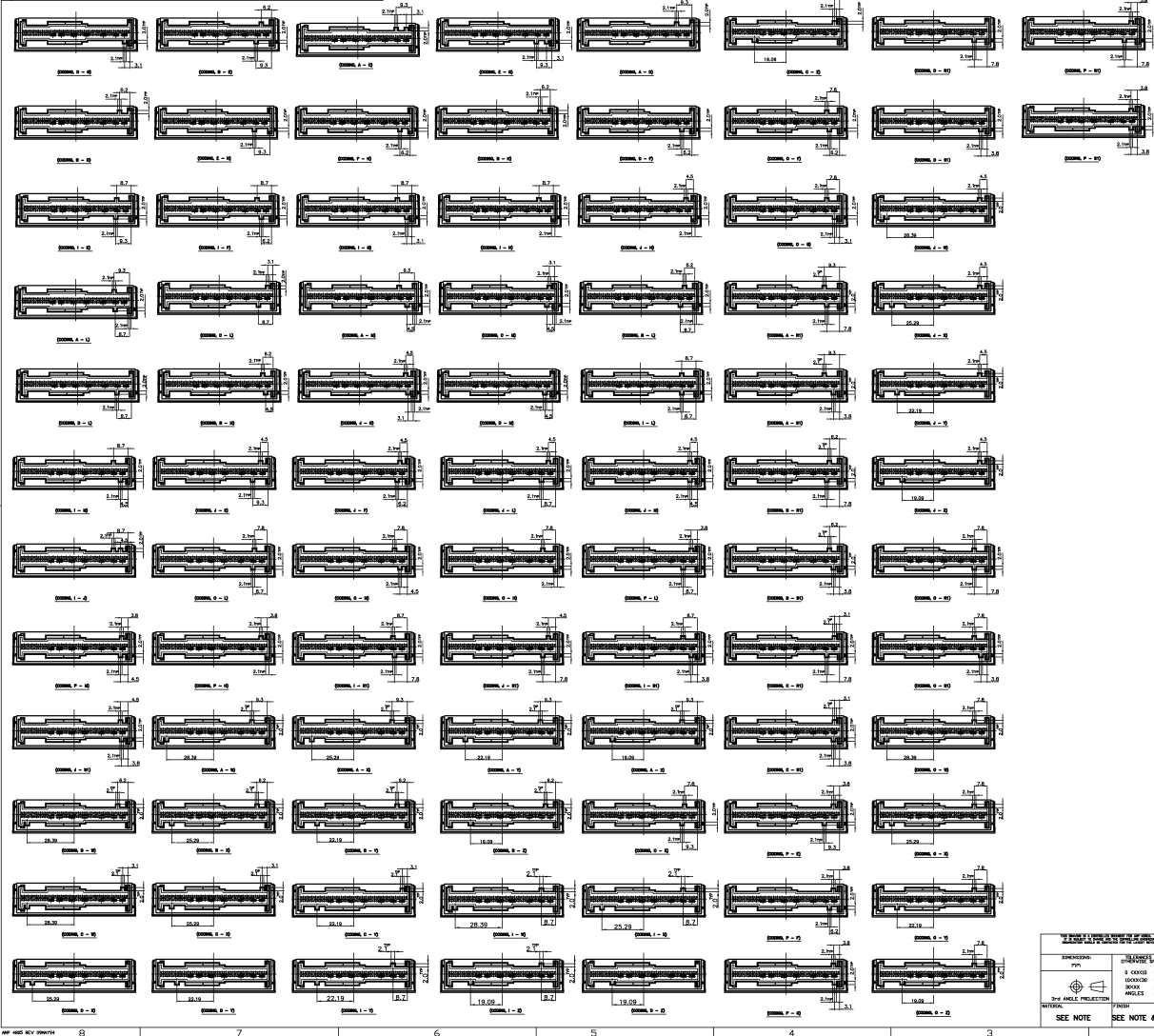

| REVISONS | | DATE | BY | CHK | APPV |
|----------|---------|------|----|-----|------|
| 1 | INITIAL | | | | |

| NO. | DATE | DESCRIPTION | BY | CHK | APPV |
|-----|------|-------------|----|-----|------|
| 1 | | | | | |
| 2 | | | | | |
| 3 | | | | | |
| 4 | | | | | |
| 5 | | | | | |
| 6 | | | | | |
| 7 | | | | | |
| 8 | | | | | |
| 9 | | | | | |
| 10 | | | | | |
| 11 | | | | | |
| 12 | | | | | |
| 13 | | | | | |
| 14 | | | | | |
| 15 | | | | | |
| 16 | | | | | |
| 17 | | | | | |
| 18 | | | | | |
| 19 | | | | | |
| 20 | | | | | |
| 21 | | | | | |
| 22 | | | | | |
| 23 | | | | | |
| 24 | | | | | |
| 25 | | | | | |
| 26 | | | | | |
| 27 | | | | | |
| 28 | | | | | |
| 29 | | | | | |
| 30 | | | | | |
| 31 | | | | | |
| 32 | | | | | |
| 33 | | | | | |
| 34 | | | | | |
| 35 | | | | | |
| 36 | | | | | |
| 37 | | | | | |
| 38 | | | | | |
| 39 | | | | | |
| 40 | | | | | |
| 41 | | | | | |
| 42 | | | | | |
| 43 | | | | | |
| 44 | | | | | |
| 45 | | | | | |
| 46 | | | | | |
| 47 | | | | | |
| 48 | | | | | |
| 49 | | | | | |
| 50 | | | | | |
| 51 | | | | | |
| 52 | | | | | |
| 53 | | | | | |
| 54 | | | | | |
| 55 | | | | | |
| 56 | | | | | |
| 57 | | | | | |
| 58 | | | | | |
| 59 | | | | | |
| 60 | | | | | |
| 61 | | | | | |
| 62 | | | | | |
| 63 | | | | | |
| 64 | | | | | |
| 65 | | | | | |
| 66 | | | | | |
| 67 | | | | | |
| 68 | | | | | |
| 69 | | | | | |
| 70 | | | | | |
| 71 | | | | | |
| 72 | | | | | |
| 73 | | | | | |
| 74 | | | | | |
| 75 | | | | | |
| 76 | | | | | |
| 77 | | | | | |
| 78 | | | | | |
| 79 | | | | | |
| 80 | | | | | |
| 81 | | | | | |
| 82 | | | | | |
| 83 | | | | | |
| 84 | | | | | |
| 85 | | | | | |
| 86 | | | | | |
| 87 | | | | | |
| 88 | | | | | |
| 89 | | | | | |
| 90 | | | | | |
| 91 | | | | | |
| 92 | | | | | |
| 93 | | | | | |
| 94 | | | | | |
| 95 | | | | | |
| 96 | | | | | |
| 97 | | | | | |
| 98 | | | | | |
| 99 | | | | | |
| 100 | | | | | |

AMP KOREA
 Kyungson, Korea
AIR BAG 50P HEADER ASS'Y
 DRAWING NO: 100779
 DATE: 2/1/07
 REV: 2

PREPARED BY: P.M.
 CHECKED BY: S.B.
 DRAWN BY: S.B.
 INKED BY: S.B.
 APPROVED BY: S.B.

SEE NOTE
 SEE NOTE & TABLE
 CUSTOMER DRAWING