

THIS DRAWING IS UNPUBLISHED. RELEASED FOR PUBLICATION
 © COPYRIGHT BY TYCO ELECTRONICS CORPORATION ALL RIGHTS RESERVED.

LOC	DIST	REVISIONS			
P	LTR	DESCRIPTION	DATE	DWN	APVD
B		REVISED ECN (FC00-0129-01)	22.NOV.'01	JW	CS
B1		REVISED (ECR-08-030171)	05.DEC.'08	KT	HG

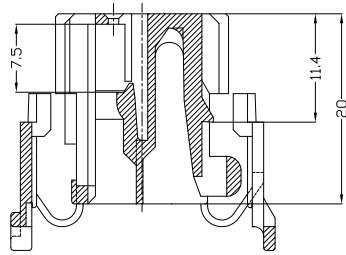
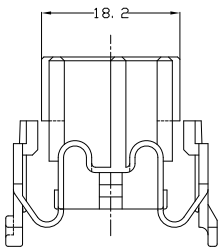
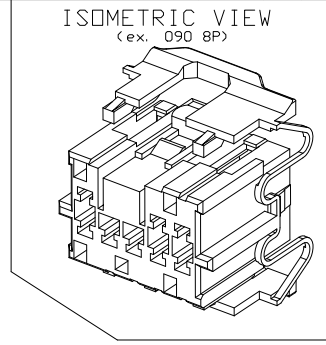
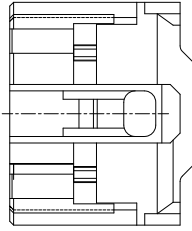
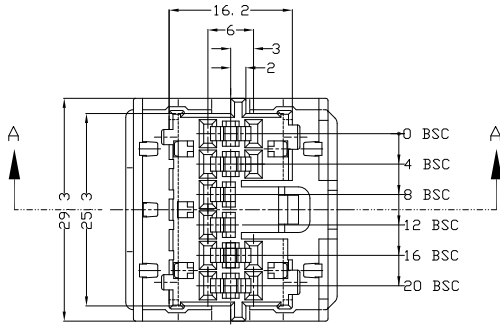

- NOTES.
1. TO BE MATED WITH CAP HSG SMOOTHLY.
 2. APPLIED CONTACT P/N ; 368083/368084/368085
 3. APPLIED CAP HSG P/N ; 1-368177-1

GRAY	PBT	1-368178-3
NATURAL	PBT	1-368178-1
COLOR	MATERIAL	P/N

<small>THIS DRAWING IS A CONTROLLED DOCUMENT FOR TYCO ELECTRONICS CORPORATION IT IS SUBJECT TO CHANGE AND THE CONTROLLING ENGINEERING ORGANIZATION SHOULD BE CONTACTED FOR THE LATEST REVISIONS.</small>		DWN KT_JUNG CHK JW_JUNG APVD HS_OHD PRODUCT SPEC - APPLICATION SPEC - WEIGHT -	AMP KOREA, Kyungsan, Korea
DIMENSIONS: MM 	TOLERANCES UNLESS OTHERWISE SPECIFIED: 0 <XXX<10 ± 0.2 10<XXX<30 ± 0.25 30<XXX ± 0.3 ANGLES ± 3°	NAME .090 MLC 10P PLUG HSG SIZE CAGE CODE DRAWING NO A3 00779 C=368178	RESTRICTED TO -
MATERIAL SEE TABLE	FINISH	CUSTOMER DRAWING SCALE 2/1 SHEET 1 OF 1 REV B1	