

IN555

Timing Circuit

The IN555 monolithic timing circuit is a highly stable controller capable of producing accurate time delays, or oscillation.

- Direct Replacement for NE555 Timers
- Timing From Microseconds Through Hours
- Operates in Both Astable and Monostable Modes
- High Current Output Can Source or Sink 200 mA

PIN ASSIGNMENT

GND	1 ●	8	V_{CC}
Trigger	2	7	Discharge
Output	3	6	Threshold
Reset	4	5	Control Voltage

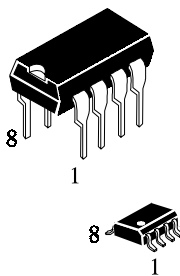

N SUFFIX PLASTIC

D SUFFIX SOIC

ORDERING INFORMATION
 IN555N Plastic
 IN555D SOIC
 $T_A = -10^\circ$ to 70° C for all packages

LOGIC DIAGRAM

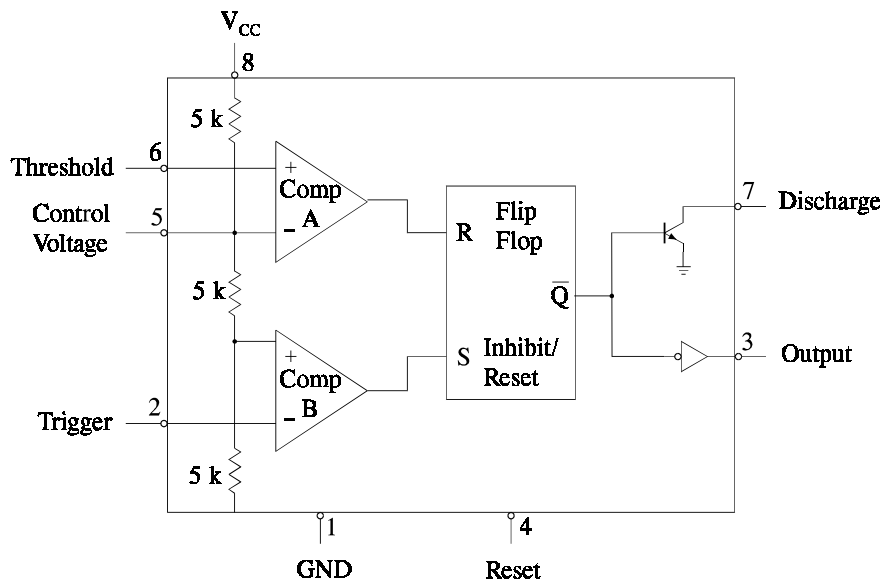

MAXIMUM RATINGS*

Symbol	Parameter	Value	Unit
V _{CC}	Supply Voltage	18	V
T _{stg}	Storage Temperature	-60 to +85	°C

RECOMMENDED OPERATING CONDITIONS

Symbol	Parameter	Min	Max	Unit
V _{CC}	Supply Voltage	4.5	16	V
T _A	Operating Temperature, All Package Types	-10	+70	°C

ELECTRICAL CHARACTERISTICS(T_A =+25°C)

Symbol	Parameter	Test Conditions	Guaranteed Limits		Unit
			Min	Max	
I _{CC}	Supply Current	V _{CC} =5.0 V, R _L =∞ V _{CC} =15 V, R _L =∞		6.0 15	mA
	Timing Error	R=1.0 kΩ to 100 kΩ Initial Accuracy C = 0.1 μF V _{CC} =5.0 V and V _{CC} =15 V		4	%
V _{th}	Threshold Voltage	V _{CC} =5.0 V V _{CC} =15 V	2.6 9	4.0 11	V
V _T	Trigger Voltage	V _{CC} =5.0 V V _{CC} =15 V	1.1 4.5	2.2 5.6	V
I _T	Trigger Current	V ₀₂ =0 V, V _{CC} =15 V V ₀₂ =15 V, V _{CC} =15 V		-2 0.5	μA
V _R	Reset Voltage	V _{CC} =15 V	0.4	1.0	V
I _R	Reset Current	V ₀₄ =0 V, V _{CC} =15 V V ₀₄ =15 V, V _{CC} =15 V		-0.4 0.5	mA μA
I _{th}	Threshold Current (Note 1)	V ₀₆ =0 V, V _{CC} =15 V V ₀₆ =10 V, V _{CC} =15 V		-0.5 0.25	μA
I _{dis}	Discharge Leakage Current (Pin 7)	V _{CC} =15 V, V ₀₇ =15 V		100	nA
V _{REF}	Control Voltage Level	V _{CC} =15 V V _{CC} =5.0 V	9.0 2.6	11 4.0	V
V _{OL}	Output Voltage Low	(V _{CC} =15 V) I _{sink} =10 mA, I _{sink} =50 mA, I _{sink} =100 mA, V _{CC} =5.0 V, I _{sink} =5.0 mA		0.25 0.75 2.3 0.35	V
V _{OH}	Output Voltage High	I _{source} =200 mA, V _{CC} =15 V I _{source} =100 mA, V _{CC} =15 V I _{source} =100 mA, V _{CC} =5.0 V	12 12.75 2.75		V
t _{OLH}	Rise Time of Output	V _{CC} =15 V		150	ns
t _{OHL}	Fall Time of Output	V _{CC} =15 V		150	ns

Note 1. This will determine the maximum value of R_A + R_B for 15 V operation.
The maximum total R=20 MΩ.