

## 4M x 16bit CMOS Dynamic RAM with Extended Data Out

### DESCRIPTION

This is a family of 4,194,304 x 16 bit Extended Data Out Mode CMOS DRAMs. Extended Data Out Mode offers high speed random access of memory cells within the same row. Refresh cycle(4K Ref. or 8K Ref.), access time (-45, -5 or -6) are optional features of this family. All of this family have  $\overline{\text{CAS}}$ -before- $\overline{\text{RAS}}$  refresh,  $\overline{\text{RAS}}$ -only refresh and Hidden refresh capabilities. This 4Mx16 EDO Mode DRAM family is fabricated using Samsung's advanced CMOS process to realize high band-width, low power consumption and high reliability.

### FEATURES

#### Part Identification

- KM416C4004B(5.0V, 8K Ref.)
- KM416C4104B(5.0V, 4K Ref.)

#### Active Power Dissipation

Unit : mW

Speed	8K	4K
-45	550	715
-5	495	660
-6	440	605

#### Refresh Cycles

Part NO.	Refresh cycle	Refresh time
		Normal
KM416C4004B*	8K	64ms
KM416C4104B	4K	

- \* Access mode &  $\overline{\text{RAS}}$  only refresh mode : 8K cycle/64ms  
 $\overline{\text{CAS}}$ -before- $\overline{\text{RAS}}$  & Hidden refresh mode : 4K cycle/64ms

#### Performance Range

Speed	t <sub>RAC</sub>	t <sub>CAC</sub>	t <sub>RC</sub>	t <sub>HPC</sub>
-45	45ns	12ns	74ns	17ns
-5	50ns	13ns	84ns	20ns
-6	60ns	15ns	104ns	25ns

- Extended Data Out Mode operation
- 2  $\overline{\text{CAS}}$  Byte/Word Read/Write operation
- $\overline{\text{CAS}}$ -before- $\overline{\text{RAS}}$  refresh capability
- $\overline{\text{RAS}}$ -only and Hidden refresh capability
- Fast parallel test mode capability
- TTL(5.0V) compatible inputs and outputs
- Early Write or output enable controlled write
- JEDEC Standard pinout
- Available in Plastic TSOP(II) package
- +5.0V±10% power supply

### FUNCTIONAL BLOCK DIAGRAM

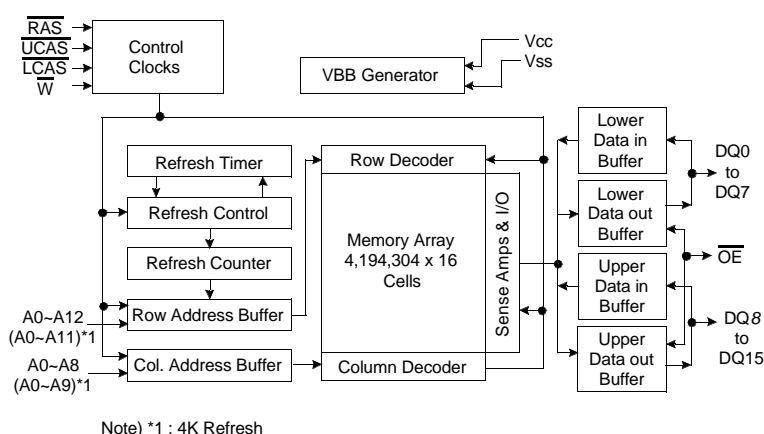

**SAMSUNG ELECTRONICS CO., LTD.** reserves the right to change products and specifications without notice.

PIN CONFIGURATION (Top Views)

• KM416C40(1)04BS

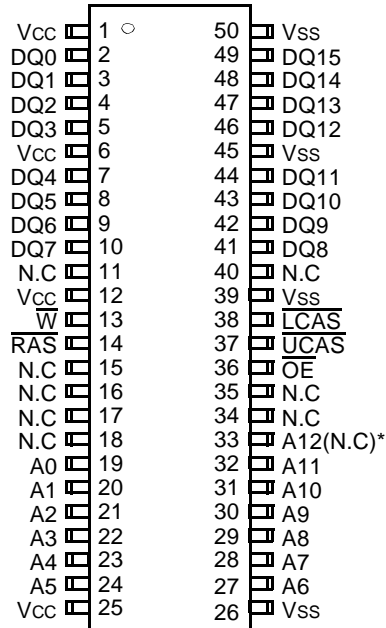

(400mil TSOP(II))

\*(N.C) : N.C for 4K Refresh Product

Pin Name	Pin function
A0 - A12	Address Inputs(8K Product)
A0 - A11	Address Inputs(4K Product)
DQ0 - 15	Data In/Out
Vss	Ground
$\overline{RAS}$	Row Address Strobe
$\overline{UCAS}$	Upper Column Address Strobe
$\overline{LCAS}$	Lower Column Address Strobe
$\overline{W}$	Read/Write Input
$\overline{OE}$	Data Output Enable
Vcc	Power(+5.0V)
N.C	No Connection

**ABSOLUTE MAXIMUM RATINGS**

Parameter	Symbol	Rating	Units
Voltage on any pin relative to Vss	V <sub>IN</sub> , V <sub>OUT</sub>	-1.0 to +7.0	V
Voltage on Vcc supply relative to Vss	V <sub>CC</sub>	-1.0 to +7.0	V
Storage Temperature	T <sub>stg</sub>	-55 to +150	°C
Power Dissipation	P <sub>D</sub>	1	W
Short Circuit Output Current	I <sub>OS</sub>	50	mA

\* Permanent device damage may occur if "ABSOLUTE MAXIMUM RATINGS" are exceeded. Functional operation should be restricted to the conditions as detailed in the operational sections of this data sheet. Exposure to absolute maximum rating conditions for extended periods may affect device reliability.

**RECOMMENDED OPERATING CONDITIONS** (Voltage referenced to Vss, T<sub>A</sub>= 0 to 70°C)

Parameter	Symbol	Min	Typ	Max	Units
Supply Voltage	V <sub>CC</sub>	4.5	5.0	5.5	V
Ground	V <sub>SS</sub>	0	0	0	V
Input High Voltage	V <sub>IH</sub>	2.4	-	V <sub>CC</sub> +1.0* <sup>1</sup>	V
Input Low Voltage	V <sub>IL</sub>	-1.0* <sup>2</sup>	-	0.8	V

\*1 : V<sub>CC</sub>+2.0V at pulse width ≤ 20ns which is measured at V<sub>CC</sub>

\*2 : -2.0 at pulse width ≤ 20ns which is measured at V<sub>SS</sub>

**DC AND OPERATING CHARACTERISTICS** (Recommended operating conditions unless otherwise noted.)

Parameter	Symbol	Min	Max	Units
Input Leakage Current (Any input 0 ≤ V <sub>IN</sub> ≤ V <sub>CC</sub> +0.5V, all other pins not under test=0 Volt)	I <sub>I(L)</sub>	-5	5	uA
Output Leakage Current (Data out is disabled, 0V ≤ V <sub>OUT</sub> ≤ V <sub>CC</sub> )	I <sub>O(L)</sub>	-5	5	uA
Output High Voltage Level(I <sub>OH</sub> =-5mA)	V <sub>OH</sub>	2.4	-	V
Output Low Voltage Level(I <sub>OL</sub> =4.2mA)	V <sub>OL</sub>	-	0.4	V

**DC AND OPERATING CHARACTERISTICS** (Continued)

Symbol	Power	Speed	Max		Units
			KM416C4004B	KM416C4104B	
I <sub>CC1</sub>	Don't care	-45	100	130	mA
		-5	90	120	mA
		-6	80	110	mA
I <sub>CC2</sub>	Normal	Don't care	2	2	mA
I <sub>CC3</sub>	Don't care	-45	100	130	mA
		-5	90	120	mA
		-6	80	110	mA
I <sub>CC4</sub>	Don't care	-45	110	120	mA
		-5	100	110	mA
		-6	90	100	mA
I <sub>CC5</sub>	Normal	Don't care	1	1	mA
I <sub>CC6</sub>	Don't care	-45	100	130	mA
		-5	90	120	mA
		-6	80	110	mA

I<sub>CC1</sub>\* : Operating Current ( $\overline{RAS}$  and  $\overline{UCAS}$ ,  $\overline{LCAS}$ , Address cycling @t<sub>RC</sub>=min.)

I<sub>CC2</sub> : Standby Current ( $\overline{RAS}=\overline{UCAS}=\overline{LCAS}=\overline{W}=V_{IH}$ )

I<sub>CC3</sub>\* :  $\overline{RAS}$ -only Refresh Current ( $\overline{UCAS}=\overline{LCAS}=V_{IH}$ ,  $\overline{RAS}$ , Address cycling @t<sub>RC</sub>=min.)

I<sub>CC4</sub>\* : Extended Data Out Mode Current ( $\overline{RAS}=V_{IL}$ ,  $\overline{UCAS}$  or  $\overline{LCAS}$ , Address cycling @t<sub>HPC</sub>=min.)

I<sub>CC5</sub> : Standby Current ( $\overline{RAS}=\overline{UCAS}=\overline{LCAS}=\overline{W}=V_{CC}-0.2V$ )

I<sub>CC6</sub>\* :  $\overline{CAS}$ -Before- $\overline{RAS}$  Refresh Current ( $\overline{RAS}$  and  $\overline{UCAS}$  or  $\overline{LCAS}$  cycling @t<sub>RC</sub>=min)

**\*Note :** I<sub>CC1</sub>, I<sub>CC3</sub>, I<sub>CC4</sub> and I<sub>CC6</sub> are dependent on output loading and cycle rates. Specified values are obtained with the output open. I<sub>CC</sub> is specified as an average current. In I<sub>CC1</sub>, I<sub>CC3</sub> and I<sub>CC6</sub>, address can be changed maximum once while  $\overline{RAS}=V_{IL}$ . In I<sub>CC4</sub>, address can be changed maximum once within one EDO mode cycle time t<sub>HPC</sub>.

# KM416C4004B, KM416C4104B

# CMOS DRAM

## CAPACITANCE (TA=25°C, VCC=5.0V, f=1MHz)

Parameter	Symbol	Min	Max	Units
Input capacitance [A0 ~ A12]	CIN1	-	5	pF
Input capacitance [ $\overline{\text{RAS}}$ , $\overline{\text{UCAS}}$ , $\overline{\text{LCAS}}$ , $\overline{\text{W}}$ , $\overline{\text{OE}}$ ]	CIN2	-	7	pF
Output capacitance [DQ0 - DQ15]	CDQ	-	7	pF

## AC CHARACTERISTICS (0°C ≤ TA ≤ 70°C, See note 1,2)

Test condition : VCC=5.0V±10%, VIH/VIL=2.4/0.8V, VOH/VOL=2.0/0.8V

Parameter	Symbol	-45		-5		-6		Units	Note
		Min	Max	Min	Max	Min	Max		
Random read or write cycle time	tRC	74		84		104		ns	
Read-modify-write cycle time	tRWC	101		116		138		ns	
Access time from $\overline{\text{RAS}}$	tRAC		45		50		60	ns	3,4,10
Access time from $\overline{\text{CAS}}$	tCAC		12		13		15	ns	3,4,5
Access time from column address	tAA		23		25		30	ns	3,10
$\overline{\text{CAS}}$ to output in Low-Z	tCLZ	3		3		3		ns	3
Output buffer turn-off delay from $\overline{\text{CAS}}$	tCEZ	3	13	3	13	3	13	ns	6,21
$\overline{\text{OE}}$ to output in Low-Z	tOLZ	3		3		3		ns	3
Transition time (rise and fall)	tT	1	50	1	50	1	50	ns	2
$\overline{\text{RAS}}$ precharge time	tRP	25		30		40		ns	
$\overline{\text{RAS}}$ pulse width	tRAS	45	10K	50	10K	60	10K	ns	
$\overline{\text{RAS}}$ hold time	tRSH	8		13		15		ns	
$\overline{\text{CAS}}$ hold time	tCSH	35		38		45		ns	
$\overline{\text{CAS}}$ pulse width	tCAS	7	5K	8	10K	10	10K	ns	
$\overline{\text{RAS}}$ to $\overline{\text{CAS}}$ delay time	tRCD	11	33	20	37	20	45	ns	4
$\overline{\text{RAS}}$ to column address delay time	tRAD	9	22	15	25	15	30	ns	10
$\overline{\text{CAS}}$ to $\overline{\text{RAS}}$ precharge time	tCRP	5		5		5		ns	
Row address set-up time	tASR	0		0		0		ns	
Row address hold time	tRAH	7		10		10		ns	
Column address set-up time	tASC	0		0		0		ns	
Column address hold time	tCAH	7		8		10		ns	13
Column address to $\overline{\text{RAS}}$ lead time	tRAL	23		25		30		ns	13
Read command set-up time	tRCS	0		0		0		ns	
Read command hold time referenced to $\overline{\text{CAS}}$	tRCH	0		0		0		ns	8
Read command hold time referenced to $\overline{\text{RAS}}$	tRRH	0		0		0		ns	8
Write command hold time	tWCH	7		10		10		ns	
Write command pulse width	tWP	6		10		10		ns	
Write command to $\overline{\text{RAS}}$ lead time	tRWL	8		13		10		ns	
Write command to $\overline{\text{CAS}}$ lead time	tCWL	7		8		10		ns	16
Data set-up time	tDS	0		0		0		ns	9,19



ELECTRONICS

AC CHARACTERISTICS (Continued)

Parameter	Symbol	-45		-5		-6		Units	Note
		Min	Max	Min	Max	Min	Max		
Data hold time	t <sub>DH</sub>	7		8		10		ns	9,19
Refresh period (4K, Normal)	t <sub>REF</sub>		64		64		64	ms	
Refresh period (8K, Normal)	t <sub>REF</sub>		64		64		64	ms	
Write command set-up time	t <sub>WCS</sub>	0		0		0		ns	7
$\overline{\text{CAS}}$ to $\overline{\text{W}}$ delay time	t <sub>CWD</sub>	24		30		32		ns	7,15
$\overline{\text{RAS}}$ to $\overline{\text{W}}$ delay time	t <sub>RWD</sub>	57		67		77		ns	7
Column address $\overline{\text{W}}$ delay time	t <sub>AWD</sub>	35		42		47		ns	7
$\overline{\text{CAS}}$ set-up time ( $\overline{\text{CAS}}$ -before- $\overline{\text{RAS}}$ refresh)	t <sub>CSR</sub>	5		5		5		ns	17
$\overline{\text{CAS}}$ hold time ( $\overline{\text{CAS}}$ -before- $\overline{\text{RAS}}$ refresh)	t <sub>CHR</sub>	10		10		10		ns	18
$\overline{\text{RAS}}$ to $\overline{\text{CAS}}$ precharge time	t <sub>RPC</sub>	5		5		5		ns	
Access time from $\overline{\text{CAS}}$ precharge	t <sub>CPA</sub>		24		28		35	ns	3
Hyper Page cycle time	t <sub>HPC</sub>	17		20		25		ns	20
Hyper Page read-modify-write cycle time	t <sub>HPRWC</sub>	47		47		56		ns	20
$\overline{\text{CAS}}$ precharge time (Hyper page cycle)	t <sub>CP</sub>	6.5		8		10		ns	14
$\overline{\text{RAS}}$ pulse width (Hyper page cycle)	t <sub>RASP</sub>	45	200K	50	200K	60	200K	ns	
$\overline{\text{RAS}}$ hold time from $\overline{\text{CAS}}$ precharge	t <sub>RHCP</sub>	24		30		35		ns	
$\overline{\text{OE}}$ access time	t <sub>OEA</sub>		12		13		15	ns	
$\overline{\text{OE}}$ to data delay	t <sub>OED</sub>	8		13		13		ns	
$\overline{\text{CAS}}$ precharge to $\overline{\text{W}}$ delay time	t <sub>CPWD</sub>	36		45		54		ns	
Output buffer turn off delay time from $\overline{\text{OE}}$	t <sub>OEZ</sub>	3	11	3	13	3	13	ns	6
$\overline{\text{OE}}$ command hold time	t <sub>OEH</sub>	5		13		15		ns	
Write command set-up time (Test mode in)	t <sub>WTS</sub>	10		10		10		ns	11
Write command hold time (Test mode in)	t <sub>WTH</sub>	10		10		10		ns	11
$\overline{\text{W}}$ to $\overline{\text{RAS}}$ precharge time ( $\overline{\text{C}}$ -B- $\overline{\text{R}}$ refresh)	t <sub>WRP</sub>	10		10		10		ns	
$\overline{\text{W}}$ to $\overline{\text{RAS}}$ hold time ( $\overline{\text{C}}$ -B- $\overline{\text{R}}$ refresh)	t <sub>WRH</sub>	10		10		10		ns	
Output data hold time	t <sub>DOH</sub>	4		5		5		ns	
Output buffer turn off delay from $\overline{\text{RAS}}$	t <sub>REZ</sub>	3	13	3	13	3	13	ns	6,21
Output buffer turn off delay from $\overline{\text{W}}$	t <sub>WEZ</sub>	3	13	3	13	3	13	ns	6
$\overline{\text{W}}$ to data delay	t <sub>WED</sub>	8		15		15		ns	
$\overline{\text{OE}}$ to $\overline{\text{CAS}}$ hold time	t <sub>OCH</sub>	5		5		5		ns	
$\overline{\text{CAS}}$ hold time to $\overline{\text{OE}}$	t <sub>CHO</sub>	5		5		5		ns	
$\overline{\text{OE}}$ precharge time	t <sub>OEP</sub>	5		5		5		ns	
$\overline{\text{W}}$ pulse width (Hyper page cycle)	t <sub>WPE</sub>	5		5		5		ns	
$\overline{\text{RAS}}$ pulse width ( $\overline{\text{C}}$ -B- $\overline{\text{R}}$ self refresh)	t <sub>RASS</sub>	100		100		100		us	22,23,24
$\overline{\text{RAS}}$ precharge time ( $\overline{\text{C}}$ -B- $\overline{\text{R}}$ self refresh)	t <sub>RPS</sub>	74		90		110		ns	22,23,24
$\overline{\text{CAS}}$ hold time ( $\overline{\text{C}}$ -B- $\overline{\text{R}}$ self refresh)	t <sub>CHS</sub>	-50		-50		-50		ns	22,23,24

**TEST MODE CYCLE**
**( Note 11 )**

Parameter	Symbol	-45		-5		-6		Units	Note
		Min	Max	Min	Max	Min	Max		
Random read or write cycle time	t <sub>RC</sub>	79		89		109		ns	
Read-modify-write cycle time	t <sub>RWC</sub>	110		121		145		ns	
Access time from $\overline{\text{RAS}}$	t <sub>RAC</sub>		50		55		65	ns	3,4,10,12
Access time from $\overline{\text{CAS}}$	t <sub>CAC</sub>		17		18		20	ns	3,4,5,12
Access time from column address	t <sub>AA</sub>		28		30		35	ns	3,10,12
$\overline{\text{RAS}}$ pulse width	t <sub>TRAS</sub>	50	10K	55	10K	65	10K	ns	
$\overline{\text{CAS}}$ pulse width	t <sub>CAS</sub>	12	10K	13	10K	15	10K	ns	
$\overline{\text{RAS}}$ hold time	t <sub>RS</sub>	18		18		20		ns	
$\overline{\text{CAS}}$ hold time	t <sub>CS</sub>	39		43		50		ns	
Column Address to $\overline{\text{RAS}}$ lead time	t <sub>RAL</sub>	28		30		35		ns	
$\overline{\text{CAS}}$ to $\overline{\text{W}}$ delay time	t <sub>CWD</sub>	29		35		39		ns	7
$\overline{\text{RAS}}$ to $\overline{\text{W}}$ delay time	t <sub>RWD</sub>	62		72		84		ns	7
Column Address to $\overline{\text{W}}$ delay time	t <sub>AWD</sub>	40		47		54		ns	7
Hyper Page cycle time	t <sub>HPC</sub>	22		25		30		ns	20
Hyper Page read-modify-write cycle time	t <sub>HPRWC</sub>	52		53		61		ns	20
$\overline{\text{RAS}}$ pulse width (Hyper page cycle)	t <sub>RASP</sub>	50	200K	55	200	65	200	ns	
Access time from $\overline{\text{CAS}}$ precharge	t <sub>CPA</sub>		29		33		40	ns	3
$\overline{\text{OE}}$ access time	t <sub>OE</sub>		17		18		20	ns	
$\overline{\text{OE}}$ to data delay	t <sub>OE</sub>	13		18		20		ns	
$\overline{\text{OE}}$ command hold time	t <sub>OE</sub>	13		18		20		ns	

**NOTES**

1. An initial pause of 200us is required after power-up followed by any 8  $\overline{\text{RAS}}$ -only refresh or  $\overline{\text{CAS}}$ -before- $\overline{\text{RAS}}$  refresh cycles before proper device operation is achieved.
2.  $V_{IH}(\text{min})$  and  $V_{IL}(\text{max})$  are reference levels for measuring timing of input signals. Transition times are measured between  $V_{IH}(\text{min})$  and  $V_{IL}(\text{max})$  and are assumed to be 2ns for all inputs.
3. Measured with a load equivalent to 2 TTL load and 100pF.
4. Operation within the  $t_{\text{RCD}}(\text{max})$  limit insures that  $t_{\text{RAC}}(\text{max})$  can be met,  $t_{\text{RCD}}(\text{max})$  is specified as a reference point only. If  $t_{\text{RCD}}$  is greater than the specified  $t_{\text{RCD}}(\text{max})$  limit, then access time is controlled exclusively by  $t_{\text{CAC}}$ .
5. Assumes that  $t_{\text{RCD}} \geq t_{\text{RCD}}(\text{max})$ .
6. These parameter defines the time at which the output achieves the open circuit condition and is not referenced to  $V_{OH}$  or  $V_{OL}$ .
7.  $t_{\text{WCS}}$ ,  $t_{\text{RWD}}$ ,  $t_{\text{CWD}}$  and  $t_{\text{AWD}}$  are non restrictive operating parameters. They are included in the data sheet as electrical characteristics only. If  $t_{\text{WCS}} \geq t_{\text{WCS}}(\text{min})$ , the cycle is an early write cycle and the data output will remain high impedance for the duration of the cycle. If  $t_{\text{CWD}} \geq t_{\text{CWD}}(\text{min})$ ,  $t_{\text{RWD}} \geq t_{\text{RWD}}(\text{min})$  and  $t_{\text{AWD}} \geq t_{\text{AWD}}(\text{min})$ , then the cycle is a read-modify-write cycle and the data output will contain the data read from the selected address. If neither of the above conditions is satisfied, the condition of the data out is indeterminate.
8. Either  $t_{\text{RCH}}$  or  $t_{\text{RRH}}$  must be satisfied for a read cycle.
9. These parameters are referenced to  $\overline{\text{CAS}}$  falling edge in early write cycles and to  $\overline{\text{W}}$  falling edge in  $\overline{\text{OE}}$  controlled write cycle and read-modify-write cycles.
10. Operation within the  $t_{\text{RAD}}(\text{max})$  limit insures that  $t_{\text{RAC}}(\text{max})$  can be met.  $t_{\text{RAD}}(\text{max})$  is specified as a reference point only. If  $t_{\text{RAD}}$  is greater than the specified  $t_{\text{RAD}}(\text{max})$  limit, then access time is controlled by  $t_{\text{AA}}$ .
11. These specifications are applied in the test mode.
12. In test mode read cycle, the value of  $t_{\text{RAC}}$ ,  $t_{\text{AA}}$ ,  $t_{\text{CAC}}$  is delayed by 2ns to 5ns for the specified values. These parameters should be specified in test mode cycles by adding the above value to the specified value in this data sheet.
13.  $t_{\text{ASC}}$ ,  $t_{\text{CAH}}$  are referenced to the earlier  $\overline{\text{CAS}}$  falling edge.
14.  $t_{\text{CP}}$  is specified from the later  $\overline{\text{CAS}}$  rising edge in the previous cycle to the earlier  $\overline{\text{CAS}}$  falling edge in the next cycle.
15.  $t_{\text{CWD}}$  is referenced to the later  $\overline{\text{CAS}}$  falling edge at word read-modify-write cycle.

**KM416C40(1)04B Truth Table**

$\overline{\text{RAS}}$	$\overline{\text{LCAS}}$	$\overline{\text{UCAS}}$	$\overline{\text{W}}$	$\overline{\text{OE}}$	DQ0 - DQ7	DQ8-DQ15	STATE
H	X	X	X	X	Hi-Z	Hi-Z	Standby
L	H	H	X	X	Hi-Z	Hi-Z	Refresh
L	L	H	H	L	DQ-OUT	Hi-Z	Byte Read
L	H	L	H	L	Hi-Z	DQ-OUT	Byte Read
L	L	L	H	L	DQ-OUT	DQ-OUT	Word Read
L	L	H	L	H	DQ-IN	-	Byte Write
L	H	L	L	H	-	DQ-IN	Byte Write
L	L	L	L	H	DQ-IN	DQ-IN	Word Write
L	L	L	H	H	Hi-Z	Hi-Z	-



- 16.  $t_{CWL}$  is specified from  $\overline{W}$  falling edge to the earlier  $\overline{CAS}$  rising edge.
- 17.  $t_{CSR}$  is referenced to the earlier  $\overline{CAS}$  falling edge before  $\overline{RAS}$  transition low.
- 18.  $t_{CHR}$  is referenced to the later  $\overline{CAS}$  rising edge after  $\overline{RAS}$  transition low.

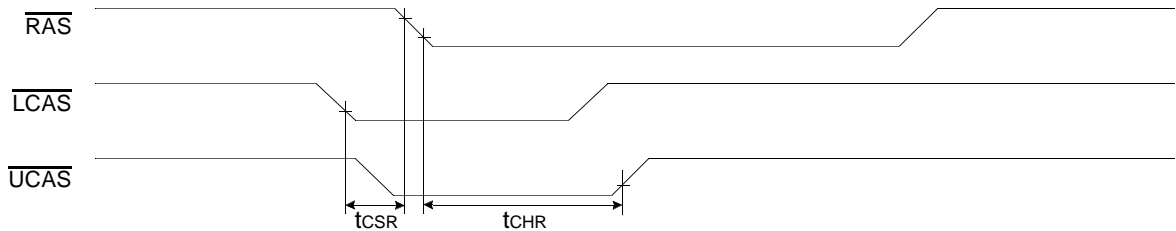

- 19.  $t_{DS}$  is specified for the earlier  $\overline{CAS}$  falling edge and  $t_{DH}$  is specified by the later  $\overline{CAS}$  falling edge in early write cycle.



- 20.  $t_{ASC} \geq 6ns$ , Assume  $t_T = 2.0ns$
- 21. If  $\overline{RAS}$  goes high before  $\overline{CAS}$  high going, the open circuit condition of the output is achieved by  $\overline{CAS}$  high going. If  $\overline{CAS}$  goes high before  $\overline{RAS}$  high going, the open circuit condition of the output is achieved by  $\overline{RAS}$  high going.
- 22. If  $t_{RAS} \geq 100us$ , then  $\overline{RAS}$  precharge time must use  $t_{RPS}$  instead of  $t_{RP}$ .
- 23. For  $\overline{RAS}$ -only refresh and burst  $\overline{CAS}$ -before- $\overline{RAS}$  refresh mode, 4096(4K/8K) cycles of burst refresh must be executed within 64ms before and after self refresh, in order to meet refresh specification.
- 24. For distributed  $\overline{CAS}$ -before- $\overline{RAS}$  with 15.6us interval  $\overline{CAS}$ -before- $\overline{RAS}$  refresh should be executed with in 15.6us immediately before and after self refresh in order to meet refresh specification.

WORD READ CYCLE

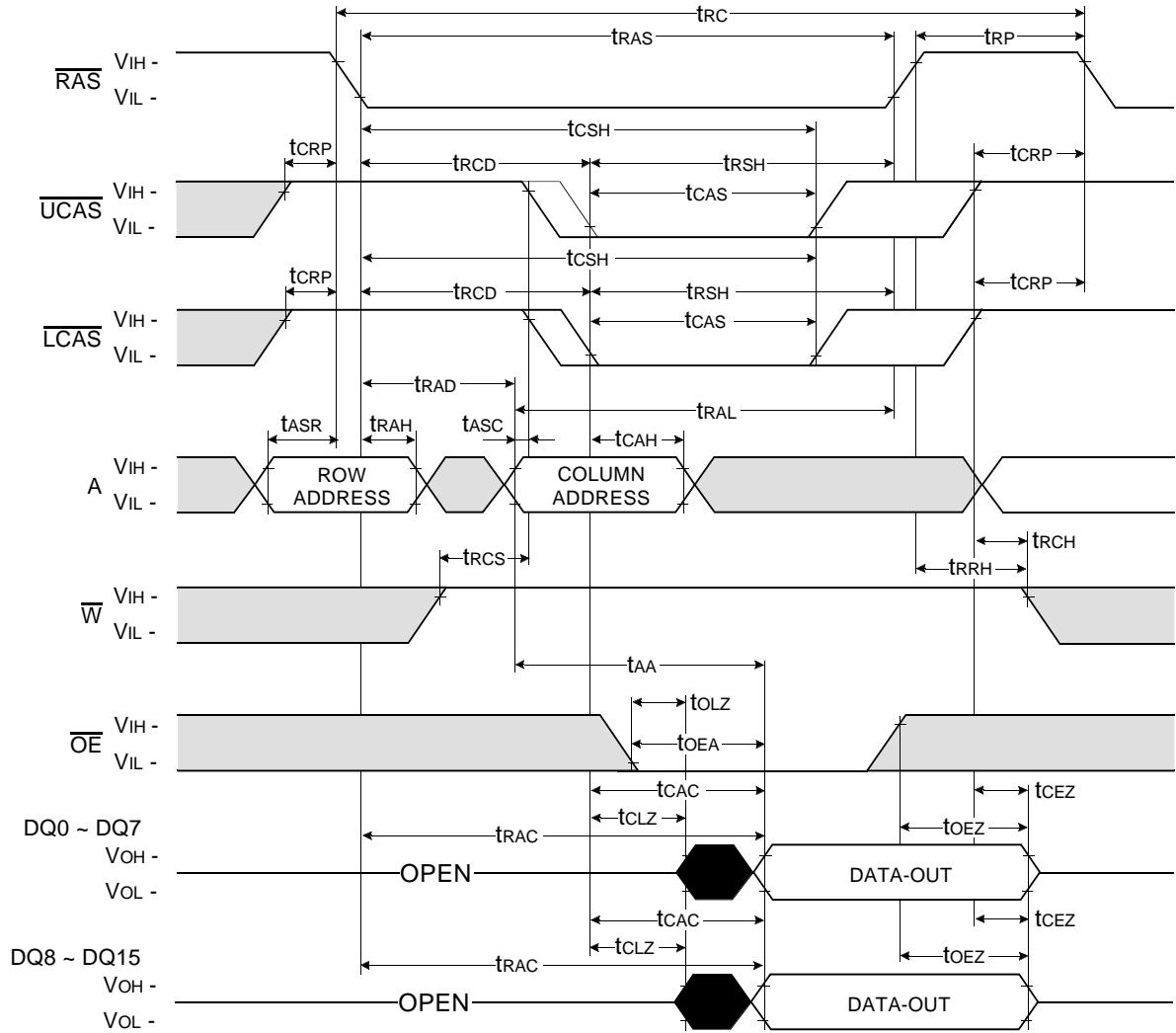

Don't care  
 Undefined

LOWER BYTE READ CYCLE

NOTE : DIN = OPEN

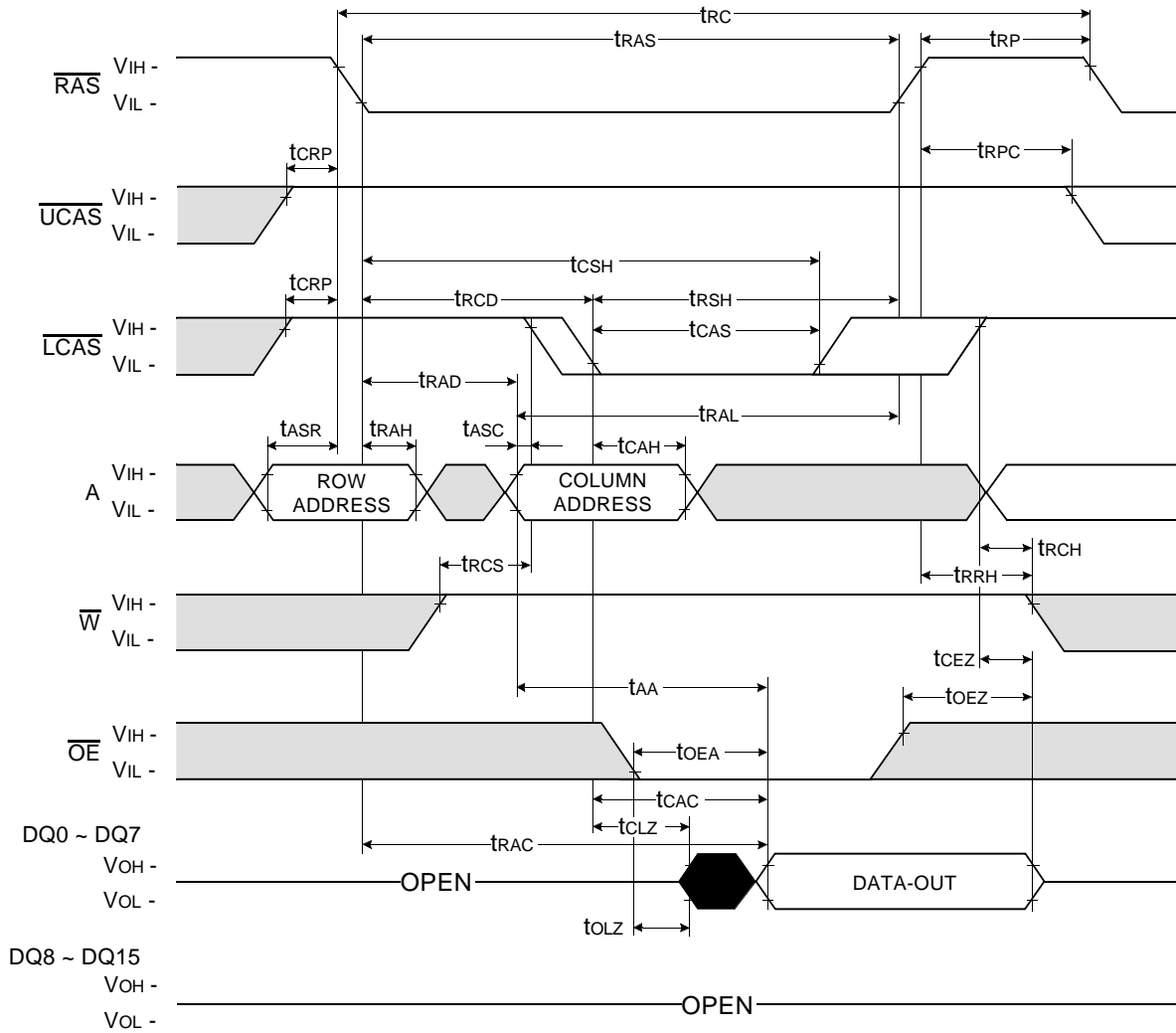

UPPER BYTE READ CYCLE

NOTE : DIN = OPEN

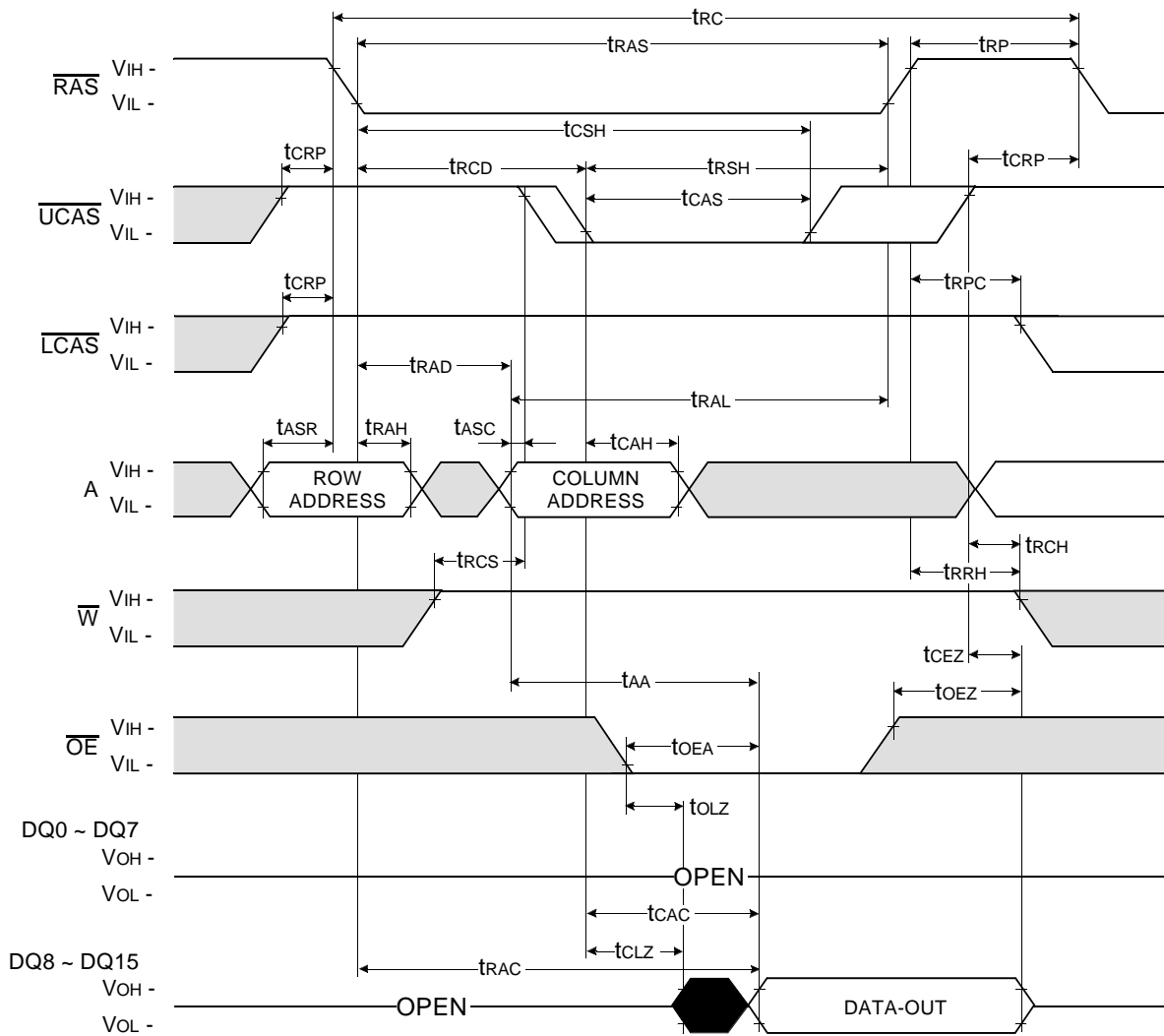

Don't care  
 Undefined

WORD WRITE CYCLE ( EARLY WRITE )

NOTE : DOUT = OPEN

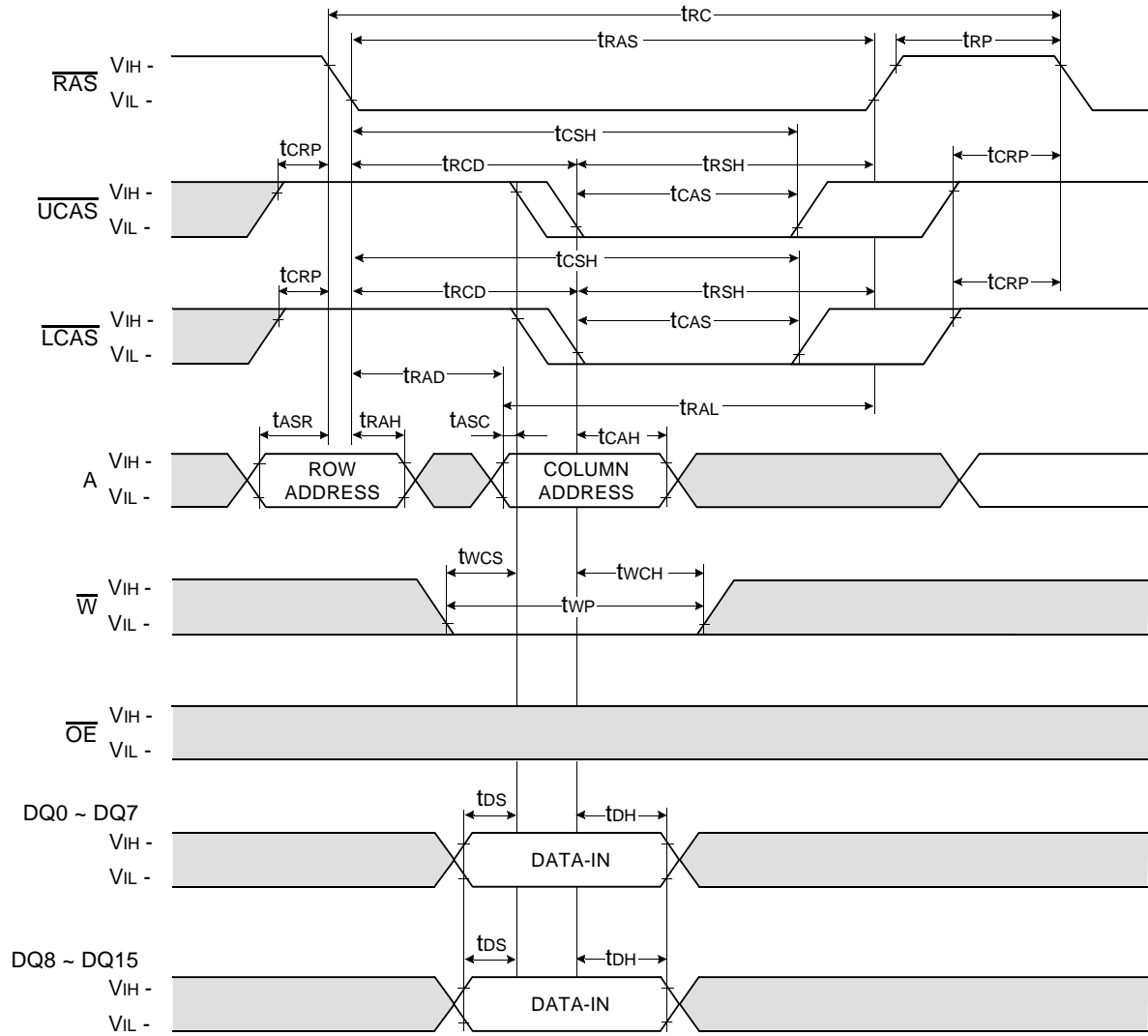

LOWER BYTE WRITE CYCLE ( EARLY WRITE )

NOTE : DOUT = OPEN

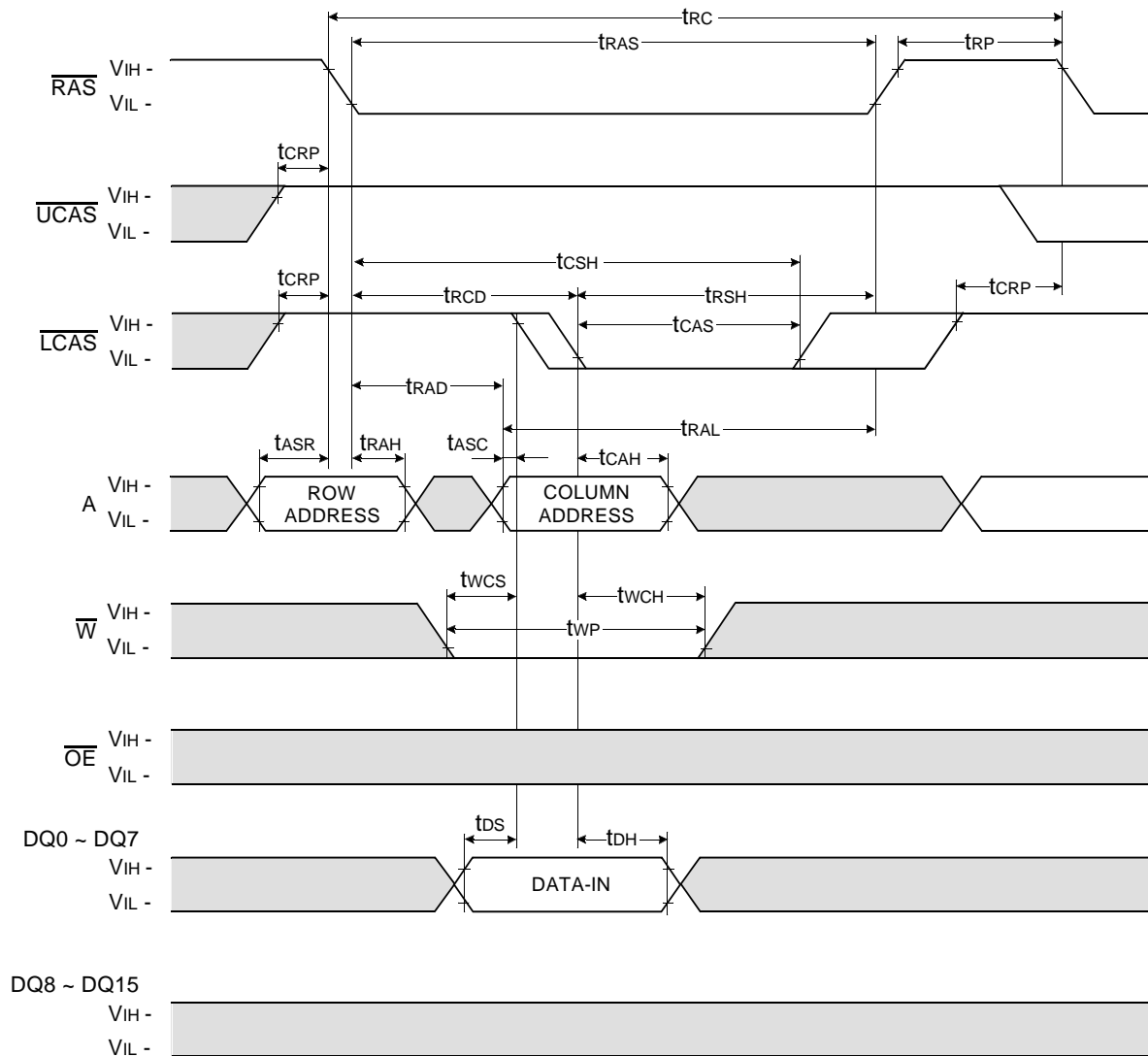

Don't care  
 Undefined

UPPER BYTE WRITE CYCLE ( EARLY WRITE )

NOTE : DOUT = OPEN

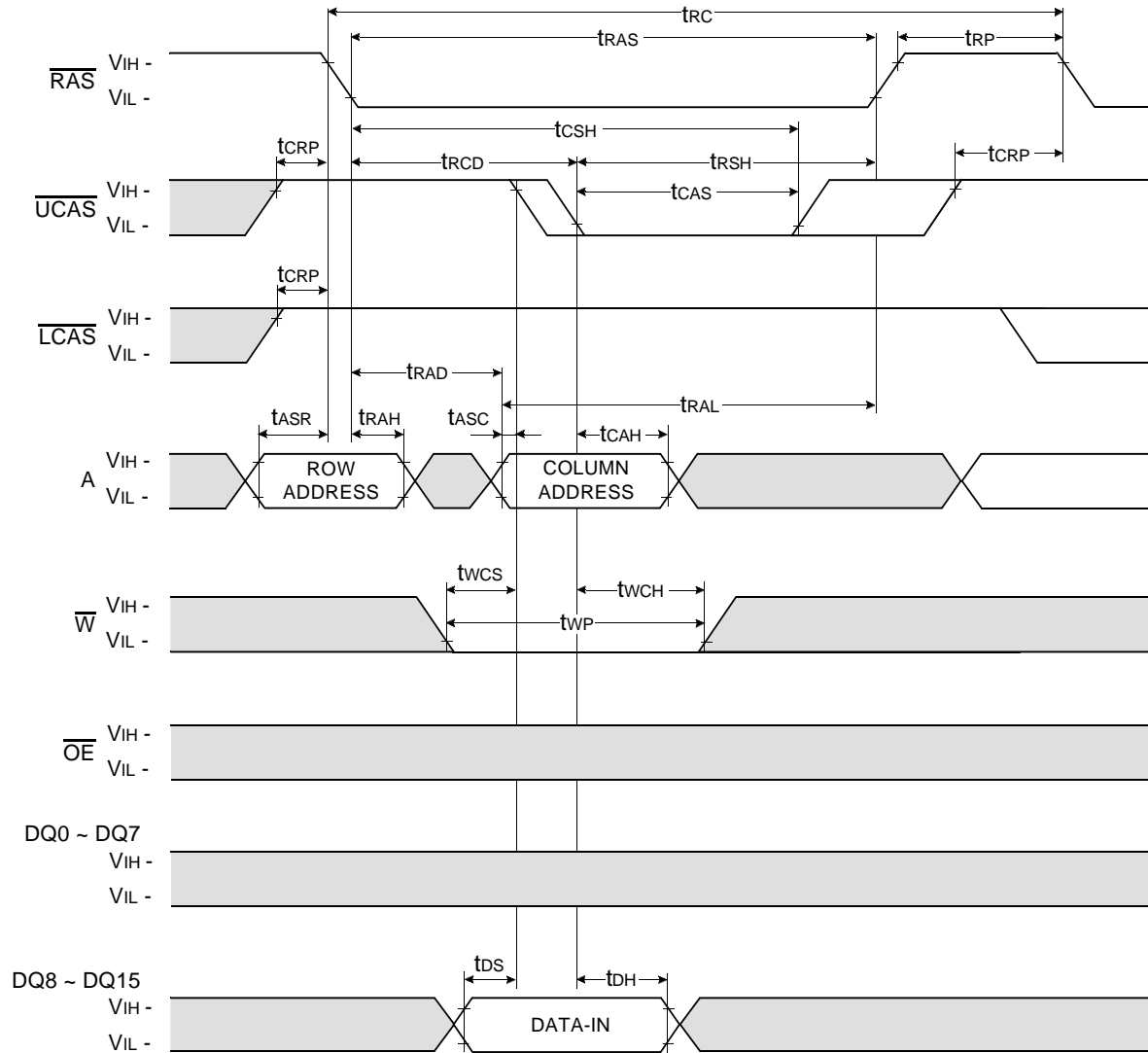

□ Don't care

■ Undefined

WORD WRITE CYCLE (  $\overline{OE}$  CONTROLLED WRITE )

NOTE : DOUT = OPEN

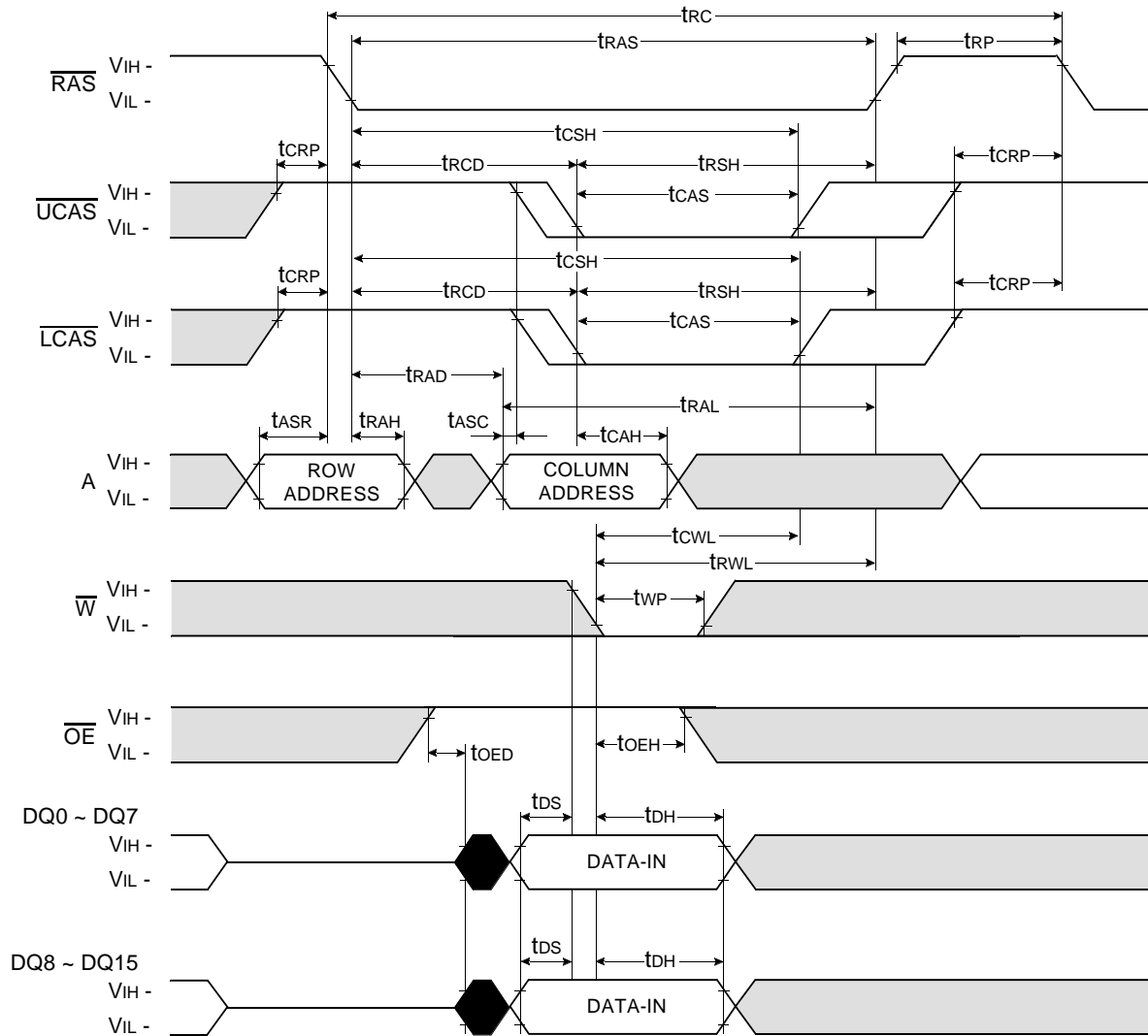

Don't care  
 Undefined





UPPER BYTE WRITE CYCLE (  $\overline{OE}$  CONTROLLED WRITE )

NOTE : DOUT = OPEN

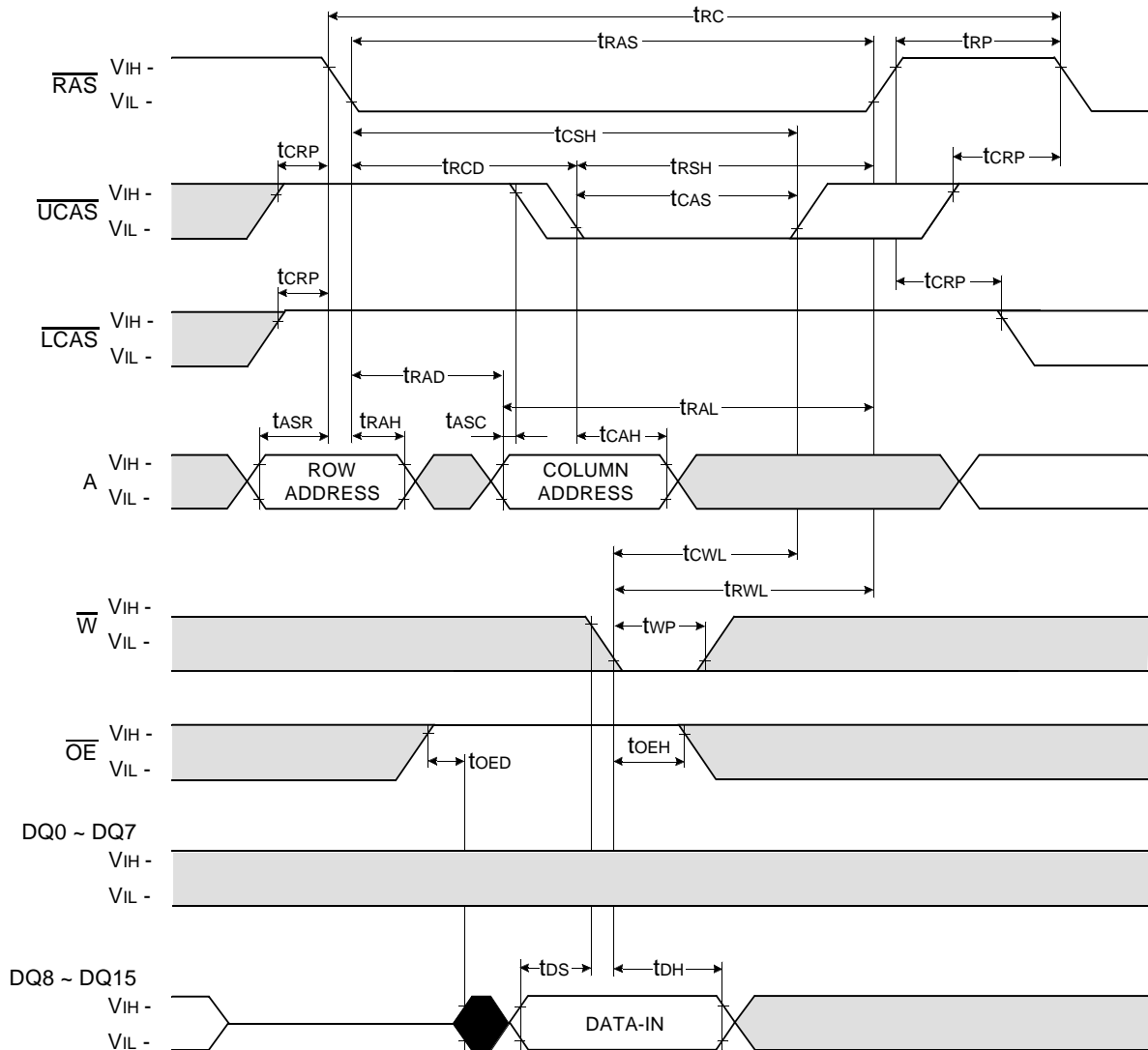

Don't care  
 Undefined

WORD READ - MODIFY - WRITE CYCLE

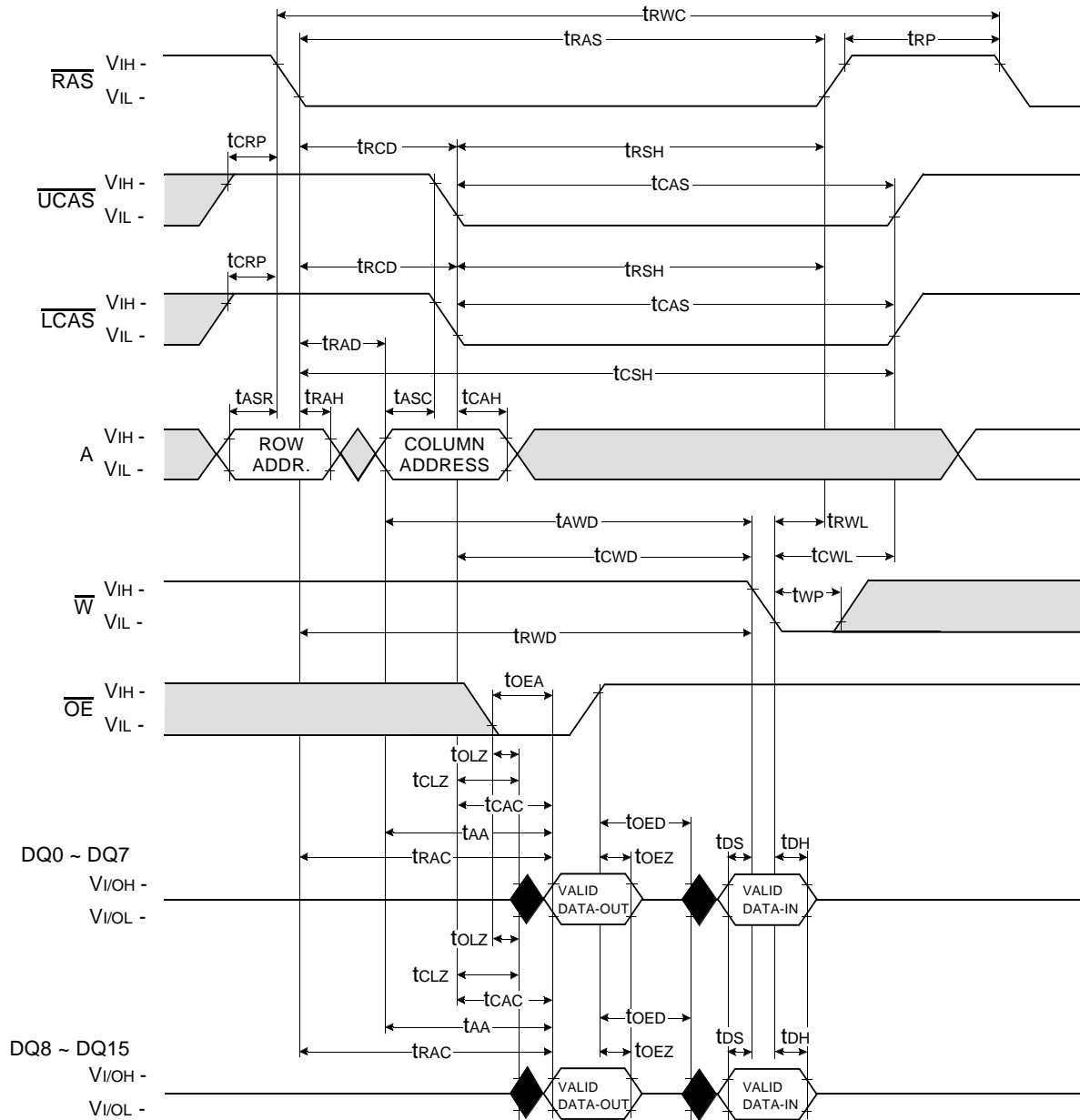

Don't care  
 Undefined

LOWER-BYTE READ - MODIFY - WRITE CYCLE

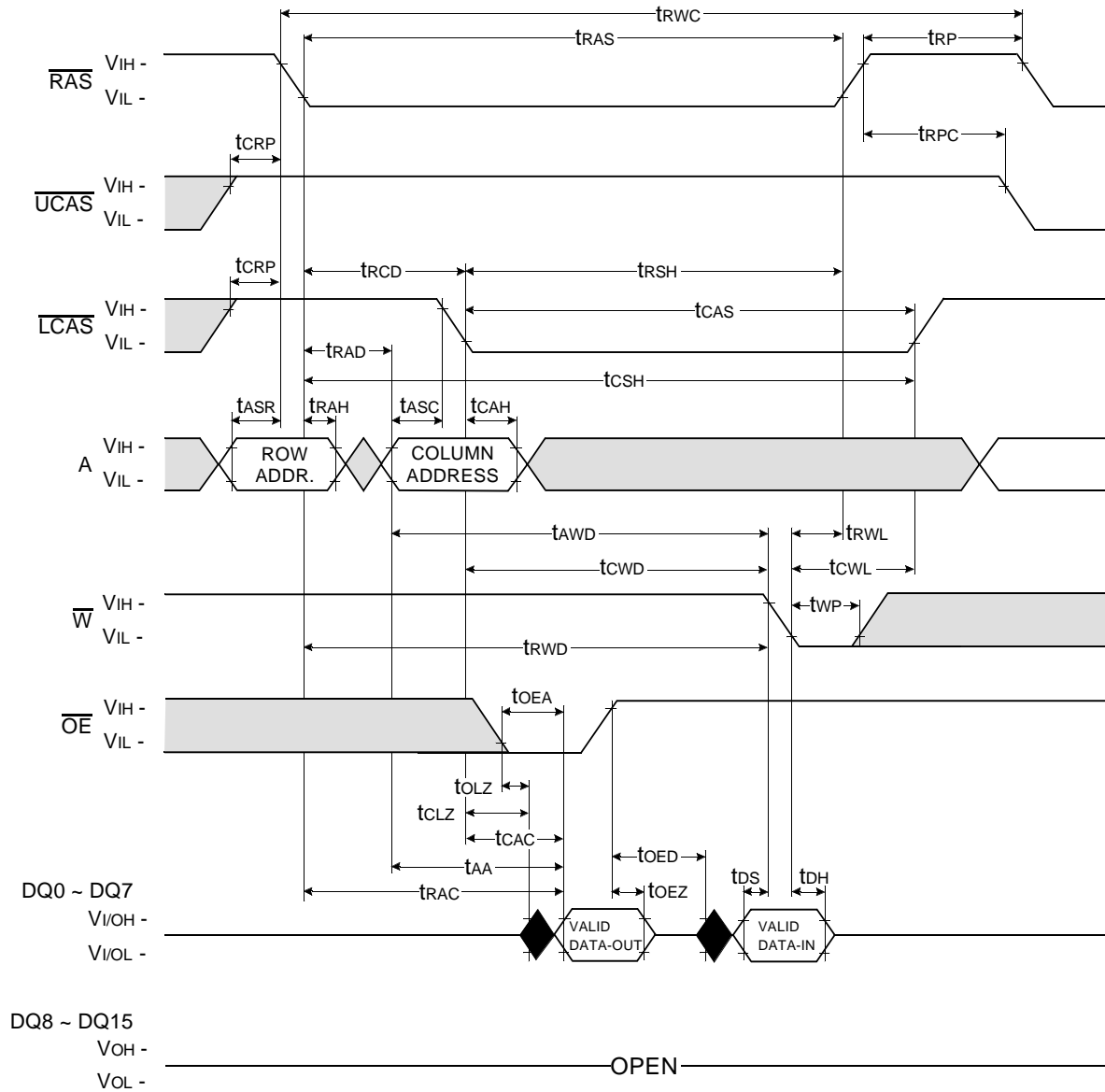

UPPER-BYTE READ - MODIFY - WRITE CYCLE

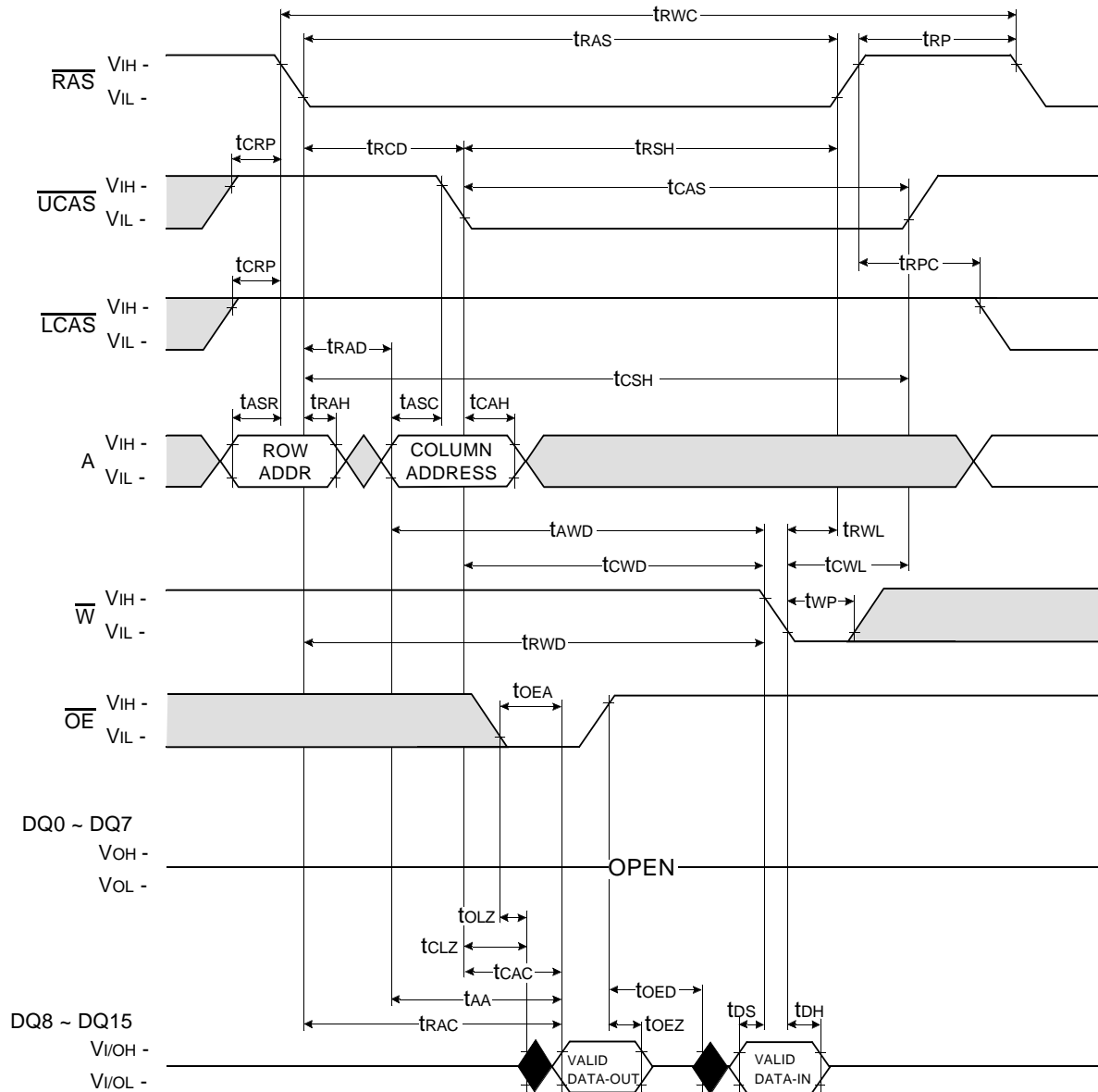

Don't care  
 Undefined





HYPER PAGE MODE UPPER BYTE READ CYCLE

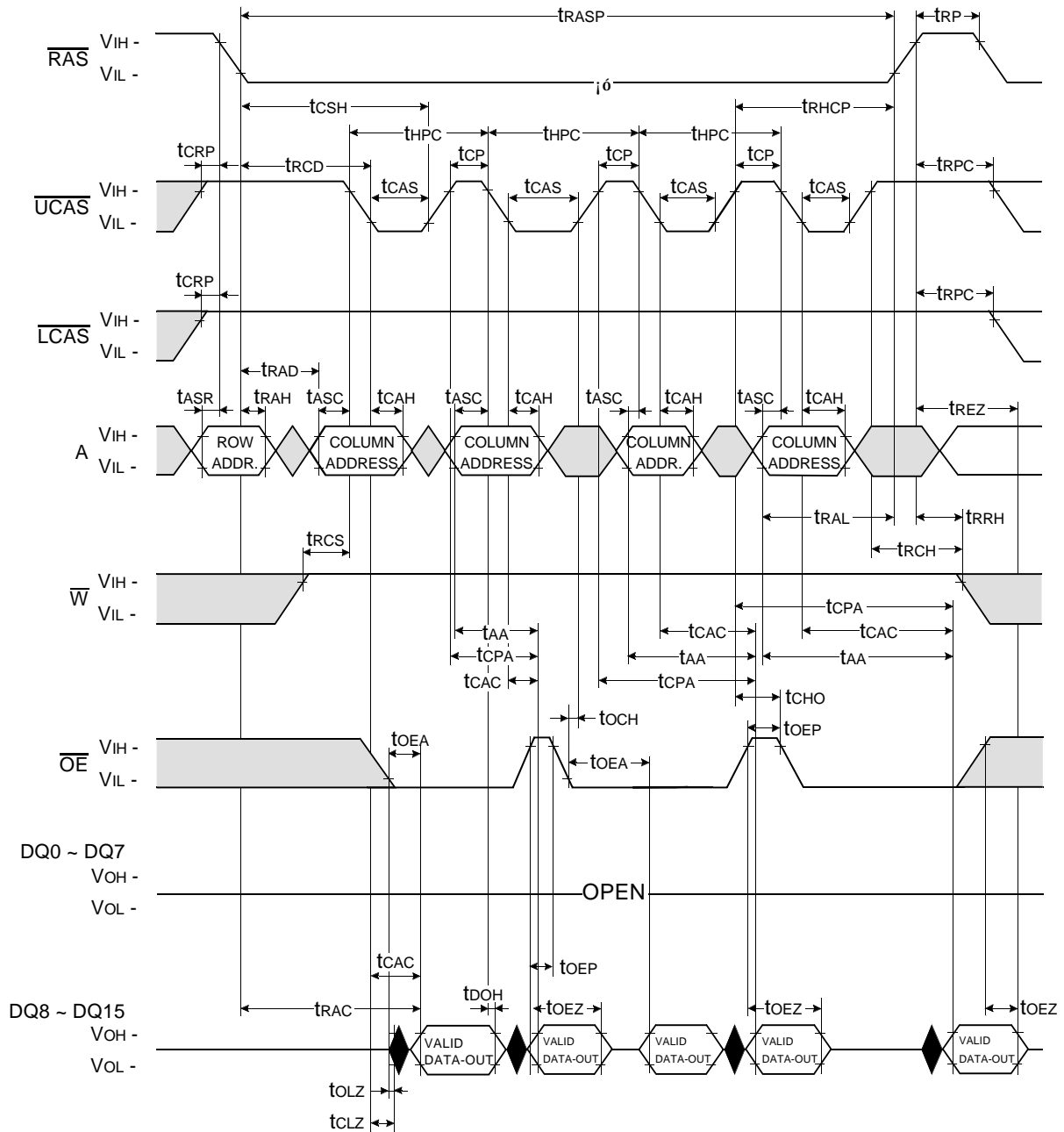

Don't care  
 Undefined



HYPER PAGE MODE WORD WRITE CYCLE ( EARLY WRITE )

NOTE : DOUT = OPEN

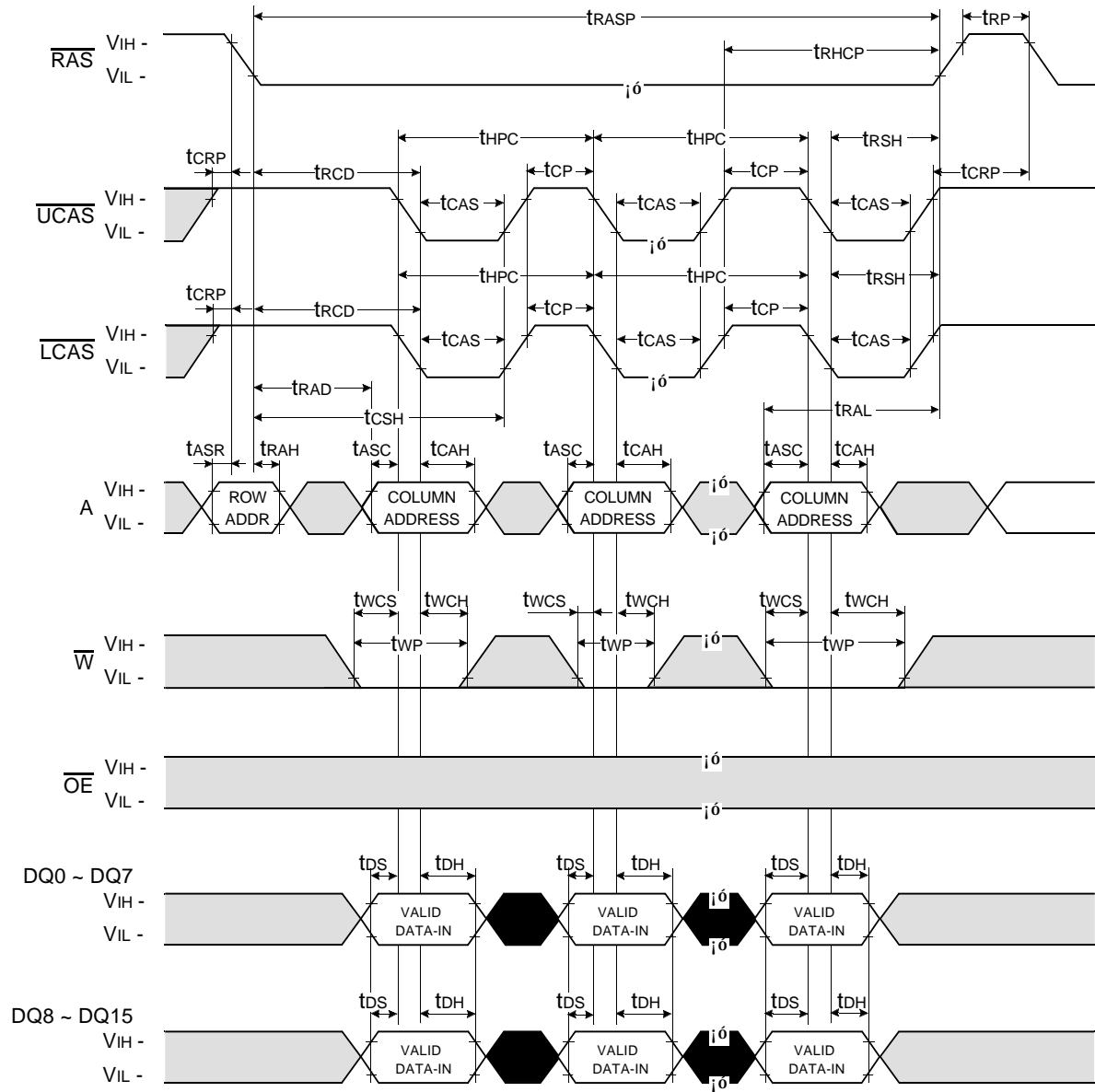

Don't care  
 Undefined

HYPER PAGE MODE LOWER BYTE WRITE CYCLE ( EARLY WRITE )

NOTE : DOUT = OPEN

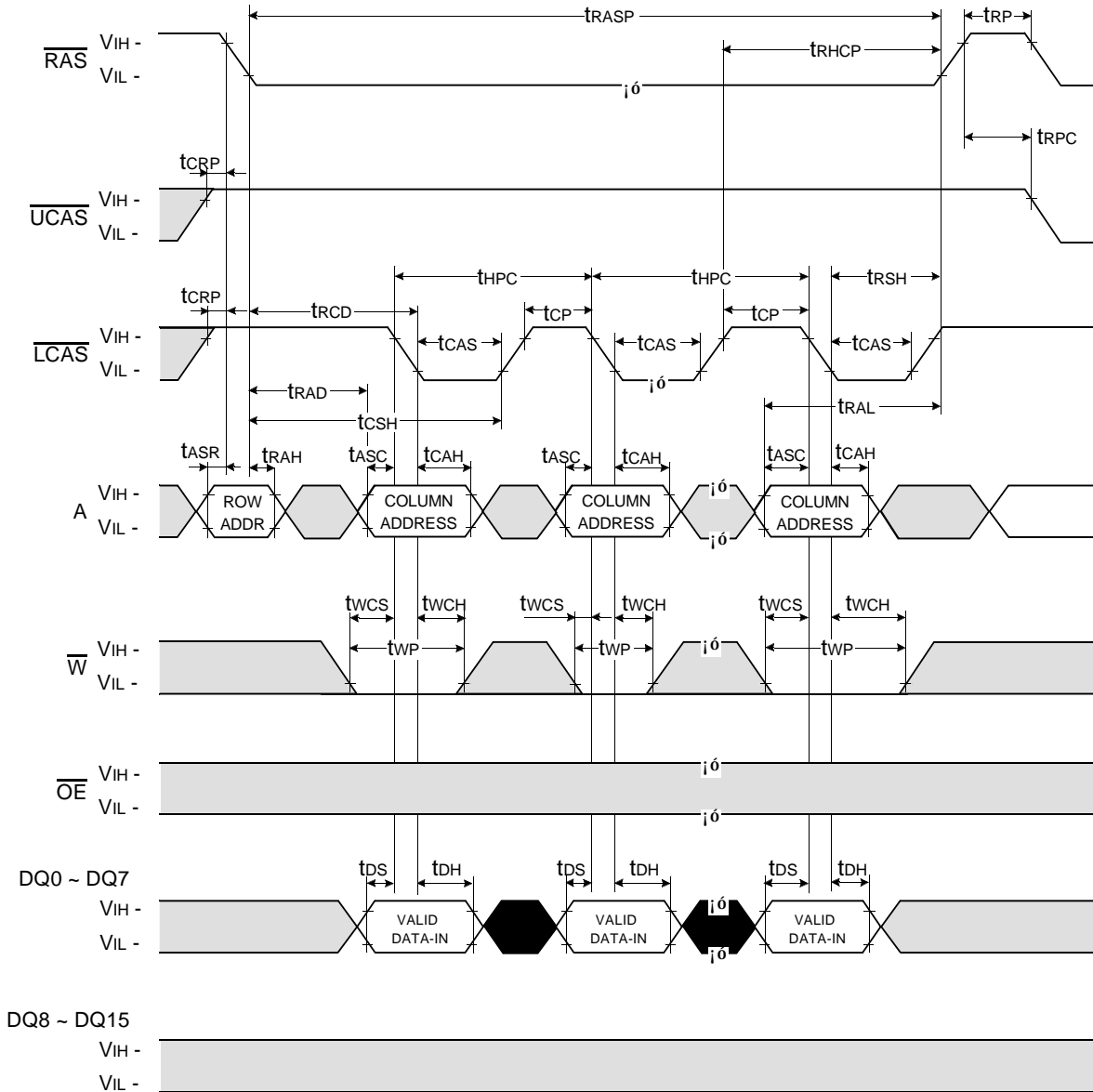

□ Don't care  
 ■ Undefined

HYPER PAGE MODE UPPER BYTE WRITE CYCLE ( EARLY WRITE )

NOTE : DOUT = OPEN

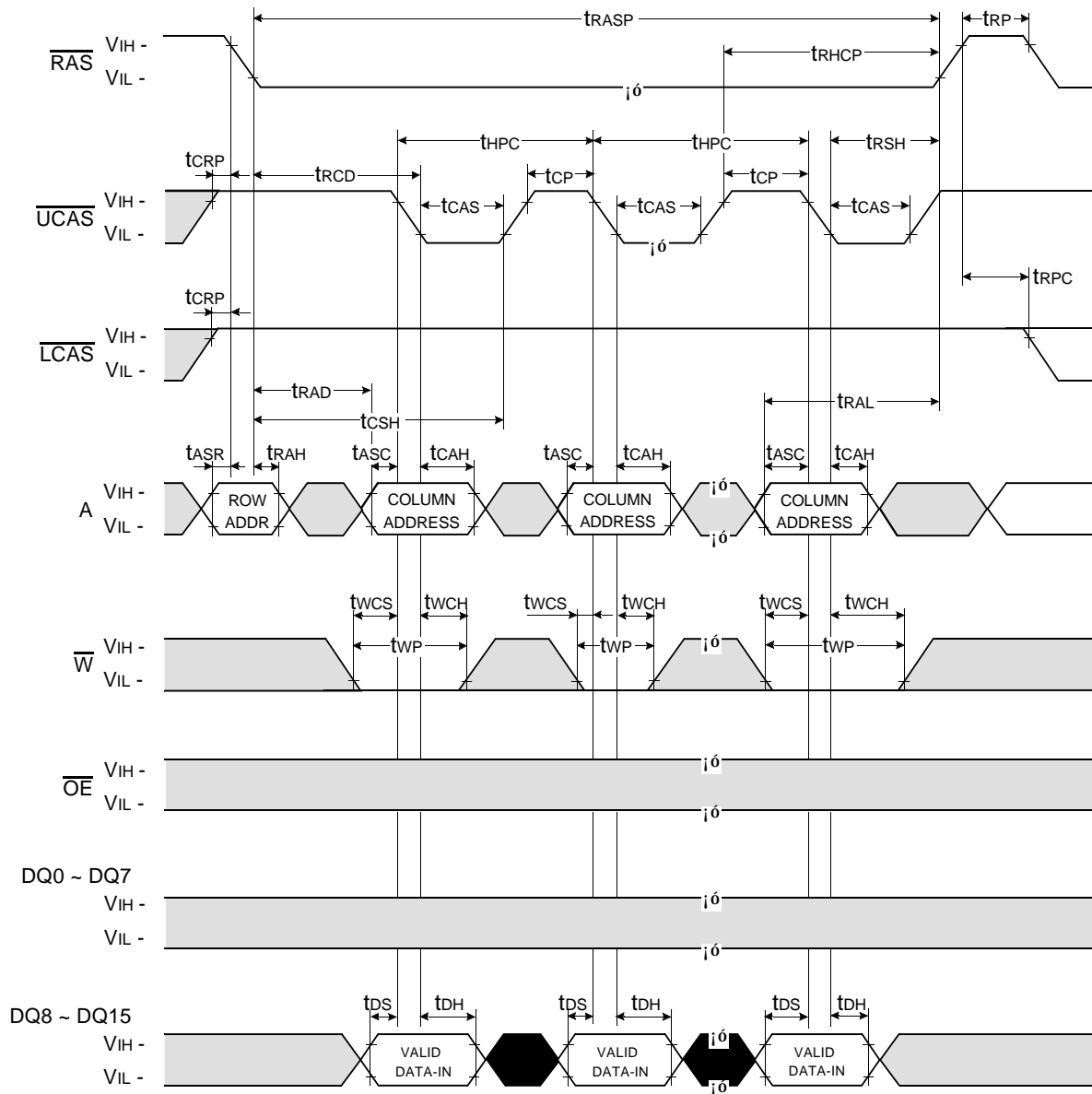

Don't care  
 Undefined





HYPER PAGE MODE UPPER BYTE READ - MODIFY - WRITE CYCLE

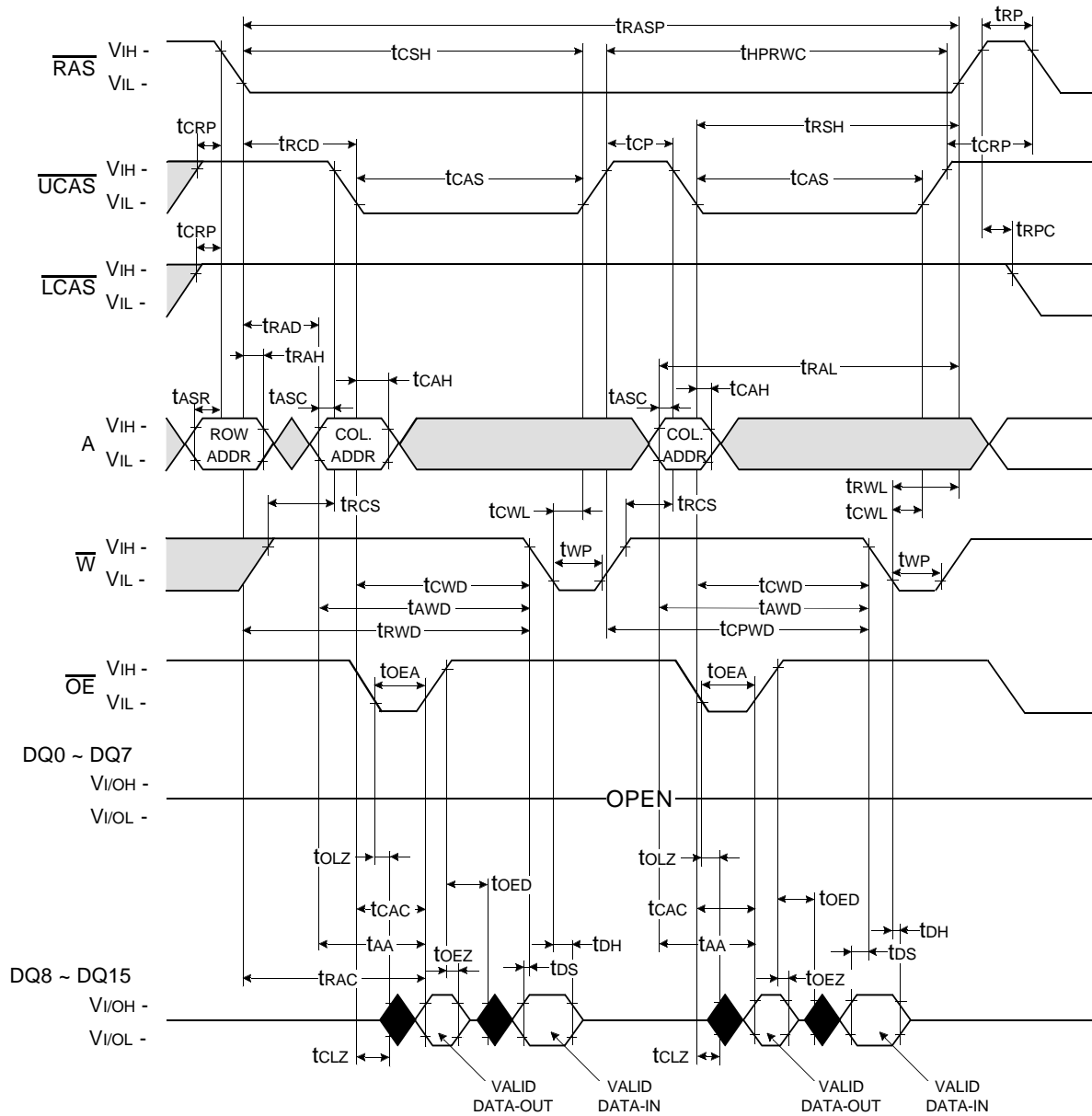

HYPER PAGE READ AND WRITE MIXED CYCLE

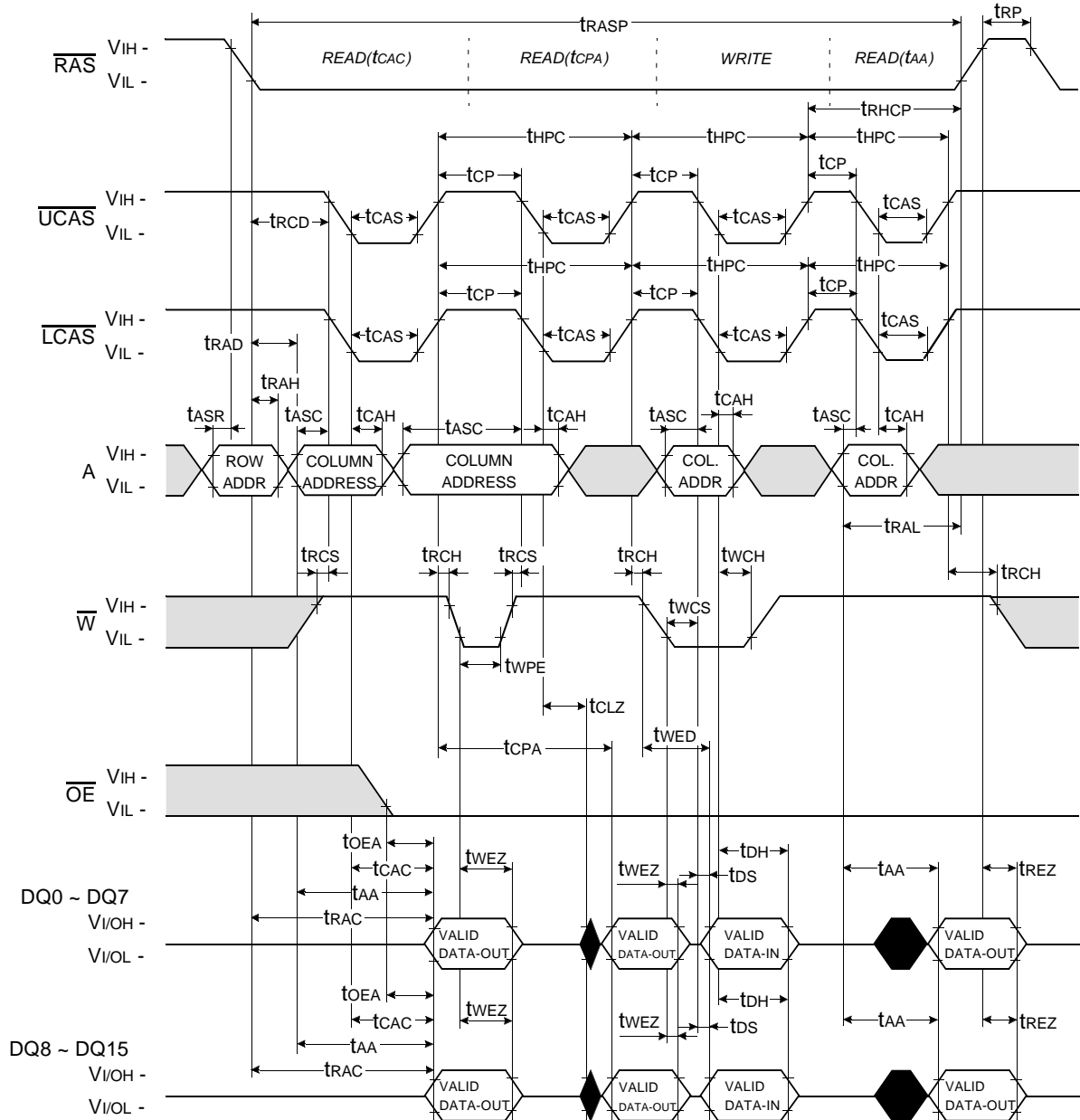

**$\overline{\text{RAS}}$  - ONLY REFRESH CYCLE**

NOTE :  $\overline{\text{W}}$ ,  $\overline{\text{OE}}$ , DIN = Don't care

DOUT = OPEN

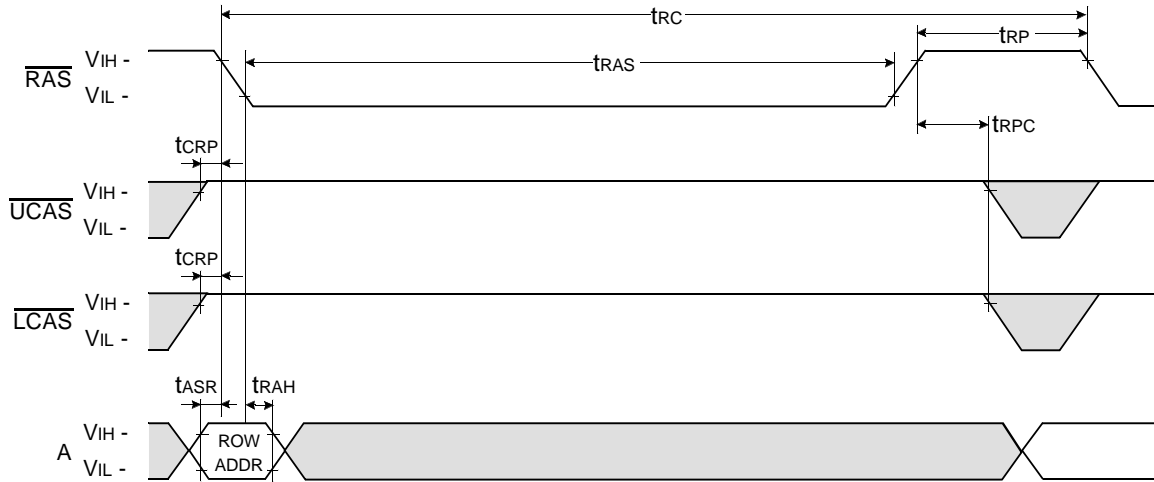

**$\overline{\text{CAS}}$  - BEFORE -  $\overline{\text{RAS}}$  REFRESH CYCLE**

NOTE :  $\overline{\text{OE}}$ , A = Don't care

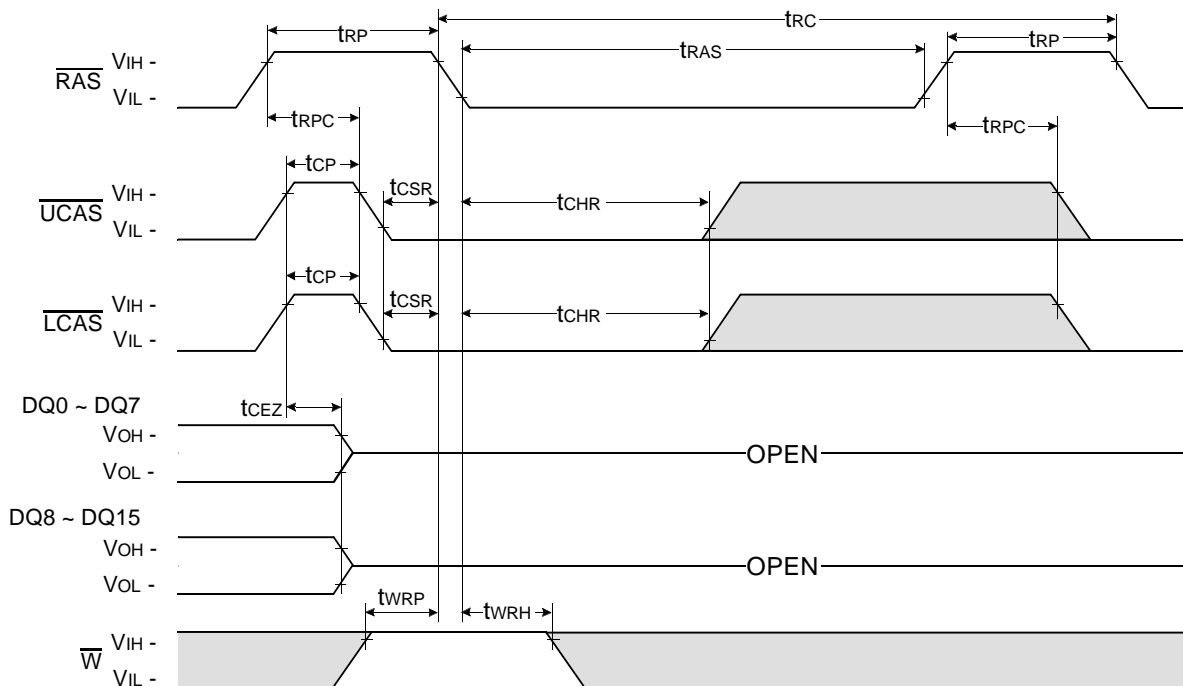

Don't care  
 Undefined



HIDDEN REFRESH CYCLE ( READ )

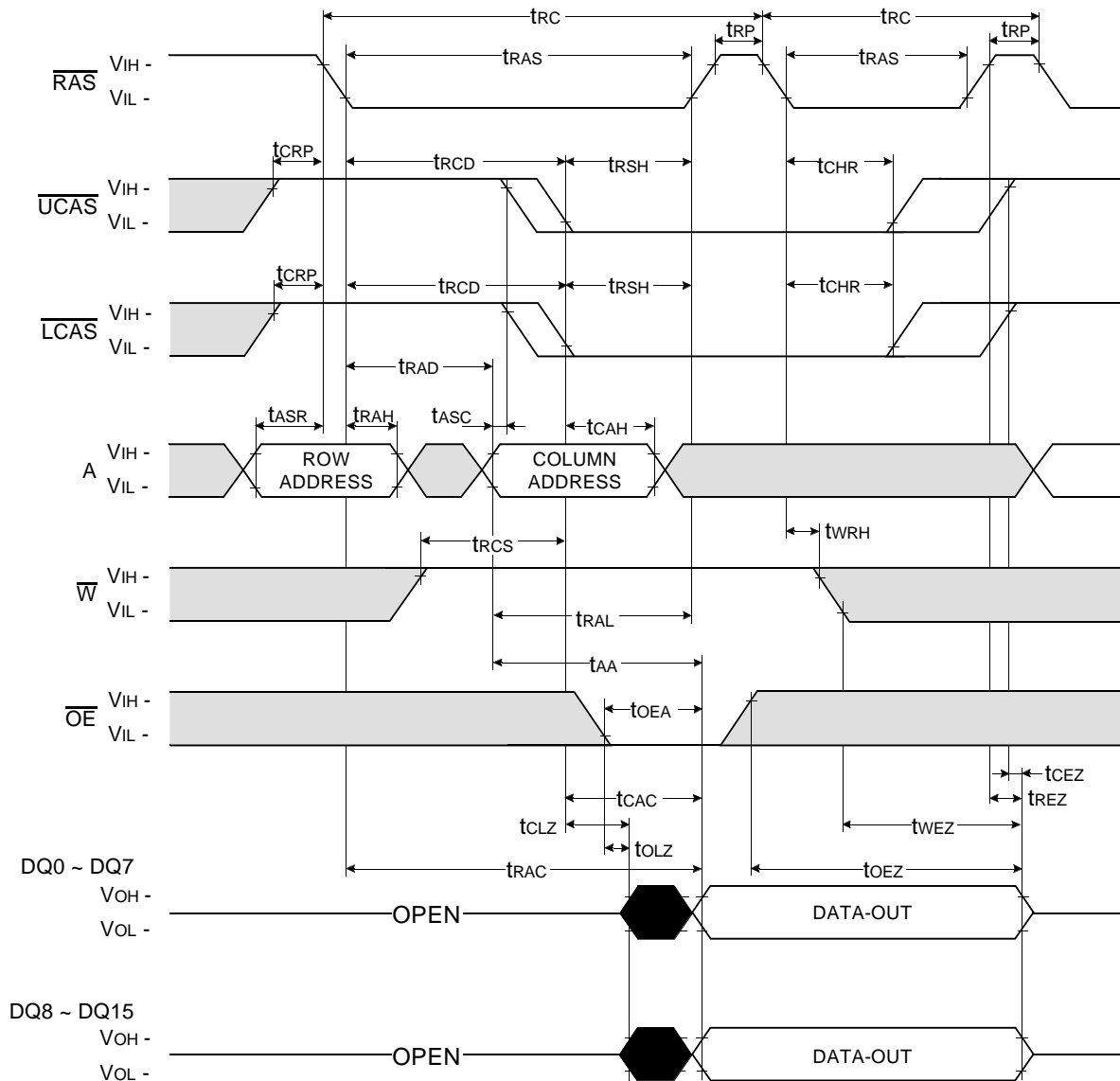

Don't care  
 Undefined

\* In Hidden refresh cycle of 64Mb A-die & B-die, when  $\overline{CAS}$  signal transits from Low to High, the valid data may be cut off.

**HIDDEN REFRESH CYCLE ( WRITE )**

NOTE : DOUT = OPEN

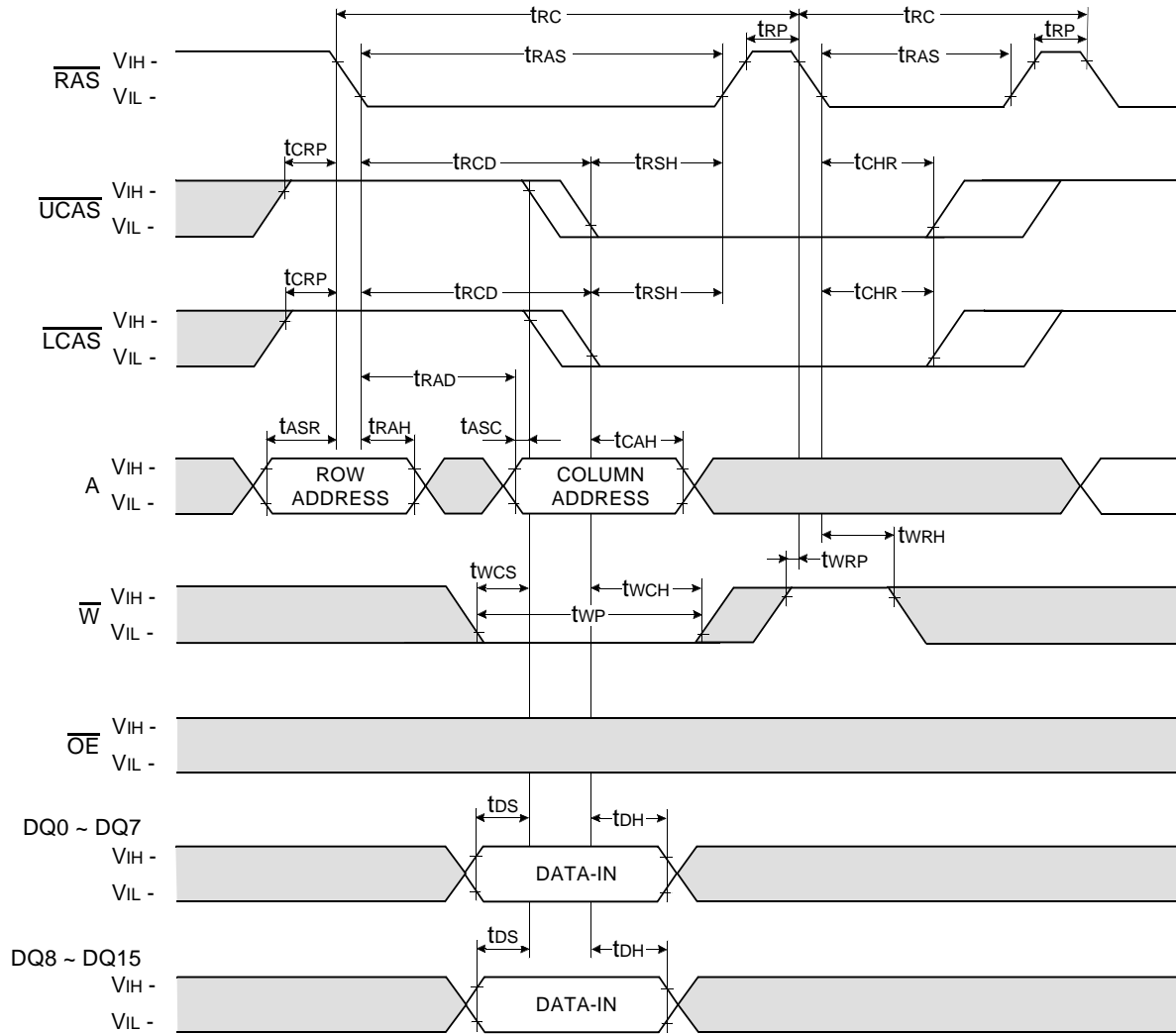

□ Don't care  
 ■ Undefined

**CAS - BEFORE - RAS SELF REFRESH CYCLE**

NOTE :  $\overline{OE}$ , A = Don't care

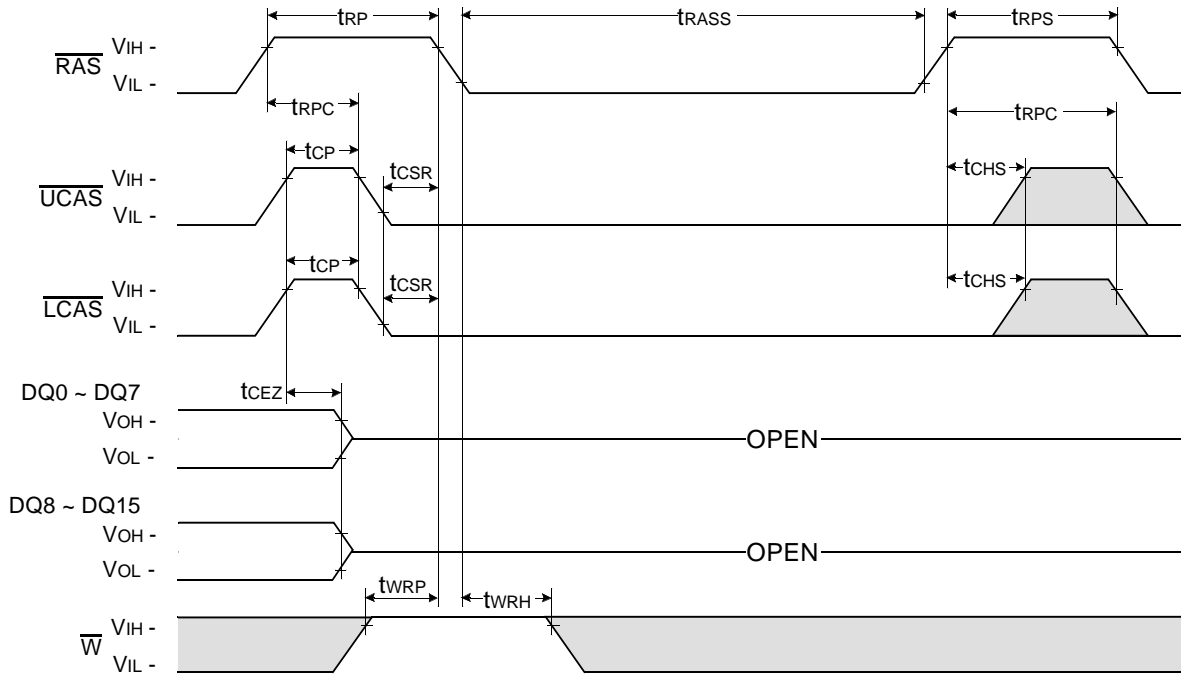

**TEST MODE IN CYCLE**

NOTE :  $\overline{OE}$ , A = Don't care

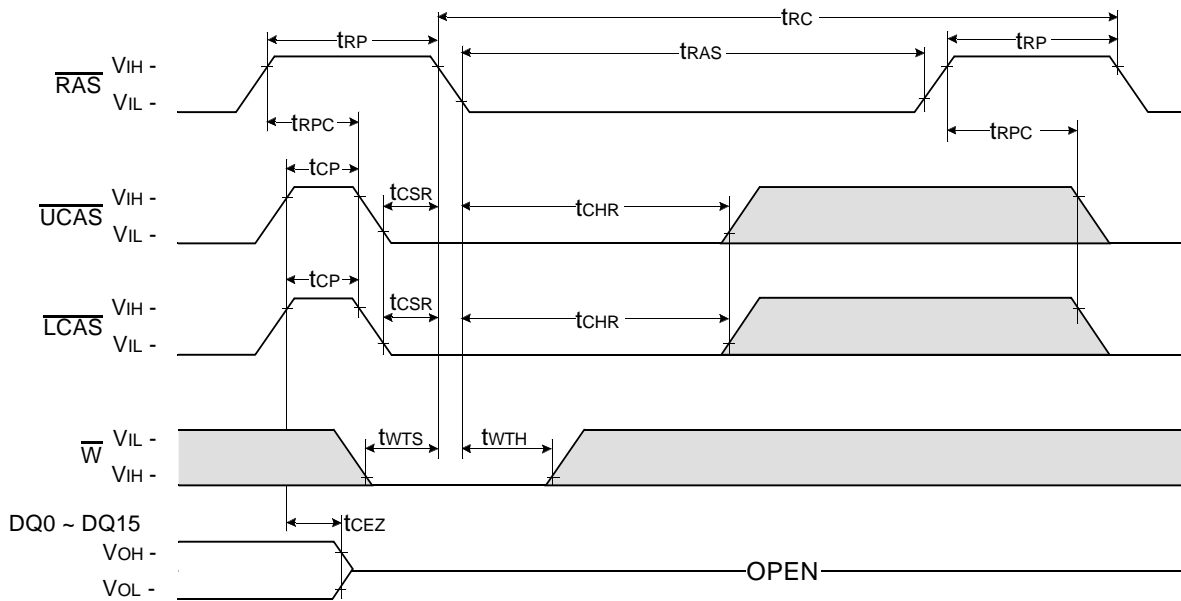

□ Don't care  
 ■ Undefined

PACKAGE DIMENSION

