



SK70740/44

HDSL2 Modem Chip Set

Datasheet

The SK70740 and SK70744 chip set provide full-duplex, T1 (DS-1) transmission over a single twisted pair. The chip set is capable of providing Overlapped PAM Transmission with Interlocking Spectra (OPTIS) power spectral density (PSD). The chip set consists of two ICs that provide the HDSL2 modem solution:

- SK70740HE - Analog Front End (AFE)
- SK70744HE - Transceiver/Framer

The SK70740 AFE is separated into a transmit and receive channel. In the transmit channel, the AFE receives a pulse width modulated data stream from the digital transceiver. Switched capacitor filters shape the transmitted signal to suppress out-of-band noise. The receive channel consists of an automatic gain control (AGC) stage and an analog to digital (A/D) converter. The dynamic range of the receive channel is over 80 dB.

The core of the SK70744 Transceiver/Framer is a Trellis Coded PAM modulator/demodulator. HDSL2 utilizes shaped PAM-16 modulation to minimize interference into other services. The transmit filter can be programmed through firmware, allowing the transmit power spectrum to be optimized for the regional conditions. In addition, Trellis Coding (TC) and Viterbi Decoding, allows the system to provide high signal to noise margin in the presence of crosstalk noise from other services.

The frame mapping function inserts and recovers the HDSL2 overhead. Interrupt alarms are provided for loss of sync and CRC errors. The system also has read/write register access to the Embedded Operations Channel (EOC) bits within the HDSL2 frame. A synchronous data interface allows use with common T1 framers.

Applications

- T1 transport systems
- Multi-channel digital pair gain systems
- WAN access for LAN routers and switches
- Integrated access devices
- Wireless access systems

Product Features

- Supports ANSI T1E1.418 (HDSL2) specification
- Programmable for either Central Office (H2TU-C) or Remote (H2TU-R) applications
- Operates from a single crystal reference
- High resolution, Delta-Sigma A/D converter
- I/O operates at 3.3 V logic levels and is 5V tolerant
- Intel/Motorola compatible 8-bit microprocessor interface allows rapid setup, acquisition and status monitoring
- Programmable activation controller minimizes load on the system processor
- Internal circuitry for wander reduction



Information in this document is provided in connection with Intel® products. No license, express or implied, by estoppel or otherwise, to any intellectual property rights is granted by this document. Except as provided in Intel's Terms and Conditions of Sale for such products, Intel assumes no liability whatsoever, and Intel disclaims any express or implied warranty, relating to sale and/or use of Intel products including liability or warranties relating to fitness for a particular purpose, merchantability, or infringement of any patent, copyright or other intellectual property right. Intel products are not intended for use in medical, life saving, or life sustaining applications.

Intel may make changes to specifications and product descriptions at any time, without notice.

Designers must not rely on the absence or characteristics of any features or instructions marked "reserved" or "undefined." Intel reserves these for future definition and shall have no responsibility whatsoever for conflicts or incompatibilities arising from future changes to them.

The SK70740/44 may contain design defects or errors known as errata which may cause the product to deviate from published specifications. Current characterized errata are available on request.

Contact your local Intel sales office or your distributor to obtain the latest specifications and before placing your product order.

Copies of documents which have an ordering number and are referenced in this document, or other Intel literature may be obtained by calling 1-800-548-4725 or by visiting Intel's website at <http://www.intel.com>.

Copyright © Intel Corporation, 2001

*Third-party brands and names are the property of their respective owners.

Contents

1.0	Pin Assignments and Signal Descriptions	10
2.0	General Functional Description	19
2.1	Overview	19
2.2	Transceiver-AFE Interfaces.....	20
2.2.1	Data Interface	20
2.2.2	Control Interface.....	20
2.3	JTAG Interface	20
3.0	AFE Functional Description	22
3.1	Upstream and Downstream Spectrums	22
3.2	Transmitter	23
3.3	Receiver	23
3.4	Line Interface.....	24
3.5	Reference Clock.....	25
3.6	Loopbacks	25
4.0	Transceiver/Framer Functional Description	26
4.1	TDM Interface.....	26
4.1.1	T1 Transport Operation	26
4.2	T1 Frame Mapping	26
4.2.1	Transmit Frame Mapping	27
4.2.2	Receive Frame Mapping	31
4.3	Frame Synchronization	32
4.4	Forward Error Correction (FEC)	34
4.4.1	FEC Encoder	34
4.4.2	FEC Decoder.....	35
4.5	PAM Transmitter	35
4.6	Receiver	36
4.7	Clock Generation.....	37
4.8	Noise Margin and SNR Estimation.....	37
4.9	Activation.....	38
4.9.1	Pre-Activation	38
4.9.2	Primary Activation	39
4.9.3	Inactive State.....	41
4.9.4	Activating State	41
4.9.5	Active State	41
4.9.6	FSTAT	41
4.9.7	Hold (Pending) State	41
4.9.8	Deactivated State	41
4.9.9	Activating State Machine.....	42
4.10	Activation Frame	43
4.11	Power Down	45
4.12	Loopbacks	45
4.13	Microprocessor Interface.....	46

5.0	Register Definitions	47
5.1	AFE Registers	47
5.2	Transceiver/Framer Registers.....	49
5.3	PAM Transceiver Registers	51
5.3.1	Registers 03h through 09h are Reserved	52
5.3.2	Registers 0Fh through 17h are Reserved	54
5.3.3	Registers 1Bh through 21h are Reserved.....	54
5.3.4	Registers 23h and 24h are Reserved	54
5.3.5	Registers 26h through 2Ch are Reserved.....	55
5.3.6	Registers 34h through 7Fh are Reserved	56
5.4	FEC Registers.....	56
5.4.1	FEC Encoder/Decoder Configuration Registers.....	56
5.4.2	FEC Noise Register	57
5.4.3	Registers 86h through 92h are Reserved	58
5.4.4	Registers 94h through 9Fh are Reserved	58
5.5	Framer Transmit Registers	58
5.5.1	Registers ABh through B0h are Reserved	62
5.6	Framer Receive Registers	63
5.6.1	Receive FIFO Water Level.....	64
5.6.2	PLL Synthesizer Registers.....	65
5.6.3	Registers CCh through D1h are Reserved.....	67
5.6.4	Registers D6h through DCh are Reserved.....	68
5.6.5	Registers DF through FF are Reserved	68
6.0	Analog Front End Test Specifications	69
7.0	Transceiver/Framer Test Specifications	72
8.0	Mechanical Specifications	78

Figures

1	SK70740/44 Block Diagram	9
2	Analog Front End Pin Assignments	10
3	Transceiver/Framer Pin Assignments	14
4	HDSL2 Modem.....	19
5	Transceiver/AFE Control Interface Data Structure.....	21
6	Transmit Frequency Response	23
7	Line Interface Network	24
8	Loopback Data Paths.....	25
9	Relative Timing for TDM Interface in T1 Transport Mode	28
10	Transmit Framer Block Diagram	28
11	HDSL2 Frame Format for T1 Payload	29
12	Receive Framer Block Diagram	32
13	Frame Synchronization Operation	33
14	FEC Encoder and Symbol Mapping.....	34
15	Convolutional Encoder	35
16	FEC Decoder Block Diagram	35
17	HDSL2 PSD Mask for North America	36
18	Clock Generation	37

19	Simplified State Transition at Activation	40
20	Start-Up Sequence	44
21	System Loopback Options	46
22	RCLK Generation Circuit.....	66
23	AFE Interface Timing.....	71
24	AFE Data Interface Relative Timing	73
25	AFE Control Interface Relative Timing	74
26	TDM Interface Timing - T1 Transport Mode	75
27	Parallel Microprocessor Bus Interface Timing.....	77
28	64 Pin QFP Package.....	78
29	100 Pin QFP Package.....	79

Tables

1	SK70740 Analog Front End Signal Descriptions	11
2	SK70744 Transceiver/Framer Signal Descriptions	15
3	HDSL2 Frame Structure for T1	29
4	HDSL2 Overhead Bit to Register Mapping.....	30
5	Pre-Activation Frame.....	38
6	Start-up Timers.....	42
7	Activation Frame Format (Optional)	45
8	AFE Control Register 1, AR1, R/W, Address = 00h, Default = 00h.....	47
9	AFE Control Register 2, AR2, R/W, Address = 01h, Default = 00h.....	48
10	Transceiver/Framer Register Categories	49
11	Transceiver/Framer Register Summary	49
12	Main Control Register 0, MAIN0, R/W, Address = 00h, Default = 00h.....	51
13	Main Control Register 1, MAIN1, R/W Address = 01h, Default = 20h.....	52
14	Activation Mode Control Register, ACT_MODE, R/W, Address = 02h, Default = 00h	52
15	AFE Control Register, AFE_CTL, R/W, Address 0Ah, Default = FFh	52
16	AFE Address Register, AFE_ADD1, R/W, Address = 0Bh, Default = 80h	52
17	Interrupt Mask Register, INT_MSK1, R/W, Address = 0Ch, Default = FFh.....	53
18	Interrupt State Register, INT_ST1, R/W, Address = 0Dh, Default = 00h	53
19	Hardware Configuration Register, HW_CFG, R, Address = 0Eh, Default = F0h.....	53
20	Rate Select 0 Register, RATE_SEL0, R/W, Address = 18h, Default = AAh	54
21	Rate Select 1 Register, RATE_SEL1, R/W, Address = 19h, Default = AAh	54
22	Rate Select 2 Register, RATE_SEL2, R/W, Address = 1Ah, Default = ABh	54
23	TIP/RING Reversal, TIP/RING, R, Address = 22h, Default = 00h.....	54
24	Framer Status Register, FSTAT, R/W, Address = 25h, Default = 00h	54
25	AFE Status Register, AFE_STAT, R/W, Address = 2Dh, Default = 00h	55
26	Soft Decision (LSB) Register, SFT0, R, Address = 2Eh, Default = 00 h	55
27	Soft Decision (MSB) Register, SFT1, R, Address = 2Fh, Default = 00h	55
28	PLL Control Register, PLL_CTL, R/W, Address = 30h, Default = 00h	55
29	Main Control Register 2, MAIN2, R/W, Address = 31h, Default = 01h.....	55
30	Miscellaneous Control Register 1, MISC1, R/W, Address = 32h, Default = 00h.....	56
31	Wander Reduction Control Register, HTMCR, R/W, Address = 33h, Default = 00h	56
32	Code Generator Select, CGSEL, R/W, Address = 80h, Default = 00h.....	56

33	Code Generator 1, CG1, R/W, Address = 81h, Default = DAh	57
34	Code Generator 2, CG2, R/W, Address = 82h Default = CDh	57
35	Code Generator 3, CG3, R/W, Address = 83h, Default = 08h	57
36	FEC Trace Back, FECTB, R/W, Address = 84h, Default = 00h	57
37	FEC Noise, FECNS, R, Address = 85h.....	58
38	FEC Control, FECCR, R/W, Address = 93h, Default = 00h	58
39	Framer Payload Rate, PLRATE, R/W, Address = A0h, Default = 18h.....	58
40	Reference Transmit Water Level, HTFWL, R/W, Address = A1h, Default = 2Eh	59
41	Actual Transmit Water Level, TFWL, R, Address = A2h.....	59
42	Transmit Control Register, HTFCR, R/W, Address = A3h, Default = 08h.....	59
43	Transmit Test Control Register, HTFTCR, R/W, Address = A4h, Default = 00h.....	59
44	Transmit Data Byte Selection Register, HTFBSR, R/W, Address = A5h, Default = 00.....	60
45	Data Read Sample (High) Register, HTFRSRH, R, Address = A6h	60
46	Data Read Sample (Low) Register, HTFRSRL, R, Address = A7h.....	60
47	Transmit Frame Control Register, HTFTMR, R/W, Address = A8h, Default = 00h.....	60
48	All 1's / 0's Control	61
49	Transmit Sync Word (First 8 bits), HTFFSW1, R/W, Address = A9h Default = 00h.....	61
50	Transmit Sync Word (Last 2 bits), HTFFSW2, R/W, Address = AAh Default = 00h.....	61
51	HDSL2 Transmit Overhead Register 1, HTFHOH1, R/W, Address = B1h, Default = 00h.....	62
52	HDSL2 Transmit Overhead Register 2, HTFHOH2, R/W, Address=B2h, Default=00h.....	62
53	HDSL2 Transmit Overhead Register 3, HTFHOH3, R/W, Address = B3h, Default = 00h.....	62
54	HDSL2 Transmit Overhead Register 4, HTFHOH4, R/W, Address = B4h, Default = 00h.....	63
55	Receive Control Register, HRFCR, R/W, Address = C0h, Default 00h	63
56	Receive Test Control Register, HRFTCR, R/W, Address = C1h, Default = 00h.....	64
57	Receive FIFO Water Level Register, HRFWL, R, Address = C2h	64
58	FIFO Depth Register, HRFFDR, R, Address = C3h.....	64
59	Receive Status Register, HRFSR Register, R, Address = C4h	65
60	Receive Timing & Loopback Register, HRFTTCR, R/W, Address = C5h, Default = 00h.....	65
61	NCO Control Register (MSB), HRFNCR1, R/W, Address = C6h, Default = 17h.....	66
62	NCO Control Register (LSB), HRFNCR2, R/W, Address = C7h, Default = 5Ah	66
63	DPLL Phase Adjustment Register, HRFP AJ, R/W, Address = CAh, Default = 2Ch	66
64	DPLL Clock Division Ratio, HRFPAC, R/W, Address = CBh, Default =15h.....	66
65	CRC Counter Register, HRF CRC, R, Address = C9h.....	67
66	HDSL2 Receive Overhead Register 1, HRFHOH1, R, Address = D2h.....	67
67	HDSL2 Receive Overhead Register 2, HRFHOH2, R, Address = D3h.....	67
68	HDSL2 Receive Overhead Register 3, HRFHOH3, R, Address = D4h.....	67

69	HDSL2 Receive Overhead Register 4, HRFHOH4, R, Address = D5h.....	68
70	Receive Frame Sync Word (First 8 bits), HRFFSW1, R/W, Address = DDh, Default = 00h.....	68
71	Receive Frame Sync Word & Stuff Bits, HRFFSWSB, R/W, Address = DEh, Default = 00h.....	68
72	Absolute Maximum Ratings.....	69
73	Recommended Operating Conditions	69
74	DC Electrical Characteristics.....	69
75	Transmitter Electrical Parameters	70
76	Receiver Electrical Parameters	70
77	AFE Interface Timing Specifications (see Figure 23)	70
78	Absolute Maximum Ratings.....	72
79	Recommended Operating Conditions	72
80	DC Electrical Characteristics.....	72
81	AFE Data Interface Timing Specifications (see Figure 24)	73
82	AFE Control Interface Timing Specifications (see Figure 5 and Figure 25)	74
83	TDM Interface Timing Specifications - T1 Transport Mode (see Figure 26)	74
84	Transceiver/Framer Reset Timing Specification	75
85	Intel Bus Parallel I/O Timing Characteristics (see Figure 27).....	75
86	Motorola Bus Parallel I/O Timing Characteristics (see Figure 27)	76



Revision History

Revision	Date	Description

Figure 1. SK70740/44 Block Diagram

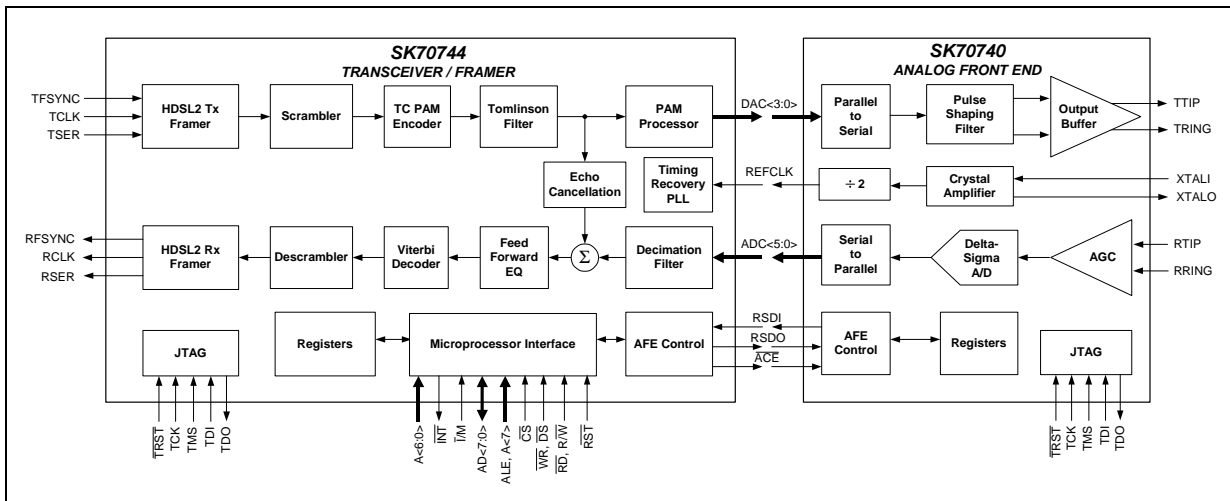

1.0 Pin Assignments and Signal Descriptions

Figure 2. Analog Front End Pin Assignments

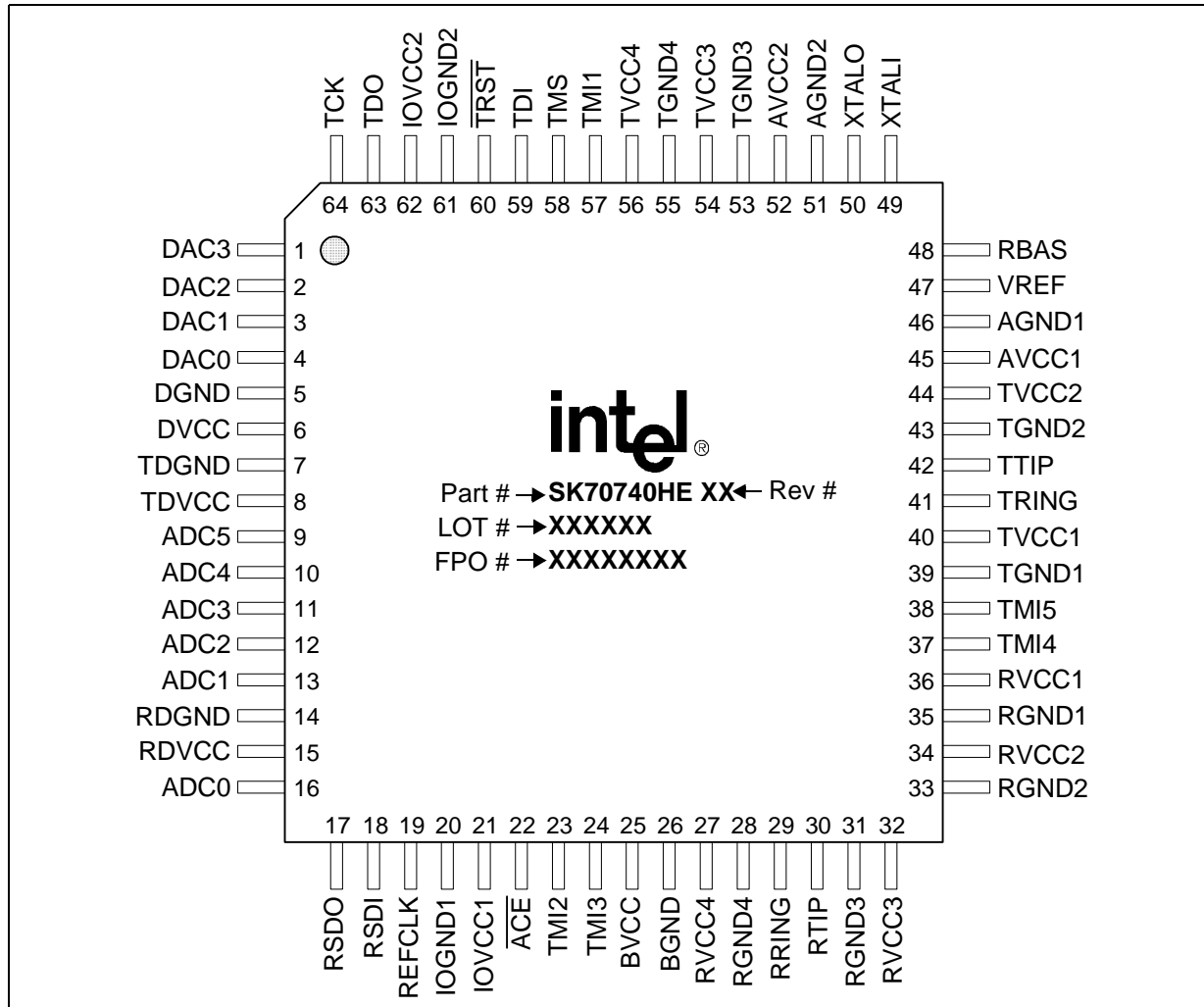

Package Topside Markings

Marking	Definition
Part #	Unique identifier for this product family.
Rev #	Identifies the particular silicon “stepping” — refer to the specification update for additional stepping information.
Lot #	Identifies the batch.
FPO #	Identifies the Finish Process Order.

Table 1. SK70740 Analog Front End Signal Descriptions

Group	Pin	Symbol	I/O ¹	Pin Description
Analog Core	48	RBAS	AO	Bias Resistor. External bias resistor connection point for current reference. A 24.9k Ω resistor and a 0.01 μ F capacitor should be connected between the RBAS pin and the AGND1 pin.
	47	VREF	AO	Voltage Reference Decoupling. External decoupling pin for internal voltage reference. A 0.47 μ F decoupling capacitor should be placed between the VREF pin and the AGND1 pin.
	49	XTALI	AI	Quartz Crystal or Clock Oscillator. Connect a 21.5 MHz crystal to XTALI and XTALO. Alternately, connect a 21.5 MHz clock oscillator to XTALI and ground the XTALO pin.
	50	XTALO	AO	
Line Interface	42	TTIP	AO	Transmit Tip and Ring. Transmit driver outputs. Connect to line driver circuit.
	41	TRING	AO	
	30	RTIP	AI	Receive Tip and Ring. Receiver differential inputs. Connect to line driver circuit.
	29	RRING	AI	
Transceiver Data Interface	1	DAC3	DI	Transmit Data Input. Four-bit parallel input from the Transceiver/Framer. Sampled on the rising edge of REFCLK. Connect to respective Transceiver/Framer pins DAC3 - DAC0.
	2	DAC2		
	3	DAC1		
	4	DAC0		
Transceiver Data Interface	9	ADC5	DO	Receive Data Output. Six bit parallel output from the AFE receive channel to the Transceiver/Framer. This pulse width modulated data is clocked on the rising edge of REFCLK. Connect to respective Transceiver/Framer pins ADC5 - ADC0.
	10	ADC4		
	11	ADC3		
	12	ADC2		
Transceiver Data Interface	13	ADC1	DO	Reference Clock. Clock signal derived from the local crystal. Provides timing reference to the Transceiver/Framer. The frequency of REFCLK is 1/2 the crystal frequency. Connect to Transceiver/Framer REFCLK pin.
	16	ADC0		
	19	REFCLK		
AFE Control Interface	17	RSDO	DI	Serial Control Input. Connect to RSDO pin of the Transceiver/Framer. Set-up and operating parameters are transferred to the AFE registers on this line. RSDO is sampled on the rising edge of REFCLK. Timing is shown in Figure 5 on page 21 .
	18	RSDI	DO	Serial Control Output. Connect to RSDI pin of the Transceiver/Framer. AFE register read data is transferred to the Transceiver/Framer on this line. RSDI is updated on the rising edge of REFCLK. Timing is shown in Figure 5 on page 21 .
	22	\overline{ACE}	DI	AFE Interface Chip Enable. Connect to \overline{ACE} pin of the Transceiver/Framer. When Low, enables register data transfer between the AFE and Transceiver/Framer. \overline{ACE} is sampled on the rising edge of REFCLK. Timing is shown in Figure 5 on page 21 .
1. DI = Digital Input; DO = Digital Output; DI/O = Digital Input/Output; AI = Analog Input; AO = Analog Output; AI/O = Analog Input/Output; S = Supply.				

Table 1. SK70740 Analog Front End Signal Descriptions (Continued)

Group	Pin	Symbol	I/O ¹	Pin Description
JTAG Interface	64	TCK	DI	Test Clock. Clock reference that synchronizes internal test operations. This pin has an internal pull-down.
	58	TMS	DI	Test Mode Select. Used to control the test logic state machine. Sampled on rising edge of TCK. TMS is pulled-up internally and may be left disconnected.
	63	TDO	DO	Test Data Output. Three state output used for reading all serial configurations and test data from internal test logic. Updated on falling edge of TCK.
	59	TDI	DI	Test Data Input. Used for loading serial instructions and data into internal test logic. Sampled on rising edge of TCK. TDI is pulled-up internally and may be left disconnected.
	60	$\overline{\text{TRST}}$	DI	Test Port Reset. This active Low signal resets the JTAG test port controller. If JTAG is not to be used, then connect this pin to GND externally. This pin has an internal pull-up.
Digital Power Supplies	6	DVCC	S	Digital Power Supply. Connect to +3.3 V ($\pm 5\%$).
	5	DGND	S	Digital Ground. Connect to 0 V. Return path for DVCC.
	21 62	IOVCC1 IOVCC2	S	I/O Positive Supply. Connect both pins to either +3.3 V or +5 V ($\pm 5\%$).
	20 61	IOGND1 IOGND2	S	I/O Ground. Connect to 0 V. Return path for IOVCC.
	8	TDVCC	S	Transmit Digital Positive Supply. Connect to +5 V ($\pm 5\%$). Powers the transmit clock generator.
	7	TDGND	S	Transmit Digital Ground. Connect to 0 V. Return path for TDVCC.
	15	RDVCC	S	Receive Digital Positive Supply. Connect to +5 V ($\pm 5\%$).
14	RDGND	S	Receive Digital Ground. Connect to 0 V. Return path for RDVCC.	
1. DI = Digital Input; DO = Digital Output; DI/O = Digital Input/Output; AI = Analog Input; AO = Analog Output; AI/O = Analog Input/Output; S = Supply.				

Table 1. SK70740 Analog Front End Signal Descriptions (Continued)

Group	Pin	Symbol	I/O ¹	Pin Description
Analog Power Supplies	36 34 32 27	RVCC1 RVCC2 RVCC3 RVCC4	S	Receive Power Supply. Connect to +5 V (\pm 5%).
	35 33 31 28	RGND1 RGND2 RGND3 RGND4	S	RVCC Ground. Connect to 0 V. Return path for RVCC.
	40 44 54 56	TVCC1 TVCC2 TVCC3 TVCC4	S	Transmit Power Supply. Connect to +5 V (\pm 5%).
	39 43 53 55	TGND1 TGND2 TGND3 TGND4	S	TVCC Ground. Connect to 0 V. Return path for TVCC.
	45 52	AVCC1 AVCC2	S	Analog Power Supply. Connect to +5 V (\pm 5%).
	46 51	AGND1 AGND2	S	AVCC Ground. Connect to 0 V. Return path for AVCC.
	25	BVCC	S	Bulk Power Supply. Connect to +5 V (\pm 5%). Powers all N-well guard rings to isolate major blocks of the chip.
	26	BGND	S	Bulk Ground. Connect to 0 V. Return path for BVCC.
Factory Test	57 23 24 37 38	TMI1 TMI2 TMI3 TMI4 TMI5	-	Factory Test Mode Interface. Leave <i>floating</i> for normal operation.
1. DI = Digital Input; DO = Digital Output; DI/O = Digital Input/Output; AI = Analog Input; AO = Analog Output; AI/O = Analog Input/Output; S = Supply.				

Figure 3. Transceiver/Framer Pin Assignments

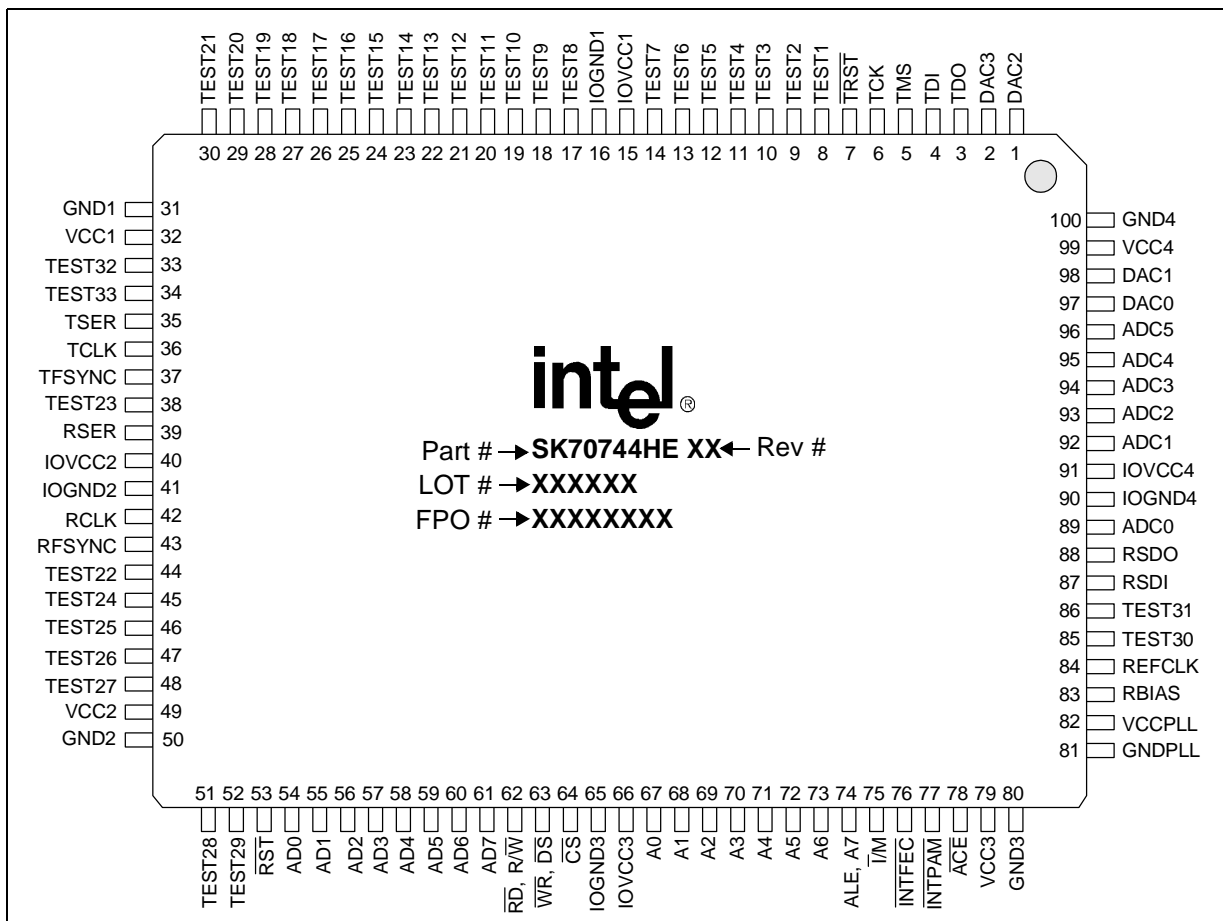

Package Topside Markings

Marking	Definition
Part #	Unique identifier for this product family.
Rev #	Identifies the particular silicon “stepping” — refer to the specification update for additional stepping information.
Lot #	Identifies the batch.
FPO #	Identifies the Finish Process Order.

Table 2. SK70744 Transceiver/Framer Signal Descriptions

Group	Pin	Symbol	I/O ¹	Description
Misc.	53	$\overline{\text{RST}}$	DI	Reset. Pulse Low to initialize internal circuits.
	83	RBIAS	AI	Bias. Sets internal bias of PLL. Connect to Ground through 15.8k Ω 1% resistor.
AFE Data Interface	2 1 98 97	DAC3 DAC2 DAC1 DAC0	DO	Transmit Data Output. Digital data output to AFE. Clocked out on rising edge of REFCLK. Connect to respective AFE pins DAC3 - DAC0.
	96 95 94 93 92 89	ADC5 ADC4 ADC3 ADC2 ADC1 ADC0	DI	Receive Data Input. Digital data input from AFE. Sampled on the rising edge of REFCLK. Connect to respective AFE pins ADC5 - ADC0.
Clock	84	REFCLK	DI	Reference Clock. Serial clock signal from AFE. Frequency is one half the AFE crystal reference for all rates. Synchronizes data transfers to/from the AFE. Connect to REFCLK pin of the AFE.
AFE Control Interface	88	RSDO	DO	Serial Control Output. Connect to RSDO pin of the AFE. Set-up and operating parameters are transferred to the AFE registers on this line. RSDO is sampled on the rising edge of REFCLK. Timing is shown in Figure 5 on page 21 .
	87	RSDI	DI	Serial Control Input. Connect to RSDI pin of the AFE. Read data from the AFE is transferred to the Transceiver/Framer on this line. RSDI is updated on the rising edge of REFCLK. Timing is shown in Figure 5 on page 21 .
	78	$\overline{\text{ACE}}$	DO	AFE Interface Chip Enable. Connect to $\overline{\text{ACE}}$ pin of the AFE. When held Low, enables register data transfer between the AFE and Transceiver/Framer. $\overline{\text{ACE}}$ is sampled on the rising edge of REFCLK. Timing is shown in Figure 5 on page 21 .
1. DI = Digital Input; DO = Digital Output; DI/O = Digital Input/Output; AI = Analog Input; AO = Analog Output; AI/O = Analog Input/Output; S = Supply.				

Table 2. SK70744 Transceiver/Framer Signal Descriptions (Continued)

Group	Pin	Symbol	I/O ¹	Description
μP Interface	61	AD7	DI/O	Address/Data Lines <7:0> . Multiplexed data/address bus in Intel mode. Data bus in Motorola mode.
	60	AD6		
	59	AD5		
	58	AD4		
	57	AD3		
	56	AD2		
	55	AD1		
	54	AD0		
	76	$\overline{\text{INTFEC}}$	DO	Interrupt Output from FEC/Framer . Open drain output. Requires an external 10 kΩ pull up resistor. Goes Low on interrupt.
	77	$\overline{\text{INTPAM}}$	DO	Interrupt Output from PAM Transceiver . Open drain output. Requires an external 10 kΩ pull up resistor. Goes Low on interrupt.
	64	$\overline{\text{CS}}$	DI	Chip Select . Pull Low to read or write Transceiver/Framer registers.
	62	$\overline{\text{RD}}, \overline{\text{R}\overline{\text{W}}}$	DI	Read Control . Low true read enable in Intel mode. $\overline{\text{R}\overline{\text{W}}}$ strobe in Motorola mode.
	63	$\overline{\text{WR}}, \overline{\text{DS}}$	DI	Write Control . Low true write enable in Intel mode. Low true data strobe in Motorola mode.
74	ALE, A7	DI	Address Latch Enable . In Intel mode, the falling edge latches the address present on multiplexed address/data bus. Address Line 7 in Motorola mode.	
73	A6	DI	Address Lines <6:0> In Motorola mode. <i>In Intel mode, A0 and A2 must be grounded to disable a factory test mode and allow normal operation.</i>	
72	A5	DI		
71	A4	DI		
70	A3	DI		
69	A2	DI		
68	A1	DI		
67	A0	DI		
75	$\overline{\text{I/M}}$	DI	Intel / Motorola Select . When Low, the microprocessor interface is configured for the Intel 80C51. When High, the microprocessor interface is configured for the Motorola 68000.	
TDM Interface	35	TSER	DI	Transmitter Serial Data . NRZ serial data into the HDSL2 frame mapper. Clocked on rising edge of TCLK.
	36	TCLK	DI	Transmit Data Clock . 1.544 MHz (± 130 ppm) serial clock signal from the T1 Framer.
	37	TFSYNC	DI	Transmit Frame Sync . Each Low-to-High transition indicates the start of a T1 frame.
	39	RSER	DO	Receive Serial Data . NRZ serial data from the HDSL2 frame mapper. Valid on falling edge of RCLK.
	42	RCLK	DO	Receive Data Clock . Serial clock signal from the HDSL2 frame mapper.
	43	RFSYNC	DO	Receive Frame Synchronization . 8 kHz frame sync signal from the DSL line. Asserted High for one RCLK cycle to indicate the start of a T1 frame.
1. DI = Digital Input; DO = Digital Output; DI/O = Digital Input/Output; AI = Analog Input; AO = Analog Output; AI/O = Analog Input/Output; S = Supply.				

Table 2. SK70744 Transceiver/Framer Signal Descriptions (Continued)

Group	Pin	Symbol	I/O ¹	Description
JTAG Interface	4	TDI	DI	Test Data Input. Used for loading serial instructions and data into internal test logic. Sampled on rising edge of TCLK. TDI is pulled up internally and may be left disconnected.
	5	TMS	DI	Test Mode Select. Used to control the test logic state machine. Sampled on rising edge of TCLK. TMS is pulled up internally and may be left disconnected.
	3	TDO	DO	Test Data Output. Three state output used for reading all serial configuration and test data from internal test logic. Updated on falling edge of TCLK.
	6	TCK	DI	Test Data Clock. TCK synchronizes internal test logic operations.
	7	$\overline{\text{TRST}}$	DI	Test Port Reset. This active Low signal resets the JTAG test port controller. If JTAG is not to be used, then connect this pin to GND externally. This pin has an internal pull-up.
Factory Test	8 9 10 21 22 23 24 25 26 45 46 51	TEST1 TEST2 TEST3 TEST12 TEST13 TEST14 TEST15 TEST16 TEST17 TEST24 TEST25 TEST28	DI	Input Test Pins. Used for factory test purposes. <i>Connect to ground</i> for normal operation.
	11 12 13 14 17 18 19 20 44 38 47 48 86 33 34	TEST4 TEST5 TEST6 TEST7 TEST8 TEST9 TEST10 TEST11 TEST22 TEST23 TEST26 TEST27 TEST31 TEST32 TEST33	DO	Output Test Pins. Used for factory test purposes. <i>Let float.</i> Do not connect to VCC or ground.
	85	TEST30	DI/O	Input/Output Test Pin. Used for factory test purposes. <i>Let float.</i> Do not connect to VCC or ground.
No Connect	27 28 29 30 52	TEST18 TEST19 TEST20 TEST21 TEST29	-	Not Connected
1. DI = Digital Input; DO = Digital Output; DI/O = Digital Input/Output; AI = Analog Input; AO = Analog Output; AI/O = Analog Input/Output; S = Supply.				

Table 2. SK70744 Transceiver/Framer Signal Descriptions (Continued)

Group	Pin	Symbol	I/O ¹	Description
Power	32 49 79 99	VCC1 VCC2 VCC3 VCC4	S	Logic Supply. Connect to +2.5 V ($\pm 5\%$).
	31 50 80 100	GND1 GND2 GND3 GND4	S	Logic Ground. Connect to 0V. Return path for VCC.
	15 40 66 91	IOVCC1 IOVCC2 IOVCC3 IOVCC4	S	I/O Pad Ring Supply. Connect to 3.3 V ($\pm 5\%$)
	16 41 65 90	IOGND1 IOGND2 IOGND3 IOGND4	S	I/O Pad Ring Ground. Connect to 0 V. Return path for IOVCC.
	82	VCCPLL	S	Phase Lock Loop Supply. Connect to +2.5 V ($\pm 5\%$)
	81	GNDPLL	S	Phase Lock Loop Ground. Connect to 0 V. Return path for VCCPLL.
1. DI = Digital Input; DO = Digital Output; DI/O = Digital Input/Output; AI = Analog Input; AO = Analog Output; AI/O = Analog Input/Output; S = Supply.				

2.0 General Functional Description

2.1 Overview

The SK70740/44 chip set provides frame mapping, transceiver, and line interface functions for single pair HDSL2. The SK70740/44 chip set is a highly flexible modem that can be configured through programmable registers for multiple applications. An internal activation controller minimizes the load on the system processor and reduces the software development required to operate the modem. Upon receiving an activation request from the system processor, the device will automatically initialize and configure the transceiver. Once activated, the only intervention required by the system processor is a periodic read and service of the modem's interrupt status registers.

The I/O operates at 3.3 V logic levels which are 5.0 V tolerant. The digital core logic operates at 2.5 V for reduced power consumption.

Different naming conventions are commonly used to refer to the modems at the central office and subscriber. The modem at the central office is often referred to as the Line Termination Unit (LTU) or HDSL2 Terminal Unit (H2TU-C). The remote end is often referred to as the Network Termination Unit (NTU) or H2TU-R. In this document, the names H2TU-R and H2TU-C will be used. By convention, the H2TU-C transmits in the downstream direction and the H2TU-R transmits upstream. The modem may be configured for either application through the Main 0 Control register.

Figure 4. HDSL2 Modem

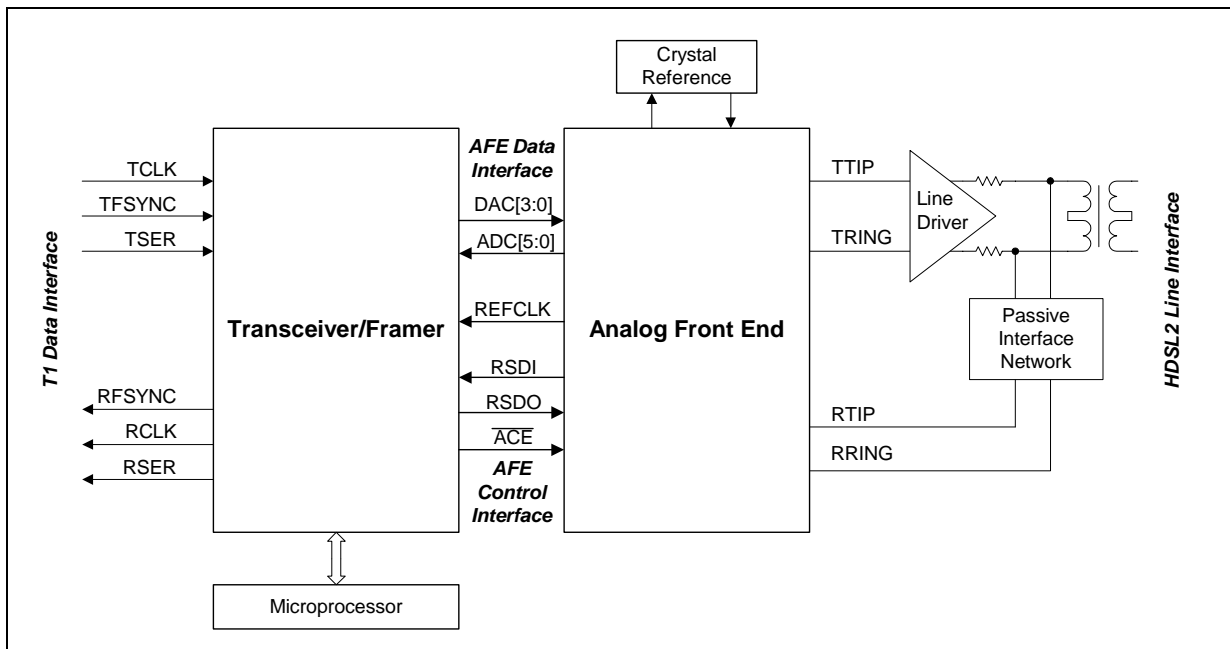

2.2 Transceiver-AFE Interfaces

2.2.1 Data Interface

The PAM Transceiver and the AFE work together to provide the Digital-to-Analog (D/A) conversion. A Delta-Sigma modulator in the Transceiver/Framer over-samples the transmit data and produces a pulse width modulated data stream that is sent to the AFE on DAC[3:0]. Transfers are synchronized with the rising edge of REFCLK. Subsequent filtering in the AFE removes quantization noise, resulting in a highly linear D/A function.

Likewise, in the receive channel, a Delta-Sigma modulator in the AFE oversamples the incoming data stream. The resulting pulse width modulated data stream is sent to the Transceiver/Framer on ADC[5:0]. A decimation filter in the Transceiver/Framer removes out-of-band energy and recovers the signal from the pulse width modulated input. After the decimation filter, an Echo Canceller subtracts the transmitted signal and line echo from the received data.

2.2.2 Control Interface

The AFE is controlled by the Transceiver/Framer via a 3-wire serial microcontroller interface. This serial interface transports AFE configuration parameters and control functions which are specified by the AFE registers. Note that the AFE registers are accessed through Transceiver/Framer registers: AFE_CTL, AFE_ADD, and AFE_STAT as described in “[AFE Registers](#)” on page 47.

AFE interface timing and data structure is shown in [Figure 5](#). The interface becomes active when the chip select (\overline{ACE}) line is asserted Low by the Transceiver/Framer. Transceiver/Framer register AFE_ADD specifies both the operation (read or write) and the particular register to be accessed. The RSDO line carries the r/w bit. The data moves across the interface in 16-bit blocks and is synchronized with the rising edge of the REFCLK line. The RSDO line is used to write data to the AFE while the RSDI line receives data. Data is written MSB first, with a 7-bit address followed by an 8-bit data word.

2.3 JTAG Interface

A separate JTAG test port is included in both the AFE and the Transceiver/Framer chips to enable boundary scan testing at the system manufacturing level. The JTAG port is fully compliant with the IEEE standard 1149.1-1990, “Standard Test Access Port and Boundary Scan Architecture” set by the Joint Test Actions Group (JTAG). Board connectivity can be verified at all digital pins through a set of three instructions accessible through the use of a state machine standard to all JTAG controllers. Refer to IEEE 1149.1 specification for details concerning the JTAG instruction register and JTAG state machine.

Figure 5. Transceiver/AFE Control Interface Data Structure

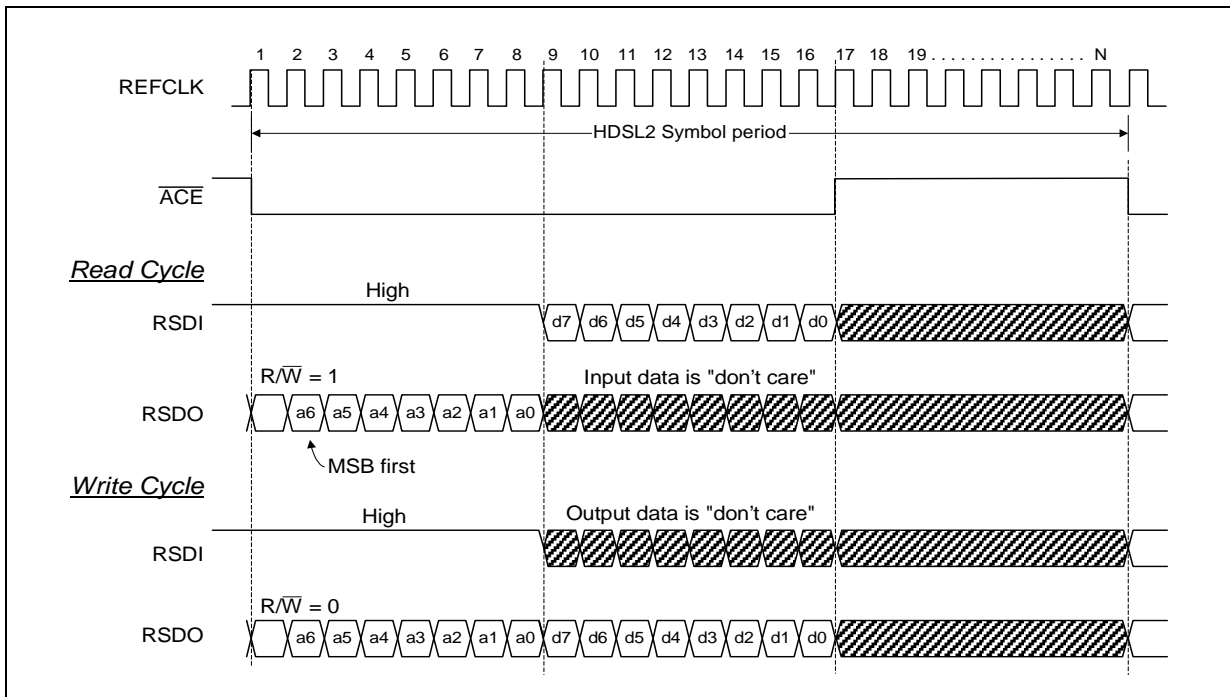

3.0 AFE Functional Description

The SK70740 Analog Front End (hereafter referred to as the AFE) provides the line interface for the HDSL2 modem.

HDSL2 uses overlapping power spectrums for upstream and downstream transmission on a single twisted pair. Transmission in both directions is simultaneous, requiring echo cancellation to separate the two data streams. First-order echo cancellation is provided at the RTIP/RRING input, while the DSP in the Transceiver removes the remainder of the echo. The following analog functions are integrated into the AFE:

- Echo cancellation
- Transmit D/A termination and filters
- Transmit pre-driver
- Receiver AGC
- Receiver A/D converter
- Crystal oscillator amplifier
- Current and voltage references

The AFE operates as a slave to the Transceiver. All programming is done through the Transceiver. Configuration, status, and control signals are passed between the two devices across a serial control bus. The AFE provides the timing reference and operates from a simple crystal. The switched capacitor filters and receive Delta-Sigma modulator in the AFE operate at the reference crystal frequency. Clock recovery and baud clock synchronization occur in the Transceiver.

3.1 Upstream and Downstream Spectrums

The switched capacitor filters in the transmit channel set the bandwidth for the outgoing signal spectrum. Two filter settings are available, corresponding to the T1 upstream and downstream spectrums. The AFE_CTL register in the Transceiver configures the AFE for upstream and downstream transmission. Configuration control words are then sent to the AFE via the AFE Control Interface. For central office applications (H2TU-C), the device is set for downstream spectrum while remote (H2TU-R) applications utilize the upstream spectrum.

Precise control of the upstream and downstream Power Spectral Density (PSD) enables HDSL2 to coexist with other transmission technologies such as: T1, ADSL, and conventional HDSL. Most of the PSD shaping occurs in the Transceiver, while the transmit filter in the AFE limits out-of-band noise. The AFE transmitter frequency response is shown in [Figure 6](#).

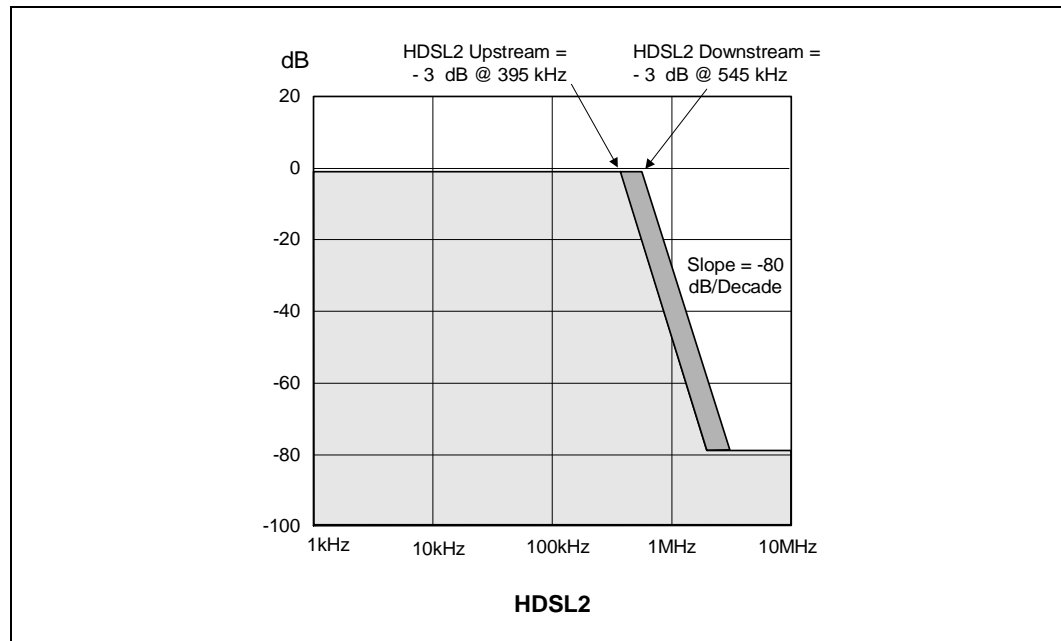
Figure 6. Transmit Frequency Response

3.2 Transmitter

The AFE outputs a PAM-16 signal. Within the Transceiver, a Delta-Sigma modulator produces an over-sampled Pulse Width Modulated (PWM) data stream. The data comes across a 4 bit interface port (DAC<3:0>) and is terminated by an analog DAC in the AFE. The AFE shapes the transmitted spectrum by filtering this PWM data.

The AFE transmit pre-driver delivers a 2.6 V_{p-p} differential signal to the external line driver. This pre-driver can drive a load as low as 500 Ω single-ended or 1 kΩ differential.

3.3 Receiver

The AFE receiver is a Delta-Sigma A/D converter. While the first stage echo cancellation removes much of the transmitted signal from the received signal, the received signal may still be much smaller than the transmitted signal. Since both signals must be processed simultaneously, the A/D converter requires high dynamic range to provide adequate resolution for the received signal. The Delta-Sigma modulator over-samples the data to provide the high dynamic range required to recover the PAM constellation.

The input gain of the receiver is controlled through AFE register AR2. Eight settings allow a receiver gain range of: +3 dB to -18 db (in 3 dB steps). The AFE and Transceiver work together to provide a gain control loop.

Data from the AFE undergoes a serial-to-parallel conversion and is passed across a 6-bit interface (ADC<5:0>). The signal is then decimated in the PAM Transceiver.

3.4 Line Interface

Since the upstream and downstream spectrums overlap, the input to the receiver consists of both spectrums. A hybrid network at the receiver input provides first order echo cancellation, thereby reducing the dynamic range of the A to D converter. The hybrid network is designed to deliver the received signal, scaled to 1/2 amplitude, to the receiver input. The passive cancellation network also removes over 6 dB of transmitted signal echo from the receive input. Subsequent echo cancellation in the digital transceiver is used to fully separate the upstream and downstream signals.

A block diagram of line interface network is shown in Figure 7. HDSL2 uses a single transformer interface to the twisted pair line. The transmit and receive lines branch out to the AFE. An external line driver and a step-up transformer with a turns ratio of 1:2.3, delivers over 16 dBm power to the line. At the TTIP/TRING outputs, two termination resistors are used in series with the transformer to properly match the 135 Ω twisted pair line. A first order passive filter is used between the AFE and the external line driver to minimize out-of-band noise in the transmit spectrum. The cut-off frequency of the filter is nominally set to 590 KHz.

A first-order passive filter is also used at the RTIP/RRING inputs. The cut-off frequency of this filter is nominally set at 1.0 MHz.

Refer to Application Note *HDSL2 System Design and Chip Set Overview* for recommended line interface network circuit details. Also, protection circuitry should be inserted at the line side of the transformer. Refer to Intel Application Note *MDSL/HDSL Line Protection Circuit* for details.

Figure 7. Line Interface Network

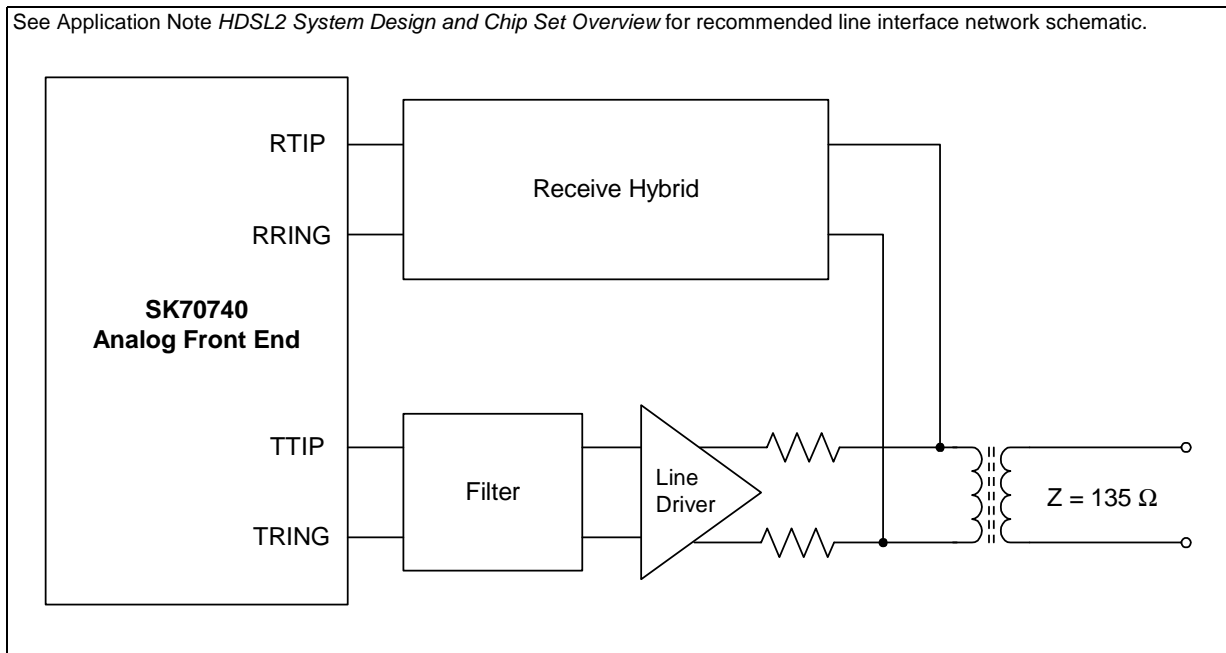

3.5 Reference Clock

The switched capacitor filters and Delta-Sigma modulator in the AFE operate at a fixed frequency. System timing recovery is done digitally in the Transceiver. For typical H2TU-C and H2TU-R applications, the AFE operates with a 21.500 MHz crystal. The AFE divides the local clock by 2 and passes it to the Transceiver across the REFCLK line. If desired, the AFE can be driven by an external clock of the same accuracy. To do this, connect the XTALO pin to ground and connect the external clock to the XTALI pin.

3.6 Loopbacks

As shown in Figure 8, two loopback functions are provided for diagnostics and debugging purposes. Within the AFE, the transmitter outputs (TTIP/TRING) are connected into the receiver inputs (RTIP/RRING). With this configuration (Analog External Loopback) the signal will be present on the line. The Analog Internal Loopback configuration connects the output of the switched capacitor filter to the input of the AGC stage. The transmit buffer is bypassed and the signal is isolated from the line. Loopback operation is configured in the AFE_CTL register.

Figure 8. Loopback Data Paths

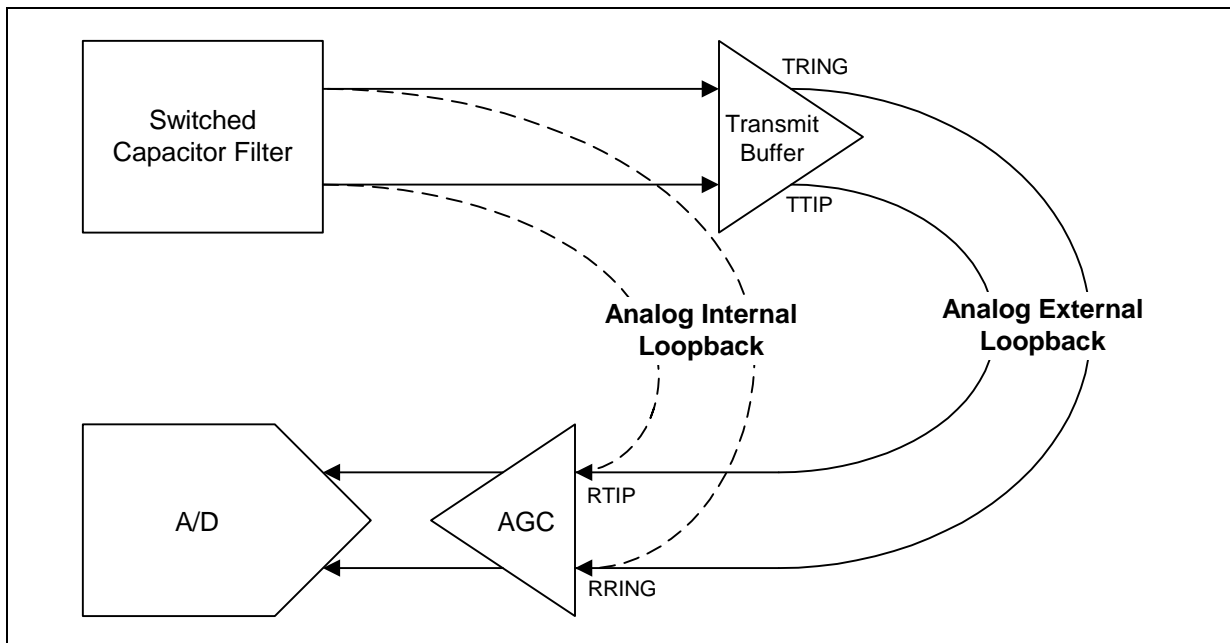

4.0 Transceiver/Framer Functional Description

4.1 TDM Interface

4.1.1 T1 Transport Operation

The SK70744 (hereafter referred to as the Transceiver/Framer) is designed to interface with standard T1 framers. The device maps 1.544 Mbps DS1 payloads into a 1.552 Mbps HDSL2 frame. For standard operation, the DS1 payload and HDSL2 frames are not aligned with respect to one another. In this application, the data interface simply uses TSER, RSER, TCLK, and RCLK, while the TFSYNC and RFSYNC lines are not used.

Should the application require frame alignment, the TFSYNC input may be used to indicate the T1 frame alignment. See [Figure 9 on page 28](#). This allows the HDSL2 frame to be aligned with the incoming T1 frame under software control. Likewise, the RFSYNC output sends a reference T1 frame pulse at the beginning of each HDSL2 frame. The transmit and receive FIFOs guarantee that the DS1 bit 0 coincides with TFSYNC in the transmit channel and RFSYNC in the receive channel. Alignment is controlled by setting the FIFO water levels in registers HTFWL[7:0] and HFRWL[7:0]. The water levels establish the throughput delay of the transmit and receive FIFOs and the differential delay that the frame mapper must wait prior to loading or extracting data from receive and transmit FIFOs. The water levels are set by first characterizing the delay between the DS1 and HDSL2 frames in the transmit and receive channel. A corresponding offset delay is then inserted into the transmit and receive FIFOs. The actual delay offset varies over time due to stuff bit insertion, clock jitter and wander between the DS1 and HDSL2 frames. Internal low wander circuits and jitter attenuation correct these secondary effects and synchronize the two frames.

The TSER and RSER lines are used to transfer serial data from a T1 framer. For each HDSL2 symbol, three bits are sent in and out of TSER and RSER. Data is sampled on TSER at each falling edge of TCLK, while data is clocked out of RSER on each rising edge of RCLK.

4.2 T1 Frame Mapping

The Transceiver/Framer maps T1 frames into the HDSL2 frame format. A block diagram of the transmit framer is shown in [Figure 10 on page 28](#).

[Figure 11 on page 29](#) shows the HDSL2 frame format. The duration of the frame is nominally 6 ms, regardless of the line rate. The frame consists of 48 overhead bits and 4 payload blocks.

With the exception of sync word and stuff bits, all transmit data is scrambled prior to moving to the FEC stage. Configuration of the scramblers is accomplished through the HTFTMR register. The upstream and downstream polynomials are as follows:

- H2TU-C Scrambler = $x^{-23} + x^{-5} + 1$
- H2TU-C Descrambler = $x^{-23} + x^{-18} + 1$
- H2TU-R Scrambler = $x^{-23} + x^{-18} + 1$
- H2TU-R Descrambler = $x^{-23} + x^{-5} + 1$

4.2.1 Transmit Frame Mapping

The frame mapper receives data from the TDM bus and multiplexes a SYNC word, Cyclic Redundancy Check (CRC) bits, HDSL2 Over Head (HOH) and stuff bits into the HDSL2 frame. The data is scrambled prior to being sent to the FEC encoder. The 6 msec HTSYNC pulse defines the HDSL2 frame boundaries. The framer automatically manages the sync, CRC, and bit stuffing functions. 24 EOC bits are accessible through the device registers.

The CRC is calculated for every frame, excluding the 10 bit SYNC word, 6 CRC bits, and any stuff bits. Each calculated CRC is inserted into the subsequent frame. The CRC Polynomial is X^6+X+1 . Check bits crc1-crc6, contained in the frame, are associated with the contents of the preceding frame.

When there is no preceding frame, the CRC number will be set to a default of zero. At the receive end, the CRC polynomial is multiplied by X^6 and divided by X^6+X+1 to determine if an error has occurred. Errors are reported in the HRFSR register.

The average HDSL2 frame transports 48 overhead bits. The name and function of these overhead bits is defined by ANSI T1E1.418 and are described in [Table 4 on page 30](#).

Since the upstream and downstream T1 payload rates are not synchronous with the HDSL2 symbol rate, bit stuffing is used to handle the rate adaptation between the symbol rate and the payload rate. FIFO buffers in the transmit and receive data path are used to monitor and buffer the variations in transmission rate. The insertion of stuffing bits is done automatically based on the transmit FIFO water level. By adjusting the ratio of frames with stuffing, to those without stuffing, data is carried across the HDSL2 symbol stream at the payload data rate. Stuff indicator bits are added to the HDSL2 frame to improve the system's ability to recover from impulse noise during a frame sync error.

With bit stuffing, the data stream may experience a low frequency timing wander. Wander reduction may be implemented by modulating the FIFO water levels.

HDSL2 uses High-speed Data Link Control (HDLC) framing to transfer EOC messages between each end of the link. Each EOC frame may consist of one or more messages. Start and stop flags delineate the frame, while a 16 bit CRC is used for the Frame Check Sequence (FCS). Each EOC message is an integer number of octets and contains the following common fields:

- Message Type
- Length
- Source ID
- Information

The following message types are defined by ANSI:

- Performance Status
- Read Request
- Read Acknowledgment
- Configuration Request
- Register Status
- Priority Message

The Transceiver/Framer supports ANSI EOC messaging by providing access to the EOC bits through the HTFOH1-HTFOH4 and the HRFOH1-HRFOH4 registers. Management of these bits and the HDLC controller function is left to the system microprocessor.

Figure 9. Relative Timing for TDM Interface in T1 Transport Mode

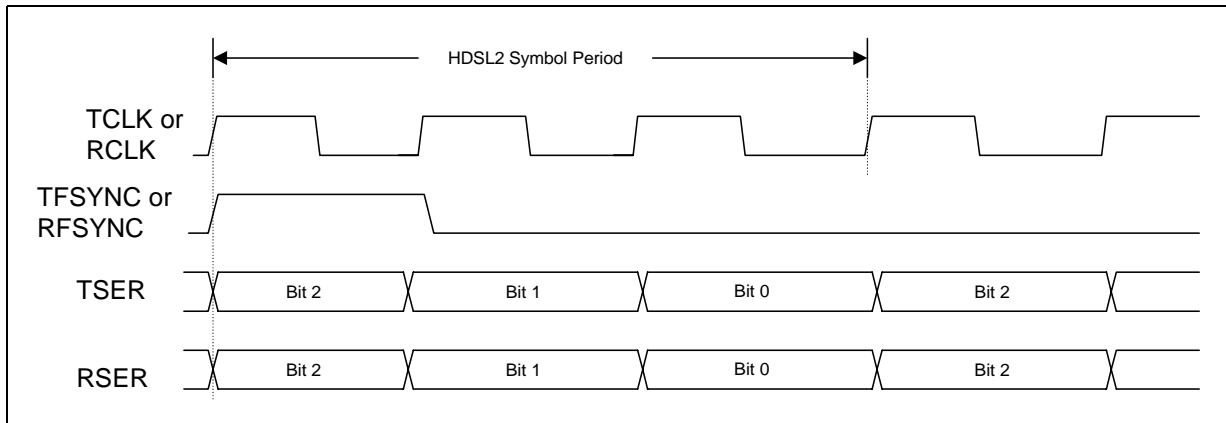

Figure 10. Transmit Framer Block Diagram

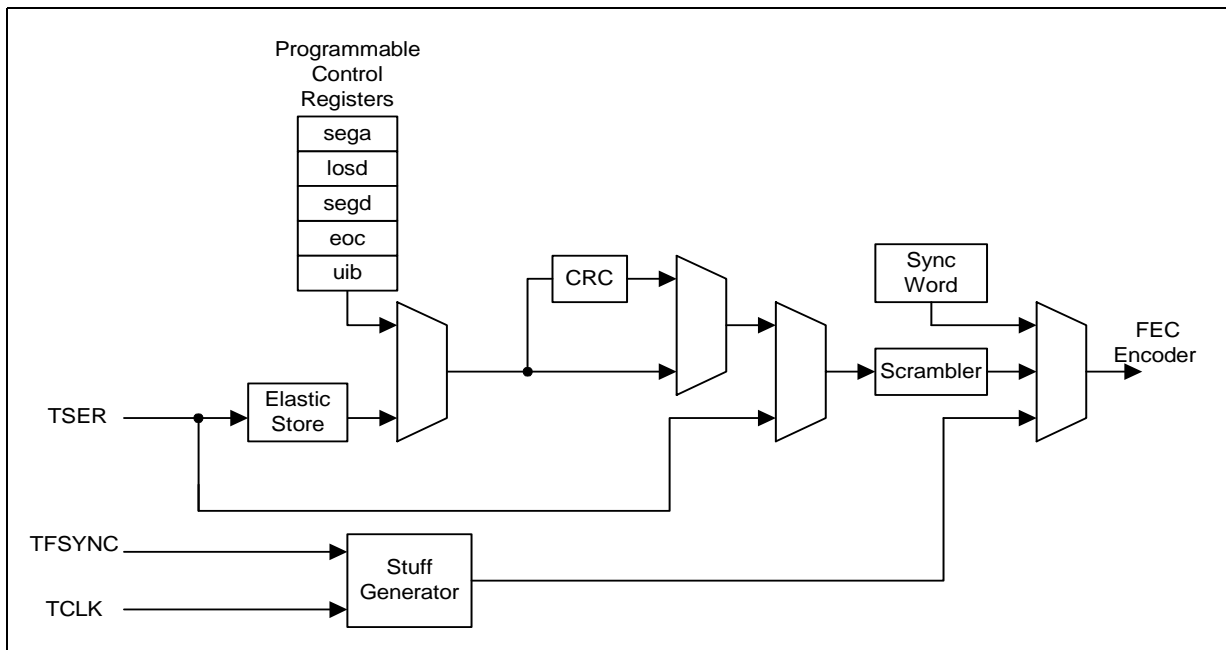
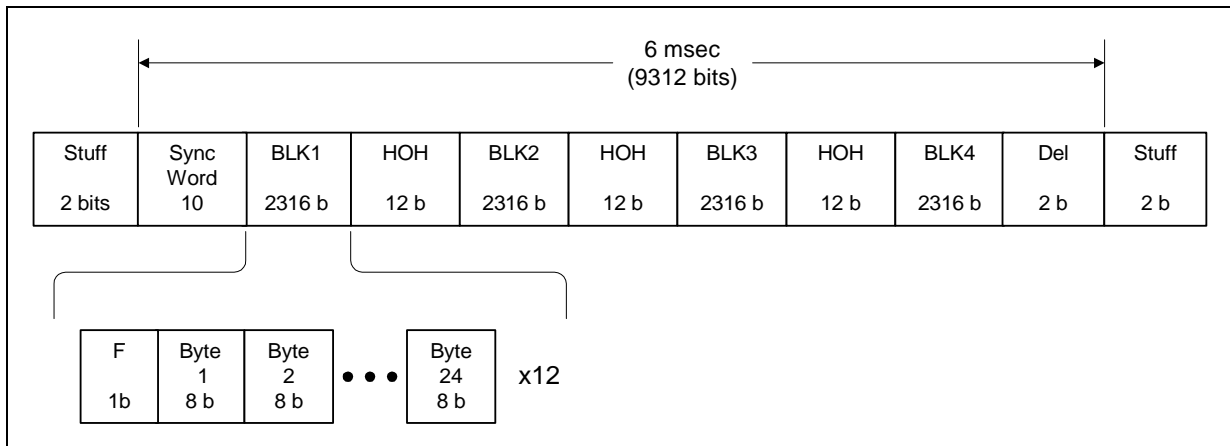

Figure 11. HDSL2 Frame Format for T1 Payload

Table 3. HDSL2 Frame Structure for T1

Frame Bit #	HOH Bit #	Name	Description
1-10	1-10	sw1-10	Sync word, 10 bits
11-2326	-	B1	Payload Block 1
2327	11	crc1	CRC-6 bit 1 for previous frame
2328	12	crc2	CRC-6 bit 2 for previous frame
2329	13	sbid1	Stuff Bit Identification 1
2330	14	losd	DS1 loss of signal detect
2331-2338	15-22	eoc01-eoc08	EOC bit 1 - EOC bit 8
2339-4654	-	B2	Payload Block 2
4655	23	crc3	CRC-6 bit 3 for previous frame
4656	24	crc4	CRC-6 bit 4 for previous frame
4657	25	uib	Unspecified indicator bit
4658	26	sega	Segment Anomaly
4659-4666	27-34	eoc9-eoc16	EOC bit 10 through EOC bit 16
4667-6982	-	B3	Payload Block 3
6983	35	crc5	CRC-6 bit 5 for previous frame
6984	36	crc6	CRC-6 bit 6 for previous frame
6985	37	sbid2	Stuff Bit Identification 2
6986	38	segd	Segment defect
6987-6994	39-46	eoc17-eoc24	EOC bit 17 through EOC bit 24
6995-9310	-	B4	Payload Block 4
9311	47	sb1	stuff bit 1
9312	48	sb2	stuff bit 2
9313	49	sb3	stuff bit 3
9314	50	sb4	stuff bit 4

Table 4. HDSL2 Overhead Bit to Register Mapping

HOH bit#	Name	Write Register	Bit #	Read Register	Bit #
1	fsw1	HTFFSW1	7	Not available	-
2	fsw2	HTFFSW1	6	Not available	-
3	fsw3	HTFFSW1	5	Not available	-
4	fsw4	HTFFSW1	4	Not available	-
5	fsw5	HTFFSW1	3	Not available	-
6	fsw6	HTFFSW1	2	Not available	-
7	fsw7	HTFFSW1	1	Not available	-
8	fsw8	HTFFSW1	0	Not available	-
9	fsw9	HTFFSW2	1	Not available	-
10	fsw10	HTFFSW2	0	Not available	-
11	crc1	Internally generated	-	Not available	-
12	crc2	Internally generated	-	Not available	-
13	sbid1	Internally generated	-	HRFFDR	7
14	losd	HTFHOH3	5	HRFHOH3	5
15	eoc1	HTFHOH3	6	HRFHOH3	6
16	eoc2	HTFHOH1	0	HRFHOH1	0
17	eoc3	HTFHOH1	1	HRFHOH1	1
18	eoc4	HTFHOH1	2	HRFHOH1	2
19	eoc5	HTFHOH1	3	HRFHOH1	3
20	eoc6	HTFHOH1	4	HRFHOH1	4
21	eoc7	HTFHOH1	5	HRFHOH1	5
22	eoc8	HTFHOH1	6	HRFHOH1	6
23	crc3	Internally generated	-	Not available	-
24	crc4	Internally generated	-	Not available	-
25	uib	HTFHOH3	7	HRFHOH3	7
26	sega	HTFHOH4	4	HRFHOH4	4
27	eoc9	HTFHOH4	5	HRFHOH4	5
28	eoc10	HTFHOH1	7	HRFHOH1	7
29	eoc11	HTFHOH2	0	HRFHOH2	0
30	eoc12	HTFHOH2	1	HRFHOH2	1
31	eoc13	HTFHOH2	2	HRFHOH2	2
32	eoc14	HTFHOH2	3	HRFHOH2	3
33	eoc15	HTFHOH2	4	HRFHOH2	4
34	eoc16	HTFHOH2	5	HRFHOH2	5
35	crc5	Internally generated	-	Not available	-
36	crc6	Internally generated	-	Not available	-
37	sbid2	Internally generated	-	HRFFDR	6

Table 4. HDSL2 Overhead Bit to Register Mapping (Continued)

HOH bit#	Name	Write Register	Bit #	Read Register	Bit #
38	segd	HTFHOH4	6	HRFHOH4	6
39	eoc17	HTFHOH4	7	HRFHOH4	7
40	eoc18	HTFHOH2	6	HRFHOH2	6
41	eoc19	HTFHOH2	7	HRFHOH2	7
42	eoc20	HTFHOH3	0	HRFHOH3	0
43	eoc21	HTFHOH3	1	HRFHOH3	1
44	eoc22	HTFHOH3	2	HRFHOH3	2
45	eoc23	HTFHOH3	3	HRFHOH3	3
46	eoc24	HTFHOH3	4	HRFHOH3	4
47	sb1	HTFHOH4	3	HRFHOH4	3
48	sb2	HTFHOH4	2	HRFHOH4	2
49	sb3	HTFHOH4	1	HRFHOH4	1
50	sb4	HTFHOH4	0	HRFHOH4	0

4.2.2 Receive Frame Mapping

The receive framer aligns the frame, removes stuffing bits, extracts the overhead bits, and monitors error performance. Data from the FEC decoder, is first descrambled. Once a sync word is detected, the framer is able to count bits and locate the other overhead data. The crc1-crc6 bits are checked and the errors are monitored with a counter.

CRC errors are reported to the HRFCRC register.

Figure 12. Receive Framer Block Diagram

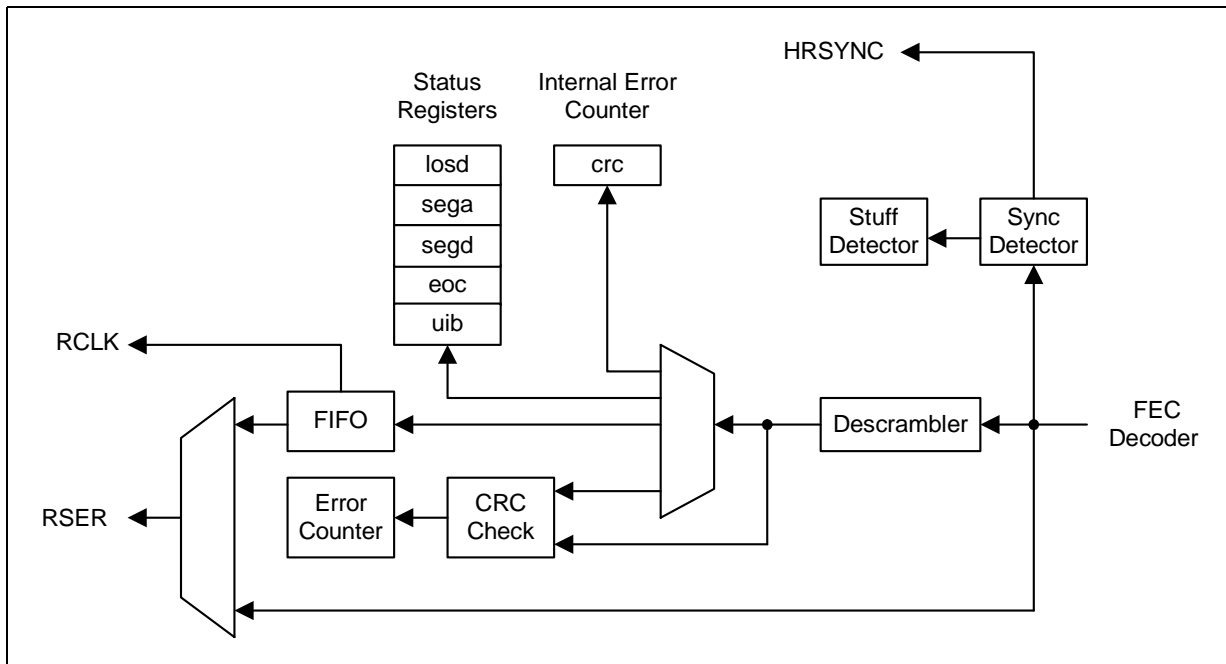

4.3 Frame Synchronization

See Figure 13. Frame synchronization may be monitored in the Receive Status register (HRFSR) with the fsevent, fcsync, and fsdet bits. Once the frame mapper receives two frames with valid framing bits, fcsync is set to '1' and the 6 ms receive frame interrupt is enabled. The system processor must read the HRFSR every 6 ms to monitor frame sync status and CRC errors. The fsevent bit is set to '1' during the 6 ms interrupt to indicate the start of each HDSL2 receive frame. The HRFSR should be read during the interrupt. If no framing bit errors were detected, the fsdet bit is set to '1'. If a frame with framing bit errors was received, the fsdet bit is set to '0'. The system processor may handle loss of frame sync detection using the fsdet bit. Alternatively, the Transceiver/Framer will automatically declare loss of frame sync when the HRFCR register bit "up_syncdis" is set to '1'.

Figure 13. Frame Synchronization Operation

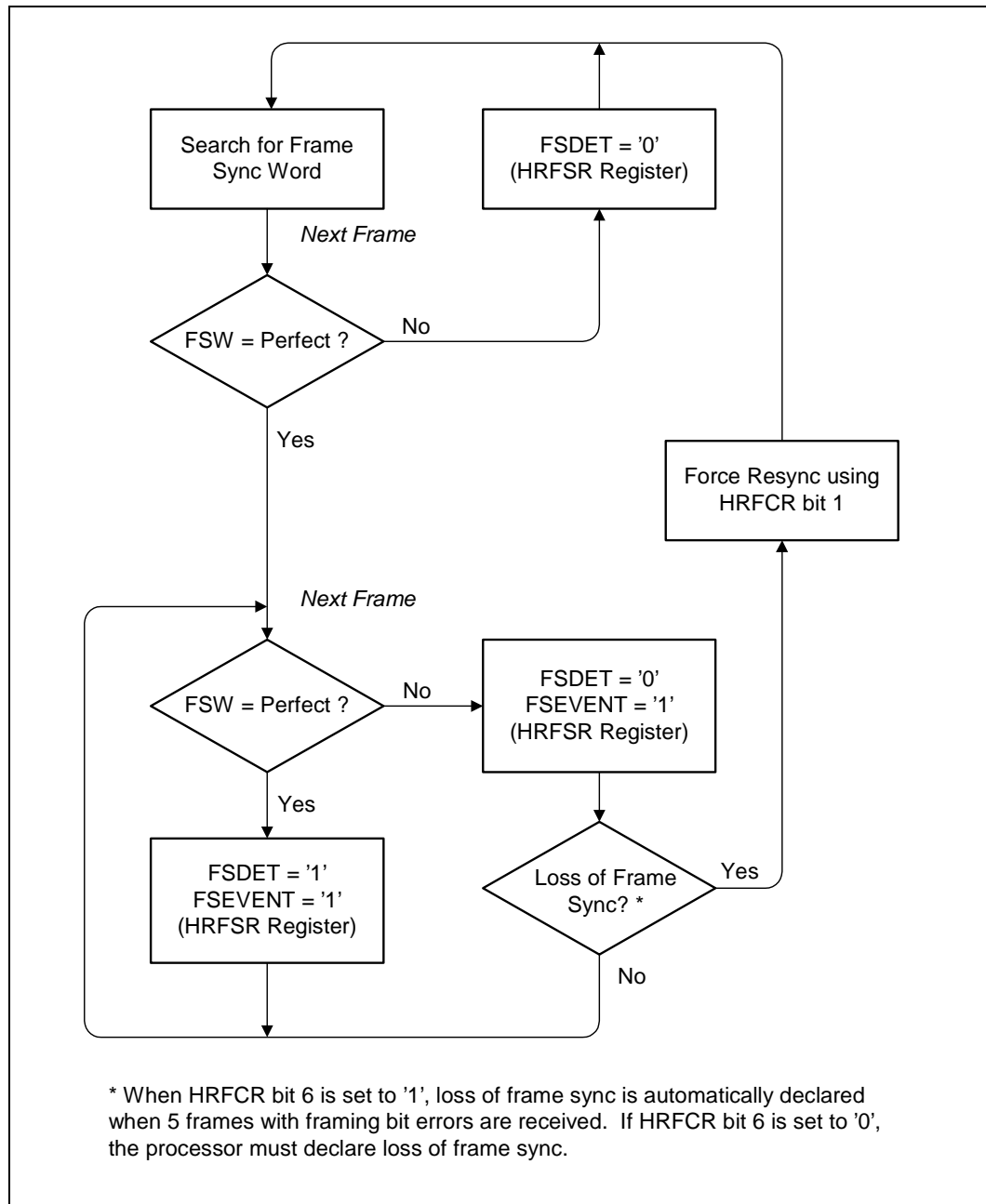

4.4 Forward Error Correction (FEC)

4.4.1 FEC Encoder

The Transceiver/Framer utilizes Trellis Code Modulation (TCM) to provide over 5 dB of coding gain to the HDSL2 transmission system. In the transmit direction, the HDSL2 frame mapper feeds the FEC a 3 bit data vector, X[2:0]. As shown in Figure 14, bit X0 is encoded and sent to a 1/2 rate convolution coder with a constraint length of 20. The output of the encoder is sent to the one dimensional symbol mapper, along with bits X[2:1]. The output symbol, S, is subsequently transmitted on the transmission line.

Figure 15 shows a block diagram of the feed-forward convolutional encoder. T_S is a delay of one symbol time, “ \oplus ” is a binary exclusive-OR and “ \bullet ” is a binary AND. The encoder is essentially a shift register, whereby each tap is multiplied by a binary coefficient. The numerical representation of the coefficients is A and B where:

$$A = a_{20} \bullet 2^{20} \oplus a_{19} \bullet 2^{19} \oplus a_{18} \bullet 2^{18} \dots \oplus a_0 \bullet 2^0$$

$$B = b_{20} \bullet 2^{20} \oplus b_{19} \bullet 2^{19} \oplus b_{18} \bullet 2^{18} \dots \oplus b_0 \bullet 2^0$$

The coefficient values may be programmed through the CG0 and CG1 registers. During activation, the A and B coefficients may be passed from the H2TU-C to H2TU-R to configure the system for alternate line codes.

Figure 14. FEC Encoder and Symbol Mapping

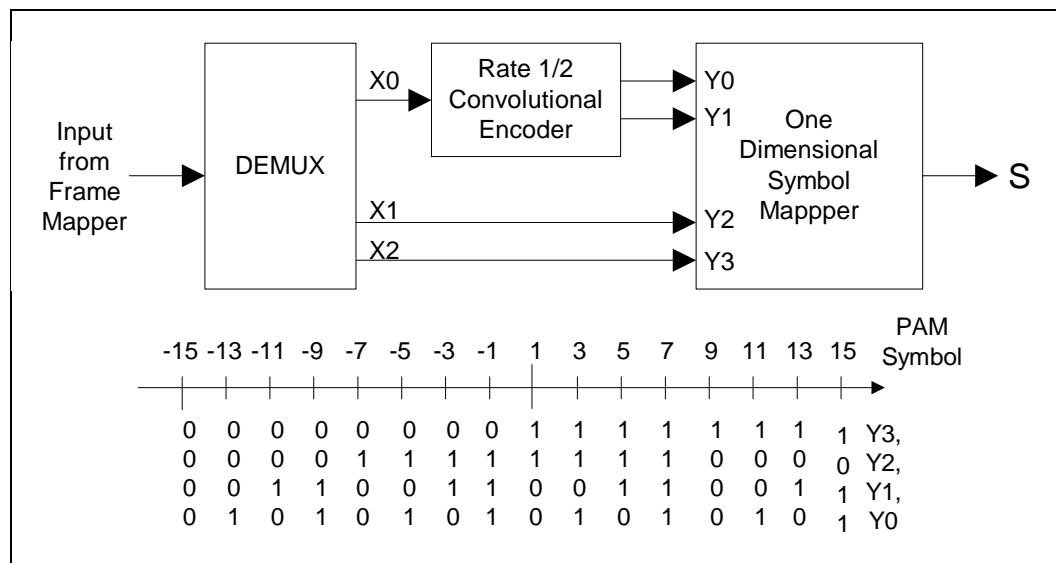
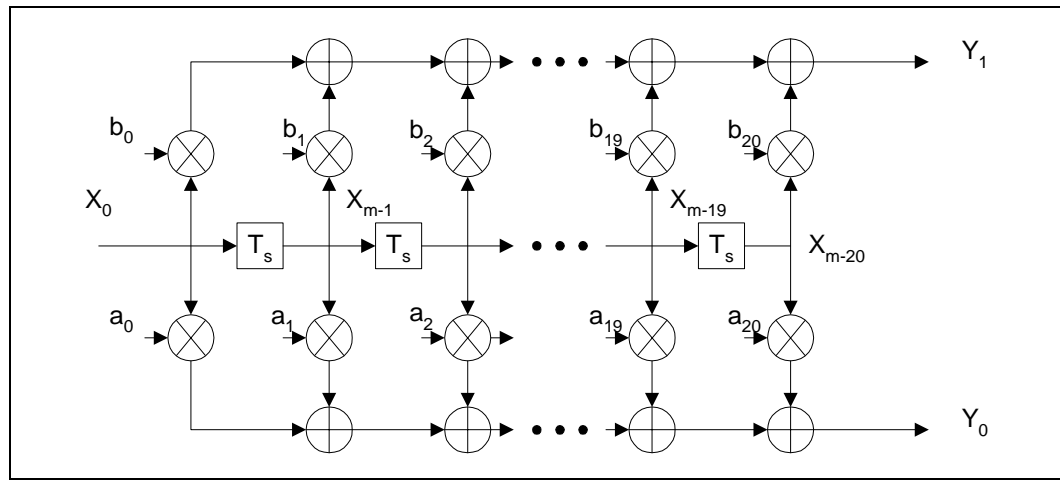

Figure 15. Convolutional Encoder



4.4.2 FEC Decoder

In the receive direction, the FEC decoder receives 10 bit soft decision words (R) from the slicer. As shown in Figure 16, the outputs from the decoder are 3 bit vectors, X[2:0], that are passed to the subsequent framer.

A soft decision metric is first calculated from the symbol (R) before it moves to the 512 state Viterbi block. The Viterbi decoder produces the LSB (X0) of the received symbol. The R symbol is also sent to a delay and slicer block to recover the X[2:1] bits, completing the 3 bit vector. The delay block compensates for the delay of the Viterbi decoder.

Figure 16. FEC Decoder Block Diagram

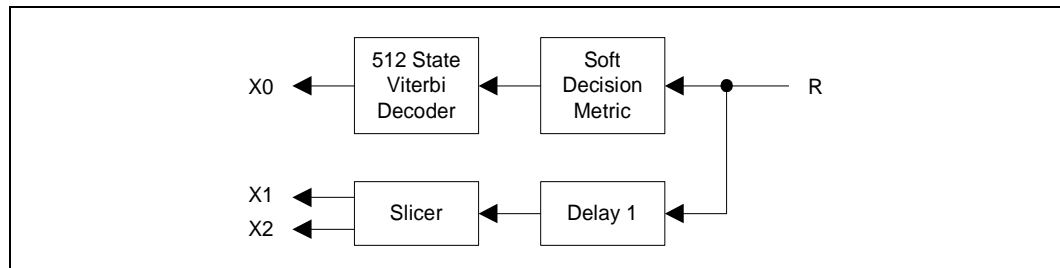

4.5 PAM Transmitter

ANSI HDSL2 utilizes a PAM 16 constellation. In addition to coded PAM, HDSL2 also employs other digital signal processing techniques. Pre-distortion is used to compensate for the attenuation on the line, while spectral shaping is necessary to control both self near-end crosstalk (NEXT) and crosstalk into other services. Figure 17 shows the PSD mask for ANSI HDSL2. The transmitter PSD template may be configured for either H2TU-R or H2TU-C operation through the MAIN0 register.

The PAM Transceiver and AFE work together to provide the D/A function. Data from the transmit filter is first passed through a multistage Delta-Sigma modulator. The modulator runs off the REFCLK input from the AFE and over-samples the data at approximately 48X. The output is a pulse width modulated data stream that is passed to the AFE across the DAC<3:0> interface. Transfers are synchronized with the rising edge of the REFCLK line. Subsequent filtering within the AFE removes quantization noise.

Figure 17. HDSL2 PSD Mask for North America

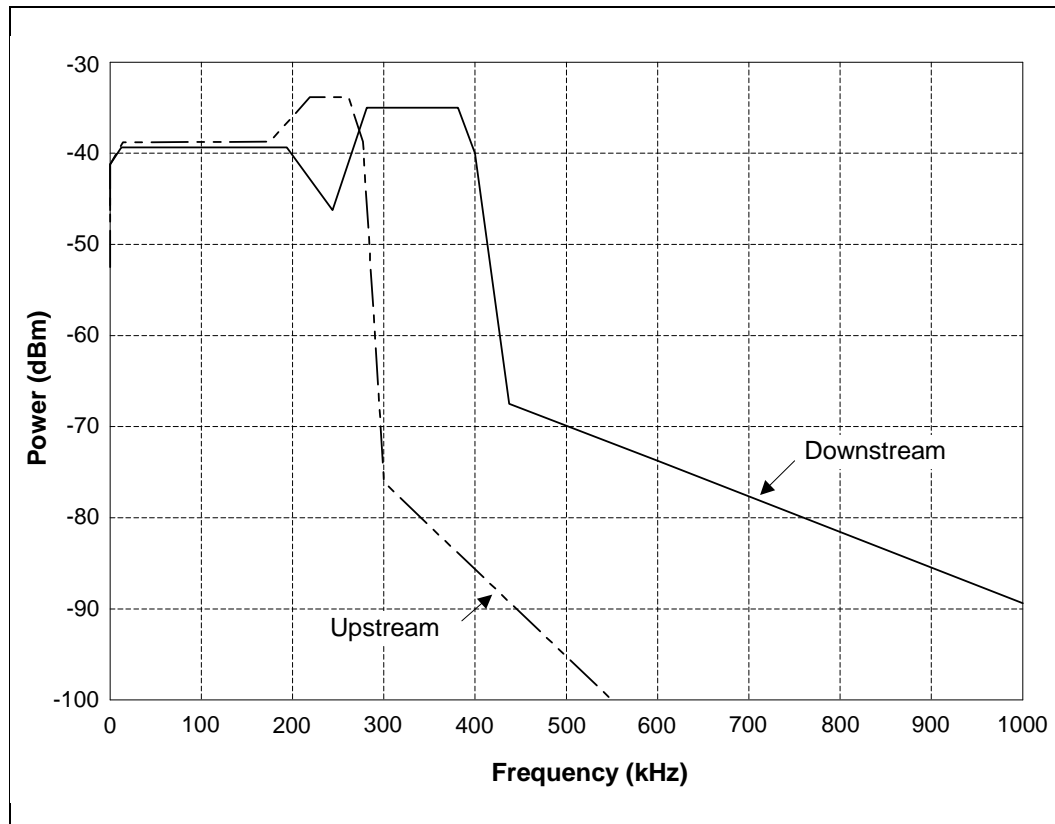

4.6 Receiver

The combined functions of the PAM Transceiver and the AFE provide the A/D function. A multistage Delta Sigma modulator in the AFE over-samples the incoming signal and produces a pulse width modulated data stream. The data is sent to the transceiver across the ADC<5:0> lines. Transfers are synchronized with the rising edge of the REFCLK line.

At the Transceiver input, a decimation filter removes out-of-band energy and effectively recovers the signal from the pulse width modulated input. Subsequent to the decimation filter, an Echo Cancellation (EC) block subtracts the transmitted signal from the received data path. The EC filter has a multi-tap structure and the coefficients are adjusted during the activation sequence. Once setup, the coefficients of the EC adaptively adjust to changes in the input signal.

While the Tomlinson precoder and transmit filter adjust for line attenuation and crosstalk, they cannot remove Inter-Symbol-Interference (ISI) due to imperfect channel characteristics. An adaptive Feed Forward Equalizer (FFE) is used to reduce ISI from the received data. The equalizer coefficients are updated every baud cycle for fast convergence and are based on an LMS algorithm. Soft decision symbols are subsequently passed to the FEC decoder.

4.7 Clock Generation

The SK70740/44 operates from a single crystal reference at the AFE. The AFE passes a reference clock (REFCLK) to the PAM Transceiver at half of the crystal frequency. A digital synthesizer in the Transceiver/Framer recovers the clock from the incoming signal and is used to generate the baud clock for the transmit signal. The timing recovery block also provides the timing signals for the digital signal processing and frame mapping functions. Digital timing recovery allows the system to operate the D/A and A/D converters with a fixed sampling rate derived from the crystal oscillators. It also facilitates the implementation of fractional rate service by allowing the system to support the sub-rates without replacing the crystal or scaling the clock frequency. The DSP system operates at a T/2 baud rate with the Delta Sigma modulators sampling the data at a fixed rate derived from the REFCLK. The relationship between REFCLK and baud rate may be a non-integer value. This provides flexibility and a low cost implementation.

The H2TU-C and H2TU-R utilize slightly different clock generation and recovery schemes. The crystal at the H2TU-C is the master reference for the loop. When the loop comes up, all timing is referenced to the master oscillator. During activation, the H2TU-R uses a local oscillator for a timing reference until the H2TU-R receiver can synchronize with the downstream data. The H2TU-R then synchronizes to the recovered symbol clock.

Figure 18. Clock Generation

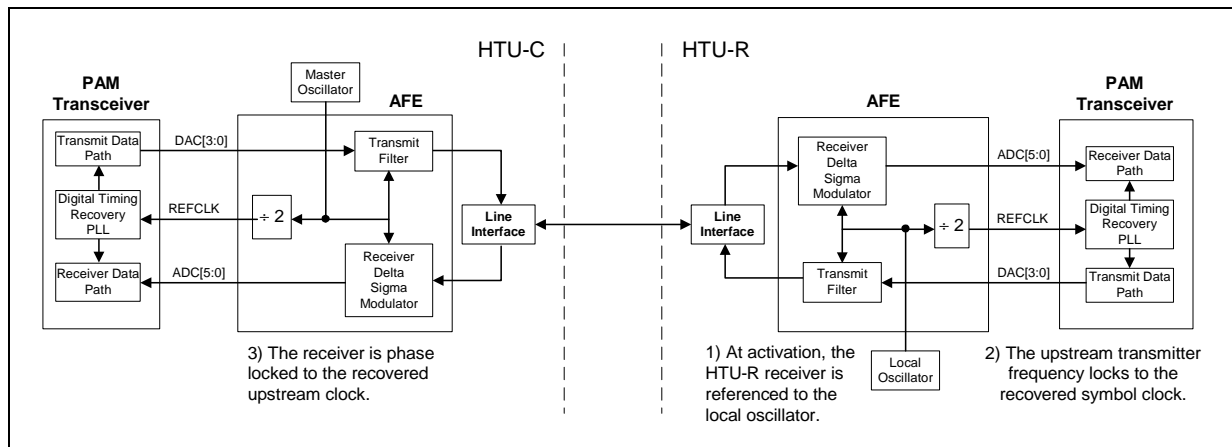

4.8 Noise Margin and SNR Estimation

The channel noise is estimated by comparing the soft decision data from the slicer, to the output of the Viterbi decoder. Typically, the noise power is estimated over a sequence of 128 symbols, however the resolution may be increased by averaging the noise over a longer symbol stream. The average signal power is based on the constellation size and the transmit power level. The FECNS register produces a noise estimate that is updated every symbol period. The system processor can use the FECNS data to compute the channel SNR.

4.9 Activation

The activation state machine is fully programmable through firmware. The line rate data fields for the pre-activation frame are written to program memory and downloaded during configuration. The memory locations can vary and are documented in each firmware release.

The primary activation and pre-activation is in accordance with the ANSI T1E1.418 specification.

The primary activation sequence is used to trade modem configuration details, train the transceiver echo canceller, train the adaptive equalization, and achieve frame synchronization. The pre-activation sequence is optional and may be implemented to negotiate the line rate and exchange power back-off information. Upon completion of the activation sequence, the transceiver enters the Active state and is ready to transmit data.

4.9.1 Pre-Activation

Pre-activation adds approximately 2 seconds to the standard activation time, and is a sub-set of the Activating state. During the pre-activation sequence, both modems characterize the line attenuation and noise margin (NM) at the receiver input. Algorithms in the system firmware then compute the appropriate PSD, which will be used during the standard activation. Based on the line characterization, the H2TU-C and H2TU-R both send a pre-activation frame to the transceiver at the opposite end of the line. The frame specifies the requested PSD mask. As shown in [Table 5](#), the pre-activation frame contains 20 bits and is transmitted LSB first. Each bit has a period of 10 +/- 0.5 msec. The back-off limits are linearly scaled in dB, by the Request Transmit Mask Number, to obtain the power back-off value. A transmit mask of zero would correspond to 0 dB of power back-off, while a requested PSD mask of 7 would correspond to a 7 dB back-off. If power back-off is disabled, the receiver will automatically transmit 0000 for the Request Transmit Mask Number.

The line rate is set in firmware by specifying the number of DS0 channels and Z bits in the HDSL2 frame. Note that the pre-activation sequence will not negotiate whether 2B1Q, PAM 8 or PAM 16 line code will be used. Instead, both the H2TU-C and H2TU-R should be pre-set for a specific line code and framing overhead. The user also has the option of using the unspecified bits in the normal activation frame to specify the modulation format.

Table 5. Pre-Activation Frame

Pre-Activation Frame Bit	Definition
1	Always set to a 1
2	Always set to a 0
3	CRC Error Indicator. If the received CRC indicates an error, then the modem will send a message back with bit 3 set to one.
4:7	Request Transmit Mask Number, rtm_1 - rtm_4 , rtm_1 is sent first.
8:13	Reserved
14:16	Number of Z bits per frame data block
17:20	CRC bits C_1 - C_4 , C_1 sent first

4.9.2 Primary Activation

At start-up, the Transceiver/Framer begins an activation sequence to synchronize the loop clocks and bring up the DSP blocks. The transceiver activation time is approximately 15 seconds and varies according to the application. Upon activation of the PAM transceivers, the VAL bit in the Interrupt State Register (INT_ST) is set to indicate to the system processor that the transceiver is ready to send and receive data.

There are two methods to initiate activation, depending whether the transceiver is configured for H2TU-C or H2TU-R operation. At the H2TU-R, the transceiver waits for an activation request (ACTREQ) from the microcontroller, before starting activation. At the H2TU-C, activation starts after detecting the presence of the signal on the line before starting activation.

The start-up procedure is always initiated by the H2TU-R. [Figure 19](#) shows a simplified state transition diagram. The associated times are described in [Table 6](#).

Figure 19. Simplified State Transition at Activation

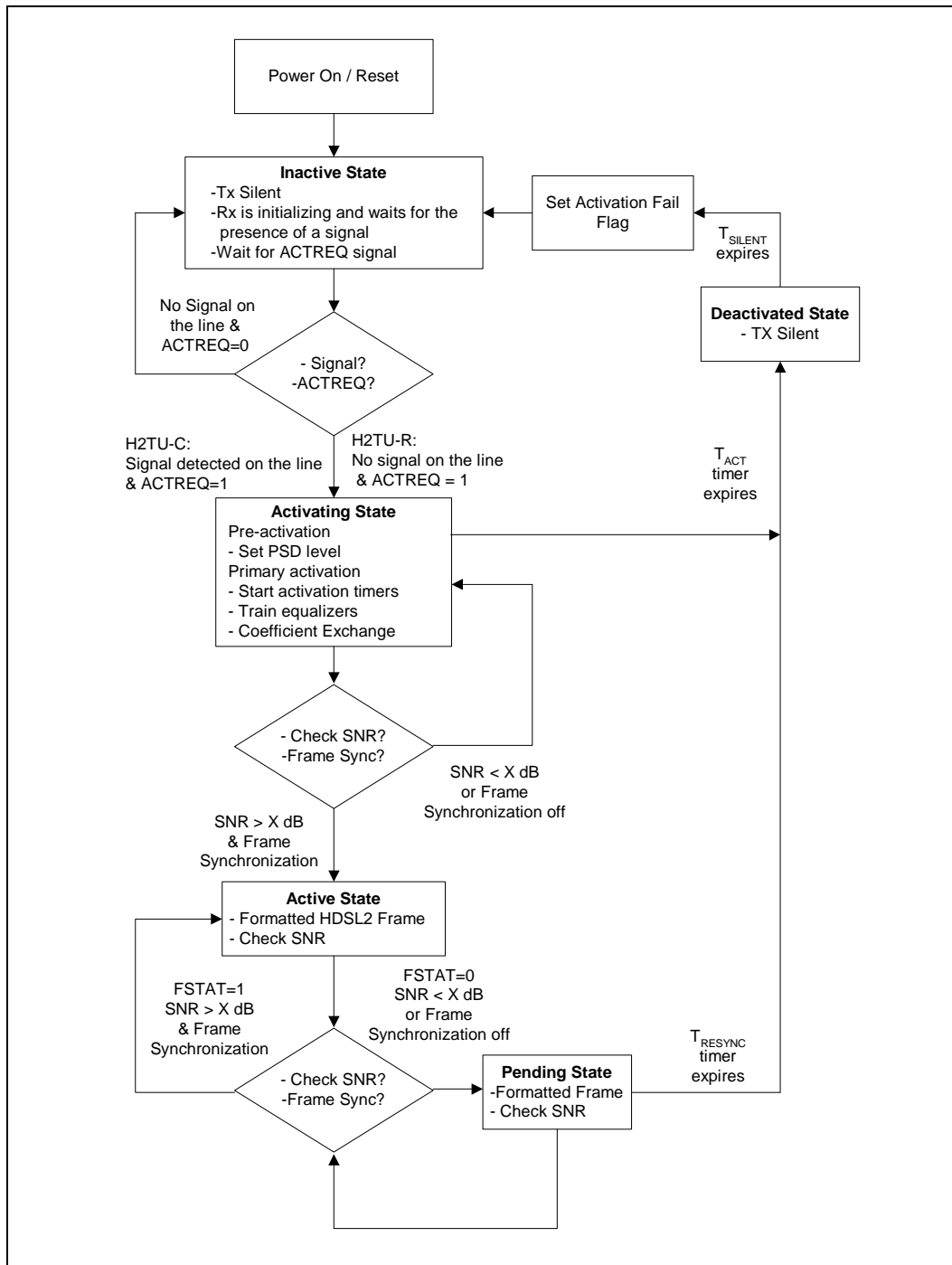

4.9.3 Inactive State

When the Transceiver/Framer is powered up and/or a \overline{RST} is applied, the transceiver enters the inactive state. When inactive, the transmitter is turned off, the receiver is ready to detect whether there is a signal on the line, and the transceiver waits for an activation request (ACTREQ) from the microcontroller. After receiving the activating request, the H2TU-C goes into the Activating State and begin the start-up sequence. After detecting the presence of a signal on the line, the H2TU-R also enters the Activating State and begins start-up. If none of these events occur, no signal is put on the loop to minimize unnecessary crosstalk.

4.9.4 Activating State

The H2TU-R starts the activation timer, T_{ACT} upon entering the Activating state and begins sending a scrambled 2 level signal. After receiving the signal from the H2TU-R, the H2TU-C, will wait T_{IDLE} and then begin sending signals downstream. Both H2TU-C and H2TU-R then begin an adaptive configuration of the Echo Canceler, Channel Estimator and Timing Recovery. After configuration, and when the transceiver is synchronized with the start of frame SYNC word, the system processor checks the SNR on the line, and sets FSTAT =1 if the SNR is acceptable.

4.9.5 Active State

In the active state, the transceiver functions are fully active and adaptive. Fully formatted HDSL2 frames are transmitted and received from both sides of the line. The noise margin is monitored and the system processor sets FSTAT=0 when the noise margin drops below an acceptable level, forcing the transceiver to enter the Pending state.

4.9.6 FSTAT

The FSTAT bit indicates that the system has both frame sync and sufficient noise margin. During the activation sequence, the system processor uses data from the FECNS register to calculate the SNR and noise margin. Upon reaching a user specified noise margin, the system processor will turn-on the frame mapper. When frame sync is achieved, the fsync bit in the HRFSR register will be set to 1. After synchronization, the processor will set the FSTAT bit in the FSTAT register to 1. Prior to moving to the Active state, the activation controller will verify that FSTAT is set to 1. Once Active, a 0 written to the FSTAT will move the transceiver into the Pending state.

4.9.7 Hold (Pending) State

When the FSTAT bit is set to '0', the Transceiver/Framer enters the Pending state and the T_{RESYNC} timer starts. If the line once again achieves acceptable noise margin, (indicated when FSTAT=1) the transceiver will return to the Active state. Otherwise, the T_{RESYNC} timer will expire causing the transceiver to:

- Set the Activation Fail flag in the Interrupt State Register
- Enter the Deactivated state

4.9.8 Deactivated State

In this state, the transceiver shuts off the transmitter for T_{SILENT} seconds and goes to the Inactive state. The deactivated state is required to avoid an erroneous signal detection in the Inactive State.

Table 6. Start-up Timers

Timer	Value (sec.)	Description
T _{ACT}	15	Activation Expiration Timer
T _{IDLE}	1	H2TU-R Idle Time before transmitting
T _{SILENT}	0.5	Silent time in Deactivated state
T _{RESYNC}	2	Time in Pending State before dropping to Deactive

4.9.9 Activating State Machine

Configuration of the transceiver signal processing blocks (transmit PSD, AGC, echo canceler, equalization, and timing recovery) takes place during the Activating state. The Activating state machine for the H2TU-C and H2TU-R are shown in Figure 20. Eleven signaling events are used during the activation process:

- Silent: No signal is transmitted on the line.
- A_T - Scrambled two-level PAM signal {-4,+4} used during pre-activation by the receiver of the H2TU-C to determine line attenuation and SNR
- B_C - Scrambled two-level PAM signal {-4,+4} transmitted with a 7 dB power back-off. Used during pre-activation by the H2TU-R to determine line attenuation and SNR.
- A_T' - Scrambled four-level PAM {-4, -9,+4, +9} that transfers the pre-activation frame to the H2TU-C
- B_C' - Scrambled four-level PAM {-4, -9,+4,+9} that transfers the pre-activation frame to the H2TU-R
- C_T - Scrambled two-level PAM {-9, +9} with the specified power back-off. Used to train the echo canceler at the H2TU-R.
- S_C - Scrambled two-level PAM {-9, +9} with the specified power back-off. Used to train the equalization at the H2TU-R
- S_T - Scrambled two-level PAM {-9, +9} with the specified power back-off. Used to train the equalization at the H2TU-C
- T_C - Scrambled two-level PAM {-9, +9} with the specified power back-off. Used to send the activation frame to the H2TU-R. Precoder coefficients for the H2TU-R are included in the activation frame.
- T_T - Scrambled two-level PAM {-9, +9} with the specified power back-off. Used to send the activation frame to the H2TU-C. Precoder coefficients for the H2TU-C are included in the activation frame.
- F_C - Scrambled two-level PAM {-9, +9} with the specified power back-off. Transmits “dummy” activation frame with a reversed frame sync word to signal to the H2TU-R to change to precoder mode.
- Data_C and Data_T - Scrambled 16 level PAM (+15, +13, +11, +9, +7, +5, +3, +1, -1, -3, -5, -7, -9, -11, -13 -15) with the specified power back-off.

Scrambler Polynomials:

- STU-C Scrambler = $x^{-23} + x^{-5} + 1$
- STU-C Descrambler = $x^{-23} + x^{+18} + 1$

- STU-R Scrambler = $x^{-23} + x^{-18} + 1$
- STU-R Descrambler = $x^{-23} + x^{-5} + 1$

4.10 Activation Frame

The Activation Frame is used to trade configuration data and precoder coefficients. The format of the Activation Frame is described in [Table 7](#). The Activation Frame is transmitted during the T_c and T_r signaling stage, after the signal processing blocks of the H2TU-C and H2TU-R have reached a steady state. The data fields for this activation frame are written to program memory and downloaded during configuration. The memory locations can vary and are documented with each firmware release.

In the receive path, both Feed Forward Equalization (FFE) and decision Feedback Equalization (DFE) may be used. However, the recursive nature of the DFE can cause bit errors to propagate into burst errors in the Viterbi decoder. Thus, when forward error correction is employed, transmit precoding is used to adjust for the line attenuation, rather than the DFE. During the Activating state, the transceivers are first trained using the DFE. The DFE coefficients are then sent to the modem at the opposite end of the line, to train the precoder. The H2TU-C and H2TU-R must know when the transmitters switch from the DFE mode to the Precoder mode. During the transmission of the F_c signal, a frame with a Reversed Sync Word (RSW) is transmitted to initiate the transition from DFE to Precoder mode. To initiate the transition, the H2TU-C sends 4 frames with RSW to indicate to the H2TU-R to switch on the precoder. The precoder of the H2TU-C switches on automatically.

After the transfer from DFE mode to Tomlinson precoder mode, the transceiver completes the start-up sequence and can then move into the Active state. The transceiver must detect either the multi-level $Data_c$ or $Data_r$ signals from the far end. The system processor must also turn on the frame mapper and indicate frame sync by setting the FSTAT bit in the FSTAT register. Once FSTAT=1, the transceiver may enter the Active state. The VAL bit is set to one in the Interrupt State register, indicating that the transceiver is operational.

Figure 20. Start-Up Sequence

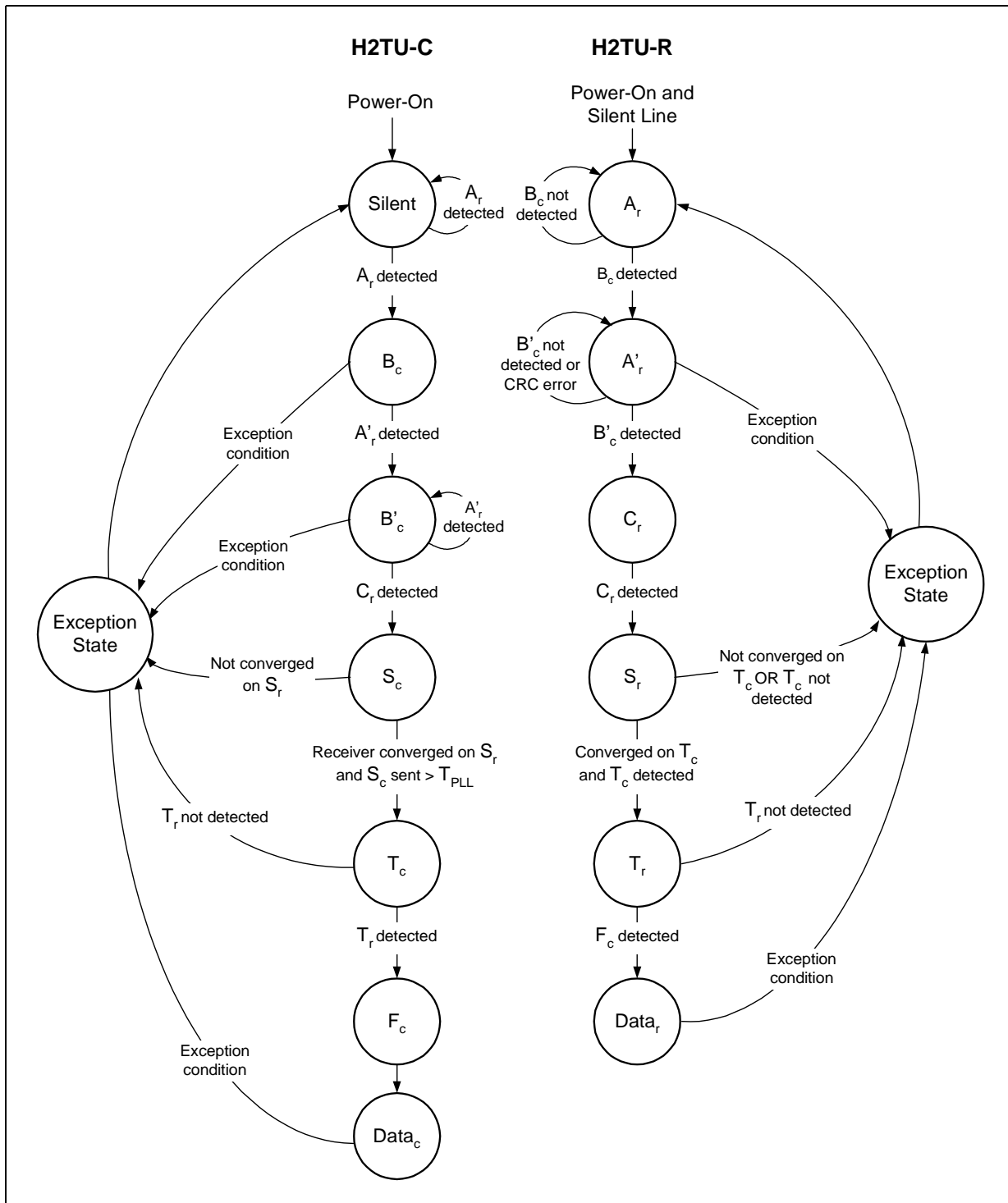

Table 7. Activation Frame Format (Optional)

Activation Frame Bits, LSB : MSB	Definition
1:13	Frame Sync. 1111100110101. Not scrambled. Left bit is sent first in time.
14:35	Precoder Coefficient 1. 22 bit signed two's complement format with 17 bits after the binary point, where the LSB is sent first in time.
36:57	Precoder Coefficient 2
58:3951	Precoder Coefficients 3 - 179
3952:3973	Precoder Coefficient 180
3874:3994	Encoder Coefficient A: 21 bits where the LSB is sent first in time.
3995:4015	Encoder Coefficient B: 21 bits where the LSB is sent first in time.
4016:4017	Size of country code in octets: 2 bits, where LSB is sent first in time
4018:4019	Size of manufacturers code in octets: 2 bits, where LSB is sent first in time
4020:4051	Country Code Word: 32 bits Max where the LSB is sent first in time. Any unused bits follow the MSB and are set to zero.
4052:4083	Manufacturer Code Word: 32 bits Max where the LSB is sent first in time. Any unused bits follow the MSB and are set to zero.
4084:4147	Vendor Data: 64 bits of proprietary information.
4148:4155	Version of HDSL2 standard.
4156:4159	Stuff bit values, sb1-sb4, where sb1 is sent first in time.
4160:4169	Frame Sync Word, FSW1-FSW0, where FSW1 is sent first in time.
4170:4173	PSD mask value transmitted, tm1-tm4, where tm1 is sent first in time.
4174:4211	Reserved 38 bits set to logical 0
4212:4227	CRC: bit 15 is sent first and bit 0 is sent last in time

4.11 Power Down

When inactive, the Transceiver/Framer Power Down mode may be used to conserve power. The Power Down mode is selected when the PDNB bit = 0 (PLL_CTL register). To reactivate the Transceiver/Framer, set the PDNB bit = 1 and reset the PLL by toggling the RSTB bit (PLL_CTL register). A device reset should then be performed by either toggling the $\overline{\text{RST}}$ bit (MAIN0 register), or pulsing the $\overline{\text{RST}}$ pin Low.

4.12 Loopbacks

Transceiver/Framer provides three loopback configurations:

- DSL Interface - Data at ADC[5:0] is sent directly to DAC[3:0]
- Data Interface - Data at TSER is sent directly to RSER. Likewise, TCLK is sent to RCLK and TFSYNC is sent to RFSYNC.
- Framer Interface - HDSL2 framed data is sent back through the receive channel to the data interface.

4.13 Microprocessor Interface

The microprocessor interface provides access to internal control and status registers. The interface may be configured for either Motorola 68000 series or Intel 80C51 series microprocessors. The configuration of the interface is set by the I/M (Intel/Motorola) pin.

Figure 21. System Loopback Options

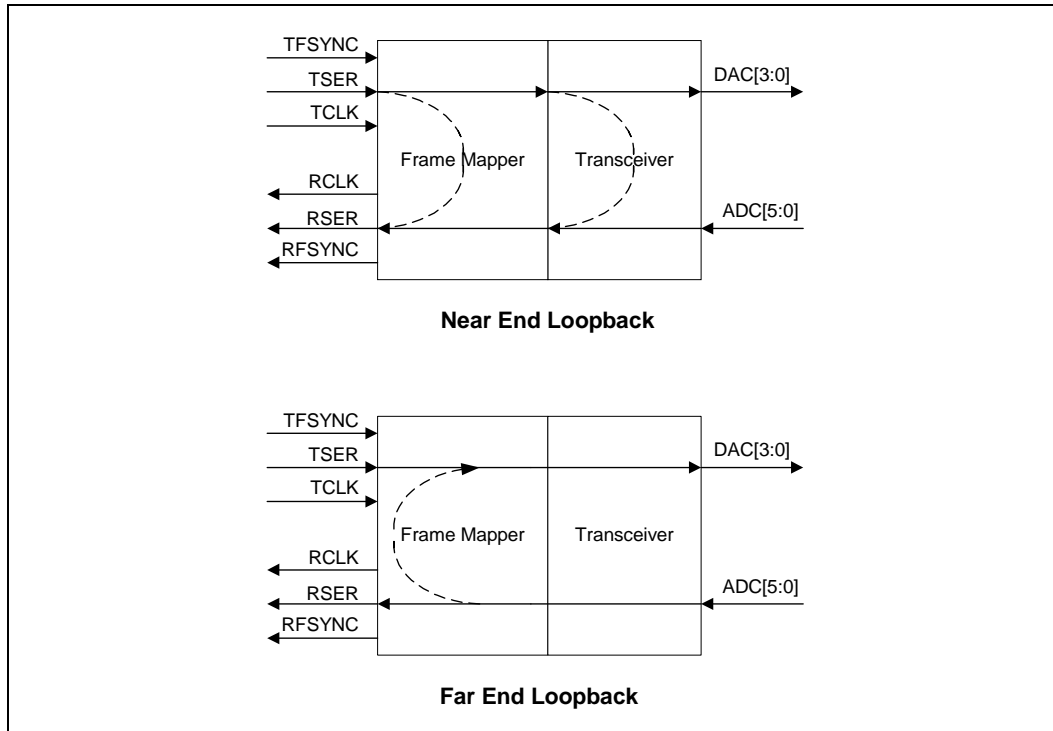

5.0 Register Definitions

The SK70740/44 registers are accessed by the system processor through the microprocessor interface. Upon reset, the registers are set to the default values shown in each register description table. Note that none of the registers, except PLL_CTL (30h), can be accessed until the master clock is enabled in the PLL_CTL register.

Some registers contain “reserved” bits which the user’s software must consider. For reads, the software must use appropriate masks to extract the defined bits and not rely on reserved bits being any particular value. In some cases, the software must program reserved bit positions to particular values. If applicable, reserved values are specified in the register description tables.

5.1 AFE Registers

The AFE contains 2 registers (AR1 and AR2) which configure its operating parameters. Note that the AFE registers are not directly accessible, but rather, are accessed via PAM Transceiver registers: AFE_CTL (0Ah), AFE_ADD (0Bh), and AFE_STAT (2Dh).

A write to AFE_CTL followed by a write to AFE_ADD, with the R/W bit set to ‘0’, will transfer the contents of AFE_CTL to the AFE register specified by AFE_ADD. Likewise, a write to AFE_ADD, with the R/W bit set to ‘1’, will retrieve the data from the register specified by AFE_ADD, and place the data in AFE_STAT.

To ensure the integrity of AFE register data observe the following:

- Before changing data in AFE_CTL, set the R/W bit in AFE_ADD to ‘1’ (read).
- Wait 2 symbol periods between successive write operations.
- Wait 3 symbol periods between successive read operations.

Table 8. AFE Control Register 1, AR1, R/W, Address = 00h, Default = 00h

Bit	Name	Description
7	RESET	Resets all registers and A/D integrators.
6	PWDN	Set to ‘1’ to power-down the transmitter and receiver sections of the AFE. Core support circuits (e.g. bandgap, Ebias and Xosc) remain powered-up to support clock generation.
5	ALOOPTX	Set to ‘1’ to enable Analog loopback from TTIP/TRING pins. Transmit data is looped back to Rx ADC and also sent to the transmit line driver.
4	ALOOPSC	Set to ‘1’ to enable Analog loopback from SCF output. Analog loopback to the receiver is provided from the output of SCF, and is useful during DAC calibration mode. To prevent the calibration signal from being transmitted on the line, set the TBHIGHZ bit.
3	TBHIGHZ	Transmit Buffer in high impedance mode. Setting this bit shuts down the transmit buffer. This bit should be set to disable data transmission on line (during activation) or to power down the output buffer.

Table 8. AFE Control Register 1, AR1, R/W, Address = 00h, Default = 00h (Continued)

Bit	Name	Description
2	TBLDHIMP	Transmit Buffer Load is high impedance. Default mode (TBLDHIMP = 0) assumes transmit buffer has to drive a load as low as 500 Ω. If the line driver interface to transmit buffer is high Z (> 10k Ω), then this bit should be set. This reduces transmit buffer power consumption significantly while maintaining linearity.
1	HTUR	Sets the transmit filter for either upstream or downstream transmission. Set to '1' for upstream (H2TU-R) operation. Set to '0' for downstream (H2TU-C).
0	T1SEL	Set to '0' for normal operation.

Table 9. AFE Control Register 2, AR2, R/W, Address = 01h, Default = 00h

Bit	Name	Description																																				
7	RCAL	Receive A/D Offset Calibration. Setting this bit shorts the receiver inputs together to measure the offset voltage from the A/D opamps.																																				
6	RRESET	Resets the A/D converter integrators.																																				
<5:3>	RINT2:0>	Selects integrator for overrange status output as follows:																																				
		<table border="1"> <thead> <tr> <th>RINT[2]</th> <th>RINT[1]</th> <th>RINT[0]</th> <th>Output Selected from Integrator</th> </tr> </thead> <tbody> <tr> <td>0</td> <td>0</td> <td>0</td> <td>Logical OR of all 6 integrator overrange detects.</td> </tr> <tr> <td>0</td> <td>0</td> <td>1</td> <td>Logical OR of all 6 integrator overrange detects.</td> </tr> <tr> <td>0</td> <td>1</td> <td>0</td> <td>5</td> </tr> <tr> <td>0</td> <td>1</td> <td>1</td> <td>4</td> </tr> <tr> <td>1</td> <td>0</td> <td>0</td> <td>3</td> </tr> <tr> <td>1</td> <td>0</td> <td>1</td> <td>2</td> </tr> <tr> <td>1</td> <td>1</td> <td>0</td> <td>1</td> </tr> <tr> <td>1</td> <td>1</td> <td>1</td> <td>0</td> </tr> </tbody> </table>	RINT[2]	RINT[1]	RINT[0]	Output Selected from Integrator	0	0	0	Logical OR of all 6 integrator overrange detects.	0	0	1	Logical OR of all 6 integrator overrange detects.	0	1	0	5	0	1	1	4	1	0	0	3	1	0	1	2	1	1	0	1	1	1	1	0
		RINT[2]	RINT[1]	RINT[0]	Output Selected from Integrator																																	
		0	0	0	Logical OR of all 6 integrator overrange detects.																																	
		0	0	1	Logical OR of all 6 integrator overrange detects.																																	
		0	1	0	5																																	
		0	1	1	4																																	
		1	0	0	3																																	
		1	0	1	2																																	
1	1	0	1																																			
1	1	1	0																																			
<2:0>	RAGC<2:0>	Sets the gain of the receive A/D input stage as follows:																																				
		<table border="1"> <thead> <tr> <th>RAGC[2]</th> <th>RAGC[1]</th> <th>RAGC[0]</th> <th>AGC Gain</th> </tr> </thead> <tbody> <tr> <td>0</td> <td>0</td> <td>0</td> <td>-18 dB</td> </tr> <tr> <td>0</td> <td>0</td> <td>1</td> <td>-15 dB</td> </tr> <tr> <td>0</td> <td>1</td> <td>0</td> <td>-12 dB</td> </tr> <tr> <td>0</td> <td>1</td> <td>1</td> <td>-9 dB</td> </tr> <tr> <td>1</td> <td>0</td> <td>0</td> <td>-6 dB</td> </tr> <tr> <td>1</td> <td>0</td> <td>1</td> <td>-3 dB</td> </tr> <tr> <td>1</td> <td>1</td> <td>0</td> <td>0 dB</td> </tr> <tr> <td>1</td> <td>1</td> <td>1</td> <td>+3 dB</td> </tr> </tbody> </table>	RAGC[2]	RAGC[1]	RAGC[0]	AGC Gain	0	0	0	-18 dB	0	0	1	-15 dB	0	1	0	-12 dB	0	1	1	-9 dB	1	0	0	-6 dB	1	0	1	-3 dB	1	1	0	0 dB	1	1	1	+3 dB
		RAGC[2]	RAGC[1]	RAGC[0]	AGC Gain																																	
		0	0	0	-18 dB																																	
		0	0	1	-15 dB																																	
		0	1	0	-12 dB																																	
		0	1	1	-9 dB																																	
		1	0	0	-6 dB																																	
		1	0	1	-3 dB																																	
1	1	0	0 dB																																			
1	1	1	+3 dB																																			

5.2 Transceiver/Framer Registers

Table 10 shows the functional mapping of the Transceiver/Framer registers. Table 11 provides a summary of the Transceiver/Framer registers. Table 12 through Table 71 provide detailed bit descriptions of each register.

Table 10. Transceiver/Framer Register Categories

Address Range (hex)	Function
00 - 32	PAM Transceiver
80 - 9F	Forward Error Correction (FEC)
A0 - B4	Framer Transmit
C0 - DE	Framer Receive
D6 - FF	Reserved

Table 11. Transceiver/Framer Register Summary

Addr (hex)	Register Label	Read / Write	Definition	Page #
PAM TRANSCIEVER REGISTERS				
00	MAIN 0	R/W	Main Control Register 0	51
01	MAIN 1	R/W	Main Control Register 1	52
02	ACT_MODE	R/W	Activation Mode Control Register	52
03-09	-	-	Reserved ¹	-
0A	AFE_CTL	R/W	Analog Front End (AFE) Control Register	52
0B	AFE_ADD	R/W	AFE Address Register	52
0C	INT_MSK	R/W	Interrupt Mask Register	53
0D	INT_ST	R/W	Interrupt State Register	53
0E	HW_CFG	R	Hardware Configuration Register	53
0F-17	-	-	Reserved ¹	-
18	RATE_SEL0	R/W	Rate Selection Register 0	54
19	RATE_SEL1	R/W	Rate Selection Register 1	54
1A	RATE_SEL2	R/W	Rate Selection Register 2	54
1B-21	-	-	Reserved ¹	-
22	TRSTAT	R	TIP/RING Reversal Status Register (read only)	54
23-24	-	-	Reserved ¹	-
25	FSTAT	R/W	Framer Status Register	54
26-2C	-	-	Reserved ¹	-
2D	AFE_STAT	R/W	AFE Status Register	55
2E	SFT0	R/W	Soft Decision LSB	55
2F	SFT1	R/W	Soft Decision MSB	55

1. Do not write to reserved register

Table 11. Transceiver/Framer Register Summary (Continued)

Addr (hex)	Register Label	Read / Write	Definition	Page #
30	PLL_CTL	R/W	PLL Control Register	55
31	MAIN2	R/W	Main Control Register 2	55
32	MISC1	R/W	Miscellaneous Control Register	56
33	HTMCR	R/W	Wander Reduction Control Register	56
34-7F	-	-	Reserved ¹	-
FEC REGISTERS				
80	CGSEL	R/W	Code Generator Select Register	56
81- 83	CG1-3	R/W	FEC Code Generator	57
84	FECTB	R/W	Viterbi Decoder Trace Back Depth	57
85	FECNS	R	FEC Noise Register	58
86-92	-	-	Reserved ¹	-
93	FECCR		FEC Control Register	58
84-9F	-	-	Reserved ¹	-
FRAMER TRANSMIT REGISTERS				
A0	PLRATE	R/W	Payload Bit Rate	58
A1	HTFWL	R/W	Reference Water Level for Transmit FIFO	59
A2	TFWL	R	Actual Water Level for Transmit FIFO	59
A3	HTFCR	R/W	Transmit Control Register	59
A4	HTFTCR	R/W	Transmit Test Control Register	59
A5	HTFBSR	R/W	Data Byte Selector Register	60
A6	HTFRSRH	R	Data Read Sample Register (high byte)	60
A7	HTFRSRL	R	Data Read Sample Register (low byte)	60
A8	HTFTMR	R/W	Transmit Mode and DSL Frame Control Register	60
A9	HTFFSW1	R/W	Frame Sync Word (FSW), first 8 bits	61
AA	HTFFSW2	R/W	Frame Sync Word (FSW), last 2 bits	61
AB-B0	-	-	Reserved ¹	-
B1	HTFHOH1	R/W	Transmit HDSL2 Overhead Register 1	62
B2	HTFHOH2	R/W	Transmit HDSL2 Overhead Register 2	62
B3	HTFHOH3	R/W	Transmit HDSL2 Overhead Register 3	62
B4	HTFHOH4	R/W	Transmit HDSL2 Overhead Register 4	63
B5-BF	-	-	Reserved ¹	-
FRAMER RECEIVE REGISTERS				
C0	HRFCR	R/W	Receive Control Register	63
C1	HRFTCR	R/W	Receive Test Control Registers	64
C2	HRFWL	R	Receive FIFO Water Level Register	64
1. Do not write to reserved register				

Table 11. Transceiver/Framer Register Summary (Continued)

Addr (hex)	Register Label	Read / Write	Definition	Page #
C3	HRFFDR	R	Receive FIFO Depth Register	64
C4	HRFSR	R	Receive Status Register	65
C5	HRFTTCR	R/W	Timing and Loopback Control Register	65
C6	HRFNCR1	R/W	NCO Control Register, MSB	66
C7	HRFNCR2	R/W	NCO Control Register, LSB	66
C8	-	-	Reserved ¹	-
C9	HRFCRC	R	CRC Error Counter Register	67
CA	HRFPAJ	R/W	DPLL Phase Adjustment Register	66
CB	HRFPAC	R	DPLL Clock Division Ratio Register	66
CC-D1	-	-	Reserved ¹	-
D2	HRFHOH1	R	Receive HDSL2 Overhead Register 1	67
D3	HRFHOH2	R	Receive HDSL2 Overhead Register 2	67
D4	HRFHOH3	R	Receive HDSL2 Overhead Register 3	67
D5	HRFHOH4	R	Receive HDSL2 Overhead Register 4	68
D6 - DC	-	-	Reserved ¹	-
DD	HRFFSW1	R/W	Receive Frame Sync Word (First 8 bits)	68
DE	HRFFSWSB	R/W	Receive Frame Sync Word (Last 2 bits) & Stuff Bits	68
DF - FF	-	-	Reserved ¹	-

1. Do not write to reserved register

5.3 PAM Transceiver Registers

Table 12. Main Control Register 0, MAIN0, R/W, Address = 00h, Default = 00h

Bit	Name	Description
7	$\overline{\text{RST}}$	Reset Bit: 0 = soft reset of all transceiver blocks; equivalent to performing a hardware reset via the $\overline{\text{RST}}$ pin. Note that the parallel microcontroller port remains active during soft reset.
6	ACTREQ	Activation Request Bit: Set to '1' to initiate self activation of the Transceiver/Framer.
5	C_or_R	H2TU-C mode = '1'; H2TU-R mode = '0'.
4	rs	Reserved. Must be set to '0'.
3	XTM	Timing H2TU-C (Master) Mode = '1'; Timing H2TU-R (Slave) Mode = '0'.
<2:0>	SM<2:0>	Serial Loopback Mode select: 000 = Normal Operation 010 = Internal data path loopback; Tx to Rx All other values are reserved.

Table 13. Main Control Register 1, MAIN1, R/W Address = 01h, Default = 20h

Bit	Name	Description										
<7:6>	FEC_CTL	FEC Control bits. Map directly to the 2 LSB's of the FEC_RX data stream.										
5	SYM_MAP	1 = symbol mapping enabled.										
4	rs	Reserved. Must be set to '0'.										
3	rs	Reserved. Must be set to '1'.										
2	rs	Reserved. Must be set to '0'.										
<1:0>	SLI	Slicer control: applicable to both DFE and Tomlinson modes of operation: <table border="1"> <thead> <tr> <th>SLI</th> <th>Slice</th> </tr> </thead> <tbody> <tr> <td>00</td> <td>±9</td> </tr> <tr> <td>01</td> <td>±15,13,11,9,7,5,3,1</td> </tr> <tr> <td>10</td> <td>±7, 5, 3, 1</td> </tr> <tr> <td>11</td> <td>0</td> </tr> </tbody> </table>	SLI	Slice	00	±9	01	±15,13,11,9,7,5,3,1	10	±7, 5, 3, 1	11	0
SLI	Slice											
00	±9											
01	±15,13,11,9,7,5,3,1											
10	±7, 5, 3, 1											
11	0											

Table 14. Activation Mode Control Register, ACT_MODE, R/W, Address = 02h, Default = 00h

Bit	Name	Description
<7:0>	AMC	This register specifies the activation state of the activation controller.

5.3.1 Registers 03h through 09h are Reserved

Table 15. AFE Control Register, AFE_CTL, R/W, Address 0Ah, Default = FFh

Bit	Name	Description									
<7:0>	D<7:0>	AFE Register Write Data. The AFE register bits are described in Table 8 and Table 9 on page 48.									
		Reg	Addr (hex)	B7	B6	B5	B4	B3	B2	B1	B0
		AR1	00	RESET	PWDN	ANLOOP	XEXCLK	TBHIGHZ	TBLDHIMP	H2TUR	T1SEL
	AR2	01	RCAL	RRESET	RINT[2]	RINT[1]	RINT[0]	RAGC[2]	RAGC[1]	RAGC[0]	
1. See "AFE Registers" on page 47 for register access information.											

Table 16. AFE Address Register, AFE_ADD¹, R/W, Address = 0Bh, Default = 80h

Bit	Name	Description						
7	R/WRB	0 = write to AFE; 1 = read from AFE						
<6:0>	D<6:0>	AFE Register Address. Selects the address of the AFE registers as follows:						
		<table border="1"> <thead> <tr> <th>Address</th> <th>AFE Register Name</th> </tr> </thead> <tbody> <tr> <td>00 0000</td> <td>AR1</td> </tr> <tr> <td>00 0001</td> <td>AR2</td> </tr> </tbody> </table>	Address	AFE Register Name	00 0000	AR1	00 0001	AR2
		Address	AFE Register Name					
		00 0000	AR1					
00 0001	AR2							
All other addresses are reserved								
1. See "AFE Registers" on page 47 for register access information.								

Table 17. Interrupt Mask Register, INT_MSK¹, R/W, Address = 0Ch, Default = FFh

Bit	Name	Description
7	rs	Reserved. Must be set to '1'.
6	rs	Reserved. Must be set to '1'.
5	rs	Reserved. Must be set to '1'.
4	VAL	Transceiver operational (Active state)
3	rs	Reserved. Must be set to '1'.
2	FAIL	Activation failed flag
1	rs	Reserved. Must be set to '1'.
0	rs	Reserved. Must be set to '1'.

1. A logic 1 represents a masked condition. A logic zero is unmasked. Setting the mask bits prevents the corresponding interrupt, in the Interrupt State Register, from affecting the INT output.

Table 18. Interrupt State Register, INT_ST¹, R/W, Address = 0Dh, Default = 00h

Bit	Name	Description
7	rs	Reserved. Must be set to '1'.
6	rs	Reserved. Must be set to '1'.
5	rs	Reserved. Must be set to '1'.
4	VAL	Transceiver operational (Active state)
3	rs	Reserved. Must be set to '1'.
2	FAIL	Activation failed flag
1	rs	Reserved. Must be set to '1'.
0	rs	Reserved. Must be set to '1'.

1. A logic 1 represents an interrupt condition for the respective bit if the corresponding mask bit is unmasked (mask=0). A logic 0 is the non-interrupt condition. Setting the mask bits prevents the corresponding interrupt bit from affecting the INT output pin. The interrupt bits are "sticky" in that the activation controller can only set the bits to logic '1'. An interrupt bit is cleared only when the microcontroller writes a logic '1' to the bit position.

Table 19. Hardware Configuration Register, HW_CFG, R, Address = 0Eh, Default = F0h

Bit	Name	Description
<7:4>	REV<7:4>	Chip revision number. Consult factory for current revision value. 0000
<3:0>	ID<3:0>	Part identification number. SK70744 - 0000

5.3.2 Registers 0Fh through 17h are Reserved

Table 20. Rate Select 0 Register, RATE_SEL0, R/W, Address = 18h, Default = AAh

Bit	Name	Description
<7:0>	D<7:0>	Set to C5h.

Table 21. Rate Select 1 Register, RATE_SEL1, R/W, Address = 19h, Default = AAh

Bit	Name	Description
<7:0>	D<7:0>	Set to 1Dh.

Table 22. Rate Select 2 Register, RATE_SEL2, R/W, Address = 1Ah, Default = ABh

Bit	Name	Description
<7:0>	D<7:0>	Set to B4h.

5.3.3 Registers 1Bh through 21h are Reserved

Table 23. TIP/RING Reversal, TIP/RING, R, Address = 22h, Default = 00h

Bit	Name	Description
7	rs	Reserved
6	TRSTAT	Tip/Ring reversal status. Set to '1' when a tip/ring reversal is detected.
<5:0>	rs	Reserved

5.3.4 Registers 23h and 24h are Reserved

Table 24. Framers Status Register, FSTAT, R/W, Address = 25h, Default = 00h

Bit	Name	Description
7	FSTAT	External framer status input. The system microcontroller should set this bit to '1' to indicate the framer is in sync and the SNR is acceptable, or set to '0' to begin the 2 second deactivation timer. Note that if FSTAT is not set to '1' before the 2 second timer expires, the transceiver will deactivate. '1' = good SNR and frame sync '0' = low SNR and loss of frame sync
<6:0>	rs	Reserved. Must be set to '0'.

5.3.5 Registers 26h through 2Ch are Reserved

Table 25. AFE Status Register, AFE_STAT, R/W, Address = 2Dh, Default = 00h

Bit	Name	Description
<7:0>	D<7:0>	Data read from AFE registers.
1. See "AFE Registers" on page 47 for register access information.		

Table 26. Soft Decision (LSB) Register, SFT0, R, Address = 2Eh, Default = 00 h

Bit	Name	Description ¹
<7:0>	SFT<7:0>	LSB of Soft Decision Data
1. This register contains the received soft decision. The format is 2's complement with 7 bits of fractional data.		

Table 27. Soft Decision (MSB) Register, SFT1, R, Address = 2Fh, Default = 00h

Bit	Name	Description ¹
<7:0>	SFT<15:8>	MSB of Soft Decision Data
1. This register contains the received soft decision. The format is 2's complement with 7 bits of fractional data.		

Table 28. PLL Control Register, PLL_CTL, R/W, Address = 30h, Default = 00h

Bit	Name	Description
7	rs	Reserved. Must be set to '0'
6	PDNB	0 = power down
5	RSTB	0 = reset
4	rs	Reserved. Must be set to '0'
<3:2>	PLLO	00 = Internal master clock = 4x REFCLK 01 = Reserved 10 = Reserved 11 = Reserved
1	rs	Reserved. Must be set to '0'
0	rs	Reserved. Must be set to '0'

Table 29. Main Control Register 2, MAIN2, R/W, Address = 31h, Default = 01h

Bit	Name	Description
<7:2>	rs	Reserved. Must be set to '0'
1	PRAM_EXE	'1' = DSP parameters executed from programmable RAM '0' = DSP parameters executed from ROM
0	RST_ACT	Set to '1' to reset activation controller

Table 30. Miscellaneous Control Register 1, MISC1, R/W, Address = 32h, Default = 00h

Bit	Name	Description
<7:6>	rs	Reserved.
5	FRSET	Framer reset. Set to '1' the reset the framer software.
<4:3>	PLLDIV	Phase lock loop divide factor: 00 = Normal operation 01 = Divide by 2 10 = Divide by 4 11 = PLL shut off
<2:0>	rs	Reserved.

Table 31. Wander Reduction Control Register, HTMCR, R/W, Address = 33h, Default = 00h

Bit	Name	Description
<7:0>	MTIE	Set to 88h for normal operation.

5.3.6 Registers 34h through 7Fh are Reserved

5.4 FEC Registers

5.4.1 FEC Encoder/Decoder Configuration Registers

The CGSEL register controls the FEC encoder/decoder loopback and enables programming of the encoder or decoder using CG1, CG2 and CG3. The CG1, CG2 and CG3 registers specify the a and b coefficients for the decoder and the 20-tap convolutional encoder. A diagram of this encoder is shown in [Figure 15 on page 35](#).

Table 32. Code Generator Select, CGSEL, R/W, Address = 80h, Default = 00h

Bit	Name	Description
<7:2>	rs	Reserved. Must be set to '0' when written.
2	fecloop	1 = loopback from encoder output to decoder input.
<1:0>	cgsel	Selection of code generator for encoder and decoder: 00 = Program decoder $a_9 - a_0$ and $b_9 - b_0$ using CG1, CG2 and CG3. 10 = Program encoder $a_{20} - a_0$ using CG1, CG2 and CG3. 11 = Program encoder $b_{20} - b_0$ using CG1, CG2 and CG3.

Table 33. Code Generator 1, CG1, R/W, Address = 81h, Default = DAh

Bit	Name	Description
<7:4>	rs	Reserved. Must be '0' when written.
<3:0>	cg	Code generator bits: When cgsel = 00, program decoder: bit7 =a ₇ , bit6=a ₆ , bit5=a ₅ , bit4=a ₄ , bit3=a ₃ , bit2=a ₂ , bit1=a ₁ , bit0=a ₀ When cgsel = 10, program encoder: bit7 = a ₇ , bit6=a ₆ , bit5=a ₅ , bit4=a ₄ , bit3=a ₃ , bit2=a ₂ , bit1=a ₁ , bit0=a ₀ . When cgsel = 11, program encoder: bit7 = b ₇ , bit6=b ₆ , bit5=b ₅ , bit4=b ₄ , bit3=b ₃ , bit2=b ₂ , bit1=b ₁ , bit0=b ₀ .

Table 34. Code Generator 2, CG2, R/W, Address = 82h Default = CDh

Bit	Name	Description
<7:0>	cg	Code generator bits When cgsel = 00, program decoder: bit7=b ₅ , bit6=b ₄ , bit5=b ₃ , bit4=b ₂ , bit3=b ₁ , bit2=b ₀ , bit1 =a ₉ , bit0=a ₈ . When cgsel = 10, program encoder: bit7 = a ₁₅ , bit6=a ₁₄ , bit5=a ₁₃ , bit4=a ₁₂ , bit3=a ₁₁ , bit2=a ₁₀ , bit1=a ₉ , bit0=a ₈ . When cgsel = 11, program encoder: bit7 = b ₁₅ , bit6=b ₁₄ , bit5=b ₁₃ , bit4=b ₁₂ , bit3=b ₁₁ , bit2=b ₁₀ , bit1=b ₉ , bit0=b ₈ .

Table 35. Code Generator 3, CG3, R/W, Address = 83h, Default = 08h

Bit	Name	Description
<7:0>	cg	Code generator bits When cgsel = 00, program decoder: bit7 - bit4 must be set to '0', bit3=b ₉ , bit2=b ₈ , bit1=b ₇ , bit0=b ₆ When cgsel = 10, program encoder: bit7 - bit5 must be set to '0', bit4=a ₂₀ , bit3=a ₁₉ , bit2=a ₁₈ , bit1=a ₁₇ , bit0=a ₁₆ . When cgsel = 11, program encoder: bit7 - bit5 must be set to '0', bit4=b ₂₀ , bit3=b ₁₉ , bit2=b ₁₈ , bit1=b ₁₇ , bit0=b ₁₆ .

Table 36. FEC Trace Back, FECTB, R/W, Address = 84h, Default = 00h

Bit	Name	Description
<7:5>	rs	Reserved. Must be set to 0 when written.
<4:0>	fectb	Trace back depth of the Viterbi Decoder = fectb[4:0] x 4. Note that fectb is an integer ranging from 0 to 16. The maximum trace back length is 64. A lower trace back can reduce latency with a trade-off in coding gain.

5.4.2 FEC Noise Register

The FECNS register provides a noise estimate based on a comparison of the soft decision data to the output of the Viterbi decoder. The 8 bit format is 3 integer bits and 5 fractional bits ($2^1, 2^0, 2^{-1}, 2^{-2}, 2^{-3}, 2^{-4}, 2^{-5}$) in the range of -4 and +4. The system microprocessor can average the 2's

complement of the FECNS register to determine the average noise power. The average FECNS value is then compared to the average signal power to determine the system SNR. For a PAM 16 constellation, the relationship is:

$$\text{SNR} = 10 \log \frac{85}{\frac{1}{n} \sum_1^n (\text{FECNS})^2}$$

85 is the variance of the PAM 16 constellation (+15, +13, +11..... -11, -13, -15). Typically the power is estimated over 128 symbols, however, resolution can be increased if the noise is averaged over a longer symbol stream.

Table 37. FEC Noise, FECNS, R, Address = 85h

Bit	Name	Description
<7:0>	fecns	FEC slicer error. Can be used by the microcontroller to compute channel SNR as described above.

5.4.3 Registers 86h through 92h are Reserved

Table 38. FEC Control, FECCR, R/W, Address = 93h, Default = 00h

Bit	Name	Description
<7:2>	rs	Reserved. Must be set to '0' when written.
1	fecht	0 = FEC operation is on 1 = FEC operation halted
0	fecbp	0 = FEC encoder and decoder included in the data path. 1 = FEC encoder and decoder are bypassed.

5.4.4 Registers 94h through 9Fh are Reserved

5.5 Framers Transmit Registers

Table 39. Framers Payload Rate, PLRATE, R/W, Address = A0h, Default = 18h

Bit	Name	Description
7	rs	Reserved. Must be set to '0' when written.
6	rs	Set to '0' for normal operation.
<5:0>	rs	Set to 18h for normal operation.

Table 40. Reference Transmit Water Level, HTFWL, R/W, Address = A1h, Default = 2Eh

Bit	Name	Description
<7:0>	htfwl	Water Level for Transmit FIFO. The water level has direction. The FIFO depth is 80 bits. The write pointer should be ahead of the read pointer by 40 bits. If the FIFO is loaded above the water level, no stuff bits are inserted. If the FIFO is loaded below the water level, four stuff bits are inserted.

Table 41. Actual Transmit Water Level, TFWL, R, Address = A2h

Bit	Name	Description
<7:0>	htfwl	Actual water level for transmit FIFO. Granularity determined by htfwl_res in HTFCR register

Table 42. Transmit Control Register, HTFCR, R/W, Address = A3h, Default = 08h

Bit	Name	Description
7	rs	Reserved. Must be set to '0' when written.
6	htfwl_res	1 = 0.25 UI granularity of the TFLW register 0 = 0.50 UI granularity of the TFLW register
5	h_fif_rst	Set this bit to '1' and then '0' to reset the transmit FIFO pointers at initialization or whenever the HTFWL register has been reprogrammed.
4	h_frm_rst	Set this bit to '1' and then '0' to reset the transmit frame counter at initialization.
3	ds1sync_dis	1 = disable synchronization of the HDSL2 transmit frame alignment to the T1 frame alignment using TFSYNC. This configuration is recommended for HDSL2 T1 transport. 0 = force synchronization of the HDSL2 transmit frame alignment to the T1 frame alignment using TFSYNC. This configuration allows the receive T1 frame position to be recovered from the HDSL2 receive frame sync but will require HDSL2 receive framer resynchronization every time the T1 frame alignment shifts.
2	dis_frslip	Set this bit to '1' to reset the FIFO overflow/underflow alarm bits in the HRFDR register, clear the pending interrupt, and disable future FIFO interrupts. Set this bit to '0' to enable FIFO interrupts.
1	disempt	Set this bit to '1' to reset the dlempy bit in the HRFSR register, clear the pending interrupt, and disable future 6 ms transmit frame interrupts. Set this bit to '0' to enable 6 ms transmit frame interrupts.
0	syncstuff	1 = disable automatic stuffing bit insertion and force stuffing bit insertion every other frame. 0 = enable automatic stuffing bit insertion based upon the transmit FIFO water level.

Table 43. Transmit Test Control Register, HTFTCR, R/W, Address = A4h, Default = 00h

Bit	Name	Description
<7:3>	rs	Reserved. Must be set to '0' when written.

Table 43. Transmit Test Control Register, HTFTCR, R/W, Address = A4h, Default = 00h

Bit	Name	Description
2	disw_d	1 = disable writes to the transmit FIFO. The FIFO contents will be retransmitted every 80 bits. 0 = enable writes to the transmit FIFO for normal operation.
1	crc_er	Set this bit to '1' to force transmission of a corrupt CRC in one frame. This bit is automatically cleared.
0	fsw_er	Set this bit to '1' to force transmission of a corrupt frame sync word (FSW) in one frame. This bit is automatically cleared.

Table 44. Transmit Data Byte Selection Register, HTFBSR, R/W, Address = A5h, Default = 00

Bit	Name	Description
<7:6>	rs	Reserved. Must be set to '0' when written.
<5:0>	htfbsr	Timeslot monitor select register. This register selects a pair of T1 payload timeslot to be monitored using the HTFRSRH and HTFRSRL registers. This feature provides a mechanism to monitor outgoing transmit data which may be used for detecting T1 in-band loopback codes. The processor must wait one frame time after updating [htfbsr] before reading the HTFRSR and HTFRSRL registers.

Table 45. Data Read Sample (High) Register, HTFRSRH, R, Address = A6h

Bit	Name	Description
<7:0>	htfrsrh	Data read sample register. Enables the μ P to read data from specific channels. Contains the data byte in the time slot specified in the HTFBSR register. Contents are updated when [htfbsr] is updated.

Table 46. Data Read Sample (Low) Register, HTFRSRL, R, Address = A7h

Bit	Name	Description
<7:0>	htfrsrl	Data read sample register. Enables the μ P to read data from specific channels. Contains the data byte following the time slot specified in the HTFBSR register. Contents are updated when [htfbsr] is updated.

Table 47. Transmit Frame Control Register, HTFTMR, R/W, Address = A8h, Default = 00h

Bit	Name	Description
7	tser_nml	0 = send all 1's or all 0's over the HDSL2 overhead channel. All 1's is selected when send_state=1, and all 0's is selected when send_state=0. See Table 48 . 1 = send normal HDSL2 overhead data.
6	descram_lt	1 = select H2TU-R to H2TU-C descrambler polynomial. 0 = select H2TU-C to H2TU-R descrambler polynomial.
5	descram_en	1 = enable the descrambler. 0 = disable the descrambler.

Table 47. Transmit Frame Control Register, HTFTMR, R/W, Address = A8h, Default = 00h

Bit	Name	Description
4	scram_nt	1 = select H2TU-R to H2TU-C scrambler polynomial. 0 = select H2TU-C to H2TU-R scrambler polynomial.
3	scram_en	1 = enable the scrambler. 0 = disable the scrambler.
2	frame_inh	1 = send all 1's or all 0's frame sync word. See Table 48 . 0 = transmit normal frame sync word.
1	send_state	This bit selects between all 1's or all 0's patterns for insertion into the payload and HDSL2 overhead channel in conjunction with the send_nml and tser_nml bits. See Table 48 . 1 = all 1's is selected. 0 = all 0's is selected.
0	send_nml	1 = send all 1's on the HDSL2 payload when send_state=1. Send all 0's on the HDSL2 payload when send_state=0. 0 = send normal HDSL2 payload data, overhead data and frame sync word. See Table 48 .

Table 48. All 1's / 0's Control

send_nml	frame_inh	tser_nml	Frame Sync Word and Stuff Bits	Other HDSL2 Overhead	Data Payload
0	don't care	don't care	normal	normal	normal
1	0	1	normal	normal	SEND_STATE
1	0	0	normal	SEND_STATE	SEND_STATE
1	1	don't care	SEND_STATE	SEND_STATE	SEND_STATE

Table 49. Transmit Sync Word (First 8 bits), HTFFSW1, R/W, Address = A9h, Default = 00h

Bit	Name	Description
<7:0>	htfsw1	First 8 bits of the Frame Sync Word (FSW). Bit 7 is the first bit of the FSW

Table 50. Transmit Sync Word (Last 2 bits), HTFFSW2, R/W, Address = AAh, Default = 00h

Bit	Name	Description
<7:2>	rs	Reserved. Must be set to 0 when written.
<1:0>	htfsw2	Last 2 bits of the Frame Sync Word (FSW). Bit 0 is the last bit of the FSW

5.5.1 Registers ABh through B0h are Reserved

Table 51. HDSL2 Transmit Overhead Register 1, HTFH0H1, R/W, Address = B1h, Default = 00h

Bit	Name	Description
7	eoc10	Transmit eoc bit 10
6	eoc8	Transmit eoc bit 8
5	eoc7	Transmit eoc bit 7
4	eoc6	Transmit eoc bit 6
3	eoc5	Transmit eoc bit 5
2	eoc4	Transmit eoc bit 4
1	eoc3	Transmit eoc bit 3
0	eoc2	Transmit eoc bit 2

Table 52. HDSL2 Transmit Overhead Register 2, HTFH0H2, R/W, Address=B2h, Default=00h

Bit	Name	Description
7	eoc19	Transmit eoc bit 19
6	eoc18	Transmit eoc bit 18
5	eoc16	Transmit eoc bit 16
4	eoc15	Transmit eoc bit 15
3	eoc14	Transmit eoc bit 14
2	eoc13	Transmit eoc bit 13
1	eoc12	Transmit eoc bit 12
0	eoc11	Transmit eoc bit 11

Table 53. HDSL2 Transmit Overhead Register 3, HTFH0H3, R/W, Address = B3h, Default = 00h

Bit	Name	Description
7	uib	Transmit unspecified indicator bit
6	eoc1	Transmit eoc bit 1
5	losd	Transmit loss of signal defect bit
4	eoc24	Transmit eoc bit 24
3	eoc23	Transmit eoc bit 23
2	eoc22	Transmit eoc bit 22
1	eoc21	Transmit eoc bit 21
0	eoc20	Transmit eoc bit 20

Table 54. HDSL2 Transmit Overhead Register 4, HTFH0H4, R/W, Address = B4h, Default = 00h

Bit	Name	Description
7	eoc17	Transmit eoc bit 17
6	segd	Transmit segment defect bit
5	eoc9	Transmit eoc bit 9
4	sega	Transmit segment anomaly bit
3	sb1	Transmit stuff bit 1
2	sb2	Transmit stuff bit 2
1	sb3	Transmit stuff bit 3
0	sb4	Transmit stuff bit 4

5.6 Framers Receive Registers

Table 55. Receive Control Register, HRFCR, R/W, Address = C0h, Default 00h

Bit	Name	Description
7	rs	Reserved. Must be set to '0' when written.
6	up_syncdis	1 = enable automatic frame sync loss detection. 0 = frame sync loss detection performed in software.
5	ercnt_rst	1 = reset CRC error counter (HRFCRC).
4	detrst	1 = reset the detflg in the HRFSR register
3	dettype	This bit selects whether a 64-bit all 1's or all 0's pattern is detected by detflg, HRFSR bit 6. 1 = detect all 1's. 0 = detect all 0's.
2	stuff_qual	1 = qualify the four stuff bits in the frame sync word detection algorithm. 0 = do not qualify the four stuff bits in the frame sync word detection algorithm.
1	syncrst	Set this bit to '1' then back to '0' to force the framer to reacquire receive frame alignment.
0	crdet	This bit should be set to '1' to reset the fsevent and fsdet bits in the HRFSR register, clear the pending interrupt and prevent future 6ms receive frame interrupts. This bit should be set to '0' again to enable the 6ms receive frame interrupt.

Table 56. Receive Test Control Register, HRFTCR, R/W, Address = C1h, Default = 00h

Bit	Name	Description
<7:3>	rs	Reserved. Must be set to '0' when written.
2	dis_cnt	1 = disable the DS1 counter for 8 RCLK cycles. Not latched. 0 = enable the DS1 counter for normal operation.
1	diswr_m	1 = disable writes to the receive FIFO. 0 = enable writes to the receive FIFO for normal operation.
0	rs	Reserved. Must be set to '0' when written.

5.6.1 Receive FIFO Water Level

The receive FIFO water level is defined as the difference between the write and read pointers. The value in HRFWL and its rate of change provide an indication of the difference between the actual receive payload data rate and the rate data clocked out of the device using RCLK. The RCLK frequency is adjusted to match the receive payload data rate by reading the FIFO water level at every 6 ms receive frame interrupt. With this information, the RCLK frequency is then adjusted to maintain the FIFO near the ideal water level.

Table 57. Receive FIFO Water Level Register, HRFWL, R, Address = C2h

Bit	Name	Description
<7:0>	hrfwl	Receive channel FIFO water level. The value in this register ranges between 0 to 120 and the receive FIFO is 60 bits deep. A register value of 60 corresponds to a FIFO water level of 30 bits which is the optimum average water level.

Table 58. FIFO Depth Register, HRFFDR, R, Address = C3h

Bit	Name	Description
7	sbid1	Stuff indicator bit 1. This bit is updated every 6 ms receive frame interrupt. 1 = long frame 0 = short frame
6	sbid2	Stuff indicator bit 2. This bit is updated every 6 ms receive frame interrupt. 1 = long frame 0 = short frame
5	misaligned_rx	This bit is set to '1' when receive FIFO data is misaligned or has a parity error.
4	misaligned_tx	This bit is set to '1' when transmit FIFO data is misaligned or has a parity error.
3	underflow_rx	This bit is set to '1' when there is a receive FIFO underflow.
2	overflow_rx	This bit is set to '1' when there is a receive FIFO overflow.
1	underflow_tx	This bit is set to '1' when there is a transmit FIFO underflow.
0	overflow_tx	This bit is set to '1' when there is a transmit FIFO overflow.

Table 59. Receive Status Register, HRFSR Register, R, Address = C4h

Bit	Name	Description
7	rs	Reserved.
6	detflg	This bit is set to '1' when the last 64 bits meet the criteria set up by the "dettype" bit in the HRFCR register.
5	rs	Reserved.
4	crcerr	This bit is set to '0' when a CRC error has been detected.
3	fcsync	This bit is set to '1' when the receive framer establishes frame synchronization. Frame sync is declared automatically after detection of two frames with correct frame sync and stuff id bits (and stuff bits when HRFCR bit 2 is set to '1'). When HRFCR bit 6 is set to '1', fcsync will be automatically set to '0' upon loss of frame synchronization after receiving 5 consecutive frames with framing bit errors. When HRFCR bit 6 is set to '0', the processor must detect frames with framing bit errors and force the framer to reacquire frame alignment.
2	fsdet	This bit is set to '1' when all framing bits in the current frame are correct and should be read during the 6 ms receive frame interrupt service routine (indicated by fsevent=1).
1	fsevent	This bit transitions from '0' to '1' to indicate a 6ms receive frame sync interrupt. When this interrupt occurs, fsdet is updated to indicate whether there are framing bit errors in the current frame. The fsevent bit and the pending interrupt are cleared when HRFCR bit 0 is set to '1'.
0	dlempty	This bit transitions from '0' to '1' to indicate a 6ms transmit frame interrupt. When this interrupt occurs, the transmit overhead registers should be loaded with new data. The dlempty bit and the pending interrupt are cleared when HTFCR bit 1 is set to '1'.

Table 60. Receive Timing & Loopback Register, HRFTTCR, R/W, Address = C5h, Default = 00h

Bit	Name	Description
<7:6>	rs	Reserved. Must be set to '0' when written.
5	bpfrm	1 = bypass the framer/mapper. 0 = enable the framer/mapper.
4	hloop	1 = loop the framer/mapper output back to the framer/mapper input. 0 = disable the framer/mapper loopback for normal operation.
3	rlb	1 = enable remote loopback (RSER to TSER, RFSYNC to TFSYNC, and RCLK to TCLK) 0 = disable the remote loopback for normal operation.
2	llb_clk	1 = enable the clock local loopback (TCLK to RCLK) 0 = disable the clock local loopback for normal operation.
1	llb	1 = enable the data local loopback (TSER to RSER and TFSYNC to RFSYNC) 0 = disable the data local loopback for normal operation.
0	tclk_disbl	1 = disable the RCLK output. 0 = enable the RCLK output for normal operation.

5.6.2 PLL Synthesizer Registers

The Transceiver/Framer has an internal digital phase lock loop (DPLL) synthesizer that generates a receive clock at the payload data rate. [Figure 22 on page 66](#) shows a block diagram of the PLL circuit. Three variables are necessary to set the PLL to the required line rate. "α" is the phase

adjustment variable and is set in the associated HRFP AJ (CAh) register. “ β ” is the NCO clock division ratio variable and is set in the HRFPAC (CBh) register. CW is a 16 bit control word that is set in the HRFNCR1 (C6h) and HRFNCR2 (C7h) registers.

Table 61. NCO Control Register (MSB), HRFNCR1, R/W, Address = C6h, Default = 17h

Bit	Name	Description
<7:0>	hrfnrc1[7:0]	NCO control register MSBs. High byte of 16 bit signed value; transferred to the NCO accumulator when high byte is written. Set to 17h for normal operation.

Table 62. NCO Control Register (LSB), HRFNCR2, R/W, Address = C7h, Default = 5Ah

Bit	Name	Description
<7:0>	hrfnrc2[7:0]	NCO control register LSBs. Low byte of 16 bit signed value; transferred to the NCO accumulator when high byte is written. Set to 5Ah for normal operation.

Table 63. DPLL Phase Adjustment Register, HRFP AJ, R/W, Address = CAh, Default = 2Ch

Bit	Name	Description
<7:6>	rs	Reserved. Must be set to '0' when written.
<5:0>	hrfpaj	Phase adjustment parameters. This register holds values for α up to 63. Set to 2Ch for normal operation.

Table 64. DPLL Clock Division Ratio, HRFPAC, R/W, Address = CBh, Default = 15h

Bit	Name	Description
<7:6>	rs	Reserved. Must be set to '0' when written.
<5:0>	beta	NCO clock division ratio, β . Set to 15h for normal operation.

Figure 22. RCLK Generation Circuit

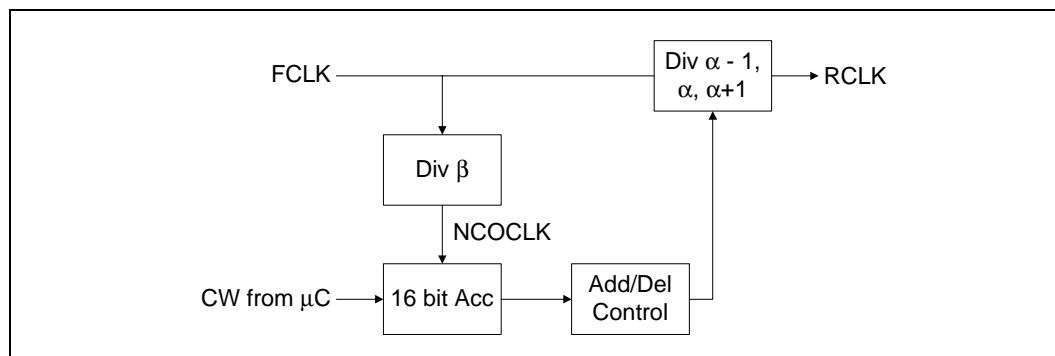

Table 65. CRC Counter Register, HRFRCR, R, Address = C9h

Bit	Name	Description
<7:0>	hrfrcr	CRC error counter. The counter saturates at FFh and is reset with ercnt_rst in HRFRCR.

5.6.3 Registers CCh through D1h are Reserved

Table 66. HDSL2 Receive Overhead Register 1, HRFHOH1, R, Address = D2h

Bit	Name	Description
7	eoc10	Receive eoc bit 10
6	eoc8	Receive eoc bit 8
5	eoc7	Receive eoc bit 7
4	eoc6	Receive eoc bit 6
3	eoc5	Receive eoc bit 5
2	eoc4	Receive eoc bit 4
1	eoc3	Receive eoc bit 3
0	eoc2	Receive eoc bit 2

Table 67. HDSL2 Receive Overhead Register 2, HRFHOH2, R, Address = D3h

Bit	Name	Description
7	eoc19	Receive eoc bit 19
6	eoc18	Receive eoc bit 18
5	eoc16	Receive eoc bit 16
4	eoc15	Receive eoc bit 15
3	eoc14	Receive eoc bit 14
2	eoc13	Receive eoc bit 13
1	eoc12	Receive eoc bit 12
0	eoc11	Receive eoc bit 11

Table 68. HDSL2 Receive Overhead Register 3, HRFHOH3, R, Address = D4h

Bit	Name	Description
7	uib	Receive unspecified indicator bit
6	eoc1	Receive eoc bit 1
5	losd	Receive loss of signal defect bit
4	eoc24	Receive eoc bit 24
3	eoc23	Receive eoc bit 23

Table 68. HDSL2 Receive Overhead Register 3, HRFHOH3, R, Address = D4h

Bit	Name	Description
2	eoc22	Receive eoc bit 22
1	eoc21	Receive eoc bit 21
0	eoc20	Receive eoc bit 20

Table 69. HDSL2 Receive Overhead Register 4, HRFHOH4, R, Address = D5h

Bit	Name	Description
7	eoc17	Receive eoc bit 17
6	segd	Receive segment defect bit
5	eoc9	Receive eoc bit 9
4	sega	Receive segment anomaly bit
3	sb1	Receive stuff bit 1
2	sb2	Receive stuff bit 2
1	sb3	Receive stuff bit 3
0	sb4	Receive stuff bit 4

5.6.4 Registers D6h through DCh are Reserved

Table 70. Receive Frame Sync Word (First 8 bits), HRFFSW1, R/W, Address = DDh, Default = 00h

Bit	Name	Description
<7:0>	HRFFSW1 7:0	First 8 bits of the receive frame sync word. Bit 7 is the first bit of the FSW.

Table 71. Receive Frame Sync Word & Stuff Bits, HRFFSWB, R/W, Address = DEh, Default = 00h

Bit	Name	Description
<7:6>	rs	Reserved
<5:2>	HRFSB 3:0	Receive stuff bits. Bit 3 is the first stuff bit.
<1:0>	HRFFSW2 1:0	Last 2 bits of the receive frame sync word. Bit 0 is the last bit of the FSW.

5.6.5 Registers DF through FF are Reserved

6.0 Analog Front End Test Specifications

Note: Table 72 through Table 77 and, Figure 5 and Figure 23 and represent the performance specifications of the SK70740 AFE and are guaranteed by test except, where noted, by design. The minimum and maximum values listed in Table 74 through Table 77 are guaranteed over the recommended operating conditions specified in Table 73.

Table 72. Absolute Maximum Ratings

Parameter	Symbol	Min	Max	Units
Supply voltage ¹ (reference to ground ^{2, 3})	RVCC1, RVCC2, RVCC3, RVCC4, TVCC1, TVCC2, TVCC3, TVCC4, BVCC, AVCC1, AVCC2, RDVCC, TDVCC	-0.3	+6.0	V
	DVCC, IOVCC1, IOVCC2	-0.3	+4.0	V
Input voltage ^{2, 3} , any digital input pin	–	-0.3	+5.5	V
Continuous output current, any output pin	–	–	±25	mA
Storage temperature	T _{STOR}	-65	+150	°C
Caution: Exceeding these values may cause permanent damage. Functional operation under these conditions is not implied. Exposure to maximum rating conditions for extended periods may affect device reliability.				
1. The maximum potential between any VCC pin must never exceed 0.3 V. 2. All GND pins must be kept at 0 V. 3. Differential voltage between any ground pins must be < 0.3 V.				

Table 73. Recommended Operating Conditions

Parameter	Symbol	Min	Typ ³	Max	Units
Supply voltage ¹	RVCC1, RVCC2, RVCC3, RVCC4, TVCC1, TVCC2, TVCC3, TVCC4, BVCC, AVCC1, AVCC2, RDVCC, TDVCC	4.75	5.0	5.25	V
	DVCC, IOVCC1, IOVCC2 ¹	3.14	3.3	3.46	V
Supply ground ²	RGND1, RGND2, RGND3, RGND4, TGND1, TGND2, TGND3, TGND4, BGND, AGND1, AGND2, RDGND, TDGND, IOGND1, IOGND2, DGND	-0.25	-	0.3	V
Ambient operating temperature	T _A	-40		+85	°C
1. The maximum potential between any VCC pin must never exceed 0.3 V. 2. Differential voltage between any ground pins must be < 0.3 V. For design aid only; not guaranteed and not subject to production testing. 3. Typical values are at 25° C and are for design aid only; not guaranteed and not subject to production testing.					

Table 74. DC Electrical Characteristics

Parameter	Symbol	Min	Typ ¹	Max	Units	Test Conditions
Supply current, 5 V supplies ²	ICC5	-	98	106	mA	Full operation @ 21.5 MHz
Supply current, 3.3 V supplies ^{2,3}	ICC3	-	11.5	12.5	mA	DVCC and IOVCC
Full power consumption	P _{wr}	-	525	600	mW	

Table 74. DC Electrical Characteristics (Continued)

Parameter	Symbol	Min	Typ ¹	Max	Units	Test Conditions
Digital input Low voltage	Vil	-	-	0.8	V	
Digital input High voltage	Vih	2.0	-	-	V	
Digital output Low voltage	Vol	-	-	0.4	V	IOUT= 1.6 mA
Digital output High voltage	Voh	2.4	-	-	V	IOUT= 400 μ A
Transmitter bias voltage (TTIP/TRING)	Vcmt	2.2	2.5	2.8	V	
Receive bias voltage (RTIP/RRING)	Vcmr	2.2	2.5	2.8	V	
1. Typical values are at 25° C and are for design aid only; not guaranteed and not subject to production testing. 2. Full operation at 21.5 MHz crystal frequency. 3. I/O power consumption measured with 30 pF load.						

Table 75. Transmitter Electrical Parameters

Parameters	Sym	Min	Typ	Max	Unit	Test Conditions
Transmitter peak voltage TTIP, TRING	Vppd	-	2.6	-	Vp-p (diff)	500 Ω load single-ended or 1 k Ω differential
Upstream small signal bandwidth	f _{3dB}	325	342	360	kHz	
Downstream small signal bandwidth	f _{3dB}	490	518	545	kHz	

Table 76. Receiver Electrical Parameters

Parameters	Sym	Min	Typ	Max	Unit	Test Conditions
Input voltage range RTIP, RRING	Vi	-	2.0	10	Vp-p (diff)	
Programmable AGC gain	Av	-18	-	+3	dB	

Table 77. AFE Interface Timing Specifications (see Figure 23)

Parameter	Symbol	Min ²	Typ ¹	Max ²	Unit	Test Conditions
REFCLK frequency (21.500 MHz crystal)	-	-	10.75	-	MHz	
REFCLK duty cycle	-	45	-	55	%	
Clock oscillator input (XTALI) Low voltage ⁴	Vil	-	-	0.8	V	
Clock oscillator input (XTALI) High voltage ⁴	Vih	2.0	-	-	V	
1. Typical values are at 25° C and are for design aid only; not guaranteed and not subject to production testing. 2. Measured with 30pF loads on all outputs. 3. Not subjected to production testing. For design aid only. 4. If XTALI pin is overdriven by a clock signal, then XTALO pin must be grounded. XTALI pin may be driven by a 3.3 V or 5.0 V clock oscillator regardless of the supply voltage applied at IOVCC1 and IOVCC2.						

Table 77. AFE Interface Timing Specifications (see Figure 23)

Parameter	Symbol	Min ²	Typ ¹	Max ²	Unit	Test Conditions
DAC<3:0>, RSDO and \overline{ACE} setup time	Tts	30	65	-	ns	Typical values are based on typical data that Transceiver can provide.
DAC<3:0>, RSDO and \overline{ACE} hold time	Tth	0	15	-	ns	
REFCLK to ADC<5:0> valid data ³	Tvd	-	5	20	ns	
REFCLK to RSDI valid data	Tvdi	-	5	15	ns	

1. Typical values are at 25° C and are for design aid only; not guaranteed and not subject to production testing.
 2. Measured with 30pF loads on all outputs.
 3. Not subjected to production testing. For design aid only.
 4. If XTALI pin is overdriven by a clock signal, then XTALO pin must be grounded. XTALI pin may be driven by a 3.3 V or 5.0 V clock oscillator regardless of the supply voltage applied at IOVCC1 and IOVCC2.

Figure 23. AFE Interface Timing

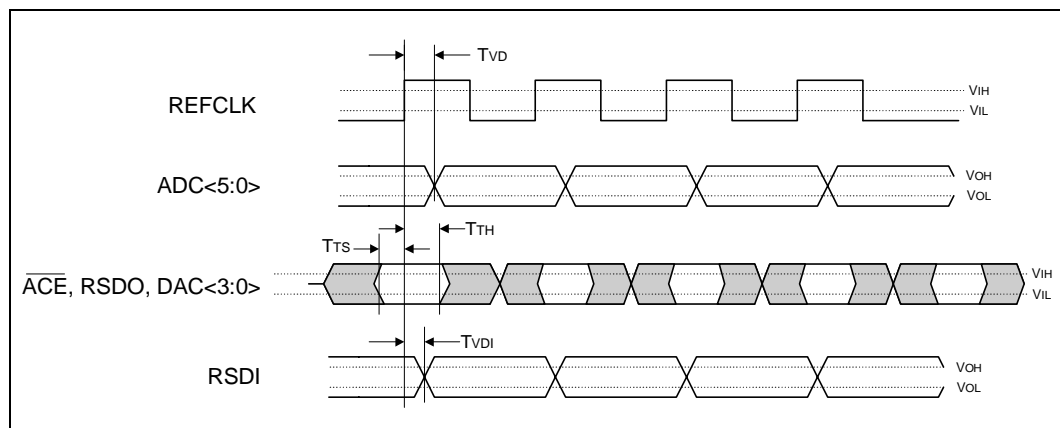

7.0 Transceiver/Framer Test Specifications

Note: Table 78 through Table 84 and Figure 24 through Figure 27 represent the performance specifications of the SK70744 Transceiver/Framer and are guaranteed by test except, where noted, by design. The minimum and maximum values listed in Table 80 through Table 84 are guaranteed over the recommended operating conditions specified in Table 79.

Table 78. Absolute Maximum Ratings

Parameter	Symbol	Min	Max	Unit
Digital Supply voltage ¹ (reference to ground ²)	VCC1, VCC2, VCC3, VCC4, VCCPLL	-0.3	+4.0	V
I/O Supply voltage ¹ (reference to ground ²)	IOVCC1, IOVCC2, IOVCC3, IOVCC4	-0.3	+4.0	V
Input voltage ² , any input pin	–	-0.3	+5.5	V
Continuous output current, any output pin	–	–	±25	mA
Storage temperature	T _{STOR}	-65	+150	°C
Caution: Exceeding these values may cause permanent damage. Functional operation under these conditions is not implied. Exposure to maximum rating conditions for extended periods may affect device reliability.				
1. The maximum potential between any VCC must never exceed ±1.2 V. 2. GND4 = 0V, GND3 = 0V; GND2 = 0V; GND1 = 0V.				

Table 79. Recommended Operating Conditions

Parameter	Symbol	Min	Typ ³	Max	Unit
Supply voltage ¹	IOVCC1, IOVCC2, IOVCC3, IOVCC4	3.14	3.30	3.46	V
	VCC1, VCC2, VCC3, VCC4 VCCPLL	2.38	2.50	2.63	V
Supply ground ²	GND1, GND2, GND3, GND4 GNDPLL IOGND1, IOGND2, IOGND3, IOGND4	-0.25	-	+0.3	V
Ambient operating temperature	T _A	-40	-	+85	°C
1. The maximum potential between any VCC pin must never exceed 0.3 V. 2. Differential voltage between any ground pins must be < 0.3 V. For design aid only; not guaranteed and not subject to production testing. 3. Typical values are at 25° C and are for design aid only; not guaranteed and not subject to production testing.					

Table 80. DC Electrical Characteristics

Parameter	Sym	Min	Typ ¹	Max	Unit	Test Conditions
Supply current (2.5 V supply)	I _{CC2}	–	320	400	mA	
Supply current (3.3 V supply)	I _{CC3}		45	55	mA	
Input Low voltage	V _{IL}	–	–	0.8	V	
1. Typical values are at 25° C and are for design aid only; not guaranteed and not subject to production testing. 2. Applies to I/O pins when configured as inputs. 3. Applies to tristated pins. 4. Does not include current through internal or external pull up/down resistance.						

Table 80. DC Electrical Characteristics (Continued)

Parameter	Sym	Min	Typ ¹	Max	Unit	Test Conditions
Input High voltage	V _{IH}	2.0	–	–	V	
Output Low voltage	V _{OL}	–	–	0.4	V	I _{OUT} =1.6 mA
Output High voltage	V _{OH}	2.4	–	–	V	I _{OUT} =400 μA
Input leakage current ^{2, 4}	I _{IL}	–	–	±50	μA	0 < V _{IN} < V _{CC2}
Tristate leakage current ^{3, 4}	I _{TOL}	–	–	±30	μA	0 < V < V _{CC2}
Input capacitance (individual pins)	C _{IN}	–	12	–	pF	
Load capacitance DAC<3:0>	CLREF	–	–	15	pF	

1. Typical values are at 25° C and are for design aid only; not guaranteed and not subject to production testing.
 2. Applies to I/O pins when configured as inputs.
 3. Applies to tristated pins.
 4. Does not include current through internal or external pull up/down resistance.

Table 81. AFE Data Interface Timing Specifications (see Figure 24)

Parameter	Symbol	Min	Typ ¹	Max	Unit
REFCLK frequency (21.5 MHz Crystal)	–	–	10.750	–	MHz
REFCLK duty cycle	–	45	–	55	%
ADC<5:0> to rising edge of REFCLK	T _{DS}	60	–	–	ns
REFCLK rising edge to ADC<5:0> hold time	T _{DH}	0	–	–	ns
DAC<3:0> delay from rising edge of REFCLK	T _{AD}	–	–	40	ns

1. Typical values are at 25° C and are for design aid only; not guaranteed and not subject to production testing.
 2. Measured with 15 pF load.

Figure 24. AFE Data Interface Relative Timing

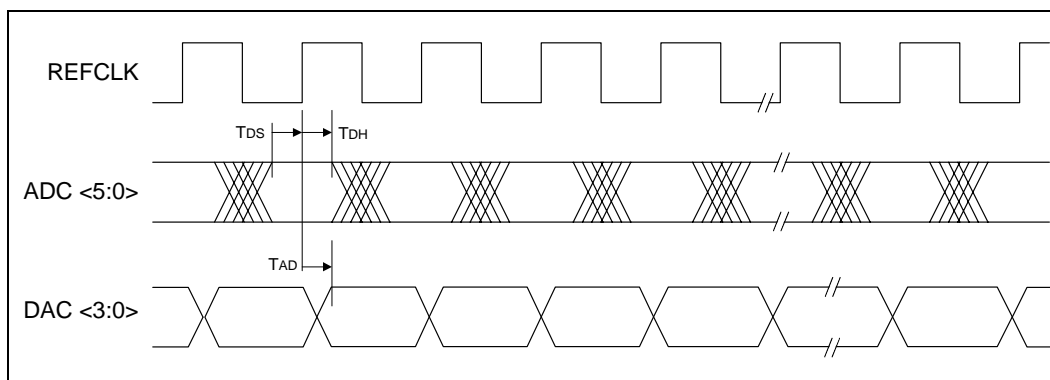

Table 82. AFE Control Interface Timing Specifications (see Figure 5 and Figure 25)

Parameter	Symbol	Min	Typ ¹	Max	Unit
RSDI setup time to REFCLK rising edge	T _{ss}	45	–	–	ns
REFCLK rising edge to RSDI hold time	T _{sh}	5	–	–	ns
RSDO delay from REFCLK rising edge	T _{sd}	–	–	35	ns
$\overline{\text{ACE}}$ falling edge delay from REFCLK rising edge	T _{ace}	–	–	40	ns

1. Typical values are at 25° C and are for design aid only; not guaranteed and not subject to production testing.
 2. Measured with 15 pF load.

Figure 25. AFE Control Interface Relative Timing

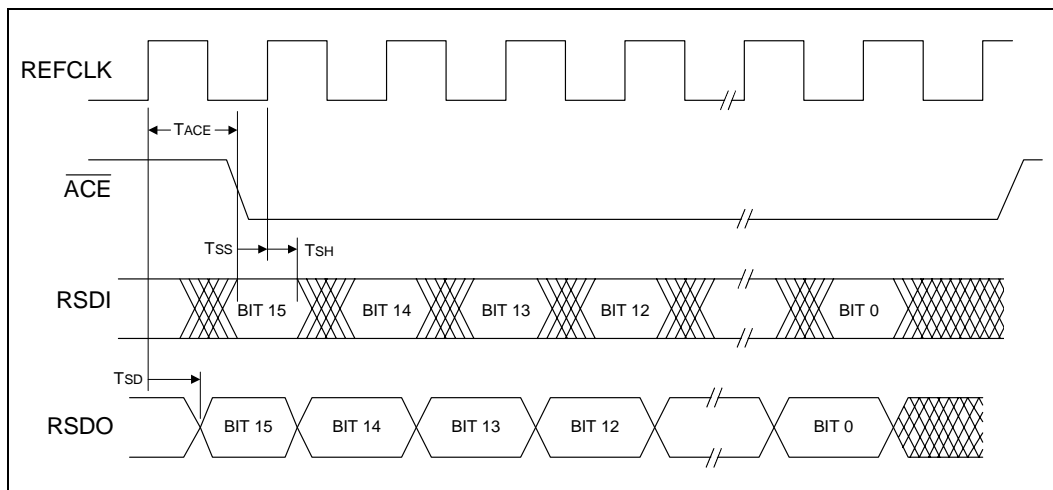

Table 83. TDM Interface Timing Specifications - T1 Transport Mode (see Figure 26)

Parameter	Symbol	Min	Typ ¹	Max	Unit
TCLK, RCLK frequency ²	–	1.5438	1.5440	1.5442	MHz
TCLK, RCLK duty cycle	–	40	–	60	%
TFSYNC pulse width	T _{FS}	–	1/f _{TCLK}	–	ns
RFSYNC pulse width	T _{FS}	–	1/f _{RCLK}	–	ns
TSER setup time to TCLK falling edge	T _{DS}	10	–	–	ns
TSER hold time from TCLK falling edge	T _{DH}	20	–	–	ns
RSER delay from RCLK rising edge	T _{RD}	–	–	15	ns

1. Typical values are at 25° C and are for design aid only; not guaranteed and not subject to production testing.
 2. Min. and Max values are for design aid only; not guaranteed and not subject to production testing.

Figure 26. TDM Interface Timing - T1 Transport Mode

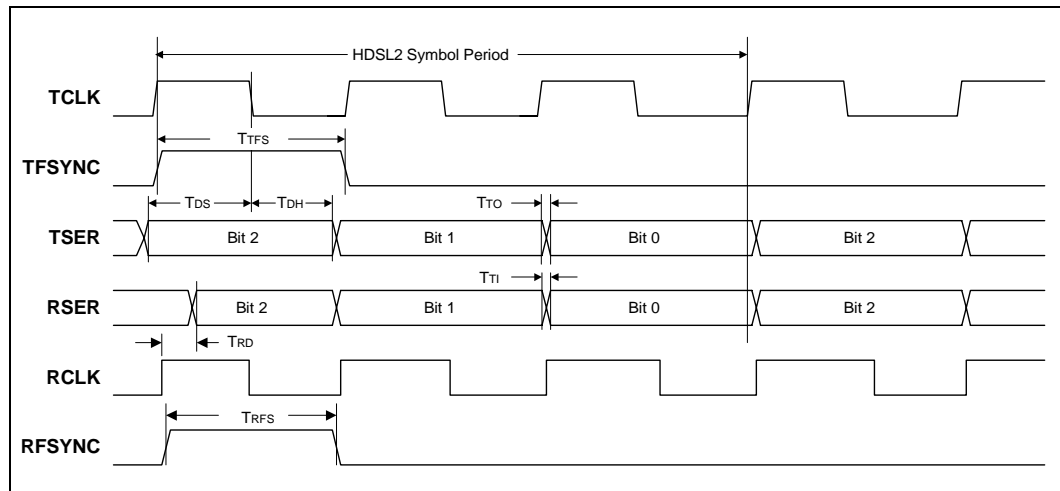

Table 84. Transceiver/Framer Reset Timing Specification

Parameter	Symbol	Min	Max	Unit	Test Conditions
RST Low pulse width	Trpwl	200	–	ns	

Table 85. Intel Bus Parallel I/O Timing Characteristics (see Figure 27)

Parameter	Sym	Min	Max	Unit	Test Conditions
ALE pulse width	Tale	10	–	ns	
Address valid to ALE falling edge setup time	Tas	10	–	ns	
ALE falling edge to address hold time	Tah	10	–	ns	
CS falling edge to RD falling edge	Tcsr	40	–	ns	
CS falling edge to WR falling edge	Tcsw	40	–	ns	
RD Low pulse width	Trw	80	–	ns	
RD falling edge to data valid	Trd	–	80	ns	
Data high impedance after RD rising edge	Trdz	–	40	ns	
WR Low pulse width	Tww	80	–	ns	
Write data setup time after WR falling edge	Tds	10	–	ns	
Read data hold time after RD rising edge	Trdh	0	–	ns	
Write data hold time after WR rising edge	Twdh	10	–	ns	
RD rising edge to ALE rising edge	Trdal	40	–	ns	

Table 86. Motorola Bus Parallel I/O Timing Characteristics (see Figure 27)

Parameter	Symbol	Min	Max	Unit	Test Conditions
\overline{DS} Low pulse width	TH	130	–	ns	
Read data valid time after \overline{DS} rising edge	TRDH	0	–	ns	
\overline{DS} rising edge to write data hold time	TWDH	5	–	ns	
Valid address to \overline{DS} falling edge	TAS	10	–	ns	
\overline{DS} falling edge to valid address hold time	Tah	10	–	ns	
Write data setup time after \overline{DS} falling edge	TDS	10	–	ns	
\overline{DS} falling edge to valid data	TRD	–	120	ns	
Data high impedance after \overline{CS} or \overline{DS} are asserted High	TRDZ	–	40	ns	
Required High time of \overline{DS}	TDSH	60	–	ns	

Figure 27. Parallel Microprocessor Bus Interface Timing

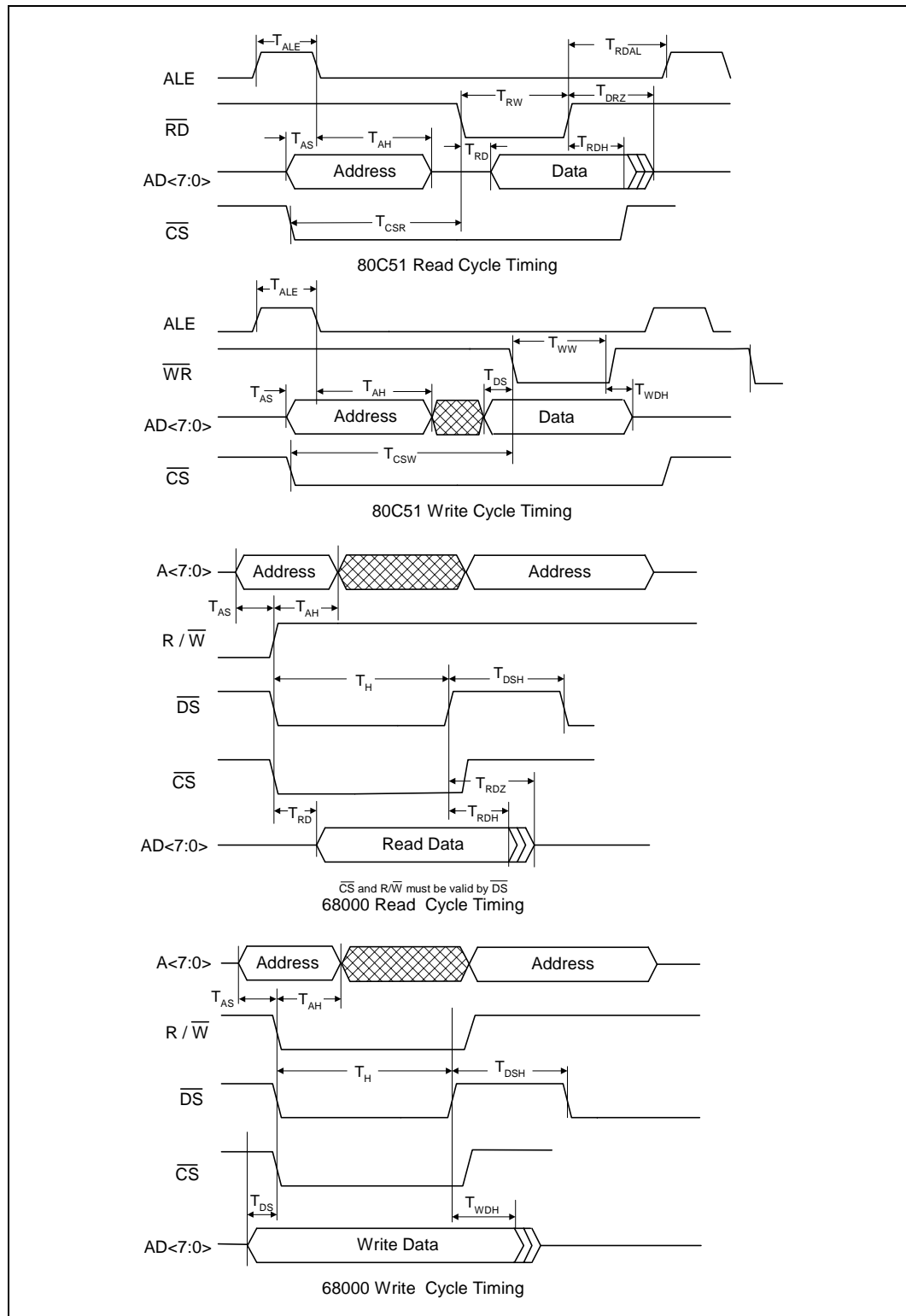

8.0 Mechanical Specifications

Figure 28. 64 Pin QFP Package

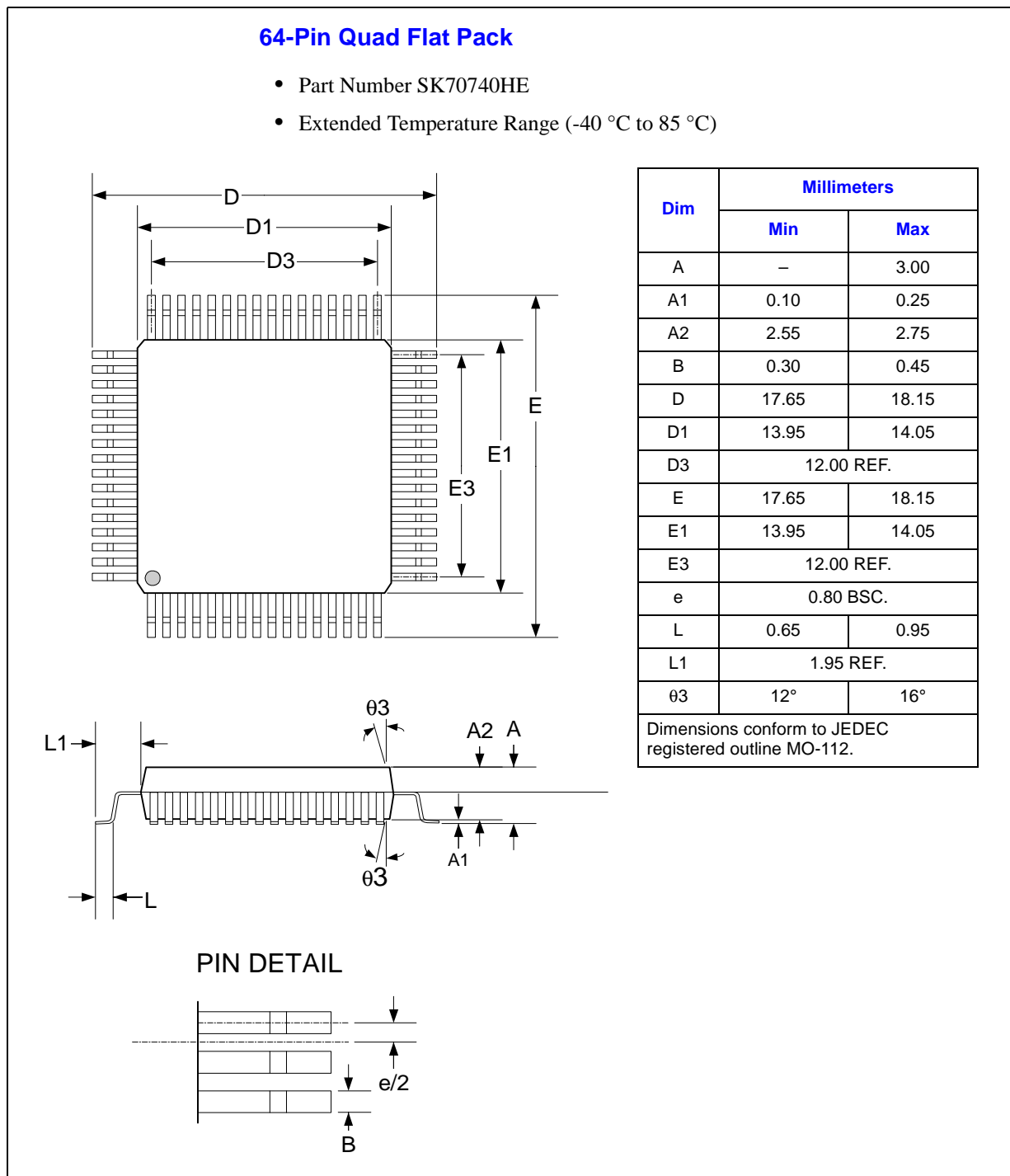
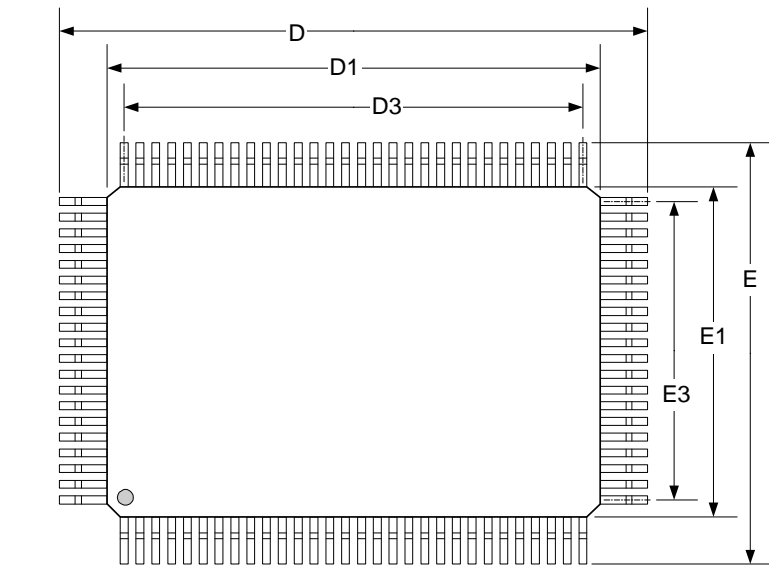

Figure 29. 100 Pin QFP Package

100 -Pin Quad Flat Pack

- Part Number SK70744HE
- Extended Temperature Range (-40 °C to 85 °C)



Dim	Millimeters	
	Min	Max
A	–	3.10
A1	0.10	0.36
A2	2.57	2.87
B	0.22	0.38
D	23.65	24.15
D1	19.90	20.10
D3	18.85 REF.	
E	17.65	18.15
E1	13.90	14.10
E3	12.35 REF.	
e	0.65 BSC.	
L	0.73	1.03
L1	1.95 REF.	
θ3	12°	16°

Dimensions conform to JEDEC registered outline MO-112.

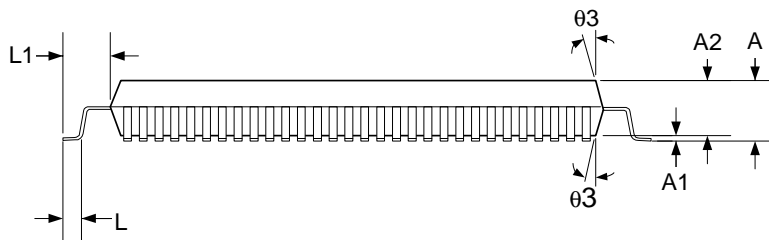

PIN DETAIL

