

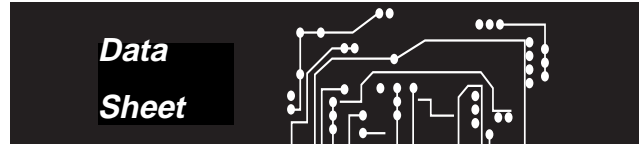

# PowerPC 403GC

## 32-Bit RISC

### Embedded Controller



#### Features

- PowerPC™ RISC CPU and instruction set architecture
- Glueless interfaces to DRAM, SRAM, ROM, and peripherals, including byte and half-word devices
- Separate instruction cache and write-back data cache, both two-way set-associative
- Memory management unit
  - 64-entry, fully associative TLB array
  - Variable page size (1KB-16MB)
  - Flexible TLB management
- Individually programmable on-chip controllers for:
  - Four DMA channels
  - DRAM, SRAM, and ROM banks
  - External interrupts
- Flexible interface to external bus masters
- Hardware multiplier and divider
- Thirty-two 32-bit general purpose registers

#### Applications

- Set-top boxes
- Consumer electronics and video games
- Telecommunications and networking
- Office automation (printers, copiers, fax)
- Personal digital assistants (PDA)

#### Specifications

- 25MHz, 33MHz, and 40MHz versions
- Interfaces to both 3V and 5V technologies
- Low-power 3.3V operation with built-in power management and stand-by mode
- Low-cost 160 lead PQFP package
- 0.5  $\mu\text{m}$  triple-level-metal CMOS

#### Overview

The PowerPC 403GC 32-bit RISC embedded controller offers high performance and functional integration with low power consumption. The 403GC RISC CPU executes at sustained speeds approaching one cycle per instruction. On-chip caches and integrated DRAM and SRAM control functions reduce chip count and design complexity in systems, while improving system throughput.

External I/O devices or SRAM/DRAM memory banks can be directly attached to the 403GC bus interface unit (BIU). Interfaces for up to eight memory banks and I/O devices, including a maximum of four DRAM banks, can be configured individually, allowing the BIU to manage devices or memory banks with differing control, timing, or bus width requirements.

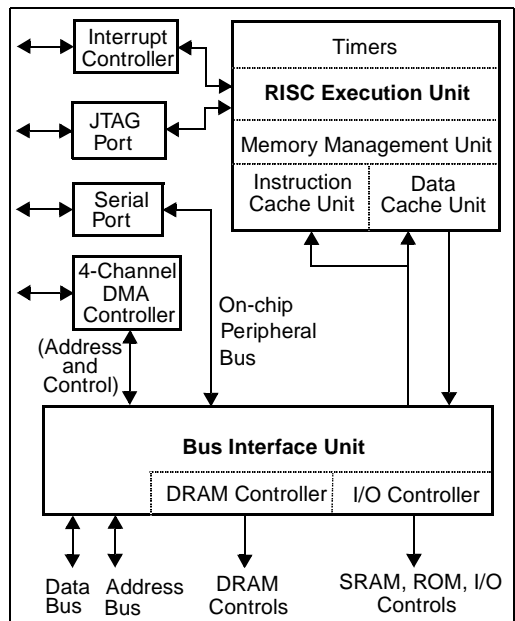

## IBM PowerPC 403GC

The 403GC RISC controller consists of a pipelined RISC processor core and several peripheral interface units: BIU, DMA controller, asynchronous interrupt controller, serial port, and JTAG debug port.

The RISC processor core includes the internal 2KB instruction cache and 1KB data cache, reducing overhead for data transfers to or from external memory. The instruction queue logic manages branch prediction, folding of branch and condition register logical instructions, and instruction prefetching to minimize pipeline stalls. The integrated memory management unit provides robust memory management and protection functions, optimized for embedded environments.

### RISC CPU

The RISC core comprises four tightly coupled functional units: the execution unit (EXU), the memory management unit (MMU), the data cache unit (DCU), and the instruction cache unit (ICU). Each cache unit consists of a data array, tag array, and control logic for cache management and addressing. The execution unit consists of general purpose registers (GPR), special purpose registers (SPR), ALU, multiplier, divider, barrel shifter, and the control logic required to manage data flow and instruction execution within the EXU.

The EXU handles instruction decoding and execution, queue management, branch prediction, and branch folding. The instruction cache unit passes instructions to the queue in the EXU or, in the event of a cache miss, requests a fetch from external memory through the bus interface unit. The MMU provides translation and memory protection for instruction and data accesses, using a unified 64-entry, fully associative TLB array.

### General Purpose Registers

Data transfers to and from the EXU are handled through the bank of 32 GPRs, each 32 bits wide. Load and store instructions move data operands between the GPRs and the data cache unit, except in the cases of noncacheable data or cache misses. In such cases the DCU passes the address for the data read or write to the BIU.

When noncacheable operands are being transferred, data can pass directly between the EXU and the BIU, which interfaces to the external memory being accessed.

### Special Purpose Registers

Special purpose registers are used to control debug facilities, timers, interrupts, the protection mechanism, memory cacheability, and other architected processor resources. SPRs are accessed using move to/from special purpose register (m<sub>tspr</sub>/m<sub>fspr</sub>) instructions, which move operands between GPRs and SPRs.

Supervisory programs can write the appropriate SPRs to configure the operating and interface modes of the execution unit. The condition register (CR) and machine state register (MSR) are written by internal control logic with program execution status and machine state, respectively. Status of external interrupts is maintained in the external interrupt status register (EXISR). Fixed-point arithmetic exception status is available from the exception register (XER).

### Device Control Registers

Device control registers (DCR) are used to manage I/O interfaces, DMA channels, SRAM and DRAM memory configurations and timing, and status/address information regarding bus errors. DCRs are accessed using move to/from device control register (m<sub>tdcr</sub>/m<sub>fdcr</sub>) instructions, which move operands between GPRs and DCRs.

### Instruction Set

Table 1 summarizes the 403GC instruction set by categories of operations. Most instructions execute in a single cycle, with the exceptions of load/store multiple, load/store string, multiply, and divide instructions.

### Bus Interface Unit

The bus interface unit integrates the functional controls for data transfers and address operations other than those which the DMA controller handles. DMA transfers use the address logic in the BIU to output the memory addresses being accessed.

Control functions for direct-connect I/O devices and for DRAM, SRAM, or ROM banks are provided by the BIU. Burst access for SRAM, ROM, and page-mode DRAM devices is supported for cache fill and flush operations.

The BIU controls the transfer of data between the external bus and the instruction cache, the data cache, or registers internal to the processor core. The BIU also arbitrates among external bus master and DMA transfers, the internal buses to the cache units and the register banks, and the serial port on the on-chip peripheral bus (OPB).

**Memory Addressing Regions**

The 403GC can address an effective range of four gigabytes, mapped to 3.5GB (256MB for SRAM/ROM or other I/O, 256MB DRAM, and 3GB OPB/reserved) of physical address space containing twenty-eight 128MB regions. Cacheability with respect to the instruction or data cache is programmed via the instruction and data cache control registers, respectively.

Within the DRAM and SRAM/ROM regions, a total of eight banks of devices are supported. Each bank can be configured for 8-, 16-, or 32-bit devices.

For individual DRAM banks, the number of wait states, bank size, RAS-to-CAS timing, use of an external address multiplexer (for external bus masters), and refresh rate are user-programmable. For each SRAM/ROM bank, the

bank size, bank location, number of wait states, and timings of chip selects, byte enables, and output enables are all user-programmable.

**Memory Management Unit**

The memory management unit (MMU) supports address translation and protection functions for embedded applications. When used with appropriate system level software, the MMU provides the following functions: translation of 4GB logical address space into physical addresses, independent enabling of instruction and data translation/protection, page level cacheability and access control via the translation mechanism, software control of page replacement strategy, and additional control over protection via zones.

The fully associative 64-entry TLB array handles both instruction and data accesses. The translation for any virtual address can be placed in any one of the 64 entries, allowing maximum flexibility by TLB management software. Each TLB entry contains a translation for a page that can be any one of eight sizes from 1KB to 16MB, incrementing by powers of 4.

The TLB can simultaneously contain any mix of page sizes. This feature enables the use of small pages when maximum granularity is required, reducing the amount of wasted memory when compared to the more common fixed 4KB page size.

Table 1. 403GC Instructions by Category

Category	Base Instructions
Data Movement	load, store
Arithmetic / Logical	add, subtract, negate, multiply, divide, and, or, xor, nand, nor, xnor, sign extension, count leading zeros
Comparison	compare, compare logical, compare immediate
Branch	branch, branch conditional
Condition	condition register logical
Rotate/Shift	rotate, rotate and mask, shift left, shift right
Cache Control	invalidate, touch, zero, flush, store
Interrupt Control	write to external interrupt enable bit, move to/from machine state register, return from interrupt, return from critical interrupt
Processor Management	system call, synchronize, move to/from device control registers, move to/from special purpose registers

### Instruction Cache Unit

The instruction cache unit (ICU) is a two-way set-associative 2KB cache memory unit with enhancements to support branch prediction and folding. The ICU is organized as 64 sets of 2 lines, each line containing 16 bytes. A separate bypass path is available to handle cache-inhibited instructions and to improve performance during line fill operations.

The cache can send two cached instructions per cycle to the execution unit, allowing instructions to be folded out of the queue without interrupting normal instruction flow. When a branch instruction is folded and executed in parallel with another instruction, the ICU provides two more instructions to replace both of the instructions just executed so that bandwidth is balanced between the ICU and the execution unit.

### Data Cache Unit

The data cache unit is provided to minimize the access time of frequently used data items in main store. The 1KB cache is organized as a two-way set associative cache. There are 32 sets of 2 lines, each line containing 16 bytes of data. The cache features byte-writeability to improve the performance of byte and halfword store operations.

Cache operations are performed using a write-back strategy. A write-back cache only updates locations in main storage that corresponds to changed locations in the cache. Data is flushed from the cache to main storage whenever changed data needs to be removed from the cache to make room for other data.

The data cache may be disabled for a 128MB memory region via control bits in the data cache control register or on a per-page basis if the MMU is enabled for data translation. A separate bypass path is available to handle cache-inhibited data operations and to improve performance during line fill operations.

Cache flushing and filling are triggered by load, store, and cache control instructions executed by the processor. Cache blocks are loaded starting at the requested fullword, continuing to the end of

the block and then wrapping around to fill the remaining fullwords at the beginning of the block.

### DMA Controller

The four-channel DMA controller manages block data transfers in buffered, fly-by and memory-to-memory transfer modes with options for burst-mode operation. In fly-by and buffered modes, the DMA controller supports transactions between memory and peripheral devices.

Each DMA channel provides a control register, a source address register, a destination address register, a transfer count register, and a chained count register. Peripheral set-up cycles, wait cycles, and hold cycles can be programmed into each DMA channel control register. Each channel supports chaining operations. The DMA status register holds the status of all four channels.

### Exception Handling

Table 2 summarizes the 403GC exception priorities, types, and classes. Exceptions are generated by interrupts from internal and external peripherals, instructions, the internal timer facility, debug events or error conditions. Six external interrupt signals are provided on the 403GC: one critical and five general-purpose, all individually maskable.

All exceptions fall into three basic classes: asynchronous imprecise exceptions, synchronous precise exceptions, and asynchronous precise exceptions. Asynchronous exceptions are caused by events external to processor execution, while synchronous exceptions are caused by instructions.

Except for a system reset or machine check, all 403GC exceptions are handled precisely. Precise handling implies that the address of the excepting instruction (synchronous exceptions other than system call) or the address of the next sequential instruction (asynchronous exceptions and system call) is passed to the exception handling routine. Precise handling also implies that all instructions prior to the excepting instruction have completed execution and have written back their results.

Asynchronous imprecise exceptions include system resets and machine checks.

Synchronous precise exceptions include most debug exceptions, program exceptions, data storage violations, TLB misses, system calls, and alignment error exceptions. Asynchronous precise exceptions include the critical interrupt exception, external interrupts, and internal timer facility exceptions and some debug events.

Only one exception is handled at a time. If multiple exceptions occur simultaneously, they are handled in priority order.

The 403GC processes exceptions as reset, critical, or noncritical. Four exceptions are defined as critical: machine check exceptions, debug exceptions, exceptions caused by an active level on the critical interrupt pin, and the first time-out from the watchdog timer.

When a noncritical exception is taken, special purpose register Save/Restore 0 (SRR0) is loaded with the address of the excepting instruction (synchronous exceptions other than system call) or the next sequential instruction to be processed (asynchronous exceptions and system call). If the 403GC is executing a multicycle instruction (load/store multiple, load/store string, multiply or divide), the instruction is terminated and its address stored in SRR0. Save/Restore Register 1 (SRR1) is loaded with the contents of the machine state register. The

MSR is then updated to reflect the new context of the machine. The new MSR contents take effect beginning with the first instruction of the exception handling routine.

At the end of the exception handling routine, execution of a return from interrupt (rfi) instruction forces the contents of SRR0 and SRR1 to be loaded into the program counter and the MSR, respectively. Execution then begins at the address in the program counter.

The four critical exceptions are processed in a similar manner. When a critical exception is taken, SRR2 and SRR3 hold the next sequential address to be processed when returning from the exception and the contents of the machine state register, respectively. After the critical exception handling routine, return from critical interrupt (rfci) forces the contents of SRR2 and SRR3 to be loaded into the program counter and the MSR, respectively.

### Timers

The 403GC contains four timer functions: a time base, a programmable interval timer (PIT), a fixed interval timer (FIT), and a watchdog timer. The time base is a 64-bit counter incremented at the timer clock rate. The timer clock may be driven by either an internal signal equal to the processor clock rate or by a separate external timer clock pin. No interrupts are generated when the time base rolls over.

Table 2. 403GC Exception Priorities, Types and Classes

Priority	Exception Type	Exception Class
1	System Reset	Asynchronous imprecise
2	Machine Check	Asynchronous imprecise
3	Debug	Synchronous precise (except UDE and EXC)
4	Critical Interrupt	Asynchronous precise
5	WatchdogTimer Time-out	Asynchronous precise
6	Program Exception, Data Storage Exception, TLB Miss, and System Calls	Synchronous precise
7	Alignment Exceptions	Synchronous precise
8	External Interrupts	Asynchronous precise
9	Fixed Interval Timer	Asynchronous precise
10	Programmable Interval Timer	Asynchronous precise

The programmable interval timer is a 32-bit register that is decremented at the same rate as the time base is incremented. The user preloads the PIT register with a value to create the desired delay. When the register is decremented to zeros, the timer stops decrementing, a bit is set in the timer status register (TSR), and a PIT interrupt is generated. Optionally, the PIT can be programmed to reload automatically the last value written to the PIT register, after which the PIT begins decrementing again. The timer control register (TCR) contains the interrupt enable for the PIT interrupt.

The fixed interval timer generates periodic interrupts based on selected bits in the time base. Users may select one of four intervals for the timer period by setting the correct bits in the TCR. When the selected bit in the time base changes from 0 to 1, a bit is set in the TSR and a FIT interrupt is generated. The FIT interrupt enable is contained in the TCR.

The watchdog timer generates a periodic interrupt based on selected bits in the time base. Users may select one of four time periods for the interval and the type of reset generated if the watchdog timer expires twice without an intervening clear from software. If enabled, the watchdog timer generates a system reset unless an exception handler updates the watchdog timer status bit before the timer has completed two of the selected timer intervals.

### Serial Port

The 403GC serial port is capable of supporting RS232 standard serial communication, as well as high-speed execution (bit speed at a maximum of one-sixteenth of the SysClk processor clock rate). The serial clock which drives the serial port can come from the internal SysClk or an external clock source at the external serial clock pin (maximum of one-half the SysClk rate).

The 403GC serial port contains many features found only on advanced communications controllers, including the capability of being a peripheral for DMA transfers. An internal loopback mode supports diagnostic testing without requiring external hardware. An auto echo mode is included to retransmit received bits to the external device. Auto-resynchronization

after a line break and false start bit detection are also provided, as well as operating modes that allow the serial port to react to handshaking line inputs or control handshaking line outputs without software interaction. Program generation mode allows the serial port transmitter to be used for pulse width modulation with duty cycle variation controlled by frame size, baud rate, and data pattern.

### JTAG Port

The JTAG port has been enhanced to allow it to be used as a debug port. Through the JTAG test access port, debug software on a workstation or PC can single-step the processor and interrogate internal processor state to facilitate software debugging. The standard JTAG boundary-scan register allows testing of circuitry external to the chip, primarily the board interconnect. Alternatively, the JTAG bypass register can be selected when no other test data register needs to be accessed during a board-level test operation.

### Real-Time Debug Port

The real-time debug port supports tracing the instruction stream being executed out of the instruction cache in real time. The trace status signals provide trace information while in real-time trace debug mode. This mode does not alter the performance of the processor.

### P/N Code

Table 3. PPC403GC Part Numbers

MHz	Part Number	Package
25	PPC403GC-JA25C1	PQFP
	403GC-3BA25C1	PBGA
33	PPC403GC-JA33C1	PQFP
	403GC-3BA33C1	PBGA
40	PPC403GC-JA40C1	PQFP
	403GC-3BA40C1	PBGA

#### Notes:

1. The dash number indicates the speed version.
2. The characters in the dash number indicate reliability grade, package type (J or B), revision level (A), and commercial version (C), and the ratio of internal CPU core clock rate to external bus speed.
3. PQFP and PBGA versions are both reliability grade 3, but only the PBGA part numbers specify the grade.

Logic Symbol

Signals in brackets are multiplexed.

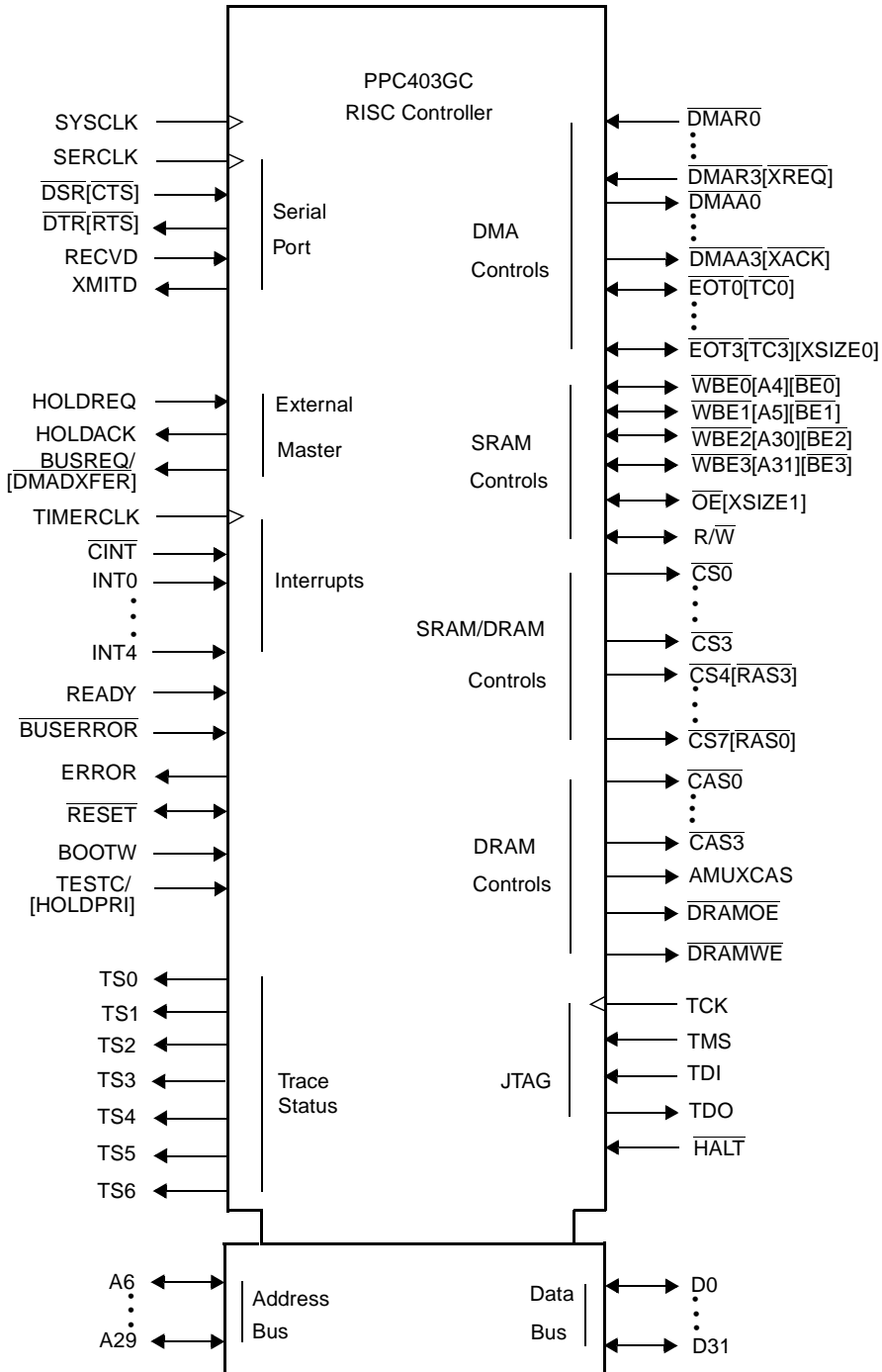

**Pin Functional Descriptions**

Active-low signals are shown with overbars:  $\overline{\text{DMAR0}}$ . Multiplexed signals are alphabetized under the first (unmultiplexed) signal names on the same pins. The logic symbol on the preceding page shows all 403GC signals arranged by functional groups.

Table 4. 403GC Signal Descriptions

Signal Name	Pin	Ball	I/O Type	Function
A6	92	K12	I/O	Address Bus Bit 6. When the 403GC is bus master, this is an address output from the 403GC. When the 403GC is not bus master, this is an address input from the external bus master, to determine bank register usage.
A7	93	K11	I/O	Address Bus Bit 7. See description of A6.
A8	94	J13	I/O	Address Bus Bit 8. See description of A6.
A9	95	J14	I/O	Address Bus Bit 9. See description of A6.
A10	96	J12	I/O	Address Bus Bit 10. See description of A6.
A11	97	J11	I/O	Address Bus Bit 11. See description of A6.
A12	98	H13	O	Address Bus Bit 12. When the 403GC is bus master, this is an address output from the 403GC.
A13	99	H14	O	Address Bus Bit 13. See description of A12.
A14	103	G14	O	Address Bus Bit 14. See description of A12.
A15	104	G13	O	Address Bus Bit 15. See description of A12.
A16	105	G11	O	Address Bus Bit 16. See description of A12.
A17	106	F14	O	Address Bus Bit 17. See description of A12.
A18	107	F12	O	Address Bus Bit 18. See description of A12.
A19	108	F13	O	Address Bus Bit 19. See description of A12.
A20	109	F11	O	Address Bus Bit 20. See description of A12.
A21	110	E14	O	Address Bus Bit 21. See description of A12.
A22	112	E13	I/O	Address Bus Bit 22. When the 403GC is bus master, this is an address output from the 403GC. When the 403GC is not bus master, this is an address input from the external bus master, to determine page crossings.
A23	113	E11	I/O	Address Bus Bit 23. See description of A22.
A24	114	D14	I/O	Address Bus Bit 24. See description of A22.
A25	115	D12	I/O	Address Bus Bit 25. See description of A22.
A26	116	D13	I/O	Address Bus Bit 26. See description of A22.
A27	117	C14	I/O	Address Bus Bit 27. See description of A22.
A28	118	C12	I/O	Address Bus Bit 28. See description of A22.



Table 4. 403GC Signal Descriptions

Signal Name	Pin	Ball	I/O Type	Function
A29	119	C13	I/O	Address Bus Bit 29. See description of A22.
AMuxCAS	139	A8	O	DRAM External Address Multiplexer Select. AMuxCAS controls the select logic on an external multiplexer. If AMuxCAS is low, the multiplexer should select the row address for the DRAM and when AMuxCAS is 1, the multiplexer should select the column address.
BootW	11	E1	I	Boot-up ROM Width Select. BootW is sampled while the $\overline{\text{Reset}}$ pin is active and again after $\overline{\text{Reset}}$ becomes inactive to determine the width of the boot-up ROM. If this pin is tied to logic 0 when sampled on reset, an 8-bit boot width is assumed. If BootW is tied to 1, a 32-bit boot width is assumed. For 16-bit boot widths, this pin should be tied to the $\overline{\text{RESET}}$ pin.
$\overline{\text{BusError}}$	12	E3	I	Bus Error Input. A logic 0 input to the $\overline{\text{BusError}}$ pin by an external device signals to the 403GC that an error occurred on the bus transaction. $\overline{\text{BusError}}$ is only sampled during the data transfer cycle or the last wait cycle of the transfer.
$\overline{\text{BusReq/DMADXFER}}$	135	A9	O	Bus Request. While HoldAck is active, BusReq is active when the 403GC has a bus operation pending and needs to regain control of the bus. DMA Data Transfer. When HoldAck is not active, $\overline{\text{DMADXFER}}$ indicates a valid data transfer cycle. For DMA use, $\overline{\text{DMADXFER}}$ controls burst-mode fly-by DMA transfers between memory and peripherals. $\overline{\text{DMADXFER}}$ is not meaningful unless a DMA Acknowledge signal ( $\overline{\text{DMAA0:3}}$ ) is active. For transfer rates slower than one transfer per cycle, $\overline{\text{DMADXFER}}$ is active for one cycle when one transfer is complete and the next one starts. For transfer rates of one transfer per cycle, $\overline{\text{DMADXFER}}$ remains active throughout the transfer.
$\overline{\text{CAS0}}$	142	C8	O	DRAM Column Address Select 0. $\overline{\text{CAS0}}$ is used with byte 0 of all DRAM banks.
$\overline{\text{CAS1}}$	143	A7	O	DRAM Column Address Select 1. $\overline{\text{CAS1}}$ is used with byte 1 of all DRAM banks.
$\overline{\text{CAS2}}$	144	B7	O	DRAM Column Address Select 2. $\overline{\text{CAS2}}$ is used with byte 2 of all DRAM banks.
$\overline{\text{CAS3}}$	145	D7	O	DRAM Column Address Select 3. $\overline{\text{CAS3}}$ is used with byte 3 of all DRAM banks.
$\overline{\text{CINT}}$	36	L2	I	Critical Interrupt. To initiate a critical interrupt, the user must maintain a logic 0 on the $\overline{\text{CINT}}$ pin for a minimum of one SysClk clock cycle followed by a logic 1 on the $\overline{\text{CINT}}$ pin for at least one SysClk cycle.
$\overline{\text{CS0}}$	155	C4	O	SRAM Chip Select 0. Bank register 0 controls an SRAM bank, $\overline{\text{CS0}}$ is the chip select for that bank.
$\overline{\text{CS1}}$	154	A4	O	SRAM Chip Select 1. See description of $\overline{\text{CS0}}$ but controls bank 1.

Table 4. 403GC Signal Descriptions

Signal Name	Pin	Ball	I/O Type	Function
$\overline{CS2}$	153	D5	O	SRAM Chip Select 2. See description of $\overline{CS0}$ but controls bank 2.
$\overline{CS3}$	152	B5	O	SRAM Chip Select 3. See description of $\overline{CS0}$ but controls bank 3.
$\overline{CS4/RAS3}$	151	C5	O	Chip Select 4/ DRAM Row Address Select 3. When bank register 4 is configured to control an SRAM bank, $\overline{CS4/RAS3}$ functions as a chip select. When bank register 4 is configured to control a DRAM bank, $\overline{CS4/RAS3}$ is the row address select for that bank.
$\overline{CS5/RAS2}$	148	B6	O	Chip Select 5/ DRAM Row Address Select 2. See description of $\overline{CS4/RAS3}$ but controls bank 5.
$\overline{CS6/RAS1}$	147	C6	O	Chip Select 6/ DRAM Row Address Select 1. See description of $\overline{CS4/RAS3}$ but controls bank 6.
$\overline{CS7/RAS0}$	146	A6	O	Chip Select 7/ DRAM Row Address Select 0. See description of $\overline{CS4/RAS3}$ but controls bank 7.
D0	42	N2	I/O	Data bus bit 0 (Most significant bit).
D1	43	P2	I/O	Data bus bit 1.
D2	44	N3	I/O	Data bus bit 2.
D3	45	P3	I/O	Data bus bit 3.
D4	46	N4	I/O	Data bus bit 4.
D5	47	M4	I/O	Data bus bit 5.
D6	48	P4	I/O	Data bus bit 6.
D7	51	P5	I/O	Data bus bit 7.
D8	52	M5	I/O	Data bus bit 8.
D9	53	L5	I/O	Data bus bit 9.
D10	54	N6	I/O	Data bus bit 10.
D11	55	P6	I/O	Data bus bit 11.
D12	56	M6	I/O	Data bus bit 12.
D13	57	L6	I/O	Data bus bit 13.
D14	58	N7	I/O	Data bus bit 14.
D15	62	M7	I/O	Data bus bit 15.
D16	63	P8	I/O	Data bus bit 16.
D17	64	N8	I/O	Data bus bit 17.
D18	65	L8	I/O	Data bus bit 18.
D19	66	P9	I/O	Data bus bit 19.
D20	67	M9	I/O	Data bus bit 20.
D21	68	N9	I/O	Data bus bit 21.

Table 4. 403GC Signal Descriptions

Signal Name	Pin	Ball	I/O Type	Function
D22	71	M10	I/O	Data bus bit 22.
D23	72	N10	I/O	Data bus bit 23.
D24	73	L10	I/O	Data bus bit 24.
D25	74	P11	I/O	Data bus bit 25.
D26	75	M11	I/O	Data bus bit 26.
D27	76	N11	I/O	Data bus bit 27.
D28	77	P12	I/O	Data bus bit 28.
D29	78	M12	I/O	Data bus bit 29.
D30	79	N12	I/O	Data bus bit 30.
D31	82	N13	I/O	Data bus bit 31.
$\overline{\text{DMAA0}}$	156	B4	O	DMA Channel 0 Acknowledge. $\overline{\text{DMAA0}}$ has an active level when a transaction is taking place between the 403GC and a peripheral.
$\overline{\text{DMAA1}}$	157	A3	O	DMA Channel 1 Acknowledge. See description of $\overline{\text{DMAA0}}$ .
$\overline{\text{DMAA2}}$	158	C3	O	DMA Channel 2 Acknowledge. See description of $\overline{\text{DMAA0}}$ .
$\overline{\text{DMAA3}}/\overline{\text{XACK}}$	159	B3	O	DMA Channel 3 Acknowledge / External Master Transfer Acknowledge. When the 403GC is bus master, this signal is $\overline{\text{DMAA3}}$ ; see description of $\overline{\text{DMAA0}}$ . When the 403GC is not the bus master, this signal is $\overline{\text{XACK}}$ , an output from the 403GC which has an active level when data is valid during an external bus master transaction.
$\overline{\text{DMAR0}}$	2	B2	I	DMA Channel 0 Request. External devices request a DMA transfer on channel 0 by putting a logic 0 on $\overline{\text{DMAR0}}$ .
$\overline{\text{DMAR1}}$	3	B1	I	DMA Channel 1 Request. See description of $\overline{\text{DMAR0}}$ .
$\overline{\text{DMAR2}}$	4	C2	I	DMA Channel 2 Request. See description of $\overline{\text{DMAR0}}$ .
$\overline{\text{DMAR3}}/\overline{\text{XREQ}}$	5	C1	I	DMA Channel 3 Request. When the 403GC is the bus master, external devices request a DMA transfer on channel 3 by putting a logic 0 on $\overline{\text{DMAR3}}$ . See description of $\overline{\text{DMAR0}}$ . When the 403GC is not the bus master, $\overline{\text{DMAR3}}$ is used as the $\overline{\text{XREQ}}$ input. The external bus master places a logic 0 on $\overline{\text{XREQ}}$ to initiate a transfer to the DRAM controlled by the 403GC DRAM controller.
$\overline{\text{DRAMOE}}$	137	D9	O	DRAM Output Enable. $\overline{\text{DRAMOE}}$ has an active level when either the 403GC or an external bus master is reading from a DRAM bank. This signal enables the selected DRAM bank to drive the data bus.
$\overline{\text{DRAMWE}}$	138	B8	O	DRAM Write Enable. $\overline{\text{DRAMWE}}$ has an active level when either the 403GC or an external bus master is writing to a DRAM bank.

Table 4. 403GC Signal Descriptions

Signal Name	Pin	Ball	I/O Type	Function
$\overline{DSR}/\overline{CTS}$	28	J2	I	Data Set Ready / Clear to Send. The function of this pin as either $\overline{DSR}$ or $\overline{CTS}$ is selectable via the Serial Port Configuration bit in the IOCR.
$\overline{DTR}/\overline{RTS}$	88	L14	O	Data Terminal Ready / Request to Send. The function of this pin as either $\overline{DTR}$ or $\overline{RTS}$ is selectable via the Serial Port Configuration bit in the IOCR.
$\overline{EOT0}/\overline{TC0}$	128	A11	I/O	End of Transfer 0 / Terminal Count 0. The function of the $\overline{EOT0}/\overline{TC0}$ is controlled via the $\overline{EOT}/\overline{TC}$ bit in the DMA Channel 0 Control Register. When $\overline{EOT0}/\overline{TC0}$ is configured as an End of Transfer pin, external users may stop a DMA transfer by placing a logic 0 on this input pin. When configured as a Terminal Count pin, the 403GC signals the completion of a DMA transfer by placing a logic 0 on this pin.
$\overline{EOT1}/\overline{TC1}$	131	A10	I/O	End of Transfer 1 / Terminal Count 1. See description of $\overline{EOT0}/\overline{TC0}$ .
$\overline{EOT2}/\overline{TC2}$	132	C10	I/O	End of Transfer 2 / Terminal Count 2. See description of $\overline{EOT0}/\overline{TC0}$ .
$\overline{EOT3}/\overline{TC3}/\overline{XSize0}$	133	D10	I/O	End of Transfer 3 / Terminal Count 3 / External Master Transfer Size 0. When the 403GC is bus master, this pin has the same function as $\overline{EOT0}/\overline{TC0}$ . When the 403GC is not bus master, $\overline{EOT3}/\overline{TC3}/\overline{XSize0}$ is used as one of two external transfer size input bits, $\overline{XSize0}:1$ .
Error	136	C9	O	System Error. Error goes to a logic 1 whenever a machine check error is detected in the 403GC. The Error pin then remains a logic 1 until the machine check error is cleared in the Exception Syndrome Register and/or Bus Error Syndrome Register.
GND	1	G7		Ground. All ground pins must be used.
	10	E2		Ground. All ground pins must be used.
	15	F1		Ground. All ground pins must be used.
	29	J4		Ground. All ground pins must be used.
	30	K1		Ground. All ground pins must be used.
	41	H7		Ground. All ground pins must be used.
	50	N5		Ground. All ground pins must be used.
	59	P7		Ground. All ground pins must be used.
	60	L7		Ground. All ground pins must be used.
	70	P10		Ground. All ground pins must be used.
81	H8		Ground. All ground pins must be used.	

Table 4. 403GC Signal Descriptions

Signal Name	Pin	Ball	I/O Type	Function
GND	90	K13		Ground. All ground pins must be used.
	101	G12		Ground. All ground pins must be used.
	102	H12		Ground. All ground pins must be used.
	111	E12		Ground. All ground pins must be used.
	121	G8		Ground. All ground pins must be used.
	130	B10		Ground. All ground pins must be used.
	141	C7		Ground. All ground pins must be used.
	150	A5		Ground. All ground pins must be used.
$\overline{\text{Halt}}$	9	D4	I	Halt from external debugger, active low.
HoldAck	134	B9	O	Hold Acknowledge. HoldAck outputs a logic 1 when the 403GC relinquishes its external buses to an external bus master. HoldAck outputs a logic 0 when the 403GC regains control of the bus.
HoldReq	14	F2	I	Hold Request. External bus masters can request the 403GC bus by placing a logic1 on this pin. The external bus master relinquishes the bus to the 403GC by deasserting HoldReq.
INT0	31	K3	I	Interrupt 0. INT0 is an interrupt input to the 403GC and users may program the pin to be either edge-triggered or level-triggered and may also program the polarity to be active high or active low. The IOCR contains the bits necessary to program the trigger type and polarity.
INT1	32	K2	I	Interrupt 1. See description of INT0.
INT2	33	K4	I	Interrupt 2. See description of INT0.
INT3	34	L1	I	Interrupt 3. See description of INT0.
INT4	35	L3	I	Interrupt 4. See description of INT0.
IVR	39			Interface voltage reference. When connected to 3.3V supply, allows the device to interface to an exclusively 3V system. When connected to 5V supply, allows the device to interface to 5V or mixed 3V/5V system. If any input or output connects to 5V system, this pin must be connected to 5V supply.
$\overline{\text{OE}}/\text{XSize1}$	126	B11	O/I	Output Enable / External Master Transfer Size 1. When the 403GC is bus master, $\overline{\text{OE}}$ enables the selected SRAMs to drive the data bus. The timing parameters of $\overline{\text{OE}}$ relative to the chip select, $\overline{\text{CS}}$ , are programmable via bits in the 403GC bank registers. When the 403GC is not bus master, $\overline{\text{OE}}/\text{XSize1}$ is used as one of two external transfer size input bits, XSize0:1.
Ready	13	E4	I	Ready. Ready is used to insert externally generated (device-paced) wait states into bus transactions. The Ready pin is enabled via the Ready Enable bit in 403GC bank registers.
RecvD	27	J3	I	Serial Port Receive Data.

Table 4. 403GC Signal Descriptions

Signal Name	Pin	Ball	I/O Type	Function
$\overline{\text{Reset}}$	91		I/O	$\overline{\text{Reset}}$ . A logic 0 input placed on this pin for eight SysClk cycles causes the 403GC to begin a system reset. When a system reset is invoked, the $\overline{\text{Reset}}$ pin becomes a logic 0 output for eight SysClk cycles.
$R/\overline{W}$	127	C11	I/O	Read / Write. When the 403GC is bus master, $R/\overline{W}$ is an output which is high when data is read from memory and low when data is written to memory. When the 403GC is not bus master, $R/\overline{W}$ is an input from the external bus master which indicates the direction of data transfer.
SerClk	26	J1	I	Serial Port Clock. Through the Serial Port Clock Source bit in the Input/Output Configuration register (IOCR), users may choose the serial port clock source from either the input on the SerClk pin or processor SysClk. The maximum allowable input frequency into SerClk is half the SysClk frequency.
SysClk	22	G3	I	SysClk is the processor system clock input. SysClk supports a 50/50 duty cycle clock input at the rated chip frequency.
TCK	6	D2	I	JTAG Test Clock Input. TCK is the clock source for the 403GC test access port (TAP). The maximum clock rate into the TCK pin is one half of the processor SysClk clock rate.
TDI	8	D1	I	Test Data In. The TDI is used to input serial data into the TAP. When the TAP enables the use of the TDI pin, the TDI pin is sampled on the rising edge of TCK and this data is input to the selected TAP shift register.
TDO	16	F3	O	Test Data Output. TDO is used to transmit data from the 403GC TAP. Data from the selected TAP shift register is shifted out on TDO.
TestA	23	H1	I	Reserved for manufacturing test. Tied low for normal operation.
$\overline{\text{TestB}}$	24	H2	I	Reserved for manufacturing test. Tied high for normal operation.
TestC/Hold-Pri	37	M1	I	TestC. Reserved for manufacturing test during the reset interval. While Reset is active, this signal should be tied low for normal operation. HoldReq Priority. When Reset is not active, this signal is sampled to determine the priority of the external bus master signal HoldReq. If HoldPri = 0 then the HoldReq signal is considered high priority, otherwise HoldReq is considered low priority.
TestD	38	M3	I	Reserved for manufacturing test. Tied low for normal operation.
TimerClk	25	H4	I	Timer Facility Clock. Through the Timer Clock Source bit in the Input/Output Configuration register (IOCR), users may choose the clock source for the Timer facility from either the input on the TimerClk pin or processor CoreClk. The maximum input frequency into TimerClk is half the CoreClk frequency.

Table 4. 403GC Signal Descriptions

Signal Name	Pin	Ball	I/O Type	Function
TMS	7	D3	I	Test Mode Select. The TMS pin is sampled by the TAP on the rising edge of TCK. The TAP state machine uses the TMS pin to determine the mode in which the TAP operates.
TS0	17	F4	O	Trace Status 0.
TS1	18	G2	O	Trace Status 1.
TS2	19	G1	O	Trace Status 2.
TS3	86	L13	O/I	Trace Status 3.
TS4	85	M14	O/I	Trace Status 4.
TS5	84	M13	O/I	Trace Status 5.
TS6	83	N14	O/I	Trace Status 6.
V <sub>DD</sub>	20	G4		Power. All power pins must be connected to 3.3V supply.
	21	H3		Power. All power pins must be connected to 3.3V supply.
	40	N1		Power. All power pins must be connected to 3.3V supply.
	49	L4		Power. All power pins must be connected to 3.3V supply.
	61	M8		Power. All power pins must be connected to 3.3V supply.
	69	L9		Power. All power pins must be connected to 3.3V supply.
	80	P13		Power. All power pins must be connected to 3.3V supply.
	89	L11		Power. All power pins must be connected to 3.3V supply.
	100	H11		Power. All power pins must be connected to 3.3V supply.
	120	B14		Power. All power pins must be connected to 3.3V supply.
	129	D11		Power. All power pins must be connected to 3.3V supply.
	140	D8		Power. All power pins must be connected to 3.3V supply.
	149	D6		Power. All power pins must be connected to 3.3V supply.
160	A2		Power. All power pins must be connected to 3.3V supply.	

Table 4. 403GC Signal Descriptions

Signal Name	Pin	Ball	I/O Type	Function
$\overline{\text{WBE0}}/\text{A4}/\text{BE0}$	122	B13	O//O	Write Byte Enable 0 / Address Bus Bit 4 / Byte Enable 0. When the 403GC is bus master, the write byte enable outputs, $\overline{\text{WBE0:3}}$ , select the active byte(s) in a memory write access to SRAM. The byte enables can also be programmed as read/write byte enables, depending on the mode set in the IOCR. Note 3 on page 33 summarizes the functional and timing differences in these signals when programmed as read/write byte enables. For 8-bit memory regions, $\overline{\text{WBE2}}$ and $\overline{\text{WBE3}}$ become address bits 30 and 31 and $\overline{\text{WBE0}}$ is the byte-enable line. For 16-bit memory regions, $\overline{\text{WBE2}}$ and $\overline{\text{WBE3}}$ become address bits 30 and 31 and $\overline{\text{WBE0}}$ and $\overline{\text{WBE1}}$ are the high byte and low byte enables, respectively. For 32-bit memory regions, $\overline{\text{WBE0:3}}$ are byte enables for bytes 0-3 on the data bus, respectively. When the 403GC is not bus master, $\overline{\text{WBE0:1}}$ are used as the A4:5 inputs (for bank register selection) and $\overline{\text{WBE2:3}}$ are used as the A30:31 inputs (for byte selection and page crossing detection).
$\overline{\text{WBE1}}/\text{A5}/\text{BE1}$	123	A13	O//O	Write Byte Enable 1 / Address Bus Bit 5 / Byte Enable 1. See description of $\overline{\text{WBE0}} / \text{A4}$ above.
$\overline{\text{WBE2}}/\text{A30}/\text{BE2}$	124	B12	O//O	Write Byte Enable 2 / Address Bus Bit 30 / Byte Enable 2. See description of $\overline{\text{WBE0}} / \text{A4}$ above.
$\overline{\text{WBE3}}/\text{A31}/\text{BE3}$	125	A12	O//O	Write Byte Enable 3 / Address Bus Bit 31 / Byte Enable 3. See description of $\overline{\text{WBE0}} / \text{A4}$ above.
XmitD	87	L12	O	Serial port transmit data.



Table 5. Signals Ordered by PQFP Pin Number

Pin	Signal Name	Pin	Signal Name	Pin	Signal Name	Pin	Signal Name	Pin	Signal Name
1	GND	33	INT2	65	D18	97	A11	129	V <sub>DD</sub>
2	$\overline{\text{DMAR0}}$	34	INT3	66	D19	98	A12	130	GND
3	$\overline{\text{DMAR1}}$	35	INT4	67	D20	99	A13	131	$\overline{\text{EOT1/TC1}}$
4	$\overline{\text{DMAR2}}$	36	$\overline{\text{CINT}}$	68	D21	100	V <sub>DD</sub>	132	$\overline{\text{EOT2/TC2}}$
5	$\overline{\text{DMAR3/XREQ}}$	37	TestC/HoldPri	69	V <sub>DD</sub>	101	GND	133	$\overline{\text{EOT3/TC3/XSize0}}$
6	TCK	38	TestD	70	GND	102	GND	134	HoldAck
7	TMS	39	IVR	71	D22	103	A14	135	BusReq/ DMADXFER
8	TDI	40	V <sub>DD</sub>	72	D23	104	A15	136	Error
9	$\overline{\text{Halt}}$	41	GND	73	D24	105	A16	137	$\overline{\text{DRAMOE}}$
10	GND	42	D0	74	D25	106	A17	138	$\overline{\text{DRAMWE}}$
11	BootW	43	D1	75	D26	107	A18	139	AMuxCAS
12	$\overline{\text{BusError}}$	44	D2	76	D27	108	A19	140	V <sub>DD</sub>
13	Ready	45	D3	77	D28	109	A20	141	GND
14	HoldReq	46	D4	78	D29	110	A21	142	$\overline{\text{CAS0}}$
15	GND	47	D5	79	D30	111	GND	143	$\overline{\text{CAS1}}$
16	TDO	48	D6	80	V <sub>DD</sub>	112	A22	144	$\overline{\text{CAS2}}$
17	TS0	49	V <sub>DD</sub>	81	GND	113	A23	145	$\overline{\text{CAS3}}$
18	TS1	50	GND	82	D31	114	A24	146	$\overline{\text{CS7/RAS0}}$
19	TS2	51	D7	83	TS6	115	A25	147	$\overline{\text{CS6/RAS1}}$
20	V <sub>DD</sub>	52	D8	84	TS5	116	A26	148	$\overline{\text{CS5/RAS2}}$
21	V <sub>DD</sub>	53	D9	85	TS4	117	A27	149	V <sub>DD</sub>
22	SysClk	54	D10	86	TS3	118	A28	150	GND
23	TestA	55	D11	87	XmitD	119	A29	151	$\overline{\text{CS4/RAS3}}$
24	$\overline{\text{TestB}}$	56	D12	88	$\overline{\text{DTR/RTS}}$	120	V <sub>DD</sub>	152	$\overline{\text{CS3}}$
25	TimerClk	57	D13	89	V <sub>DD</sub>	121	GND	153	$\overline{\text{CS2}}$
26	SerClk	58	D14	90	GND	122	$\overline{\text{WBE0/A4/BE0}}$	154	$\overline{\text{CS1}}$
27	RecvD	59	GND	91	$\overline{\text{Reset}}$	123	$\overline{\text{WBE1/A5/BE1}}$	155	$\overline{\text{CS0}}$
28	$\overline{\text{DSR/CTS}}$	60	GND	92	A6	124	$\overline{\text{WBE2/A30/BE2}}$	156	DMAA0
29	GND	61	V <sub>DD</sub>	93	A7	125	$\overline{\text{WBE3/A31/BE3}}$	157	DMAA1
30	GND	62	D15	94	A8	126	$\overline{\text{OE/XSize1}}$	158	DMAA2
31	INT0	63	D16	95	A9	127	$\overline{\text{R/W}}$	159	$\overline{\text{DMAA3/XACK}}$
32	INT1	64	D17	96	A10	128	$\overline{\text{EOT0/TC0}}$	160	V <sub>DD</sub>

PQFP Mechanical Drawing (Top View)

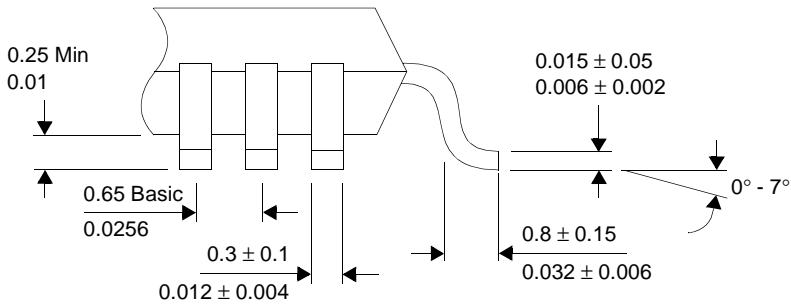
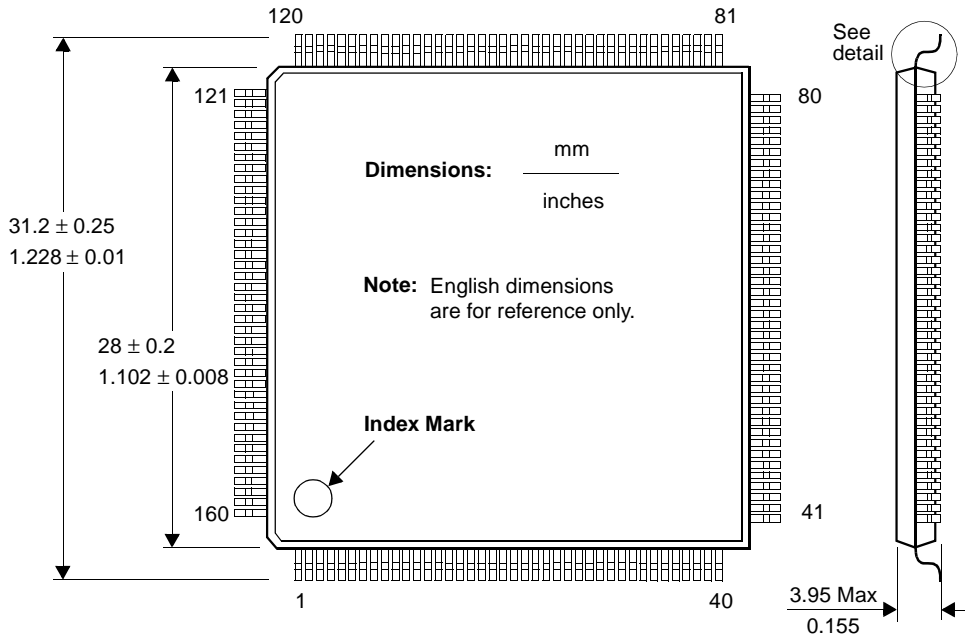
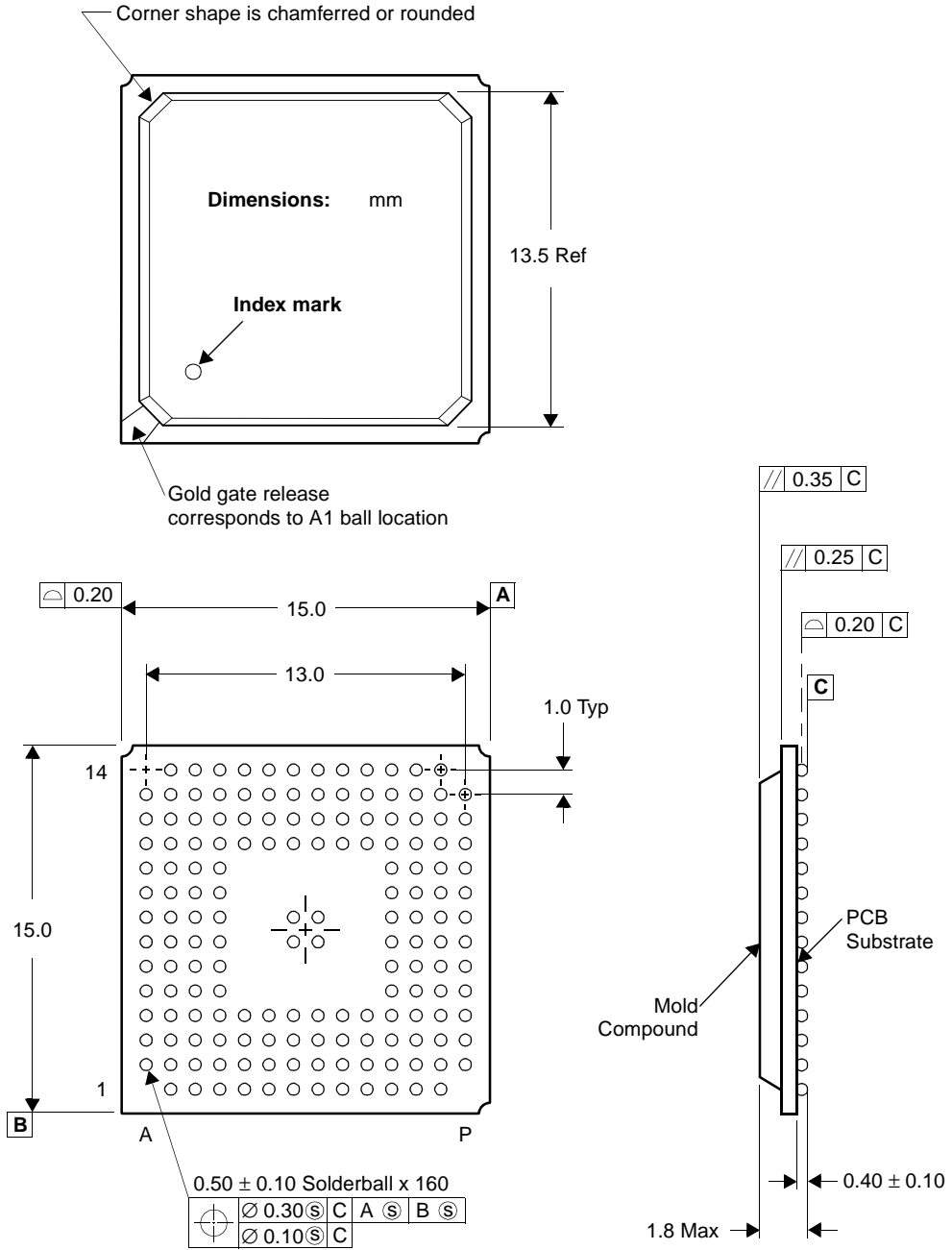

Table 6. Signals Ordered by PBGA Ball Assignment

Ball	Signal Name	Ball	Signal Name	Ball	Signal Name	Ball	Signal Name	Ball	Signal Name
A2	V <sub>DD</sub>	C7	GND	F3	TDO	J13	A8	M9	D20
A3	$\overline{\text{DMAA1}}$	C8	$\overline{\text{CAS0}}$	F4	TS0	J14	A9	M10	D22
A4	$\overline{\text{CS1}}$	C9	Error	F11	A20	K1	GND	M11	D26
A5	GND	C10	$\overline{\text{EOT2/TC2}}$	F12	A18	K2	INT1	M12	D29
A6	$\overline{\text{CS7/RAS0}}$	C11	R $\overline{\text{W}}$	F13	A19	K3	INT0	M13	TS5
A7	$\overline{\text{CAS1}}$	C12	A28	F14	A17	K4	INT2	M14	TS4
A8	AMuxCAS	C13	A29	G1	TS2	K11	A7	N1	V <sub>DD</sub>
A9	BusReq/ DMADXFER	C14	A27	G2	TS1	K12	A6	N2	D0
A10	$\overline{\text{EOT1/TC1}}$	D1	TDI	G3	SysClk	K13	GND	N3	D2
A11	$\overline{\text{EOT0/TC0}}$	D2	TCK	G4	V <sub>DD</sub>	K14	$\overline{\text{Reset}}$	N4	D4
A12	$\overline{\text{WBE3/A31/BE3}}$	D3	TMS	G7	GND	L1	INT3	N5	GND
A13	WBE1/A5/BE1	D4	Halt	G8	GND	L2	$\overline{\text{CINT}}$	N6	D10
B1	$\overline{\text{DMAR1}}$	D5	$\overline{\text{CS2}}$	G11	A16	L3	INT4	N7	D14
B2	$\overline{\text{DMAR0}}$	D6	V <sub>DD</sub>	G12	GND	L4	V <sub>DD</sub>	N8	D17
B3	$\overline{\text{DMAA3/XACK}}$	D7	$\overline{\text{CAS3}}$	G13	A15	L5	D9	N9	D21
B4	$\overline{\text{DMAA0}}$	D8	V <sub>DD</sub>	G14	A14	L6	D13	N10	D23
B5	$\overline{\text{CS3}}$	D9	$\overline{\text{DRAMOE}}$	H1	TestA	L7	GND	N11	D27
B6	$\overline{\text{CS5/RAS2}}$	D10	$\overline{\text{EOT3/TC3/}}$ XSize0	H2	TestB	L8	D18	N12	D30
B7	$\overline{\text{CAS2}}$	D11	V <sub>DD</sub>	H3	V <sub>DD</sub>	L9	V <sub>DD</sub>	N13	D31
B8	$\overline{\text{DRAMWE}}$	D12	A25	H4	TimerClk	L10	D24	N14	TS6
B9	HoldAck	D13	A26	H7	GND	L11	V <sub>DD</sub>	P2	D1
B10	GND	D14	A24	H8	GND	L12	XmitD	P3	D3
B11	$\overline{\text{OE/XSize1}}$	E1	BootW	H11	V <sub>DD</sub>	L13	TS3	P4	D6
B12	$\overline{\text{WBE2/A30/BE2}}$	E2	GND	H12	GND	L14	$\overline{\text{DTR/RTS}}$	P5	D7
B13	WBE0/A4/BE0	E3	$\overline{\text{BusError}}$	H13	A12	M1	TestC/HoldPri	P6	D11
B14	V <sub>DD</sub>	E4	Ready	H14	A13	M2	IVR	P7	GND
C1	$\overline{\text{DMAR3/XREQ}}$	E11	A23	J1	SerClk	M3	TestD	P8	D16
C2	$\overline{\text{DMAR2}}$	E12	GND	J2	$\overline{\text{DSR/CTS}}$	M4	D5	P9	D19
C3	$\overline{\text{DMAA2}}$	E13	A22	J3	RecvD	M5	D8	P10	GND
C4	$\overline{\text{CS0}}$	E14	A21	J4	GND	M6	D12	P11	D25
C5	$\overline{\text{CS4/RAS3}}$	F1	GND	J11	A11	M7	D15	P12	D28
C6	$\overline{\text{CS6/RAS1}}$	F2	HoldReq	J12	A10	M8	V <sub>DD</sub>	P13	V <sub>DD</sub>

PBGA Mechanical Drawing (Top View)



### Package Thermal Specifications

The 403GC is designed to operate within the case temperature range from -40°C to 120°C. Thermal resistance values are shown in Table 7:

Table 7. Thermal Resistance (°C/Watt)

Parameter	Airflow-ft/min (m/sec)		
	0 (0)	100 (0.51)	200 (1.02)
$\theta_{JC}$ Junction to case	2	2	2
$\theta_{CA}$ Case to ambient			
PQFP (no heatsink)	37.2	31.6	29.8
PBGA (no heatsink)	30		

**Notes:**

1. Case temperature  $T_{mC}$  is measured at top center of case surface with device soldered to circuit board.
2.  $T_{mA} = T_{mC} - P \times \theta_{CA}$ , where  $T_{mA}$  is ambient temperature.
3.  $T_{mCMax} = T_{mJMax} - P \times \theta_{JC}$ , where  $T_{mJMax}$  is maximum junction temperature and P is power consumption.
4. The above assumes that the chip is mounted on a card with at least one signal and two power planes.

### ELECTRICAL SPECIFICATIONS

#### Absolute Maximum Ratings

The absolute maximum ratings in Table 8 below are stress ratings only. Operation at or beyond these maximum ratings may cause permanent damage to the device.

Table 8. 403GC Maximum Ratings

Parameter	Maximum Rating
Supply voltage with respect to GND	-0.5V to +3.8V
Voltage on other pins with respect to GND	-0.5V to +5.5V
Case temperature under bias	-40°C to +120°C
Storage temperature	-65°C to +150°C

#### Operating Conditions

The 403GC can interface to either 3V or 5V technologies. The range for supply voltages is specified for five-percent margins relative to a nominal 3.3V power supply.

Device operation beyond the conditions specified in Table 9 is not recommended. Extended operation beyond the recommended conditions may affect device reliability:

Table 9. Operating Conditions

Symbol	Parameter	Min	Max	Unit
$V_{DD}$	Supply voltage: PPC403GC-JA25/33/40 403GC-3BA25/33/40	3.14	3.47	V
$F_C$	Clock frequency <sup>1</sup> : PPC403GC-JA25/3BA25 PPC403GC-JA33/3BA33 PPC403GC-JA40/3BA40	0	25	MHz
$T_{mC}$	Case temperature under bias: PPC403GC-JA25/33/40 403GC-3BA25/33/40	-40	85	°C

**Note:**

1. These frequencies do not account for  $T_{CS}$ . See Table 12.

#### Power Considerations

Power dissipation is determined by operating frequency, temperature, and supply voltage, as well as external source/sink current requirements. Typical power dissipation is 0.2 W at 25 MHz, 0.26 W at 33 MHz, or 0.32 W at 40 MHz,  $T_{mC} = 55^\circ\text{C}$ , and  $V_{CC} = 3.3\text{ V}$ , with an average 10pF capacitive load.

Estimated supply current as a function of frequency is shown in the figure, "Supply Current vs Operating Frequency," on page 30. Derating curves are provided in the section, "Output Derating for Capacitance and Voltage," on page 28.

#### Recommended Connections

Power and ground pins should all be connected to separate power and ground planes in the circuit board to which the 403GC is mounted. Unused input pins must be tied inactive, either high or low.

The interface voltage reference (IVR) pin should be connected to 3.3V supply if all signal pins connecting to the 403GC pins operate at 3V levels. If any signal pin connecting to the 403GC operates with 5V levels, the IVR pin should be connected to 5V supply.

DC Specifications

Table 10. 403GC DC Characteristics

Symbol	Parameter	Min	Max	Units
$V_{IL}$	Input low voltage (except for SysClk)	GND - 0.1	0.8	V
$V_{ILC}$	Input low voltage for SysClk	GND - 0.1	0.8	V
$V_{IH}$	Input high voltage (except for SysClk) <sup>1</sup>	2.0	$V_{IVR} + 0.1$	V
$V_{IHC}$	Input high voltage for SysClk <sup>1</sup>	2.0	$V_{IVR} + 0.1$	V
$V_{OL}$	Output low voltage		0.4	V
$V_{OH}$	Output high voltage	2.4	$V_{DD}$	V
$I_{OH}$	Output high current		2	mA
$I_{OL}$	Output low current		4	mA
$I_{LI}$	Input leakage current		50	$\mu$ A
$I_{LO}$	Output leakage current		10	$\mu$ A
$I_{CC}$	Supply current ( $I_{CC\ Max}$ at $F_C$ of 25 MHz) <sup>2</sup>		200	mA
	Supply current ( $I_{CC\ Max}$ at $F_C$ of 33 MHz) <sup>2</sup>		260	mA
	Supply current ( $I_{CC\ Max}$ at $F_C$ of 40 MHz) <sup>2, 3</sup>		315	mA

Notes:

- $V_{IVR}$  is the interface voltage reference to which the IVR pin is tied to select either a 3.3V or 5V interface. For additional information, see "Recommended Connections," on page 21.
- The 403GC drives its outputs to the level of  $V_{DD}$  and, when not driving, the 403GC outputs can be pulled up to 5V by other devices in a system if the 403GC IVR pin has been tied to 5V properly.
- $I_{CC\ Max}$  is measured at  $T_{mC} = 85^\circ\text{C}$ , worst-case recommended operating conditions for frequency and voltage as specified in Table 9 on page 21, and a capacitive load of 50 pF.

Table 11. 403GC I/O Capacitance

Symbol	Parameter	Min	Max	Units
$C_{IN}$	Input capacitance (except for SysClk)		5	pF
$C_{INC}$	Input capacitance for SysClk		25	pF
$C_{OUT}$	Output capacitance <sup>1</sup>		7	pF
$C_{I/O}$	I/O pin capacitance		8	pF

Note:

- $C_{Out}$  is specified as the load capacitance of a floating output in high impedance.

AC Specifications

Clock timing and switching characteristics are specified in accordance with recommended operating conditions in Table 9. AC specifications are characterized at  $V_{DD} = 3.14\text{V}$  and  $T_J = 85^\circ\text{C}$  with the 50pF test load shown in the figure at right. Derating of outputs for capacitive loading is shown in the figure "Output Derating for Capacitance and Voltage," on page 28.

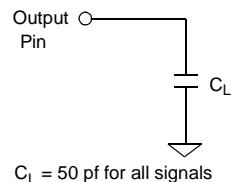

**SysClk Timing**

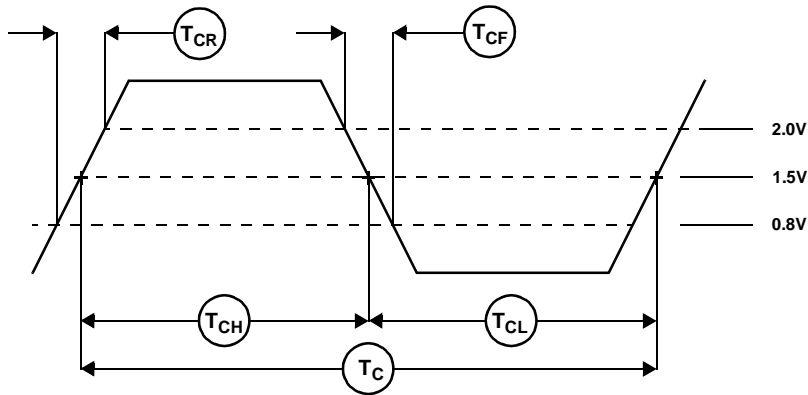

Table 12. 403GC System Clock Timing

Symbol	Parameter	25 MHz		33 MHz		40 MHz		Units
		Min	Max	Min	Max	Min	Max	
$F_C$	SysClk clock input frequency <sup>1</sup>		25	33		40		MHz
$T_C$	SysClk clock period <sup>1</sup>	40		30		25		ns
$T_{CS}$	Clock edge stability <sup>2</sup>		0.2		0.2		0.2	ns
$T_{CH}$	Clock input high time	16		13		11		ns
$T_{CL}$	Clock input low time	16		13		11		ns
$T_{CR}$	Clock input rise time <sup>3</sup>	0.5	2.5	0.5	2.5	0.5	1.5	ns
$T_{CF}$	Clock input fall time <sup>3</sup>	0.5	2.5	0.5	2.5	0.5	1.5	ns

**Notes:**

1. These values do not include the allowable tolerance for clock edge instability represented by  $T_{CS}$ .
2. Cycle-to-cycle jitter allowed between any two edges.
3. Rise and fall times measured between 0.8V and 2.0V.

**Timer Clock and Serial Port Timing Characteristics**

Table 13. 403GC Timer Clock and Serial Clock Timings

Symbol	Parameter	Min	Max	Units
$F_{SC}$	TimerClk, SerClk input frequency		$0.5 F_C$	MHz
$T_{SC}$	TimerClk, SerClk period	$2T_C$		ns
$T_{SCH}$	TimerClk, SerClk input high time	$1/F_C$		ns
$T_{SCL}$	TimerClk, SerClk input low time	$1/F_C$		ns

**Notes:**

1. Maximum input frequency of TimerClk and SerClk must be less than or equal to half of SysClk input frequency.
2. TimerClk and SerClk input high times must be greater than or equal to SysClk period  $T_C$ .
3. TimerClk and SerClk input low times must also be greater than or equal to SysClk period  $T_C$ .

Table 14. 403GC Serial Port Output Timings

Symbol	Parameter	25 MHz		33 MHz		40 MHz		Units
		$T_{OHMin}$	$T_{OVMax}$	$T_{OHMin}$	$T_{OVMax}$	$T_{OHMin}$	$T_{OVMax}$	
$T_{OH}, T_{OV}$	Output hold, output valid time							
	$T_{OH1}, T_{OV1} \overline{DTR}/RTS$		14		13		12	ns
	$T_{OH2}, T_{OV2} XmitD$		12		11		10	

**Note:**

1. Output times are measured with a standard 50 pF capacitive load, unless otherwise noted.

**Input Setup and Hold Waveform**

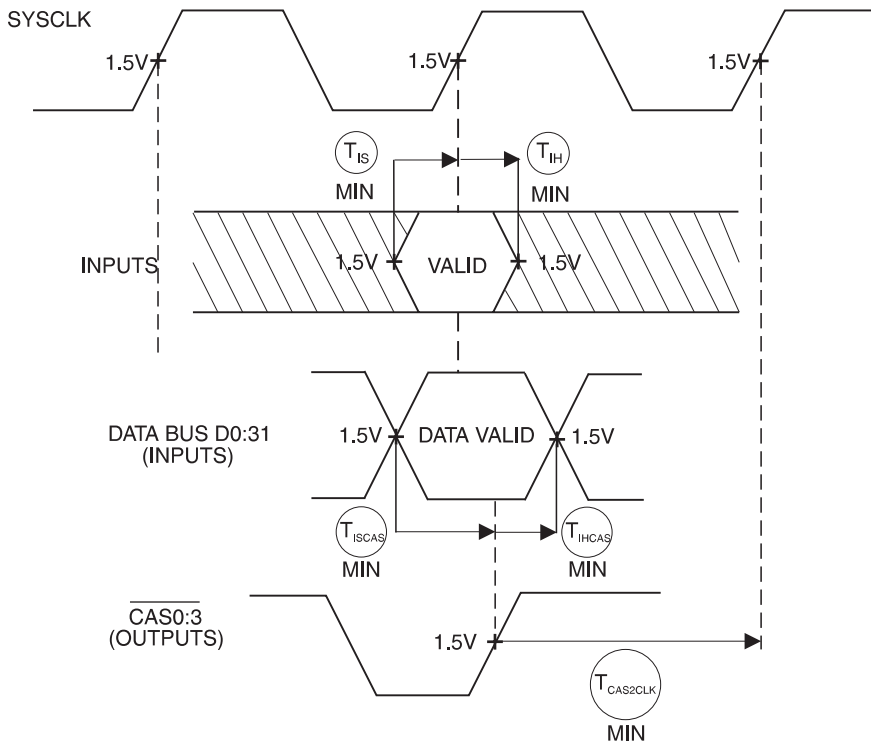

**Notes:**

1. The 403GC may be programmed to latch data from the data bus either on the rise of SysClk or the rise of  $\overline{CAS}$ . When the 403GC is programmed to latch data on  $\overline{CAS}$ , bit 26 of the I/O control register (IOCR) is set to 1.
2.  $T_{CAS2CLK} \geq 15.5$  ns. The capacitive load on the CAS outputs must not delay the  $\overline{CAS}$  low-to-high transition such that the period from the  $\overline{CAS}$  rising edge to the next SysClk rising edge becomes less than 15.5 ns. The maximum value of  $\overline{CAS}$  capacitive loading can be determined by using the output time for  $\overline{CAS}$  from Table 17 on page 27, and applying the appropriate derating factor for your application. See the figure, "Output Derating for Capacitance and Voltage," on page 28.



Table 15. 403GC Synchronous Input Timings

Symbol	Parameter	25 MHz		33 MHz		40 MHz		Units
		Min	Max	Min	Max	Min	Max	
T <sub>IS</sub>	Input setup:							
	T <sub>IS1</sub>	A4:11,A22:31	4		3		3	
	T <sub>IS2</sub>	$\overline{\text{BusError}}$	5		5		5	
	T <sub>IS3</sub>	D0:31 (to SysClk)	5		4		4	
	T <sub>ISCAS</sub>	D0:31 (to $\overline{\text{CAS}}$ )	2		2		2	
	T <sub>IS4</sub>	HoldPri	3		3		3	ns
	T <sub>IS5</sub>	HoldReq	4		3		3	
	T <sub>IS6</sub>	R/W	3		3		3	
	T <sub>IS7</sub>	Ready	6		5		5	
	T <sub>IS8</sub>	$\overline{\text{XReq}}$	5		4		4	
T <sub>IS9</sub>	XSize0:1	5		4		4		
T <sub>IH</sub>	Input hold:							
	T <sub>IH1</sub>	A4:11,A22:31	2		2		2	
	T <sub>IH2</sub>	$\overline{\text{BusError}}$	2		2		2	
	T <sub>IH3</sub>	D0:31 (after SysClk)	2		2		2	
	T <sub>IHCAS</sub>	D0:31 (after $\overline{\text{CAS}}$ )	3		3		3	
	T <sub>IH4</sub>	HoldPri	2		2		2	ns
	T <sub>IH5</sub>	HoldReq	2		2		2	
	T <sub>IH6</sub>	R/W	2		2		2	
	T <sub>IH7</sub>	Ready	2		2		2	
	T <sub>IH8</sub>	$\overline{\text{XReq}}$	2		2		2	
T <sub>IH9</sub>	XSize0:1	2		2		2		
T <sub>R,F</sub>	Rise/fall time	0.5	2.5	0.5	2.5	0.5	2.5	ns

**Note:**

1. Data bus setup and hold times for DRAM  $\overline{\text{CAS}}$  mode are measured relative to  $\overline{\text{CAS}}$  deactivation.

Table 16. 403GC Asynchronous Input Timings

Symbol	Parameter	25 MHz		33 MHz		40 MHz		Units
		Min	Max	Min	Max	Min	Max	
T <sub>IS</sub>	Input setup time							
	T <sub>IS10</sub>	$\overline{\text{CINT}}$	5		3		3	
	T <sub>IS11</sub>	DMAR0:3	3		3		3	
	T <sub>IS12</sub>	EOT0:3	3		3		3	ns
	T <sub>IS13</sub>	$\overline{\text{HALT}}$	3		3		3	
	T <sub>IS14</sub>	INT0:4	6		5		5	
	T <sub>IS15</sub>	Reset	8		8		8	

Table 16. 403GC Asynchronous Input Timings

Symbol	Parameter	25 MHz		33 MHz		40 MHz		Units
		Min	Max	Min	Max	Min	Max	
$T_{IH}$	Input hold time							
$T_{IH10}$	$\overline{CINT}$	$T_C$		$T_C$		$T_C$		ns
$T_{IH11}$	$\overline{DMAR0:3}$	$T_C$		$T_C$		$T_C$		
$T_{IH12}$	$\overline{EOT0:3}$	$T_C$		$T_C$		$T_C$		
$T_{IH13}$	$\overline{HALT}$	$T_C$		$T_C$		$T_C$		
$T_{IH14}$	$\overline{INT0:4}$	$T_C$		$T_C$		$T_C$		
$T_{IH15}$	Reset	Note 1, 2		Note 1, 2		Note 1, 2		

**Notes:**

1. During a system-initiated reset,  $\overline{Reset}$  must be taken low for a minimum of 2048 SysClk cycles.
2. The BootW input has a maximum rise time requirement of 10 ns when it is tied to Reset.
3. Input hold times are measured at 3.47V and  $T_J = 0^\circ\text{C}$ .

**Output Delay and Float Timing Waveform**

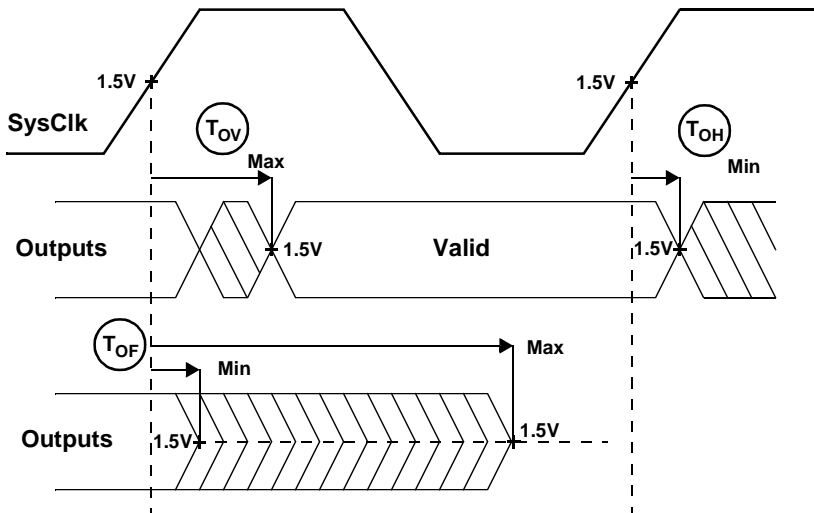

Table 17. 403GC Synchronous Output Timings

Symbol	Parameter	25 MHz		33 MHz		40 MHz		Units
		T <sub>OHMin</sub>	T <sub>OVMax</sub>	T <sub>OHMin</sub>	T <sub>OVMax</sub>	T <sub>OHMin</sub>	T <sub>OVMax</sub>	
T <sub>OH</sub> , T <sub>OV</sub>	Output hold, output valid time							
	T <sub>OH1</sub> , T <sub>OV1</sub> A6:31	4	15	4	13	4	11	
	T <sub>OH2</sub> , T <sub>OV2</sub> AMuxCAS	3	11	3	11	3	10	
	T <sub>OH3</sub> , T <sub>OV3</sub> BusReq	3	12	3	11	3	10	
	T <sub>OH4</sub> , T <sub>OV4</sub> $\overline{\text{CAS0:3}}$	4	13	4	12	4	11	
	T <sub>OH5</sub> , T <sub>OV5</sub> $\overline{\text{CS0:7}}$	2	13	2	11	2	10	
	T <sub>OH6</sub> , T <sub>OV6</sub> $\overline{\text{D0:31}}$	4	16	4	15	4	14	
	T <sub>OH7</sub> , T <sub>OV7</sub> $\overline{\text{DMAA0:3}}$	3	11	3	10	3	9	
	T <sub>OH8</sub> , T <sub>OV8</sub> $\overline{\text{DMADXFER}}$	3	13	3	11	3	10	
	T <sub>OH9</sub> , T <sub>OV9</sub> $\overline{\text{DRAMOE}}$	3	11	3	11	3	10	
	T <sub>OH10</sub> , T <sub>OV10</sub> $\overline{\text{DRAMWE}}$	2	10	3	10	3	9	
	T <sub>OH11</sub> , T <sub>OV11</sub> Error	4	14	4	12	4	12	ns
	T <sub>OH12</sub> , T <sub>OV12</sub> HoldAck	3	12	3	11	3	10	
	T <sub>OH13</sub> , T <sub>OV13</sub> $\overline{\text{OE}}$	3	11	3	10	3	9	
	T <sub>OH14</sub> , T <sub>OV14</sub> $\overline{\text{RAS0:3}}$	3	12	3	11	3	10	
	T <sub>OH15</sub> , T <sub>OV15</sub> $\overline{\text{RAS0:3}}$ (Early)	12	22	11	20	11	18	
	T <sub>OH16</sub> , T <sub>OV16</sub> Reset	3	14	3	12	3	12	
	T <sub>OH17</sub> , T <sub>OV17</sub> $\overline{\text{R/W}}$	3	11	3	10	3	9	
	T <sub>OH18</sub> , T <sub>OV18</sub> $\overline{\text{TC0:3}}$	3	13	3	12	3	11	
	T <sub>OH19</sub> , T <sub>OV19</sub> $\overline{\text{TS0:6}}$	4	30	4	25	4	22	
	T <sub>OH20</sub> , T <sub>OV20</sub> $\overline{\text{WBE0:3}}$ (BE0:3)	3	12	3	11	3	10	
	T <sub>OH21</sub> , T <sub>OV21</sub> $\overline{\text{XAck}}$	3	13	3	12	3	11	
T <sub>OF</sub>	Output float time	Min	Max	Min	Max	Min	Max	
	T <sub>OF1</sub> A6:31	2	10	2	9	2	9	
	T <sub>OF2</sub> $\overline{\text{CS0:7}}$	3	12	3	10	3	10	
	T <sub>OF3</sub> $\overline{\text{D0:31}}$	3	11	3	9	3	9	ns
	T <sub>OF4</sub> $\overline{\text{OE}}$	3	12	3	10	3	10	
	T <sub>OF5</sub> Reset	2	8	2	7	2	7	
	T <sub>OF6</sub> $\overline{\text{R/W}}$	3	12	3	10	3	10	
	T <sub>OF7</sub> $\overline{\text{TC0:3}}$	3	12	3	10	3	10	
	T <sub>OF8</sub> $\overline{\text{WBE0:3}}$ (BE0:3)	3	12	3	10	3	10	
T <sub>CAS</sub>	Available $\overline{\text{CAS}}$ access time	Min	Max	Min	Max	Min	Max	
	2-1-1 access mode (Note )	0.5T <sub>C</sub> -2.5		0.5T <sub>C</sub> - 2.5		0.5T <sub>C</sub> - 2.5		ns
	3-2-2 access mode (Note )	1.5T <sub>C</sub> -2.5		1.5T <sub>C</sub> -2.5		1.5T <sub>C</sub> -2.5		

**Notes:**

- For normal  $\overline{\text{RAS}}$  and  $\overline{\text{CAS}}$  timing, T<sub>OH</sub> is relative to the rising edge of SysClk and T<sub>OV</sub> is relative to the falling edge of SysClk. In early  $\overline{\text{RAS}}$  mode, T<sub>OH</sub> is relative to the rising edge of SysClk.  $\overline{\text{CAS}}$  access time assumes a SysClk 50% duty cycle.
- In early  $\overline{\text{RAS}}$  mode, the  $\overline{\text{RAS}}$  output delay varies with the 403GC operating frequency. Use the following equation to determine the worst-case output delay for this signal: T<sub>OVMax</sub> = 12 ns + T<sub>c</sub>/4; T<sub>OHMin</sub> remains unchanged. Valid for T<sub>c</sub> greater than 30 ns and less than 80 ns.
- When initiating a system reset, the 403GC pulls the Reset output low for 2048 cycles minimum and then samples to determine whether Reset is held low externally. Thirty-two cycles after Reset has been sampled as low, the 403GC begins its internal reset.
- Output times are measured with a standard 50 pF capacitive load, unless otherwise noted. Output hold times are measured at 3.47V and T<sub>J</sub> = 10°C.
- All output hold and float times are guaranteed by design and not tested.

Output Derating for Capacitance and Voltage

Output Propagation Delay Derating

Derating Equations for Output Delays:

1.  $\Delta t_{p_{LH}}(C_L, V) = t_{p_{LH}\Delta C} + t_{p_{LH}\Delta V}$
2.  $\Delta t_{p_{HL}}(C_L, V) = t_{p_{HL}\Delta C} + t_{p_{HL}\Delta V}$
3.  $\Delta t_{p_{ZL5V}}(C_L, V) = t_{p_{ZL}\Delta C} + t_{p_{HL}\Delta V}$

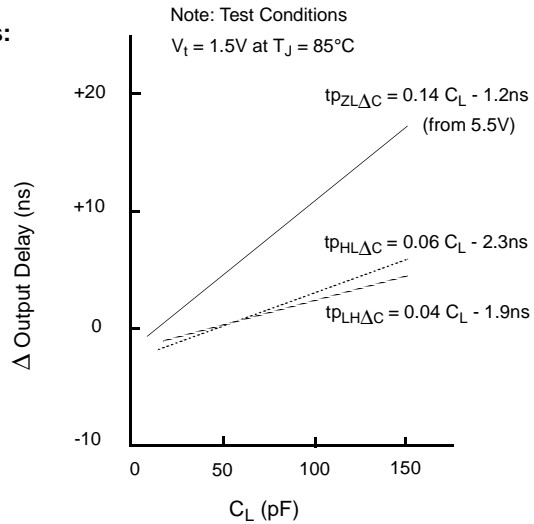

Output Propagation Delay Derating vs Output Voltage Level

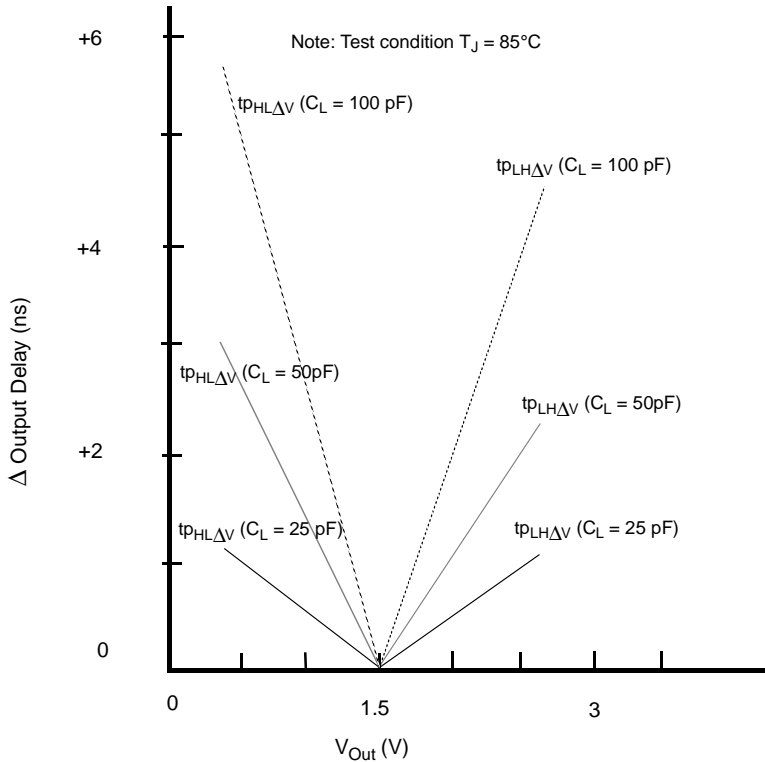

**Output Rise and Fall Time Derating**

**Derating Equations for Output Rise and Fall Times:**

- 4.  $t_r(C_L) = 2ns + tp_{r\Delta C}$
- 5.  $t_f(C_L) = 2.5ns + tp_{f\Delta C}$

**Output Transition Time Derating**

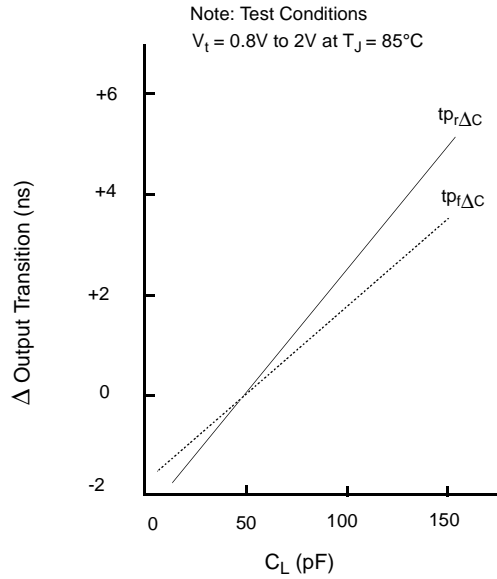

**Output Voltage vs Output Current**

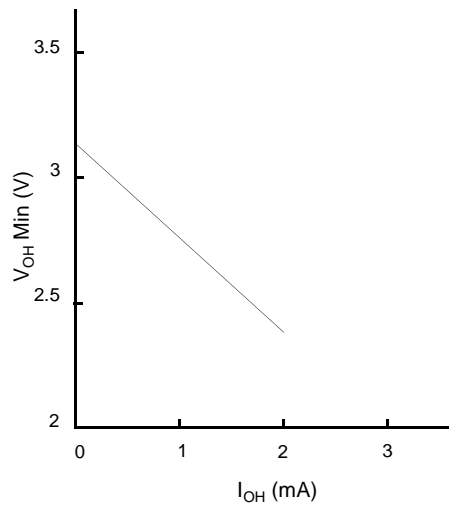
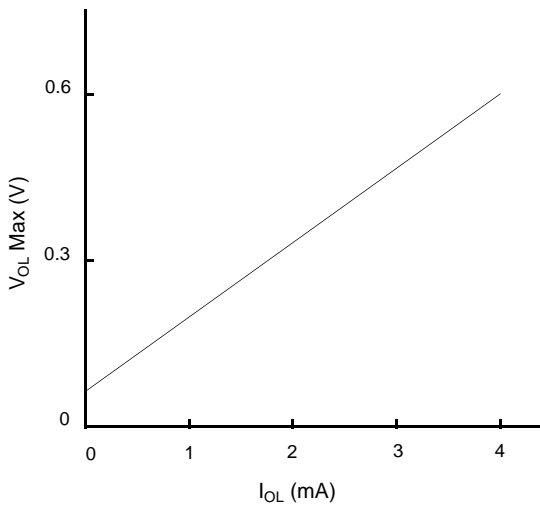

Note: Test conditions 3.14V at  $T_J = 85^\circ C$

Receiver Input Voltage vs DC Input Current

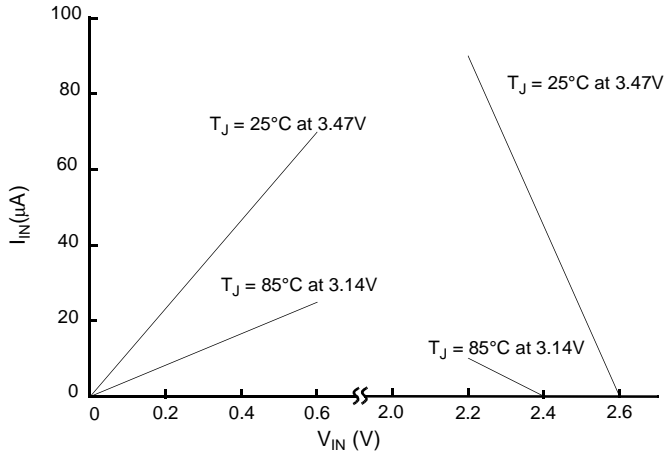

Note:

- Applies to receivers for asynchronous inputs on pins 2-9, 11,13, 23, 25-28, 31-38, and 91, and synchronous inputs on pins 5, 12, and 14.

Receiver Noise Sensitivity

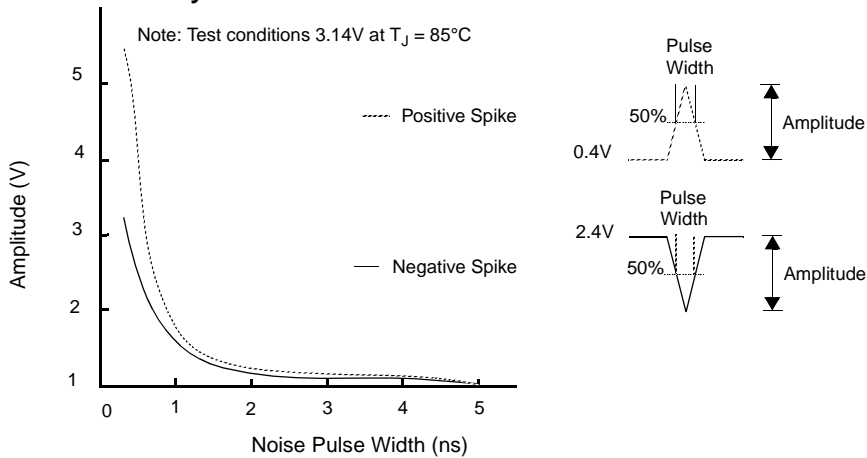

Supply Current vs Operating Frequency

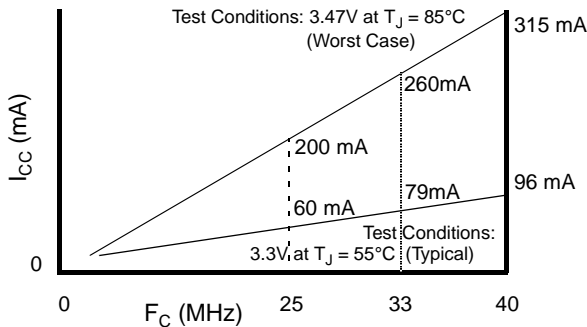

## Reset and HoldAck

The following table summarizes the states of signals on output pins when  $\overline{\text{Reset}}$  or HoldAck is active.

Table 18. Signal States During Reset or Hold Acknowledge

Signal Names	State When $\overline{\text{Reset}}$ Active	State When HoldAck Active
A6:29	Floating	Floating (set to input mode)
AMuxCAS	Inactive (low)	Operable (see note 1)
BusReq	Inactive (low)	Operable (see note 1)
$\overline{\text{CAS0:3}}$	Inactive (high)	Operable (see notes 1 and 2)
$\overline{\text{CS0:3}}$	Floating	Floating
$\overline{\text{CS4:7/RAS3:0}}$	Floating	$\overline{\text{CS}}$ floating, $\overline{\text{RAS}}$ operable (notes 1 and 2)
D0:31	Floating	Floating (external master drives bus)
$\overline{\text{DMAA0:3}}$	Inactive (high)	Inactive (high)
$\overline{\text{XAck}}$	Inactive (high)	Operable (see note 1)
$\overline{\text{DRAMOE}}$	Inactive (high)	Operable (see notes 1 and 2)
$\overline{\text{DRAMWE}}$	Inactive (high)	Operable (see notes 1 and 2)
Error	Inactive (low)	Operable (see note 1)
HoldAck	Inactive (low)	Active
$\overline{\text{OE}}$	Floating	Floating (input for XSize1)
$\overline{\text{Reset}}$	Floating unless initiating system reset	Floating unless initiating system reset
R/ $\overline{\text{W}}$	Floating	Floating (set to input)
$\overline{\text{TC0:2}}$	Floating (set to input)	Inactive (high)
$\overline{\text{TC3}}$	Floating (set to input)	Floating (input for XSize0)
TDO	Floating	Operable (see note 1)
TS0:6	Inactive (low)	Operable (see note 1)
$\overline{\text{WBE0:3}}$	Floating	Operable (inputs for A4:5, A30:31)
XmitD	Inactive (high)	Operable (see note 1)

### Note:

- Signal may be active while HoldAck is asserted, depending on the operation being performed by the 403GC.

## BUS WAVEFORMS

The waveforms in this section represent external bus operations, including SRAM and DRAM accesses, DMA transfers, and external master operations.

### Write Byte Enable Encoding

The 403GC provides four write byte enable signals ( $\overline{\text{WBE0:3}}$ ) to support 8-, 16-, and 32-bit devices, as shown in Table 19. For an eight-bit memory region,  $\overline{\text{WBE2:3}}$  are encoded as A30:31 and  $\overline{\text{WBE0}}$  is the byte-enable line. For a 16-bit region,  $\overline{\text{WBE0}}$  is the high-byte enable,  $\overline{\text{WBE1}}$  is the low-byte enable and  $\overline{\text{WBE2:3}}$  are encoded as A30:31. For a 32-bit region, address bits 6:29 select the word address and  $\overline{\text{WBE0:3}}$  select data bytes 0:3, respectively.

Table 19. Write Byte Enable Encoding

	Transfer Size	Address	$\overline{WBE0} = \overline{WE}$	$\overline{WBE1} = 1$	$\overline{WBE2} = A30$	$\overline{WBE3} = A31$
<b>8-Bit Bus Width</b>	Byte	0	0	1	0	0
	Byte	1	0	1	0	1
	Byte	2	0	1	1	0
	Byte	3	0	1	1	1
	Transfer Size	Address	$\overline{WBE0} = \overline{BHE}$	$\overline{WBE1} = \overline{BLE}$	$\overline{WBE2} = A30$	$\overline{WBE3} = A31$
<b>16-Bit Bus Width</b>	Half-word	0	0	0	0	0
	Half-word	2	0	0	1	0
	Byte	0	0	1	0	0
	Byte	1	1	0	0	1
	Byte	2	0	1	1	0
	Byte	3	1	0	1	1
	Transfer Size	Address	$\overline{WBE0}$	$\overline{WBE1}$	$\overline{WBE2}$	$\overline{WBE3}$
<b>32-Bit Bus Width</b>	Word	0	0	0	0	0
	Half-word	0	0	0	1	1
	Half-word	2	1	1	0	0
	Byte	0	0	1	1	1
	Byte	1	1	0	1	1
	Byte	2	1	1	0	1
	Byte	3	1	1	1	0

### Address Bus Multiplexing

To support DRAM memories with differing configurations and bus widths, the 403GC provides an internally multiplexed address bus controlled by the BIU. Table 20 shows the multiplexed address outputs referenced by waveforms later in this section.

Table 20. Multiplexed Address Outputs

<b>Address Pins</b>	A11	A12	A13	A14	A15	A16	A17	A18	A19	A20	A21	A22	A23	A24	A25	A26	A27	A28	A29
Addr Bits Out in RAS Cycle	a6	a7	a8	a9	a10	a11	a12	a13	a12	a13	a14	a15	a16	a17	a18	a19	a20	a21	a22
Addr Bits Out in $\overline{CAS}$ Cycle	xx	a6	a7	a8	a9	a10	a11	a12	a21	a22	a23	a24	a25	a26	a27	a28	a29	a30	a31

When the 403GC is bus master and there are no bus operations in progress, the states of the address bus outputs are determined by the setting of IOCR[ATC]. If this bit is set to zero, the address bus will be placed in high impedance. If this bit is set to one, the last address held in the BIU address register will be driven out on the address bus until bus operations resume.



SRAM Read-Write-Read with Zero Wait and One Hold

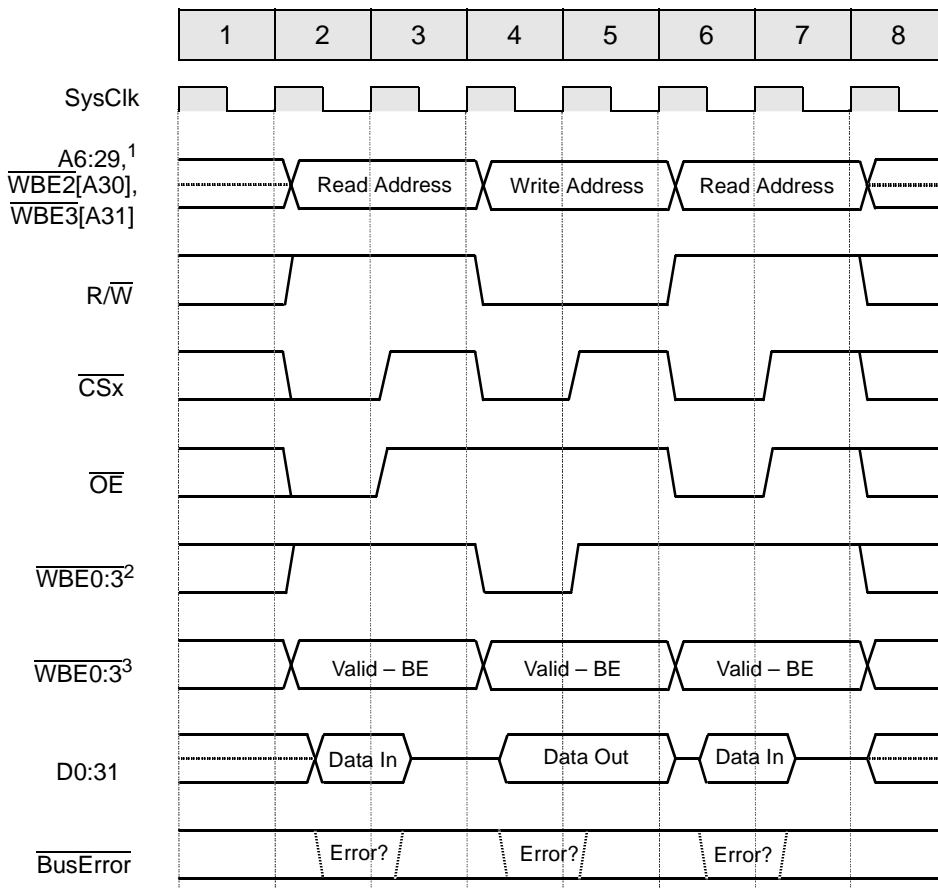

Bank Register Bit Settings

SLF	Burst Mode	Bus Width	Ready Enable	Wait States	Cson	OEon	WEon	WEoff	Hold
Bit 13	Bit 14	Bits 15:16	Bit 17	Bits 18:23	Bit 24	Bit 25	Bit 26	Bit 27	Bits 28:30
0 or 1	0	xx	0	00 0000	0	0	0	0	001

Notes:

1. WBE2:3 are address bits 30:31 if the bus width is programmed as byte or halfword.
2. See Table 19 on page 32 for WBE signal definitions based on bus width.
3. WBE signals can be read/write byte enables based on the setting of a control bit in the IOCR. When programmed as read/write byte enables, these outputs will indicate valid bytes of the bus for both read and write operations. In addition, the timing of these outputs will match the timing of the address bus, and the WBE<sub>ON</sub> and WBE<sub>OFF</sub> parameters will be ignored.

SRAM, ROM, or I/O Write Request with Wait and Hold

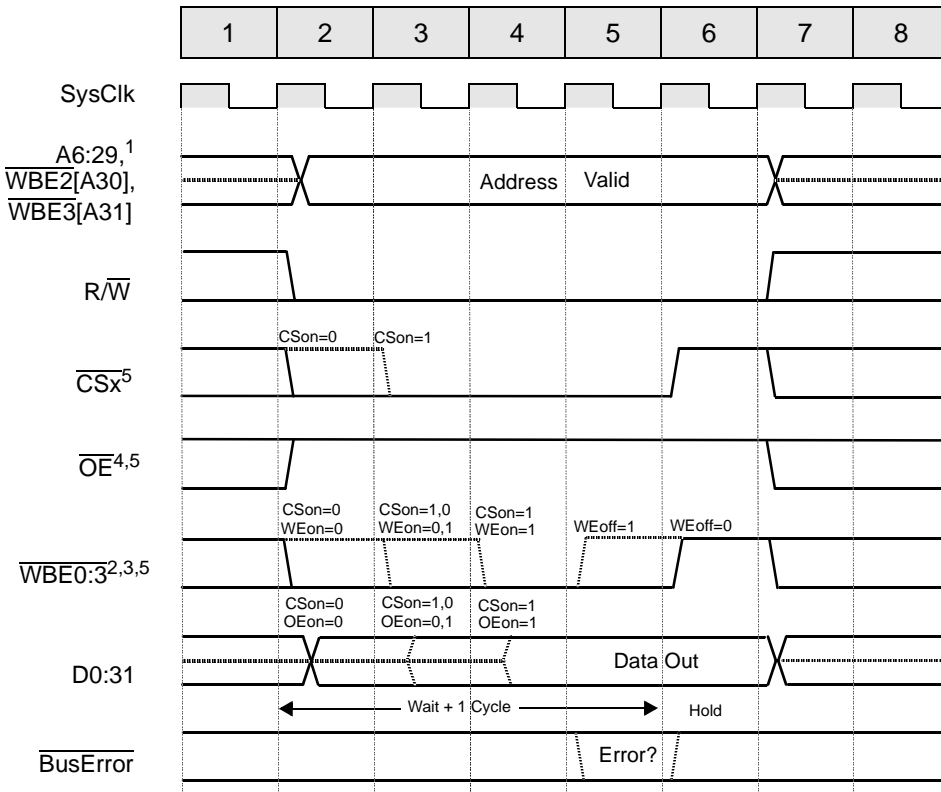

Bank Register Bit Settings

SLF	Burst Mode	Bus Width	Ready Enable	Wait States	CSon	OEon	WEon	WEOff	Hold
Bit 13	Bit 14	Bits 15:16	Bit 17	Bits 18:23	Bit 24	Bit 25	Bit 26	Bit 27	Bits 28:30
0 or 1	0	xx	0	00 0011	0 or 1	0 or 1	0 or 1	0 or 1	001

Notes:

- WBE2:3 are address bits 30:31 if the bus width is programmed as byte or halfword.
- See Table 19 for WBE signal definitions based on bus width.
- WBE signals can be read/write byte enables based on the setting of a control bit in the IOCR. See waveform and note 3 on page 33.
- 403GCWait must be programmed to a value  $\geq (CSon + WEon + WEOff)$  and  $\geq (CSon + OEon + WEOff)$ .  
If Wait  $> (CSon + WEon)$  and  $> (CSon + OEon)$ , then all signals retain the values shown in cycle 4 until the Wait time expires.
- If Hold is programmed  $> 001$ , all signals retain the values shown in cycle 6 until the Hold timer expires.

SRAM, ROM, or I/O Read Request, Wait Extended with Ready

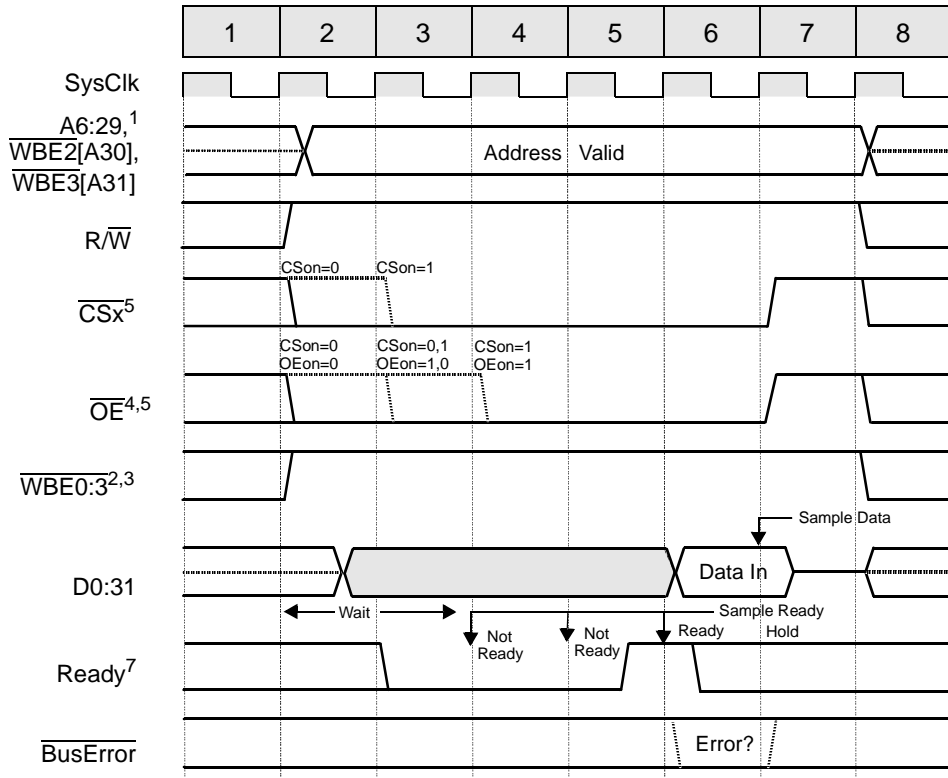

Bank Register Bit Settings

SLF	Burst Mode	Bus Width	Ready Enable	Wait States	CSon	OEon	WEon	WEoff	Hold
Bit 13	Bit 14	Bits 15:16	Bit 17	Bits 18:23	Bit 24	Bit 25	Bit 26	Bit 27	Bits 28:30
0 or 1	0	xx	1	00 0010	0 or 1	0 or 1	0 or 1	x	001

Notes:

1.  $\overline{WBE2:3}$  are address bits 30:31 if the bus width is programmed as byte or halfword.
2. See Table 19 on page 32 for  $\overline{WBE}$  signal definitions based on bus width.
3.  $\overline{WBE}$  signals can be read/write byte enables based on the setting of a control bit in the IOCR. See waveform and note 3 on page 33.
4. Wait must be programmed to a value  $\geq (CSon + OEon)$ . If  $Wait > (CSon + OEon)$ , then all signals will retain the values shown in cycle 4 until the Wait timer expires.
5. If Hold is programmed  $> 001$ , all 403GC output signals retain the values shown in cycle 7 until the Hold timer expires.
6. If  $Wait = 00\ 0000$ , the Ready input is ignored and single-cycle transfers occur. If  $Wait = 00\ 0001$ , Ready is sampled starting in cycle 2. If  $Wait > 00\ 0001$ , Ready is sampled starting after the Wait cycles have expired.
7. The Ready input can be synchronous or asynchronous based on the setting of a control bit in the IOCR. When Ready is synchronous, data is captured one cycle after Ready is sampled active. When Ready is asynchronous, data is transferred in the third cycle after Ready is sampled active.
8. If the Ready input has not been sampled active within 128 cycles from the start of the bus operation, and the device-paced timeout disable in the IOCR is not set to one, the operation will terminate and a timeout error will occur.

SRAM, ROM or I/O Burst Read with Wait and Hold

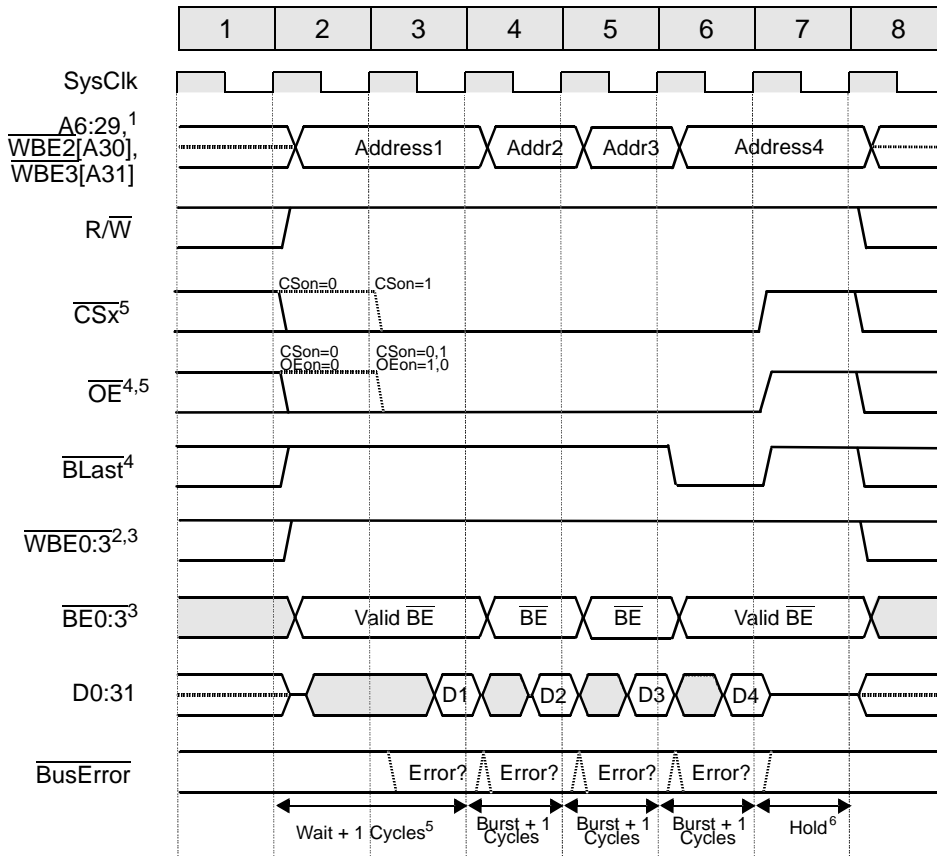

Bank Register Bit Settings

SLF	Burst Mode	Bus Width	Ready Enable	Wait States	Burst Wait	Cson	OEon	WEon	WEoff	Hold
Bit 13	Bit 14	Bits 15:16	Bit 17	Bits 18:21	Bits 22:23	Bit 24	Bit 25	Bit 26	Bit 27	Bits 28:30
0 or 1	1	xx	0	0001	00	0 or 1	0 or 1	x	x	001

Notes:

1. WBE2:3 are address bits 30:31 if the bus width is programmed as byte or halfword.
2. See Table 19 on page 32 for WBE signal definitions based on bus width.
3. See waveform and note 3 on page 33. WBE signals can be read/write byte enables based on the setting of a control bit in the IOCR. See waveform and note 3 on page 33.
4. Wait must be programmed to a value  $\geq (Cson + OEon)$ . If  $Wait > (Cson + OEon)$ , then all signals will retain the values shown in cycle 3 until the Wait timer expires.
5. If Hold is programmed  $> 001$ , all 403GC output signals retain the values shown in cycle 7 until the Hold timer expires.

SRAM, ROM or I/O Burst Write with Wait, Burst Wait, and Hold

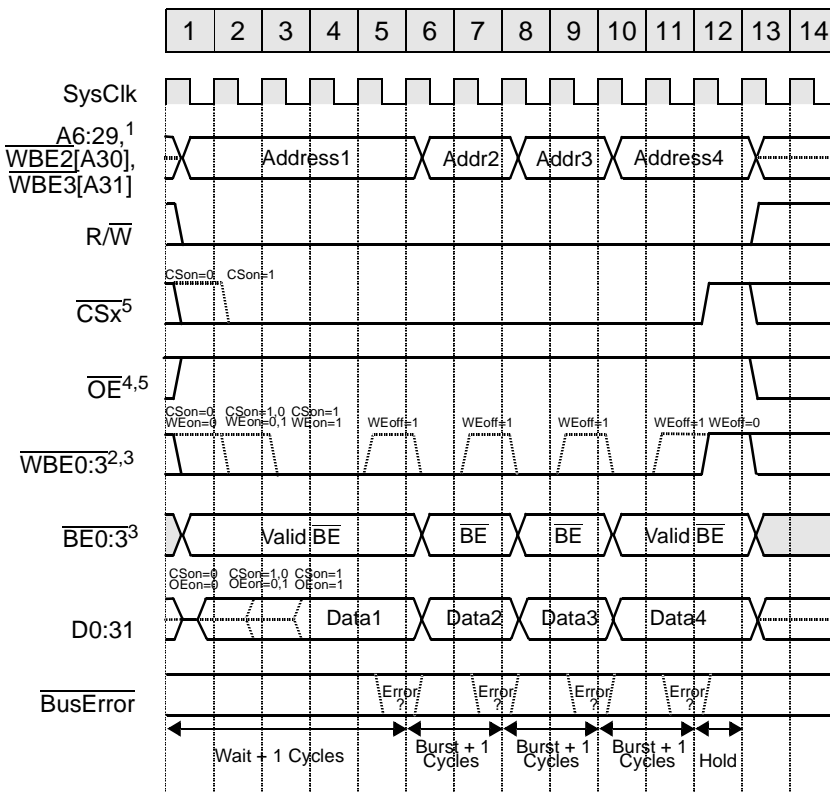

Bank Register Bit Settings

SLF	Burst Mode	Bus Width	Ready Enable	Wait States	Burst Wait	C <sub>Son</sub>	O <sub>Eon</sub>	W <sub>Eon</sub>	W <sub>Eoff</sub>	Hold
Bit 13	Bit 14	Bits 15:16	Bit 17	Bits 18:21	Bits 22:23	Bit 24	Bit 25	Bit 26	Bit 27	Bits 28:30
0 or 1	1	xx	0	0100	01	0 or 1	0 or 1	0 or 1	0 or 1	001

Notes:

- WBE2:3 are address bits 30:31 if the bus width is programmed as byte or halfword.
- See Table 19 on page 32 for WBE signal definitions based on bus width.
- See waveform and note 3 on page 33. WBE signals can be read/write byte enables based on the setting of a control bit in the IOCR. See waveform and note 3 on page 33.
- Wait must be programmed to a value  $\geq (C_{Son} + W_{Eon} + W_{Eoff})$  and  $\geq (C_{Son} + O_{Eon} + W_{Eoff})$ . If  $Wait > (C_{Son} + W_{Eon})$  and  $> (C_{Son} + O_{Eon})$ , then all signals retain the values shown in cycle 3 until the Wait timer expires.
- If Hold is programmed  $> 001$ , all 403GC output signals retain the values shown in cycle 12 until the Hold timer expires.

DRAM 2-1-1-1 Page Mode Read

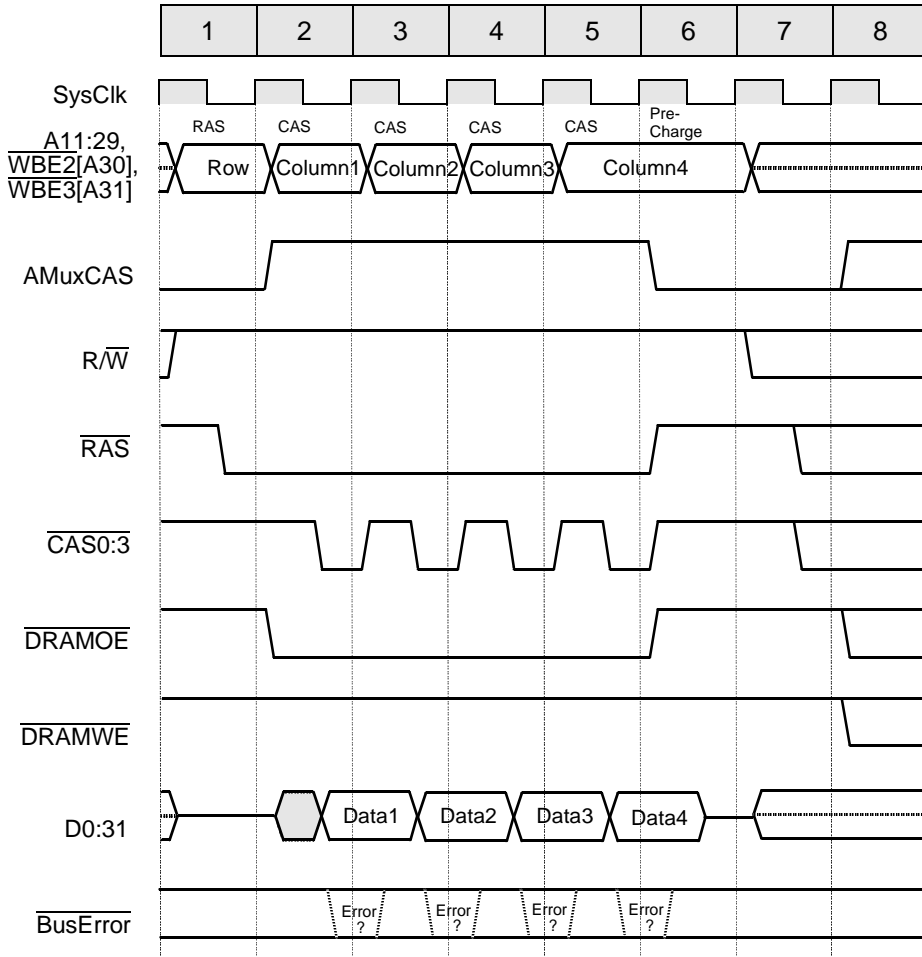

Bank Register Bit Settings

SLF	ERM	Bus Width	Ext Mux	RAS-to-CAS	Refresh Mode	Page Mode	First Access	Burst Access	Prechg Cycles	Refresh RAS	Refresh Rate
Bit 13	Bit 14	Bits 15:16	Bit 17	Bit 18	Bit 19	Bit 20	Bits 21:22	Bits 23:24	Bit 25	Bit 26	Bits 27:30
0 or 1	0	xx	x	0	0	1	00	00	0	x	xxxx

Notes:

- For burst access, the addresses represented by Columns 1 to 4 does not necessarily indicate that they are in incremental address order. Typically, burst access is target word first.
- If internal mux mode is used, address bits A11:29 represent address bits described in Table 20 on page 32.
- During internal mux mode access, A6:10 retain their unmuxed values.
- If external mux mode is used, A11:29 are unaffected and do not change between  $\overline{\text{CAS}}$  and  $\overline{\text{RAS}}$  cycles.
- If bus width is programmed as byte or half-word,  $\overline{\text{WBE2:3}}$  represent address bits A30:31 regardless of mux mode.
- $\overline{\text{WBE0:1}}$  are always ones during DRAM transfers.

**DRAM 3-2-2-2 Page Mode Write**

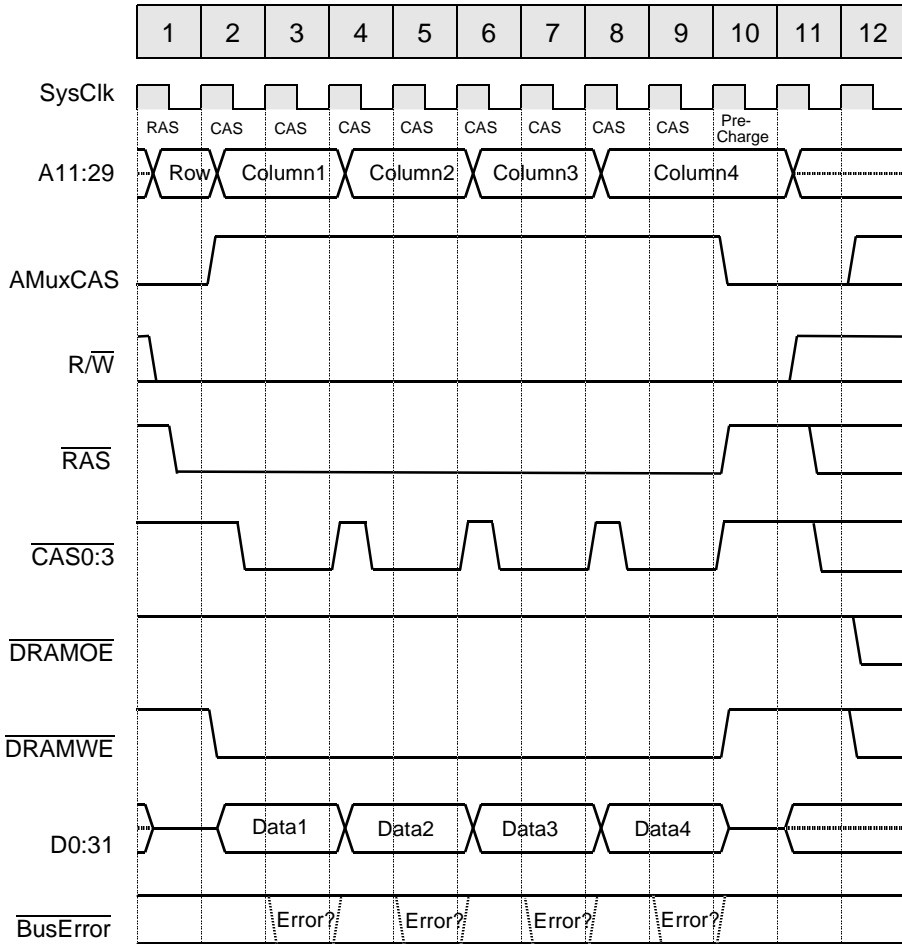

**Bank Register Bit Settings**

SLF	ERM	Bus Width	Ext Mux	RAS-to-CAS	Refresh Mode	Page Mode	First Access	Burst Access	Prechg Cycles	Refresh RAS	Refresh Rate
Bit 13	Bit 14	Bits 15:16	Bit 17	Bit 18	Bit 19	Bit 20	Bits 21:22	Bits 23:24	Bit 25	Bit 26	Bits 27:30
0 or 1	0	xx	x	0	0	1	01	01	0	x	xxxx

**Notes:**

1. For burst access, the addresses represented by Columns 1 to 4 do not necessarily indicate that they are in incremental address order. Typically, burst access is target word first.
2. If internal mux mode is used, address bits A11:29 represent address bits described in Table 20 on page 32.
3. During internal mux mode access, A6:10 retain their unmuxed values.
4. If external mux mode is used, A11:29 are unaffected and do not change between  $\overline{\text{CAS}}$  and  $\overline{\text{RAS}}$  cycles.
5. If bus width is programmed as byte or half-word,  $\overline{\text{WBE2:3}}$  represent address bits A30:31 regardless of mux mode.
6.  $\overline{\text{WBE0:1}}$  are always ones during DRAM transfers.

DRAM Read-Write-Read, One Wait

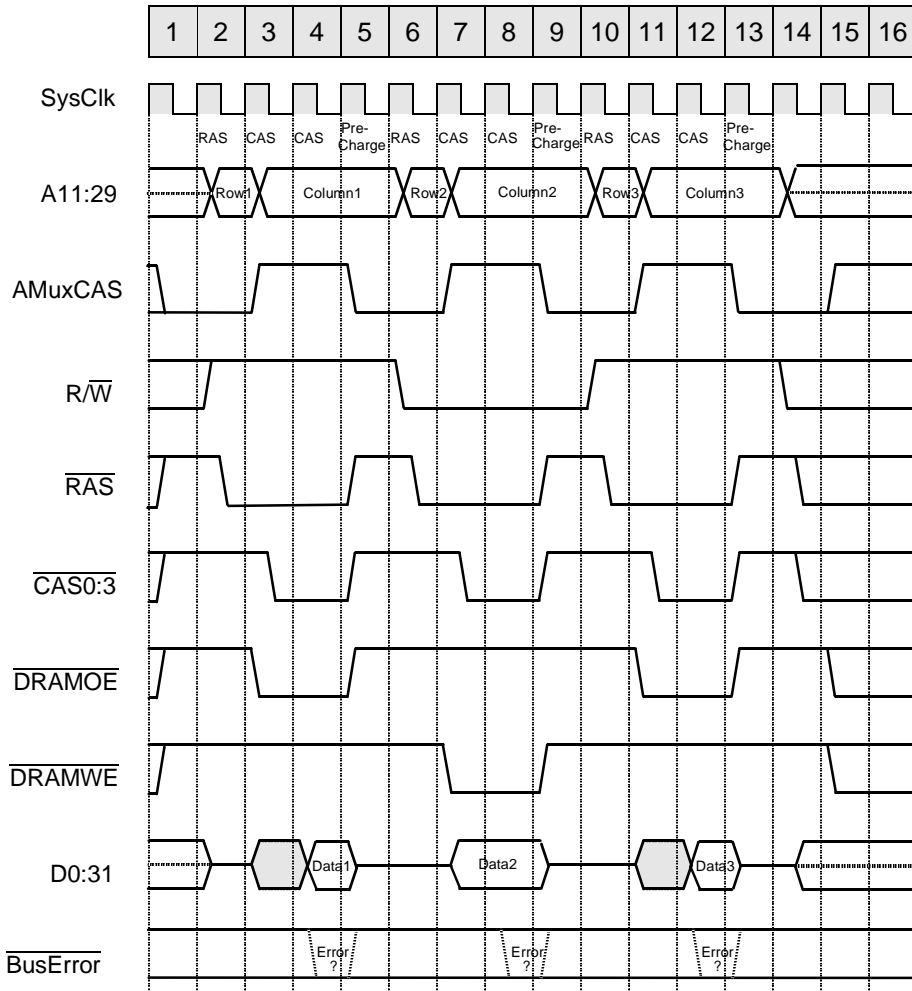

Bank Register Bit Settings

SLF	ERM	Bus Width	Ext Mux	RAS-to-CAS	Refresh Mode	Page Mode	First Access	Burst Access	Prechg Cycles	Refresh RAS	Refresh Rate
Bit 13	Bit 14	Bits 15:16	Bit 17	Bit 18	Bit 19	Bit 20	Bits 21:22	Bits 23:24	Bit 25	Bit 26	Bits 27:30
0 or 1	0	xx	x	0	0	0	01	xx	0	x	xxxx

Notes:

1. If internal mux mode is used, address bits A11:29 represent address bits described in Table 20 on page 32.
2. During internal mux mode access, A6:10 retain their unmuxed values.
3. If external mux mode is used, A11:29 are unaffected and do not change between  $\overline{\text{CAS}}$  and  $\overline{\text{RAS}}$  cycles.
4. If bus width is programmed as byte or half-word,  $\overline{\text{WBE}}2:3$  represent address bits A30:31 regardless of mux mode.
5.  $\overline{\text{WBE}}0:1$  are always ones during DRAM transfers.



### DMA Buffered Single Transfer from Peripheral to 3-Cycle DRAM

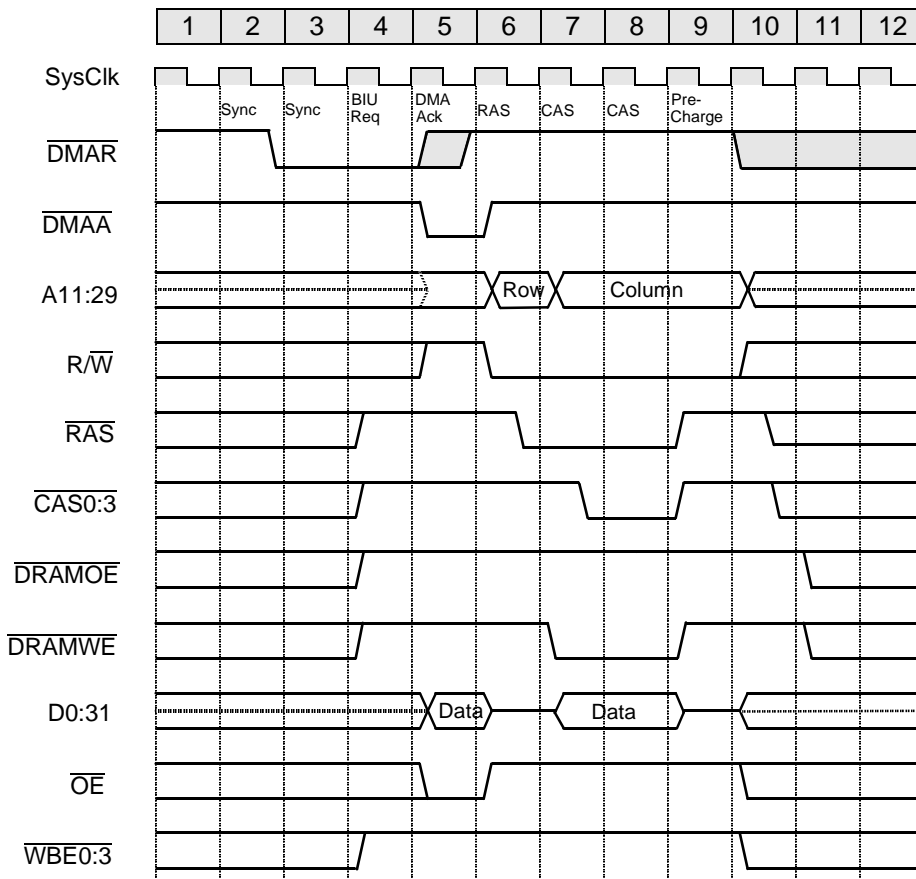

#### Bank Register Bit Settings

SLF	ERM	Bus Width	Ext Mux	RAS-to-CAS	Refresh Mode	Page Mode	First Access	Burst Access	Prechg Cycles	Refresh RAS	Refresh Rate
Bit 13	Bit 14	Bits 15:16	Bit 17	Bit 18	Bit 19	Bit 20	Bits 21:22	Bits 23:24	Bit 25	Bit 26	Bits 27:30
0 or 1	0	10	0	0	0	0	01	xx	0	x	xxxx

#### DMA Control Register Bit Settings

Transfer Direction	Transfer Width	Transfer Mode	Peripheral Setup	Peripheral Wait	Peripheral Hold
Bit 2	Bits 4:5	Bits 9:10	Bits 11:12	Bits 13:18	Bits 19-21
1	10	00	00	00 0000	000

#### Notes:

1. DMAR must be sampled inactive at the start of cycle 9 to guarantee a single transfer.
2. Peripheral data bus width must match DRAM bus width.
3. This waveform assumes that the internal address mux is used.
4. CAS0 is used for byte accesses, CAS0:1 for halfwords, and CAS0:3 for fullwords.

**DMA Fly-By Single Transfer, Write to 3-Cycle DRAM**

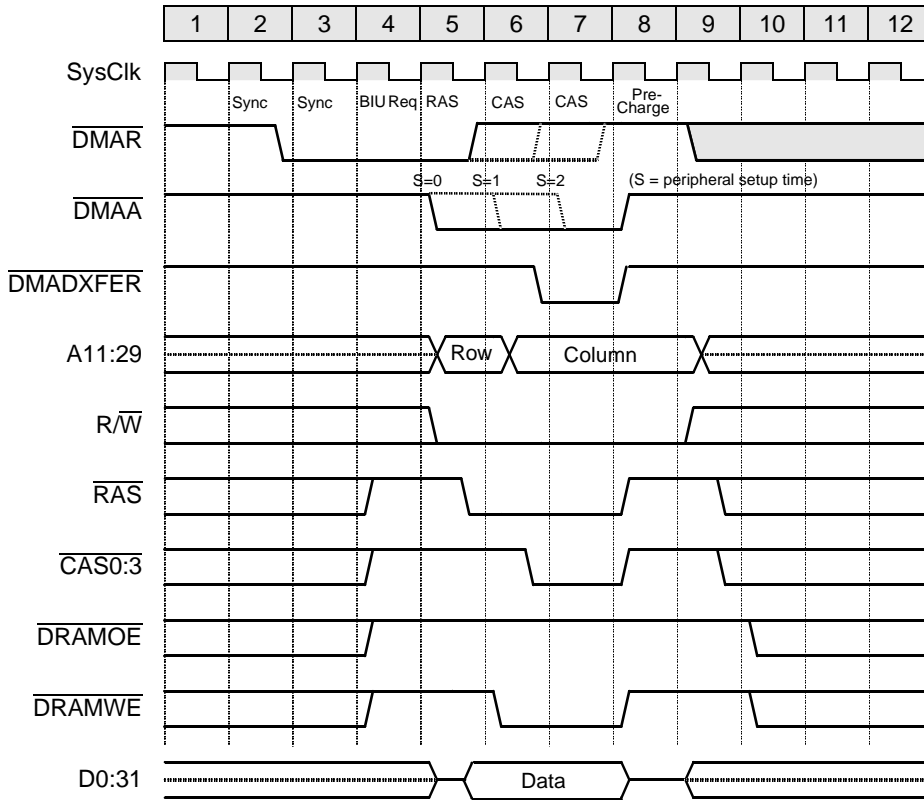

**Bank Register Bit Settings**

SLF	ERM	Bus Width	Ext Mux	RAS-to-CAS	Refresh Mode	Page Mode	First Access	Burst Access	Prechg Cycles	Refresh RAS	Refresh Rate
Bit 13	Bit 14	Bits 15:16	Bit 17	Bit 18	Bit 19	Bit 20	Bits 21:22	Bits 23:24	Bit 25	Bit 26	Bits 27:30
0 or 1	0	10	0	0	0	0	01	xx	0	x	xxxx

**DMA Control Register Bit Settings**

Transfer Direction	Transfer Width	Transfer Mode	Peripheral Setup	Peripheral Wait	Peripheral Hold
Bit 2	Bits 4:5	Bits 9:10	Bits 11:12	Bits 13:18	Bits 19-21
1	10	01	Note 3	xx xxxx	xxx

**Notes:**

1.  $\overline{\text{DMAR}}$  must be inactive in cycle 7 (last  $\overline{\text{DMAA}}$  cycle) to guarantee a single transfer.
2. Peripheral data bus width must match DRAM bus width.
3. See diagram for settings.
4. This waveform assumes that the internal address mux is used.
5.  $\overline{\text{CAS0}}$  is used for byte accesses,  $\overline{\text{CAS0:1}}$  for halfwords, and  $\overline{\text{CAS0:3}}$  for fullwords.

**DMA Fly-By Continuous Burst to 3-Cycle DRAM**

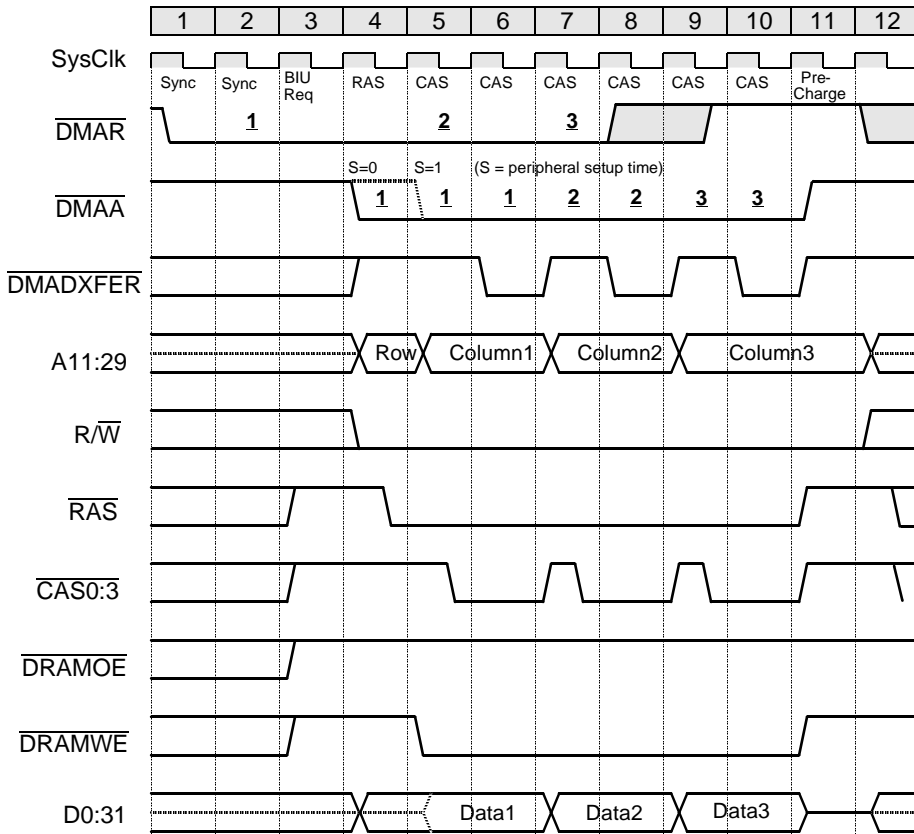

**Bank Register Bit Settings**

SLF	ERM	Bus Width	Ext Mux	RAS-to-CAS	Refresh Mode	Page Mode	First Access	Burst Access	Prechg Cycles	Refresh RAS	Refresh Rate
Bit 13	Bit 14	Bits 15:16	Bit 17	Bit 18	Bit 19	Bit 20	Bits 21:22	Bits 23:24	Bit 25	Bit 26	Bits 27:30
0 or 1	0	10	0	0	0	1	01	01	0	x	xxxx

**DMA Control Register Bit Settings**

Transfer Direction	Transfer Width	Transfer Mode	Peripheral Setup	Peripheral Wait	Peripheral Hold	Burst Mode
Bit 2	Bits 4:5	Bits 9:10	Bits 11:12	Bits 13:18	Bits 19:21	Bit 25
1	10	01	Note 3	xx xxxx	xxx	1

**Notes:**

1.  $\overline{\text{DMAR}}$  must be inactive at the end of cycle 9 to guarantee three transfers.
2. Peripheral data bus width must match DRAM bus width.
3. See diagram for settings.
4. This waveform assumes that the internal address mux is used.
5.  $\overline{\text{CAS0}}$  is used for byte accesses,  $\overline{\text{CAS0:1}}$  for halfwords, and  $\overline{\text{CAS0:3}}$  for fullwords.
6. Numbers (1,2,3,...) in the  $\overline{\text{DMAR}}$  signal represent when  $\overline{\text{DMAR}}$  is sampled and accepted. Numbers (1,2,3,...) in the  $\overline{\text{DMAA}}$  signal represent the transfers associated with the accepted  $\overline{\text{DMAR}}$ .

External Master Nonburst DRAM Read with HoldReq/HoldAck

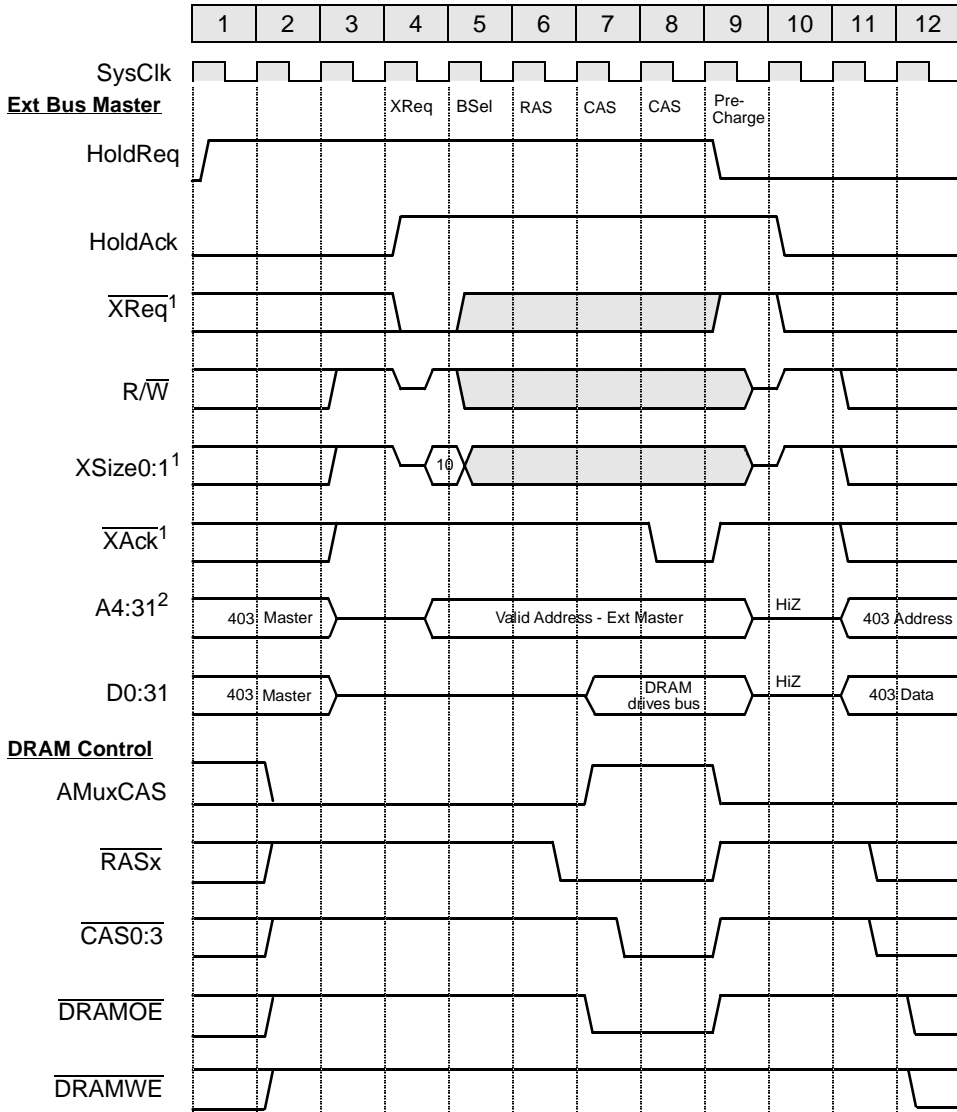

Bank Register Bit Settings

SLF	ERM	Bus Width	Ext Mux	RAS-to-CAS	Refresh Mode	Page Mode	First Access	Burst Access	Prechg Cycles	Refresh RAS	Refresh Rate
Bit 13	Bit 14	Bits 15:16	Bit 17	Bit 18	Bit 19	Bit 20	Bits 21:22	Bits 23:24	Bit 25	Bit 26	Bits 27:30
0 or 1	0	10	1	0	0	0	01	xx	0	x	xxxx

Notes:

- $\overline{XReq}$ ,  $\overline{XSize0}$ ,  $\overline{XSize1}$ , and  $\overline{XAck}$  are multiplexed with  $\overline{DMAR3}$ ,  $\overline{EOT3/TC3}$ ,  $\overline{OE}$ , and  $\overline{DMAA3}$ , respectively.
- A4, A5, A30, and A31 are multiplexed with  $\overline{WBE0}$ ,  $\overline{WBE1}$ ,  $\overline{WBE2}$ , and  $\overline{WBE3}$ , respectively.

### External Master DRAM Burst Write, 3-2-2-2 Page Mode

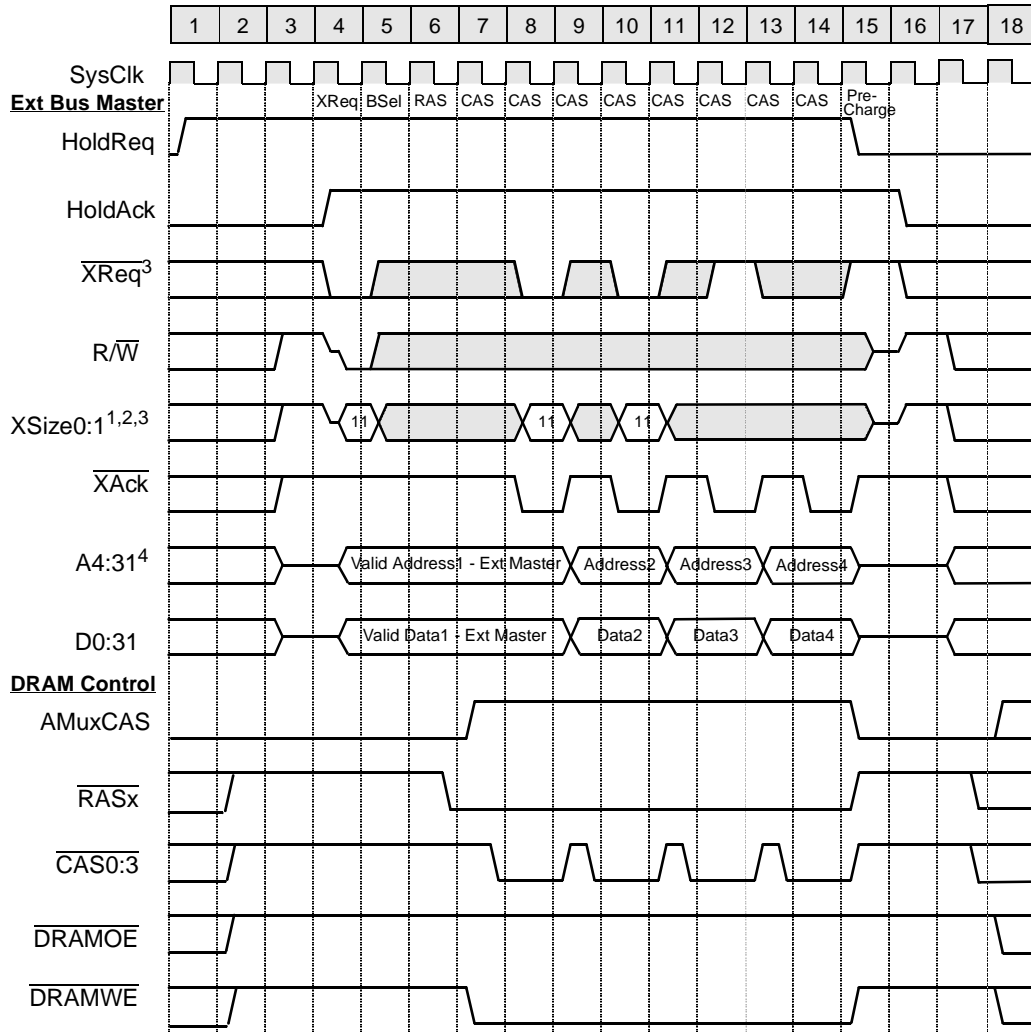

### Bank Register Bit Settings

SLF	ERM	Bus Width	Ext Mux	RAS-to-CAS	Refresh Mode	Page Mode	First Access	Burst Access	Prechg Cycles	Refresh RAS	Refresh Rate
Bit 13	Bit 14	Bits 15:16	Bit 17	Bit 18	Bit 19	Bit 20	Bits 21:22	Bits 23:24	Bit 25	Bit 26	Bits 27:30
0 or 1	0	10	1	0	0	1	01	01	0	x	xxxx

#### Notes:

1. XReq, XSize0, XSize1, and XAck are multiplexed with DMAR3, EOT3/TC3, OE, and DMAA3, respectively.
2. XSize0:1 = 11 indicates a burst transfer at the width of the DRAM device.
3. The burst is terminated in cycle 12 by deasserting the XReq input signal. A burst may also be terminated by deasserting either XSize0 or XSize1.
4. A4, A5, A30, and A31 are multiplexed with WBE0, WBE1, WBE2, and WBE3, respectively.







© Copyright IBM Corporation 1996,1998. All rights reserved.  
Printed in the USA on recycled paper.  
9-98

IBM Microelectronics, PowerPC, PowerPC Architecture, and 403GC are trademarks, IBM and the IBM logo are registered trademarks of IBM Corporation.

This document may contain preliminary information and is subject to change by IBM without notice. IBM assumes no responsibility of liability for any use of the information contained herein. Nothing in this document shall operate as an express or implied license or indemnity under the intellectual property rights of IBM or third parties. The products described in this document are not intended for use in implantation or other direct life support applications where malfunction may result in direct physical harm or injury to persons. NO WARRANTIES OF ANY KIND, INCLUDING BUT NOT LIMITED TO THE IMPLIED WARRANTIES OF MERCHANTABILITY OR FITNESS FOR A PARTICULAR PURPOSE, ARE OFFERED IN THIS DOCUMENT.

IBM Microelectronics Division  
1580 Route 52, Bldg. 502  
Hopewell Junction, NY 12533-6531  
Tel: (800) PowerPC



SC22-9893-04  
09.09.98