

IN74LS164

8-Bit Serial-Input/Parallel-Output Shift Register

This 8-bit shift register features gated serial inputs and an asynchronous reset. The gated serial inputs (A and B) permit complete control over incoming data as a low at either (or both) input(s) inhibits entry of the new data and resets the first flip flop to the low level at the next clock pulse. A high level input enables the other input which will then determine the state of the first flip-flop. Data at the serial inputs may be changed while the clock is high or low, but only information meeting the setup requirements will be entered clocking occurs or the low-to-high level transition of the clock input. All inputs are diode-clamped to minimize transmission-line effects.

- Gated (Enable/Disable) Serial Inputs
- Fully Buffered Clock and Serial Inputs
- Asynchronous Clear

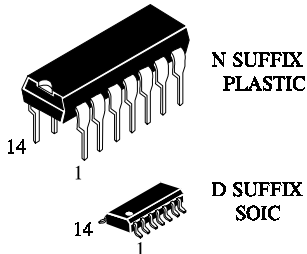

ORDERING INFORMATION
 IN74LS164N Plastic
 IN74LS164D SOIC
 T_A = 0° to 70°C
 for all packages

LOGIC DIAGRAM

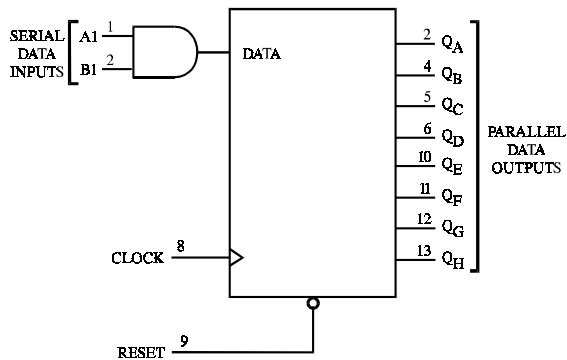

PIN 14 = V_{CC}
 PIN 7 = GND

PIN ASSIGNMENT

A1	1	14	V _{CC}
A2	2	13	Q _H
Q _A	3	12	Q _G
Q _B	4	11	Q _F
Q _C	5	10	Q _E
Q _D	6	9	RESET
GND	7	8	CLOCK

FUNCTION TABLE

Inputs			Outputs			
Reset	Clock	A1 A2	Q _A	Q _B	... Q _n	Q _H
L	X	X X	L	L	... L	
H		X X	no change			
H		H D	D	Q _{An}	... Q _{Gn}	
H		D H	D	Q _{An}	... Q _{Gn}	
H		L L	L	Q _{An}	... Q _{Gn}	

D = data input

X = don't care

Q_{An} - Q_{Gn} = data shifted from the previous stage on a rising edge at the clock input.

IN74LS164

MAXIMUM RATINGS*

Symbol	Parameter	Value	Unit
V _{CC}	Supply Voltage	7.0	V
V _{IN}	Input Voltage	7.0	V
V _{OUT}	Output Voltage	5.5	V
T _{stg}	Storage Temperature Range	-65 to +150	°C

*Maximum Ratings are those values beyond which damage to the device may occur. Functional operation should be restricted to the Recommended Operating Conditions.

RECOMMENDED OPERATING CONDITIONS

Symbol	Parameter	Min	Max	Unit
V _{CC}	Supply Voltage	4.75	5.25	V
V _{IH}	High Level Input Voltage	2.0		V
V _{IL}	Low Level Input Voltage		0.8	V
I _{OH}	High Level Output Current		-0.4	mA
I _{OL}	Low Level Output Current		8.0	mA
T _A	Ambient Temperature Range	0	+70	°C
f _{clock}	Clock Frequency	0	25	MHz
t _{su}	Setup Time, A1 or A2 to Clock	15		ns
t _h	Hold Time, Clock to A1 or A2	5		ns
t _w	Pulse Width, Clock	20		ns
t _w	Pulse Width, Reset	20		ns
t _{rec}	Recovery Time	5		ns

DC ELECTRICAL CHARACTERISTICS over full operating conditions

Symbol	Parameter	Test Conditions	Guaranteed Limit		Unit
			Min	Max	
V _{IK}	Input Clamp Voltage	V _{CC} = min, I _{IN} = -18 mA		-1.5	V
V _{OH}	High Level Output Voltage	V _{CC} = min, I _{OH} = -0.4 mA	2.7		V
V _{OL}	Low Level Output Voltage	V _{CC} = min, I _{OL} = 4 mA		0.4	V
		V _{CC} = min, I _{OL} = 8 mA		0.5	
I _{IH}	High Level Input Current	V _{CC} = max, V _{IN} = 2.7 V		20	mA
		V _{CC} = max, V _{IN} = 7.0 V		0.1	mA
I _{IL}	Low Level Input Current	V _{CC} = max, V _{IN} = 0.4 V		-0.4	mA
I _O	Output Short Circuit Current	V _{CC} = max, V _O = 0 V (Note 1)	-20	-100	mA
I _{CC}	Supply Current	V _{CC} = max (Note 2)		27	mA

Note 1: Not more than one output should be shorted at a time, and duration should not exceed one second.

Note 2: I_{CC} is measured with outputs open, serial inputs grounded, the clock input at 2.4 V, and a momentary ground, then 4.5 V applied.

AC ELECTRICAL CHARACTERISTICS ($T_A=25^\circ\text{C}$, $V_{CC} = 5.0\text{ V}$, $C_L = 15\text{ pF}$, $R_L = 2\text{ k}\Omega$, $t_r = 15\text{ ns}$, $t_f = 6.0\text{ ns}$)

Symbol	Parameter	Min	Max	Unit
t_{PLH}	Propagation Delay Time, Clock to Q		27	ns
t_{PHL}	Propagation Delay Time, Clock to Q		32	ns
t_{PHL}	Propagation Delay Time, Reset to Q		36	ns
t_{su}	Setup Time, A1 or A2 to Clock	15		ns
t_h	Hold Time, Clock to A1 or A2	5		ns
t_w	Pulse Width, Clock	20		ns
t_w	Pulse Width, Reset	20		ns

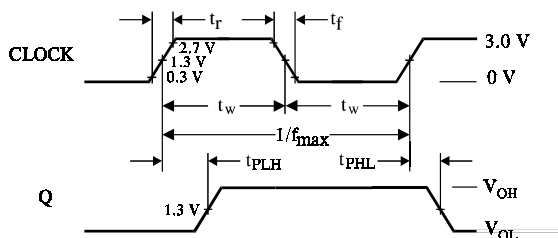

Figure 1. Switching Waveforms

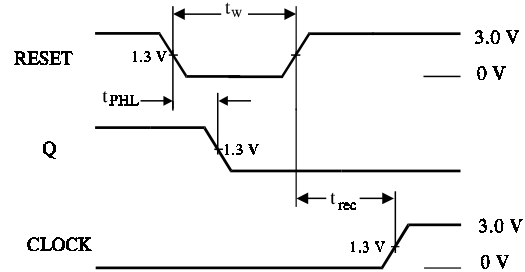

Figure 2. Switching Waveforms

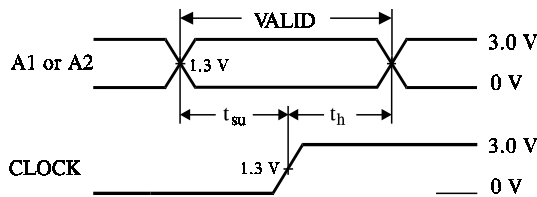
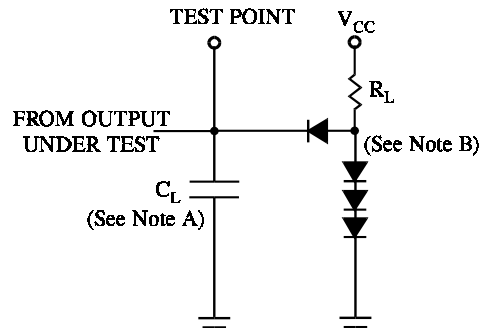

Figure 3. Switching Waveform



NOTES A. C_L includes probe and jig capacitance.
 B. All diodes are 1N916 or 1N3064.

Figure 4. Test Circuit

TIMING DIAGRAM

