



**10/100BASE Local CPU Bus Fast Ethernet MAC Controller
with Embedded SRAM, SNI interface and Parallel Port**

Document No.: AX196-12 / V1.2 / May. 12 '00

Features

- IEEE 802.3u 100BASE-T, TX, and T4 Compatible
- Single chip local CPU bus 10/100Mbps Fast Ethernet MAC Controller
- Embedded 8K * 16 bit SRAM
- NE2000 register level compatible instruction
- Support both 8 bit and 16 bit local CPU interfaces include MCS-51 series, 80186 series and MC68K series CPU
- Support both 10Mbps and 100Mbps data rate
- Support both full-duplex or half-duplex operation
- Provides a MII port for both 10/100Mbps operation
- Provides SNI I/F for Home LAN PHY or 10M transceiver option
- Support EEPROM interface to store MAC address
- External and internal loop-back capability
- Support Standard Print Port, can also used as general I/O port
- 128-pin LQFP low profile package
- 20MHz to 25MHz Operation, Dual 5V and 3.3V CMOS process with 5V I/O tolerance. Or pure 3.3V operation

*IEEE is a registered trademark of the Institute of Electrical and Electronic Engineers, Inc.

*All other trademarks and registered trademark are the property of their respective holders.

Product description

The AX88196 Fast Ethernet Controller is a high performance and highly integrated local CPU bus Ethernet Controller with embedded 8K*16 bit SRAM. The AX88196 supports both 8 bit and 16 bit local CPU interfaces include MCS-51 series, 80186 series, MC68K series CPU and ISA bus. The AX88196 implements both 10Mbps and 100Mbps Ethernet function based on IEEE802.3 / IEEE802.3u LAN standard and supports both 10Mbps/100Mbps media-independent interface (MII) and legacy pure 10Mbps SNI interface to simplify the design. Using Serial Network Interface (SNI) transceiver, Home LAN PHY or 10BASE-2 BNC type media can be supported.

As well as, the chip also provides Standard Print Port (parallel port interface), can be used for printer server device or treat as simple general I/O port.

System Block Diagram

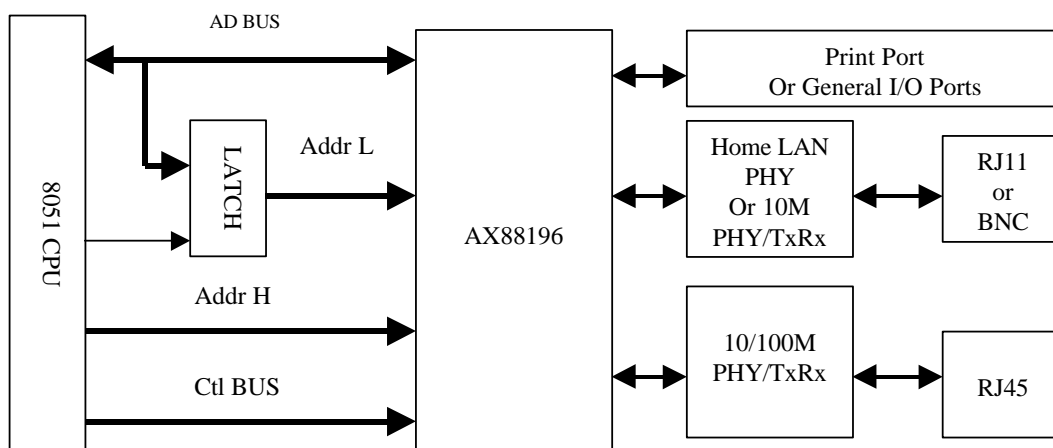

Always contact ASIX for possible updates before starting a design.

This data sheet contains new products information. ASIX ELECTRONICS reserves the rights to modify product specification without notice. No liability is assumed as a result of the use of this product. No rights under any patent accompany the sale of the product.

ASIX ELECTRONICS CORPORATION

2F, NO.13, Industry East Rd. II, Science-based Industrial Park, Hsin-Chu City, Taiwan, R.O.C.
TEL: 886-3-579-9500

First Released Date : Dec/13/1999

FAX: 886-3-579-9558

http://www.asix.com.tw



CONTENTS

1.0 INTRODUCTION4

1.1 GENERAL DESCRIPTION:4

1.2 AX88196 BLOCK DIAGRAM:.....4

1.3 AX88196 PIN CONNECTION DIAGRAM5

 1.3.1 AX88196 Pin Connection Diagram for ISA Bus Mode.....6

 1.3.2 AX88196 Pin Connection Diagram for 80x86 Mode.....7

 1.3.3 AX88196 Pin Connection Diagram for MC68K Mode.....8

 1.3.4 AX88196 Pin Connection Diagram for MCS-51 Mode9

2.0 SIGNAL DESCRIPTION.....10

2.1 LOCAL CPU BUS INTERFACE SIGNALS GROUP.....10

2.2 MII INTERFACE SIGNALS GROUP11

2.3 EEPROM SIGNALS GROUP12

2.4 SNI INTERFACE PINS GROUP12

2.5 STANDARD PRINTER PORT INTERFACE PINS GROUP12

2.6 POWER ON CONFIGURATION SETUP SIGNALS PINS GROUP13

2.7 MISCELLANEOUS PINS GROUP13

3.0 MEMORY AND I/O MAPPING15

3.1 EEPROM MEMORY MAPPING15

3.2 I/O MAPPING.....15

3.3 SRAM MEMORY MAPPING15

4.0 REGISTERS OPERATION.....16

4.1 COMMAND REGISTER (CR) OFFSET 00H (READ/WRITE)18

4.2 INTERRUPT STATUS REGISTER (ISR) OFFSET 07H (READ/WRITE).....18

4.3 INTERRUPT MASK REGISTER (IMR) OFFSET 0FH (WRITE).....19

4.4 DATA CONFIGURATION REGISTER (DCR) OFFSET 0EH (WRITE).....19

4.5 TRANSMIT CONFIGURATION REGISTER (TCR) OFFSET 0DH (WRITE).....19

4.6 TRANSMIT STATUS REGISTER (TSR) OFFSET 04H (READ).....20

4.7 RECEIVE CONFIGURATION (RCR) OFFSET 0CH (WRITE).....20

4.8 RECEIVE STATUS REGISTER (RSR) OFFSET 0CH (READ)20

4.9 INTER-FRAME GAP (IFG) OFFSET 16H (READ/WRITE)21

4.10 INTER-FRAME GAP SEGMENT 1(IFGS1) OFFSET 12H (READ/WRITE).....21

4.11 INTER-FRAME GAP SEGMENT 2(IFGS2) OFFSET 13H (READ/WRITE).....21

4.12 MII/EEPROM MANAGEMENT REGISTER (MEMR) OFFSET 14H (READ/WRITE).....21

4.13 TEST REGISTER (TR) OFFSET 15H (WRITE).....21

4.14 SPP DATA PORT REGISTER (SPP_DPR) OFFSET 18H (READ/WRITE).....22

4.15 SPP STATUS PORT REGISTER (SPP_SPR) OFFSET 19H (READ).....22

4.16 SPP COMMAND PORT REGISTER (SPP_CPR) OFFSET 1AH (READ/WRITE)22

5.0 CPU I/O READ AND WRITE FUNCTIONS.....23

5.1 ISA BUS TYPE ACCESS FUNCTIONS.23

5.2 80186 CPU BUS TYPE ACCESS FUNCTIONS.23

5.3 MC68K CPU BUS TYPE ACCESS FUNCTIONS.....24

5.4 MCS-51 CPU BUS TYPE ACCESS FUNCTIONS.24

6.0 ELECTRICAL SPECIFICATION AND TIMINGS25

6.1 ABSOLUTE MAXIMUM RATINGS.....25

6.2 GENERAL OPERATION CONDITIONS25

6.3 DC CHARACTERISTICS.....25

6.4 A.C. TIMING CHARACTERISTICS.....26

 6.4.1 XTAL / CLOCK.....26



6.4.2 Reset Timing.....	26
6.4.3 ISA Bus Access Timing.....	27
6.4.4 80186 Type I/O Access Timing.....	28
6.4.5 68K Type I/O Access Timing.....	29
6.4.6 8051 Bus Access Timing.....	30
6.4.7 MII Timing.....	31
6.4.8 SNI Timing.....	32
7.0 PACKAGE INFORMATION	33
APPENDIX A: APPLICATION NOTE.....	34
A.1 USING CRYSTAL 25MHZ OR 20MHZ.....	34
A.2 USING OSCILLATOR 25MHZ OR 20MHZ.....	34
A.3 USING 60MHZ OSCILLATOR/CRYSTAL.....	34
A.4 DUAL POWER (5V AND 3.3V/3.0V) APPLICATION	35
A.5 SINGLE POWER (3.3V/3.0V) APPLICATION.....	35
A.6 DUAL POWER (5V AND 3.3V) APPLICATION WITH 3.3V PHY	36
ERRATA OF AX88196 VERSION ED2.....	37
DEMONSTRATION CIRCUIT : AX88196 + ETHERNET PHY + HOMEPNA 1M8 PHY	38

FIGURES

FIG - 1 AX88196 BLOCK DIAGRAM.....	4
FIG - 2 AX88196 PIN CONNECTION DIAGRAM.....	5
FIG - 3 AX88196 PIN CONNECTION DIAGRAM FOR ISA BUS MODE.....	6
FIG - 4 AX88196 PIN CONNECTION DIAGRAM FOR 80x86 MODE.....	7
FIG - 5 AX88196 PIN CONNECTION DIAGRAM FOR MC68K MODE.....	8
FIG - 6 AX88196 PIN CONNECTION DIAGRAM FOR MCS-51 MODE.....	9

TABLES

TAB - 1 LOCAL CPU BUS INTERFACE SIGNALS GROUP.....	11
TAB - 2 MII INTERFACE SIGNALS GROUP.....	11
TAB - 3 EEPROM BUS INTERFACE SIGNALS GROUP.....	12
TAB - 4 SERIAL NETWORK INTERFACE PINS GROUP	12
TAB - 5 STANDARD PRINTER PORT INTERFACE PINS GROUP	13
TAB - 6 POWER ON CONFIGURATION SETUP PINS GROUP	13
TAB - 7 MISCELLANEOUS PINS GROUP.....	14
TAB - 8 I/O ADDRESS MAPPING.....	15
TAB - 9 LOCAL MEMORY MAPPING.....	15
TAB - 10 PAGE 0 OF MAC CORE REGISTERS MAPPING.....	16
TAB - 11 PAGE 1 OF MAC CORE REGISTERS MAPPING.....	17



1.0 Introduction

1.1 General Description:

The AX88196 provides industrial standard NE2000 registers level compatible instruction set. Various drivers are easy acquired, maintenance and usage. No much additional effort to be paid. Software is easily port to various embedded system with no pain and tears

The AX88196 Fast Ethernet Controller is a high performance and highly integrated local CPU bus Ethernet Controller with embedded 8K*16 bit SRAM. The AX88196 supports both 8 bit and 16 bit local CPU interfaces include MCS-51 series, 80186 series, MC68K series CPU and ISA bus. The AX88196 implements both 10Mbps and 100Mbps Ethernet function based on IEEE802.3 / IEEE802.3u LAN standard and supports both 10Mbps/100Mbps media-independent interface (MII) and legacy pure 10Mbps SNI interface to simplify the design. Using Serial Network Interface (SNI) transceiver, Home LAN PHY or 10BASE-2 BNC type media can be supported.

As well as, the chip also provides Standard Print Port (parallel port interface), can be used for printer server device or treat as simple general I/O port.

The main difference between AX88196 and AX88195 are : 1) Replace memory I/F with SNI and SPP I/F. 2) Canceling SAX address decoding. 3) Fix interrupt status can't always clean up problem of AX88195.

AX88196 use 128-pin LQFP low profile package, 25MHz operation, dual 5V and 3.3V CMOS process with 5V I/O tolerance or pure 3.3V operation.

1.2 AX88196 Block Diagram:

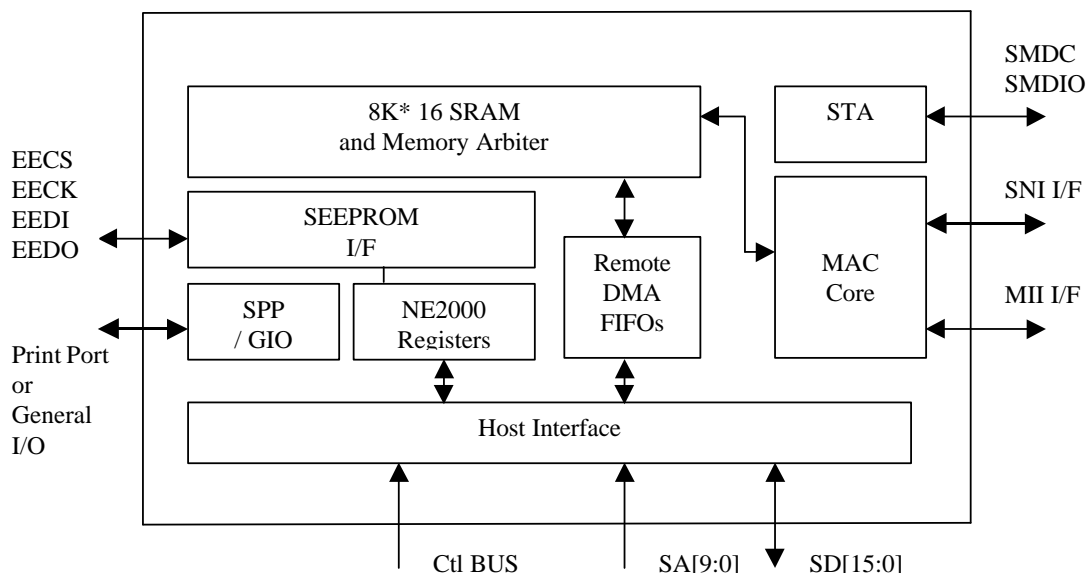

Fig - 1 AX88196 Block Diagram



1.3 AX88196 Pin Connection Diagram

The AX88196 is housed in the 128-pin plastic light quad flat pack. Fig - 2 AX88196 Pin Connection Diagram shows the AX88196 pin connection diagram.

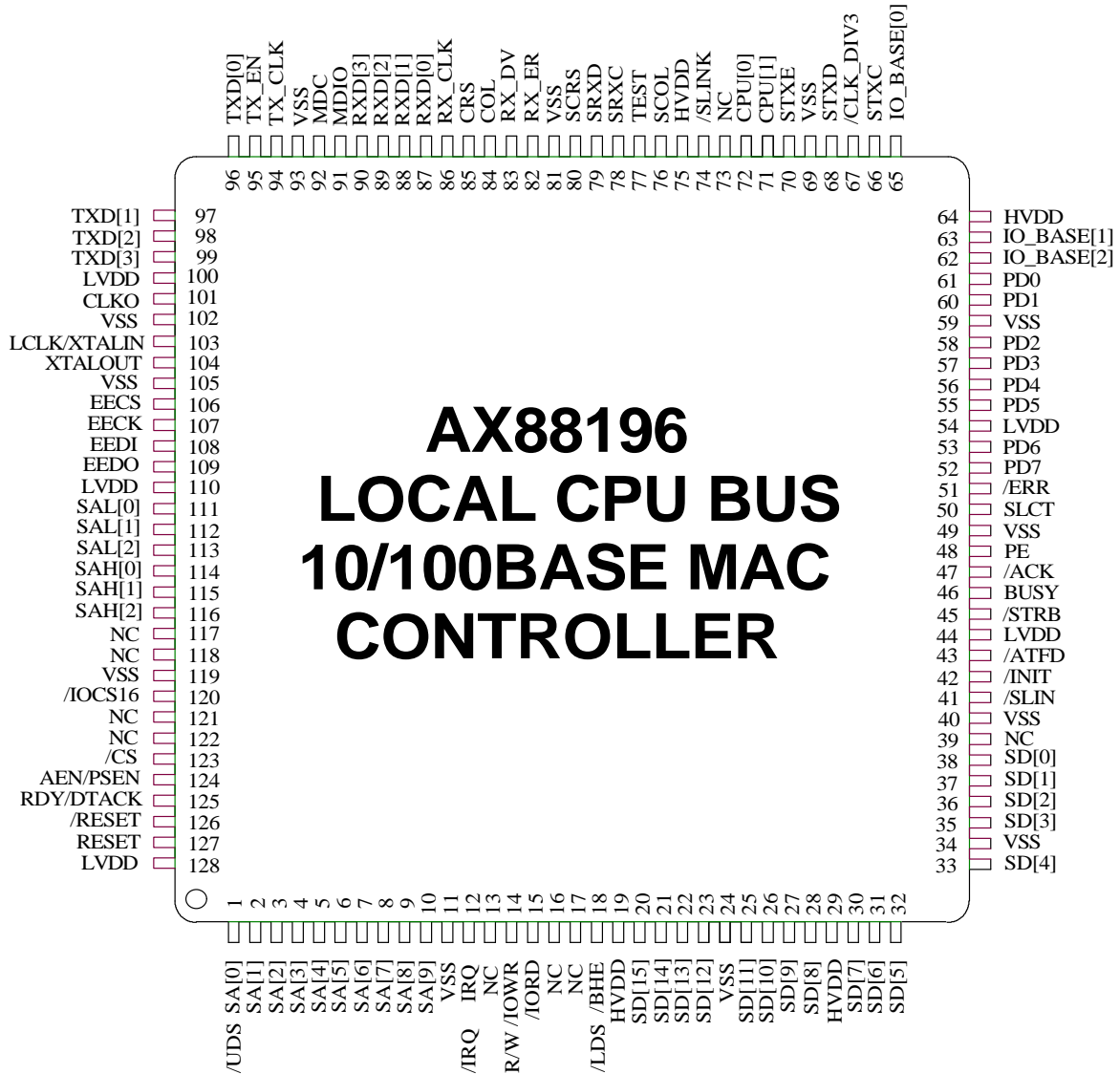

Fig - 2 AX88196 Pin Connection Diagram



1.3.1 AX88196 Pin Connection Diagram for ISA Bus Mode

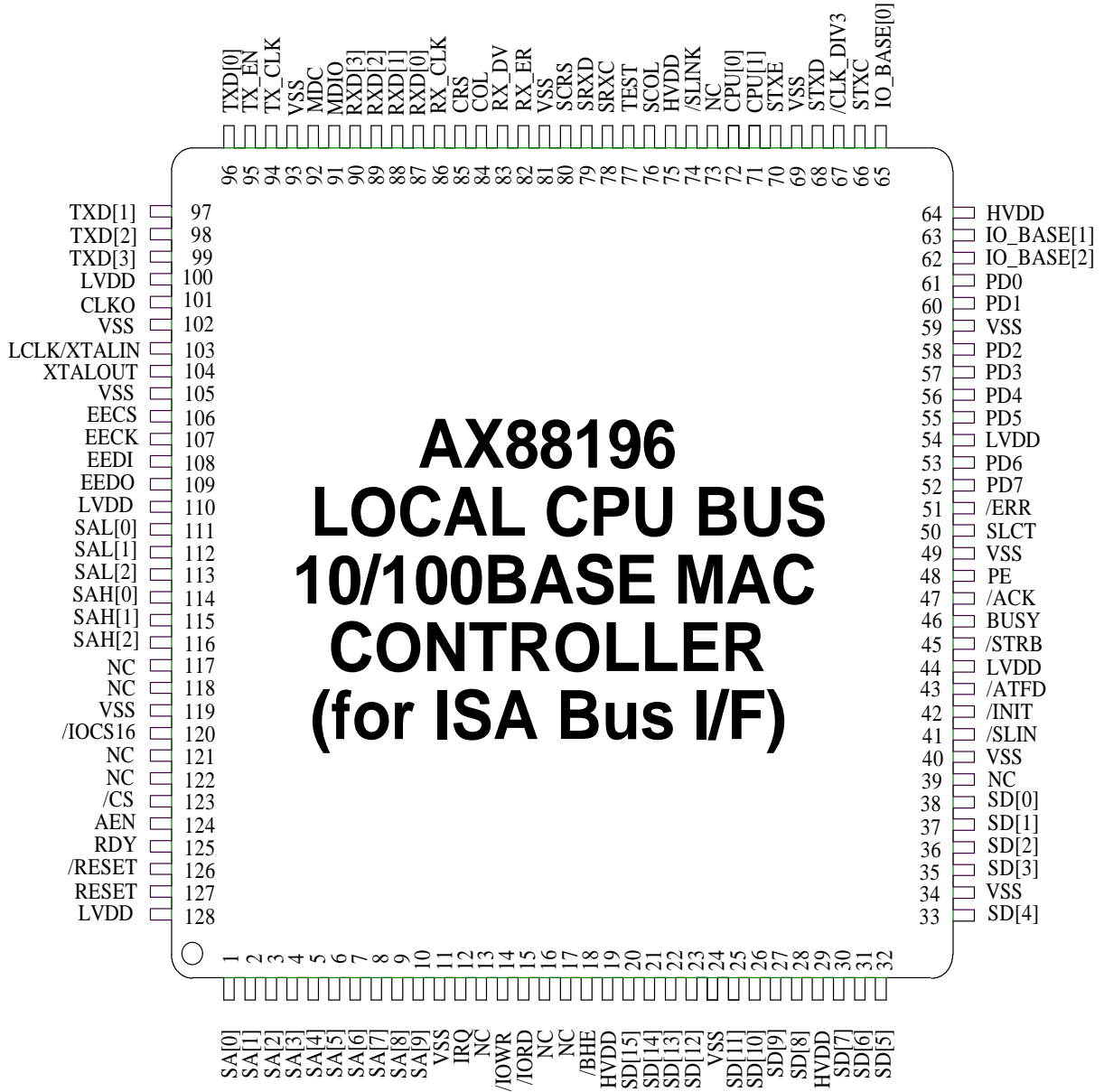

Fig - 3 AX88196 Pin Connection Diagram for ISA Bus Mode



1.3.2 AX88196 Pin Connection Diagram for 80x86 Mode

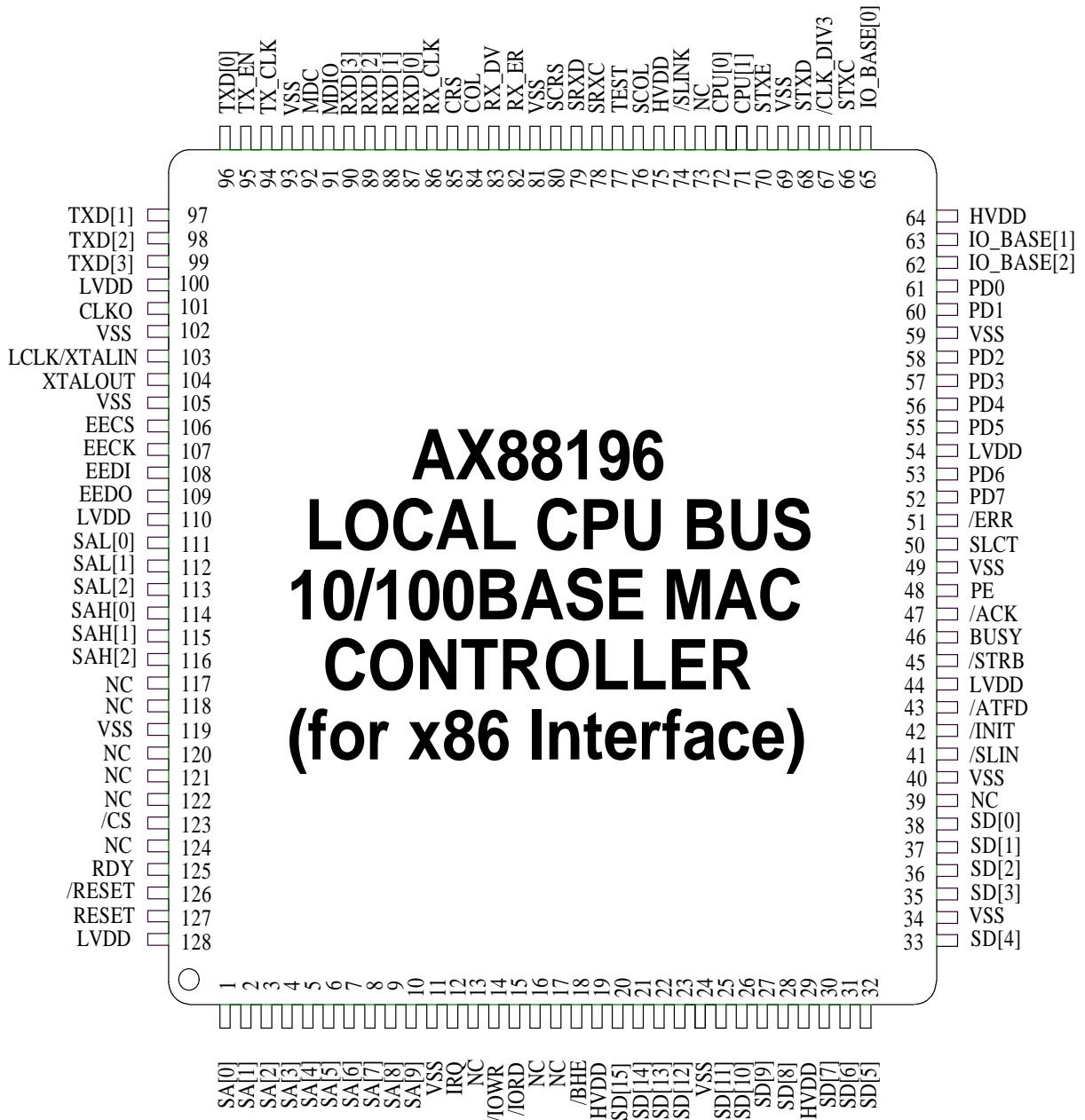

Fig - 4 AX88196 Pin Connection Diagram for 80x86 Mode



1.3.3 AX88196 Pin Connection Diagram for MC68K Mode

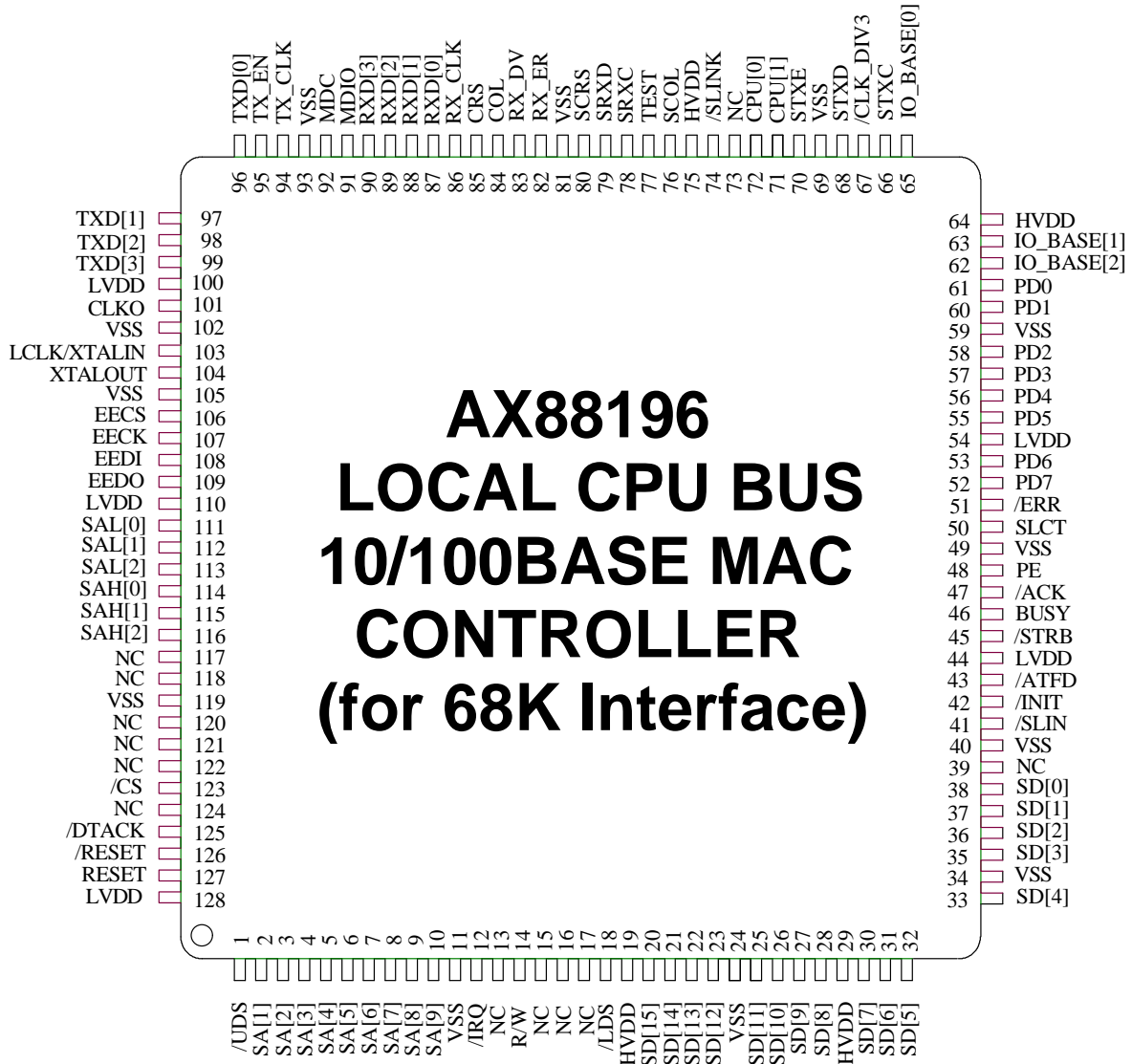

Fig - 5 AX88196 Pin Connection Diagram for MC68K Mode



1.3.4 AX88196 Pin Connection Diagram for MCS-51 Mode

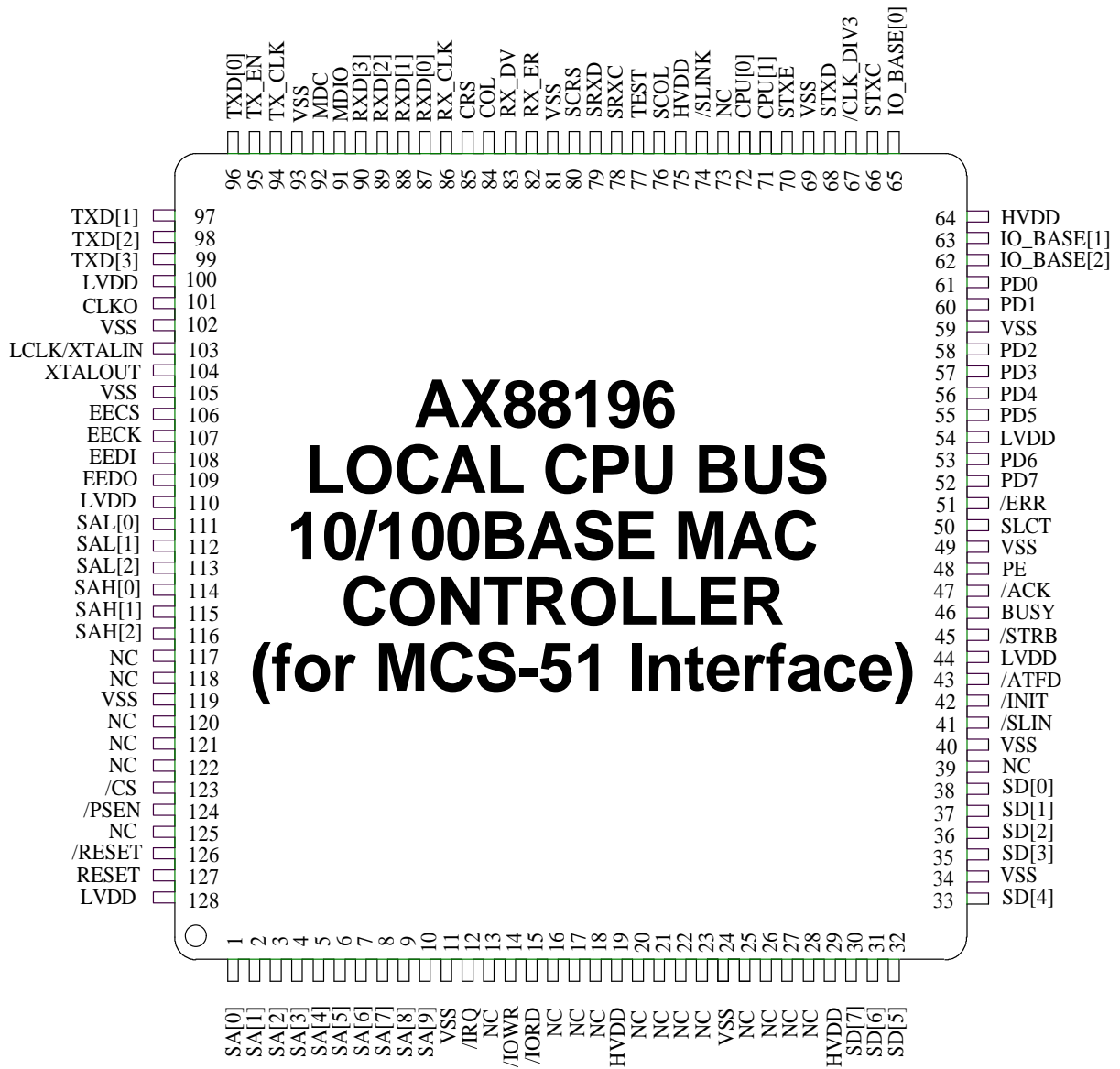

Fig - 6 AX88196 Pin Connection Diagram for MCS-51 Mode



2.0 Signal Description

The following terms describe the AX88196 pin-out:

All pin names with the “/” suffix are asserted low.

The following abbreviations are used in following Tables.

I	Input	PU	Pull Up
O	Output	PD	Pull Down
I/O	Input/Output	P	Power Pin
OD	Open Drain		

2.1 Local CPU Bus Interface Signals Group

SIGNAL	TYPE	PIN NO.	DESCRIPTION
SAL[2:0]	I/PD	113 – 111	System Address Select Low : Signals SAL[2:0] are additional address signal input lines which active low enable higher I/O address decoder on chip.
SAH[2:0]	I/PU	116 – 114	System Address Select High : Signals SAH[2:0] are additional address signal input lines which active high enable higher I/O address decoder on chip.
SA[9:1], SA[0]/UDS	I	10 – 1	System Address : Signals SA[9:0] are address bus input lines which lower I/O spaces on chip. SA[0] also means Upper Data Strobe (/UDS) active low signal in 68K application mode
/BHE or /LDS	I	18	Bus High Enable or Lower Data Strobe : Bus High Enable is active low signal in some 16 bit application mode which enable high bus (SD[15:8]) active. The signal also name as Lower Data Strobe (LDS) for 68K application mode.
SD[15:0]	I/O	20 – 23, 25 – 28, 30 – 33, 35 – 38	System Data Bus : Signals SD[15:0] constitute the bi-directional data bus.
IREQ/IREQ	O	12	Interrupt Request : When ISA BUS or 80186 CPU mode is select. IREQ is asserted high to indicate the host system that the chip requires host software service. When MC68K or MCS-51 CPU mode is select. /IREQ is asserted low to indicate the host system that the chip requires host software service.
RDY/DTACK	OD	125	Ready : This signal is set low to insert wait states during Remote DMA transfer. /Dtack : When Motorola CPU type is select, the pin is active low inform CPU that data is accepted.
/CS	I	123	Chip Select When the /CS signal is asserted, the chip is selected.
/IORD	I	15	I/O Read :The host asserts /IORD to read data from AX88196 I/O space. When Motorola CPU type is select , the pin is useless.
/IOWR or R/W	I	14	I/O Write :The host asserts /IOWR to write data into AX88196 I/O space. When Motorola CPU type is select, the pin is active high for read operation at the same time.
/OCS16	OD	120	I/O is 16 Bit Port : The /IOIS16 is asserted when the address at the range corresponds to an I/O address to which the chip responds, and the I/O port addressed is capable of 16-bit access.



AEN or /PSEN	I/PD	124	Address Enable : The signal is asserted when the address bus is available for DMA cycle. When negated (low), AX88196 an I/O slave device may respond to addresses and I/O command. PSEN : This signal is active low for 8051 program access. For I/O device, AX88196, this signal is active high to access the chip. This signal is for 8051 bus application only.
--------------------	------	-----	---

Tab - 1 Local CPU bus interface signals group

2.2 MII interface signals group

SIGNAL	TYPE	PIN NO.	DESCRIPTION
RXD[3:0]	I	90 – 87	Receive Data : RXD[3:0] is driven by the PHY synchronously with respect to RX_CLK.
CRS	I	85	Carrier Sense : Asynchronous signal CRS is asserted by the PHY when either the transmit or receive medium is non-idle.
RX_DV	I	83	Receive Data Valid : RX_DV is driven by the PHY synchronously with respect to RX_CLK. Asserted high when valid data is present on RXD [3:0].
RX_ER	I	82	Receive Error : RX_ER ,is driven by PHY and synchronous to RX_CLK, is asserted for one or more RX_CLK periods to indicate to the port that an error has detected.
RX_CLK	I	86	Receive Clock : RX_CLK is a continuous clock that provides the timing reference for the transfer of the RX_DV,RXD[3:0] and RX_ER signals from the PHY to the MII port of the repeater.
COL	I	84	Collision : this signal is driven by PHY when collision is detected.
TX_EN	O	95	Transmit Enable : TX_EN is transition synchronously with respect to the rising edge of TX_CLK. TX_EN indicates that the port is presenting nibbles on TXD [3:0] for transmission.
TXD[3:0]	O	99 – 96	Transmit Data : TXD[3:0] is transition synchronously with respect to the rising edge of TX_CLK. For each TX_CLK period in which TX_EN is asserted, TXD[3:0] are accepted for transmission by the PHY.
TX_CLK	I	94	Transmit Clock : TX_CLK is a continuous clock from PHY. It provides the timing reference for the transfer of the TX_EN and TXD[3:0] signals from the MII port to the PHY.
MDC	O	92	Station Management Data Clock : The timing reference for MDIO. All data transfers on MDIO are synchronized to the rising edge of this clock. MDC is a 2.5MHz frequency clock output.
MDIO	I/O/PU	91	Station Management Data Input / Output : Serial data input/output transfers from/to the PHYs . The transfer protocol conforms to the IEEE 802.3u MII specification.

Tab - 2 MII interface signals group



2.3 EEPROM Signals Group

SIGNAL	TYPE	PIN NO.	DESCRIPTION
EECS	O	106	EEPROM Chip Select : EEPROM chip select signal.
EECK	O	107	EEPROM Clock : Signal connected to EEPROM clock pin.
EEDI	O	108	EEPROM Data In : Signal connected to EEPROM data input pin.
EEDO	I/PU	109	EEPROM Data Out : Signal connected to EEPROM data output pin.

Tab - 3 EEPROM bus interface signals group

2.4 SNI Interface pins group

SIGNAL	TYPE	PIN NO.	DESCRIPTION
STXC	I	66	Transmit Clock : this signal is driven by PHY with 20MHz clock.
STXD	O	68	Transmit Data : STXD is transition synchronously with respect to the rising edge of STXC. For each STXC period in which STXE is asserted, STXD is accepted for transmission by the PHY.
STXE	O	70	Transmit Enable : STXE is transition synchronously with respect to the rising edge of STXC. STXE indicates that the port is presenting data on STXD for transmission.
SCOL	I	76	Collision : this signal is driven by PHY when collision is detected.
SRXC	I	78	Receive Clock : SRXC is driven by PHY for received data synchronization.
SRXD	I	79	Receive Data : SRXD is driven by the PHY synchronously with respect to SRXC.
SCRS	I	80	Carrier Sense : Asynchronous signal SCRS is asserted by the PHY when either the transmit or receive medium is non-idle.
/SLINK	I/PU	74	Link indicator : Active low indicate the SNI interface is link to network. When SNI is not used must keep the pin no connection or pull high the signal.

Tab - 4 Serial Network Interface pins group

2.5 Standard Printer Port Interface pins group

SIGNAL	TYPE	PIN NO.	DESCRIPTION
PD[7:0]	I/O/PU	52, 53 55-58 60, 61	Parallel Data :The bi-directional parallel data bus is used to transfer information between CPU and peripherals. Default serve as input, using /DOE bit of register offset x1Ah to set the direction.
BUSY	I	46	Busy : This is a status input from the printer, high indicating that the printer is not ready to receive new data.
/ACK	I	47	Acknowledge : A low active input from the printer indicating that it has received the data and is ready to accept new data.
PE	I	48	Paper Empty : A status input from the printer, high indicating that the printer is out of paper.
SLCT	I	50	Slect : This high active input from the printer indicating that it has power on.
/ERR	I	51	Error : A low active input from the printer indicating that there is an error condition at the printer.
/SLCTIN	O	41	Slect In : This active low output selects the printer.
/INIT	O	42	Init : This signal is used to initiate the printer when low.
/ATFD	O	43	Auto Feed :This output goes low to cause the printer to automatically



			feed one line after each line is printed.
/STRB	O	45	Strobe : A low active pulse on this output is used to strobe the print data into the printer.

Tab - 5 Standard Printer Port Interface pins group

2.6 Power on configuration setup signals pins group

SIGNAL	TYPE	PIN NO.	DESCRIPTION			
IO_BASE[2:0]	I/PU	62, 63,65	IO_BASE[2]	IO_BASE[1]	IO_BASE[0]	IO_BASE
			0	0	0	300h
			0	0	1	320h
			0	1	0	340h
			0	1	1	360h
			1	0	0	380h
			1	0	1	3A0h
			1	1	0	200h
CPU[1:0]	I/PU	71, 72	CPU[1]	CPU[0]	CPU TYPE	
			0	0	ISA BUS	
			0	1	80186	
			1	0	MC68K	
			1	1	MCS-51 (805X)	

Tab - 6 Power on configuration setup pins group

2.7 Miscellaneous pins group

SIGNAL	TYPE	PIN NO.	DESCRIPTION
LCLK/XTALIN	I	103	CMOS Local Clock : A 25Mhz clock, +/- 100 ppm, 40%-60% duty cycle. Crystal Oscillator Input : A 25Mhz crystal, +/- 25 ppm can be connected across XTALIN and XTALOUT.
XTALOUT	O	104	Crystal Oscillator Output : A 25Mhz crystal, +/- 25 ppm can be connected across XTALIN and XTALOUT. If a single-ended external clock (LCLK) is connected to XTALIN, the crystal output pin should be left floating.
CLKO	O	101	Clock Output : This clock is source from LCLK/XTALIN.
/CLK_DIV3	I/PU	67	Clock Divide 3 Enable : Active low to enable the divided 3 circuit. That internally divides LCLK/XTALIN input frequency by 3 and then feed into internal circuit for system clock used. Default value set to logic high, this function is disabled.
RESET	I/PD	127	Reset : Reset is active high then place AX88196 into reset mode immediately. During Falling edge the AX88196 loads the power on setting data. User can select either RESET or /RESET for applications.
/RESET	I/PU	126	/Reset : Reset is active low then place AX88196 into reset mode immediately. During rising edge the AX88196 loads the power on setting data. User can select either RESET or /RESET for applications.
/TEST	I/PU	77	Test Pin : Active LOW The pin is just for test mode setting purpose only. Must be pull high when normal operation.
NC	N/A	13, 16, 17, 39, 73, 117,	No Connection : for manufacturing test only.



AX88196

Local CPU BUS MAC Controller

		118, 121, 122	
LVDD	P	44, 54, 100, 110, 128	Power Supply : +3.3V DC.
HVDD	P	19, 29, 64, 75	Power Supply : +5V DC. Note : for pure 3.3V single power solution, all the HVDD pin can connect to +3.3V. Care should be taken that HVDD input power must be greater or equal (\geq) than LVDD.
VSS	P	11, 24, 34, 40, 49, 59, 69, 81, 93, 102, 105, 119	Power Supply : +0V DC or Ground Power.

Tab - 7 Miscellaneous pins group



3.0 Memory and I/O Mapping

There are four memory or I/O mapping used in AX88196.

1. EEPROM Memory Mapping
2. I/O Mapping
3. Local Memory Mapping

3.1 EEPROM Memory Mapping

User can define by themselves and can access via I/O address offset 14H MII/EEPROM registers

3.2 I/O Mapping

SYSTEM I/O OFFSET	FUNCTION
0000H 001FH	MAC CORE REGISTER

Tab - 8 I/O Address Mapping

3.3 SRAM Memory Mapping

OFFSET	FUNCTION
4000H 7FFF	NE2000 COMPATABLE MODE 8K X 16 SRAM BUFFER

Tab - 9 Local Memory Mapping



4.0 Registers Operation

All registers of MAC Core are 8-bit wide and mapped into pages which are selected by PS in the Command Register.

PAGE 0 (PS1=0,PS0=0)

OFFSET	READ	WRITE
00H	Command Register (CR)	Command Register (CR)
01H	Page Start Register (PSTART)	Page Start Register (PSTART)
02H	Page Stop Register (PSTOP)	Page Stop Register (PSTOP)
03H	Boundary Pointer (BNR)	Boundary Pointer (BNR)
04H	Transmit Status Register (TSR)	Transmit Page Start Address (TPSR)
05H	Number of Collisions Register (NCR)	Transmit Byte Count Register 0 (TBCR0)
06H	Current Page Register (CPR)	Transmit Byte Count Register 1 (TBCR1)
07H	Interrupt Status Register (ISR)	Interrupt Status Register (ISR)
08H	Current Remote DMA Address 0 (CRDA0)	Remote Start Address Register 0 (RSAR0)
09H	Current Remote DMA Address 1 (CRDA1)	Remote Start Address Register 1 (RSAR1)
0AH	Reserved	Remote Byte Count 0 (RBCR0)
0BH	Reserved	Remote Byte Count 1 (RBCR1)
0CH	Receive Status Register (RSR)	Receive Configuration Register (RCR)
0DH	Frame Alignment Errors (CNTR0)	Transmit Configuration Register (TCR)
0EH	CRC Errors (CNTR1)	Data Configuration Register (DCR)
0FH	Missed Packet Errors (CNTR2)	Interrupt Mask Register (IMR)
10H, 11H	Data Port	Data Port
12H	IFGS1	IFGS1
13H	IFGS2	IFGS2
14H	MII/EEPROM Access	MII/EEPROM Access
15H	-	Test Register
16H	Inter-frame Gap (IFG)	Inter-frame Gap (IFG)
17H	Reserved	Reserved
18H - 1AH	Standard Printer Port (SPP)	Standard Printer Port (SPP)
1BH - 1EH	Reserved	Reserved
1FH	Reset	Reserved

Tab - 10 Page 0 of MAC Core Registers Mapping



PAGE 1 (PS1=0,PS0=1)

OFFSET	READ	WRITE
00H	Command Register (CR)	Command Register (CR)
01H	Physical Address Register 0 (PARA0)	Physical Address Register 0 (PAR0)
02H	Physical Address Register 1 (PARA1)	Physical Address Register 1 (PAR1)
03H	Physical Address Register 2 (PARA2)	Physical Address Register 2 (PAR2)
04H	Physical Address Register 3 (PARA3)	Physical Address Register 3 (PAR3)
05H	Physical Address Register 4 (PARA4)	Physical Address Register 4 (PAR4)
06H	Physical Address Register 5 (PARA5)	Physical Address Register 5 (PAR5)
07H	Current Page Register (CPR)	Current Page Register (CPR)
08H	Multicast Address Register 0 (MAR0)	Multicast Address Register 0 (MAR0)
09H	Multicast Address Register 1 (MAR1)	Multicast Address Register 1 (MAR1)
0AH	Multicast Address Register 2 (MAR2)	Multicast Address Register 2 (MAR2)
0BH	Multicast Address Register 3 (MAR3)	Multicast Address Register 3 (MAR3)
0CH	Multicast Address Register 4 (MAR4)	Multicast Address Register 4 (MAR4)
0DH	Multicast Address Register 5 (MAR5)	Multicast Address Register 5 (MAR5)
0EH	Multicast Address Register 6 (MAR6)	Multicast Address Register 6 (MAR6)
0FH	Multicast Address Register 7 (MAR7)	Multicast Address Register 7 (MAR7)
10H, 11H	Data Port	Data Port
12H	Inter-frame Gap Segment 1 IFGS1	Inter-frame Gap Segment 1 IFGS1
13H	Inter-frame Gap Segment 2 IFGS2	Inter-frame Gap Segment 2 IFGS2
14H	MII/EEPROM Access	MII/EEPROM Access
15H	-	Test Register
16H	Inter-frame Gap (IFG)	Inter-frame Gap (IFG)
17H	Reserved	Reserved
18H - 1AH	Standard Printer Port (SPP)	Standard Printer Port (SPP)
1BH - 1EH	Reserved	Reserved
1FH	Reset	Reserved

Tab - 11 Page 1 of MAC Core Registers Mapping

**4.1 Command Register (CR) Offset 00H (Read/Write)**

FIELD	NAME	DESCRIPTION																								
7:6	PS1,PS0	PS1,PS0 : Page Select The two bit selects which register page is to be accessed. <table style="margin-left: 40px;"> <tr> <td>PS1</td> <td>PS0</td> <td></td> </tr> <tr> <td>0</td> <td>0</td> <td>page 0</td> </tr> <tr> <td>0</td> <td>1</td> <td>page 1</td> </tr> </table>	PS1	PS0		0	0	page 0	0	1	page 1															
PS1	PS0																									
0	0	page 0																								
0	1	page 1																								
5:3	RD2,RD1,RD0	RD2,RD1,RD0 : Remote DMA Command These three encoded bits control operation of the Remote DMA channel. RD2 could be set to abort any Remote DMA command in process. RD2 is reset by AX88196 when a Remote DMA has been completed. The Remote Byte Count should be cleared when a Remote DMA has been aborted. The Remote Start Address are not restored to the starting address if the Remote DMA is aborted. <table style="margin-left: 40px;"> <tr> <td>RD2</td> <td>RD1</td> <td>RD0</td> <td></td> </tr> <tr> <td>0</td> <td>0</td> <td>0</td> <td>Not allowed</td> </tr> <tr> <td>0</td> <td>0</td> <td>1</td> <td>Remote Read</td> </tr> <tr> <td>0</td> <td>1</td> <td>0</td> <td>Remote Write</td> </tr> <tr> <td>0</td> <td>1</td> <td>1</td> <td>Not allowed</td> </tr> <tr> <td>1</td> <td>X</td> <td>X</td> <td>Abort / Complete Remote DMA</td> </tr> </table>	RD2	RD1	RD0		0	0	0	Not allowed	0	0	1	Remote Read	0	1	0	Remote Write	0	1	1	Not allowed	1	X	X	Abort / Complete Remote DMA
RD2	RD1	RD0																								
0	0	0	Not allowed																							
0	0	1	Remote Read																							
0	1	0	Remote Write																							
0	1	1	Not allowed																							
1	X	X	Abort / Complete Remote DMA																							
2	TXP	TXP : Transmit Packet This bit could be set to initiate transmission of a packet																								
1	START	START : This bit is used to active AX88196 operation.																								
0	STOP	STOP : Stop AX88196 This bit is used to stop the AX88196 operation.																								

4.2 Interrupt Status Register (ISR) Offset 07H (Read/Write)

FIELD	NAME	DESCRIPTION
7	RST	Reset Status : Set when AX88196 enters reset state and cleared when a start command is issued to the CR. Writing to this bit is no effect.
6	RDC	Remote DMA Complete Set when remote DMA operation has been completed
5	CNT	Counter Overflow Set when MSB of one or more of the Tally Counters has been set.
4	OVW	OVERWRITE : Set when receive buffer ring storage resources have been exhausted.
3	TXE	Transmit Error Set when packet transmitted with one or more of the following errors <ul style="list-style-type: none"> ■ Excessive collisions ■ FIFO Underrun
2	RXE	Receive Error Indicates that a packet was received with one or more of the following errors <ul style="list-style-type: none"> CRC error Frame Alignment Error FIFO Overrun Missed Packet
1	PTX	Packet Transmitted Indicates packet transmitted with no error
0	PRX	Packet Received Indicates packet received with no error.

**4.3 Interrupt mask register (IMR) Offset 0FH (Write)**

FIELD	NAME	DESCRIPTION
7	-	Reserved
6	RDCE	DMA Complete Interrupt Enable. Default "low" disabled.
5	CNTE	Counter Overflow Interrupt Enable. Default "low" disabled.
4	OVWE	Overwrite Interrupt Enable. Default "low" disabled.
3	TXEE	Transmit Error Interrupt Enable. Default "low" disabled.
2	RXEE	Receive Error Interrupt Enable. Default "low" disabled.
1	PTXE	Packet Transmitted Interrupt Enable. Default "low" disabled.
0	PRXE	Packet Received Interrupt Enable. Default "low" disabled.

4.4 Data Configuration Register (DCR) Offset 0EH (Write)

FIELD	NAME	DESCRIPTION
7	RDCR	Remote DMA always completed
6:2	-	Reserved
1	BOS	Byte Order Select 0: MS byte placed on AD15:AD8 and LS byte on AD7-AD0 (80186). 1: MS byte placed on AD7::AD0 and LS byte on AD15:AD0(MC68K)
0	WTS	Word Transfer Select 0 : Selects byte-wide DMA transfers. 1 : Selects word-wide DMA transfers.

4.5 Transmit Configuration Register (TCR) Offset 0DH (Write)

FIELD	NAME	DESCRIPTION																
7	FDU	Full Duplex : This bit indicates the current media mode is Full Duplex or not. 0 : Half duplex 1 : Full duplex																
6	PD	Pad Disable 0 : Pad will be added when packet length less than 60. 1 : Pad will not be added when packet length less than 60.																
5	RLO	Retry of late collision 0 : Don't retransmit packet when late collision happens. 1 : Retransmit packet when late collision happens.																
4:3	-	Reserved																
2:1	LB1, LB0	Encoded Loop-back Control These encoded configuration bits set the type of loop-back that is to be performed. <table border="0" style="margin-left: 20px;"> <tr> <td></td> <td>LB1</td> <td>LB0</td> <td></td> </tr> <tr> <td>Mode 0</td> <td>0</td> <td>0</td> <td>Normal operation</td> </tr> <tr> <td>Mode 1</td> <td>0</td> <td>1</td> <td>Internal NIC loop-back</td> </tr> <tr> <td>Mode 2</td> <td>1</td> <td>0</td> <td>PHYceiver loop-back</td> </tr> </table>		LB1	LB0		Mode 0	0	0	Normal operation	Mode 1	0	1	Internal NIC loop-back	Mode 2	1	0	PHYceiver loop-back
	LB1	LB0																
Mode 0	0	0	Normal operation															
Mode 1	0	1	Internal NIC loop-back															
Mode 2	1	0	PHYceiver loop-back															
0	CRC	Inhibit CRC 0 : CRC appended by transmitter. 1 : CRC inhibited by transmitter.																

**4.6 Transmit Status Register (TSR) Offset 04H (Read)**

FIELD	NAME	DESCRIPTION
7	OWC	Out of window collision
6:4	-	Reserved
3	ABT	Transmit Aborted Indicates the AX88196 aborted transmission because of excessive collision.
2	COL	Transmit Collided Indicates that the transmission collided at least once with another station on the network.
1	-	Reserved
0	PTX	Packet Transmitted Indicates transmission without error.

4.7 Receive Configuration (RCR) Offset 0CH (Write)

FIELD	NAME	DESCRIPTION
7	-	Reserved
6	INTT	Interrupt Trigger Mode for ISA and 80186 modes 0 : Low active 1 : High active (default) Interrupt Trigger Mode for MCS-51 and MC68K modes 0 : High active 1 : Low active (default)
5	MON	Monitor Mode 0 : Normal Operation 1 : Monitor Mode, the input packet will be checked on NODE ADDRESS and CRC but not buffered into memory.
4	PRO	PRO : Promiscuous Mode Enable the receiver to accept all packets with a physical address.
3	AM	AM : Accept Multicast Enable the receiver to accept packets with a multicast address. That multicast address must pass the hashing array.
2	AB	AB : Accept Broadcast Enable the receiver to accept broadcast packet.
1	AR	AR : Accept Runt Enable the receiver to accept runt packet.
0	SEP	SEP : Save Error Packet Enable the receiver to accept and save packets with error.

4.8 Receive Status Register (RSR) Offset 0CH (Read)

FIELD	NAME	DESCRIPTION
7	-	Reserved
6	DIS	Receiver Disabled
5	PHY	Multicast Address Received.
4	MPA	Missed Packet
3	FO	FIFO Overrun
2	FAE	Frame alignment error.
1	CR	CRC error.
0	PRX	Packet Received Intact

**4.9 Inter-frame gap (IFG) Offset 16H (Read/Write)**

FIELD	NAME	DESCRIPTION
7	-	Reserved
6:0	IFG	Inter-frame Gap. Default value 15H.

4.10 Inter-frame gap Segment 1(IFGS1) Offset 12H (Read/Write)

FIELD	NAME	DESCRIPTION
7	-	Reserved
6:0	IFG	Inter-frame Gap Segment 1. Default value 0cH.

4.11 Inter-frame gap Segment 2(IFGS2) Offset 13H (Read/Write)

FIELD	NAME	DESCRIPTION
7	-	Reserved
6:0	IFG	Inter-frame Gap Segment 2. Default value 11H.

4.12 MII/EEPROM Management Register (MEMR) Offset 14H (Read/Write)

FIELD	NAME	DESCRIPTION
7	EECLK	EECLK EEPROM Clock
6	EEO	EEO EEPROM Data Out
5	EEI	EEI EEPROM Data In
4	EECS	EECS EEPROM Chip Select
3	MDO	MDO MII Data Out
2	MDI	MDI MII Data In
1	MDIR	MII STA MDIO signal Direction MII Read Control Bit, assert this bit let MDIO signal as the input signal. Deassert this bit let MDIO as output signal.
0	MDC	MDC MII Clock

4.13 Test Register (TR) Offset 15H (Write)

FIELD	NAME	DESCRIPTION
7	-	Reserved
6	MPSEL	Media Priority Select : default value is logic 0 MPSEL /SLINK Media Selected 0 0 SNI 0 1 MII 1 x Depend on MPSET bit
5	MPSET	Media Set by Program : The signal is valid only when MPSEL is set to high. When MPSET is logic 0 , SNI is selected. When MPSET is logic 1 , MII is selected.
4	TF16T	Test for Collision, default value is logic 0
3	TPE	Test pin Enable, default value is logic 0
2:0	IFG	Select Test Pins Output, default value is logic 0

**4.14 SPP Data Port Register (SPP_DPR) Offset 18H (Read/Write)**

FIELD	NAME	DESCRIPTION
7:0	DP	Printer Data Port

4.15 SPP Status Port Register (SPP_SPR) Offset 19H (Read)

FIELD	NAME	DESCRIPTION
7	/BUSY	Reading a '0' indicates that the printer is not ready to receive new data.
6	/ACK	Reading a '0' indicates that the printer has received the data and is ready to accept new data.
5	PE	Reading a '1' indicates that the printer is out of paper.
4	SLCT	Reading a '1' indicates that the printer has power on.
3	/ERR	Reading a '0' indicates that there is an error condition at the printer.
2:0	-	Reserved

4.16 SPP Command Port Register (SPP_CPR) Offset 1AH (Read/Write)

FIELD	NAME	DESCRIPTION
7:6	-	Reserved
5	/DOE	Setting to '0' enable print data output to printer. Default sets to '1'.
4	IRQEN	IRQ enable : printer port interrupt is not supported.
3	SLCTIN	Setting to '1' selects the printer.
2	/INIT	Setting to '0' initiates the printer
1	ATFD	Setting to '1' causes the printer to automatically feed one line after each line is printed.
0	STRB	Setting a low-high-low pulse on this register is used to strobe the print data into the printer.



5.0 CPU I/O Read and Write Functions

The AX88196 supports four kinds of CPU/BUS types access function, including ISA, 80186, MC68000 and MCS-51. These Access methods are described as the following sections.

5.1 ISA bus type access functions.

ISA bus I/O Read function

Function Mode	/CS	/BHE	A0	/IORD	/IOWR	SD[15:8]	SD[7:0]
Standby Mode	H	X	X	X	X	High-Z	High-Z
Byte Access	L	H	L	L	H	Not Valid	Even-Byte
	L	H	H	L	H	Not Valid	Odd-Byte
Word Access	L	L	L	L	H	Odd-Byte	Even-Byte

ISA bus I/O Write function

Function Mode	/CS	/BHE	A0	/IORD	/IOWR	SD[15:8]	SD[7:0]
Standby Mode	H	X	X	X	X	X	X
Byte Access	L	H	L	H	L	X	Even-Byte
	L	H	H	H	L	X	Odd-Byte
Word Access	L	L	L	H	L	Odd-Byte	Even-Byte

5.2 80186 CPU bus type access functions.

80186 CPU bus I/O Read function

Function Mode	/CS	/BHE	A0	/IORD	/IOWR	SD[15:8]	SD[7:0]
Standby Mode	H	X	X	X	X	High-Z	High-Z
Byte Access	L	H	L	L	H	Not Valid	Even-Byte
	L	L	H	L	H	Odd-Byte	Not Valid
Word Access	L	L	L	L	H	Odd-Byte	Even-Byte

80186 CPU bus I/O Write function

Function Mode	/CS	/BHE	A0	/IORD	/IOWR	SD[15:8]	SD[7:0]
Standby Mode	H	X	X	X	X	X	X
Byte Access	L	H	L	H	L	X	Even-Byte
	L	L	H	H	L	Odd-Byte	X
Word Access	L	L	L	H	L	Odd-Byte	Even-Byte



5.3 MC68K CPU bus type access functions.

68K bus I/O Read function

Function Mode	/CS	/UDS	/LDS	R/W	SD[15:8]	SD[7:0]
Standby Mode	H	X	X	X	High-Z	High-Z
Byte Access	L	H	L	H	Not Valid	Odd-Byte
	L	L	H	H	Even-Byte	Not Valid
Word Access	L	L	L	H	Even-Byte	Odd-Byte

68K bus I/O Write function

Function Mode	/CS	/UDS	/LDS	R/W	SD[15:8]	SD[7:0]
Standby Mode	H	X	X	X	X	X
Byte Access	L	H	L	L	X	Odd-Byte
	L	L	H	L	Even-Byte	X
Word Access	L	L	L	L	Even-Byte	Odd-Byte

5.4 MCS-51 CPU bus type access functions.

8051 bus I/O Read function

Function Mode	/CS	/PSEN	SA0	/IORD	/IOWR	SD[15:8]	SD[7:0]
Standby Mode	H	X	X	X	X	High-Z	High-Z
	X	L	X	X	X	High-Z	High-Z
Byte Access	L	H	L	L	H	Not Valid	Even-Byte
	L	H	H	L	H	Not Valid	Odd-Byte

8051 bus I/O Write function

Function Mode	/CS	/PSEN	SA0	/IORD	/IOWR	SD[15:8]	SD[7:0]
Standby Mode	H	X	X	X	X	X	X
	X	L	X	X	X	X	X
Byte Access	L	H	L	H	L	X	Even-Byte
	L	H	H	H	L	X	Odd-Byte



6.0 Electrical Specification and Timings

6.1 Absolute Maximum Ratings

Description	SYM	Min	Max	Units
Operating Temperature	Ta	0	+85	°C
Storage Temperature	Ts	-55	+150	°C
Supply Voltage	HVdd	-0.3	+6	V
Supply Voltage	LVdd	-0.3	+4.6	V
Input Voltage	HVin	-0.3	HVdd+0.5	V
	LVin	-0.3	LVdd+0.5	V
Output Voltage	HVout	-0.3	HVdd+0.5	V
	LVin	-0.3	LVdd+0.5	V
Lead Temperature (soldering 10 seconds maximum)	Tl	-55	+220	°C

Note : Stress above those listed under Absolute Maximum Ratings may cause permanent damage to the device.

Exposure to Absolute Maximum Ratings conditions for extended period, adversely affect device life and reliability.

Note : The power supply voltages must always fulfill HVdd >= LVdd inequality.

6.2 General Operation Conditions

Description	SYM	Min	Tpy	Max	Units
Operating Temperature	Ta	0	25	+75	°C
Supply Voltage	HVdd	+4.75V	+5.00V	+5.25V	V
	LVdd	+2.70	+3.00	+3.30	V
		+3.00	+3.30	+3.60	V

Note : The power supply voltages must always fulfill HVdd >= LVdd inequality.

6.3 DC Characteristics

(Vdd=5.0V, Vss=0V, Ta=0°C to 75°C)

Description	SYM	Min	Tpy	Max	Units
Low Input Voltage	Vil	-		0.8	V
High Input Voltage	Vih	2		-	V
Low Output Voltage	Vol	-		0.4	V
High Output Voltage	Voh	Vdd-0.4		-	V
Input Leakage Current	Iil	-1		+1	uA
Output Leakage Current	Iol	-1		+1	uA

(Vdd=3.0V to 3.6V, Vss=0V, Ta=0°C to 75°C)

Description	SYM	Min	Tpy	Max	Units
Low Input Voltage	Vil	-		0.8	V
High Input Voltage	Vih	1.9		-	V
Low Output Voltage	Vol	-		0.4	V
High Output Voltage	Voh	Vdd-0.4		-	V
Input Leakage Current	Iil	-1		+1	uA
Output Leakage Current	Iol	-1		+1	uA

Description	SYM	Min	Tpy	Max	Units
Power Consumption (Dual power)	DPt5v		20		mA
	DPt3v		32		mA
Power Consumption (Single power 3.3V)	SPT3v		50		mA



6.4 A.C. Timing Characteristics

6.4.1 XTAL / CLOCK

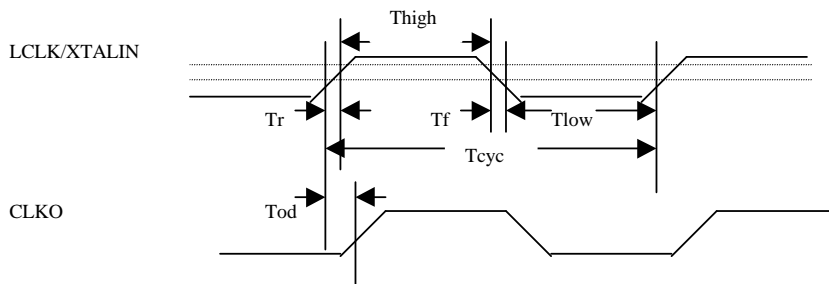

Symbol	Description	Min	Typ.	Max	Units
Tcyc	CYCLE TIME		40*		ns
Thigh	CLK HIGH TIME	16	20	24	ns
Tlow	CLK LOW TIME	16	20	24	ns
Tr/Tf	CLK SLEW RATE	1	-	4	ns
Tod	LCLK/XTALIN TO CLKO OUT DELAY		10		

* Note : The Tcyc can be from 16.6ns to 50ns, that is frequency from 60MHz to 20MHz.

6.4.2 Reset Timing

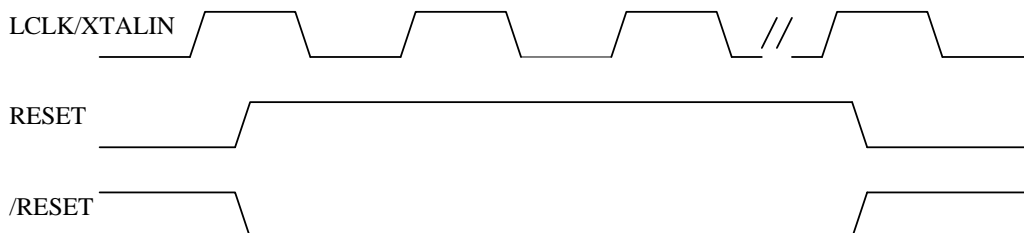

Symbol	Description	Min	Typ.	Max	Units
Trst	Reset pulse width	100	-	-	LCIk



6.4.3 ISA Bus Access Timing

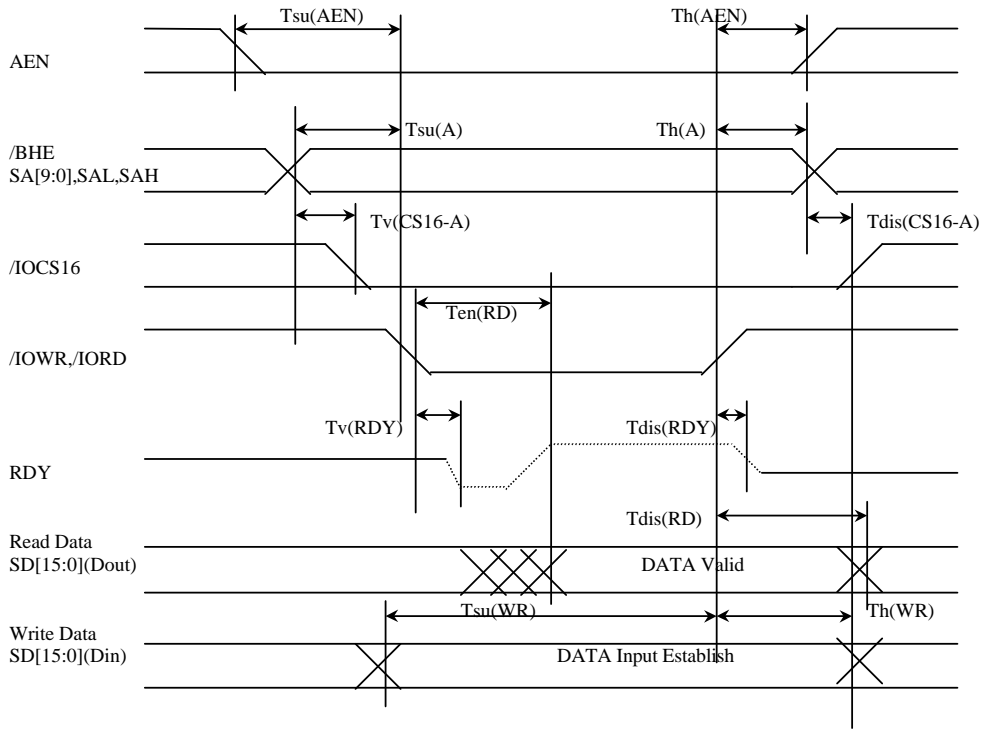

Symbol	Description	Min	Typ.	Max	Units
Tsu(A)	ADDRESS SETUP TIME	0	-	-	ns
Th(A)	ADDRESS HOLD TIME	5	-	-	ns
Tsu(AEN)	AEN SETUP TIME	0	-	-	ns
Th(AEN)	AEN HOLD TIME	5	-	-	ns
Tv(CS16-A)	/IOCS16 VALID FROM ADDRESS CHANGE	-	-	20	ns
Tdis(CS16-A)	/IOCS16 DISABLE FROM ADDRESS CHANGE	-	-	6	ns
Tv(RDY)	RDY VALID FROM /IORD OR /IOWR	-	-	20	ns
Tdis(RDY)	RDY DISABLE FROM /IORD OR /IOWR	0	-	-	ns
Ten(RD)	OUTPUT ENABLE TIME FROM /IORD	-	-	20	ns
Tdis(RD)	OUTPUT DISABLE TIME FROM /IORD	0.5	-	4	ns
Tsu(WR)	DATA SETUP TIME	5	-	-	ns
Th(WR)	DATA HOLD TIME	5	-	-	ns



6.4.4 80186 Type I/O Access Timing

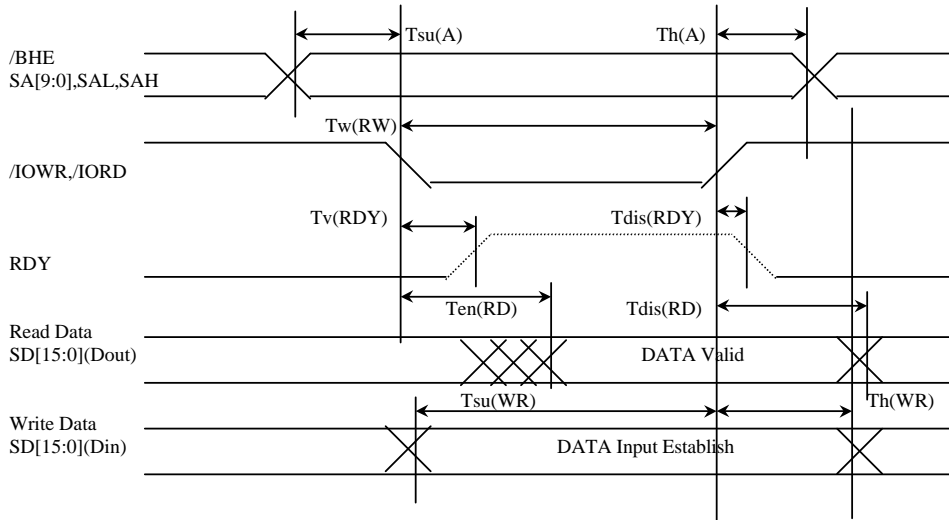

Symbol	Description	Min	Typ.	Max	Units
$T_{su}(A)$	ADDRESS SETUP TIME	0	-	-	ns
$T_h(A)$	ADDRESS HOLD TIME	5	-	-	ns
$T_v(RDY)$	RDY VALID FROM /IORD OR /IOWR	-	-	20	ns
$T_{dis}(RDY)$	RDY DISABLE FROM /IORD OR /IOWR	0	-	-	ns
$T_{en}(RD)$	OUTPUT ENABLE TIME FROM /IORD	-	-	20	ns
$T_{dis}(RD)$	OUTPUT DISABLE TIME FROM /IORD	0.5	-	4	ns
$T_{su}(WR)$	DATA SETUP TIME	5	-	-	ns
$T_h(WR)$	DATA HOLD TIME	5	-	-	ns
$T_w(RW)$	/IORD OR /IOWR WIDTH TIME	*60			ns

*Note : 60 ns at internal operation clock is 20MHz.

50 ns at internal operation clock is 25MHz.



6.4.5 68K Type I/O Access Timing

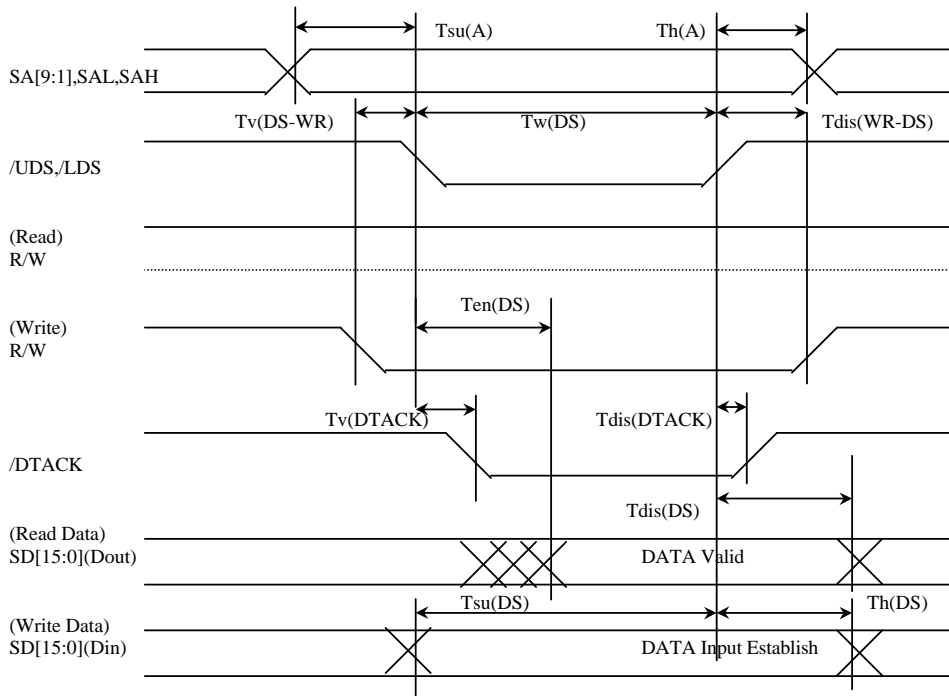

Symbol	Description	Min	Typ.	Max	Units
Tsu(A)	ADDRESS SETUP TIME	0	-	-	ns
Th(A)	ADDRESS HOLD TIME	5	-	-	ns
Tv(DS-WR)	/UDS OR /LDS VALID FROM /W	0	-	-	ns
Tdis(WR-DS)	/W DISABLE FROM /UDS OR /LDS	5	-	-	ns
Tv(DTACK)	DACK VALID FROM /UDS OR /LDS	-	-	20	ns
Tdis(DTACK)	DACK DISABLE FROM /UDS OR /LDS	0	-	-	ns
Ten(DS)	OUTPUT ENABLE TIME FROM /UDS OR /LDS	-	-	20	ns
Tdis(DS)	OUTPUT DISABLE TIME FROM /UDS OR /LDS	0.5	-	4	ns
Tsu(DS)	DATA SETUP TIME	5	-	-	ns
Th(DS)	DATA HOLD TIME	5	-	-	ns
Tw(DS)	/UDS OR /LDS WIDTH TIME	*60			ns

*Note : 60 ns at internal operation clock is 20MHz.

50 ns at internal operation clock is 25MHz.



6.4.6 8051 Bus Access Timing

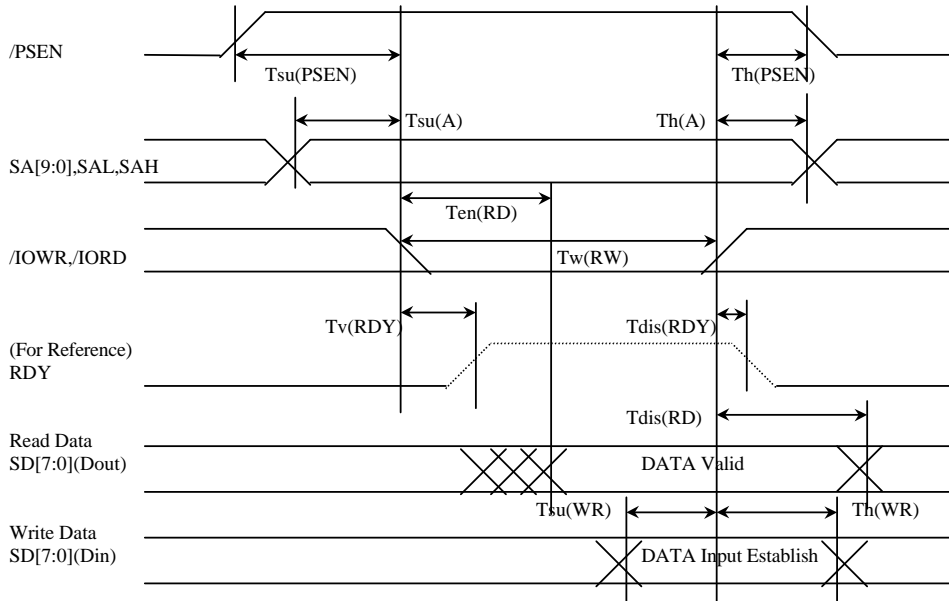

Symbol	Description	Min	Typ.	Max	Units
Tsu(A)	ADDRESS SETUP TIME	0	-	-	ns
Th(A)	ADDRESS HOLD TIME	5	-	-	ns
Tsu(PSEN)	/PSEN SETUP TIME	0	-	-	ns
Th(PSEN)	/PSEN HOLD TIME	5	-	-	ns
Ten(RD)	OUTPUT ENABLE TIME FROM /IORD	-	-	20	ns
Tdis(RD)	OUTPUT DISABLE TIME FROM /IORD	0.5	-	4	ns
Tsu(WR)	DATA SETUP TIME	5	-	-	ns
Th(WR)	DATA HOLD TIME	5	-	-	ns
Tw(RW)	/IORD OR /IOWR WIDTH TIME	*60			ns

Note : 60 ns at internal operation clock 20MHz.
50 ns at internal operation clock 25MHz.



6.4.7 MII Timing

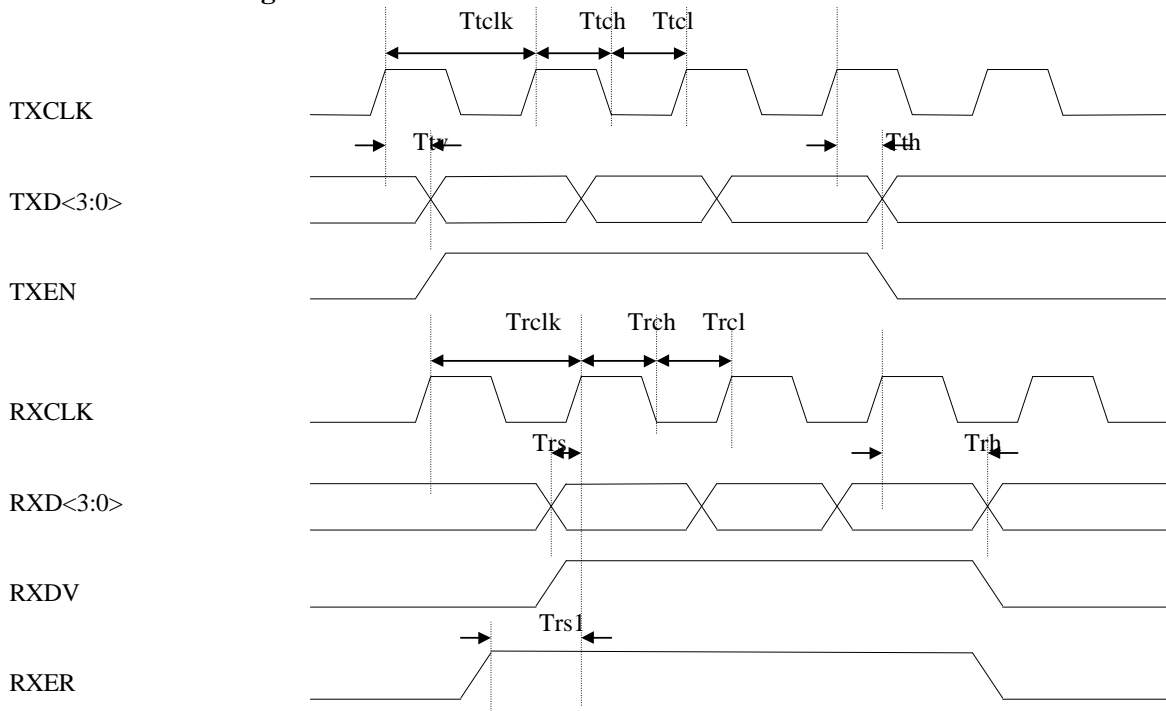

Symbol	Description	Min	Typ.	Max	Units
Ttclk	Cycle time(100Mbps)	-	40	-	ns
Ttclk	Cycle time(10Mbps)	-	400	-	ns
Ttch	high time(100Mbps)	14	-	26	ns
Ttch	high time(10Mbps)	140	-	260	ns
Trch	low time(100Mbps)	14	-	26	ns
Trch	low time(10Mbps)	140	-	260	ns
Ttv	Clock to data valid	-	-	20	ns
Tth	Data output hold time	5	-	-	ns
Trclk	Cycle time(100Mbps)	-	40	-	ns
Trclk	Cycle time(10Mbps)	-	400	-	ns
Trch	high time(100Mbps)	14	-	26	ns
Trch	high time(10Mbps)	140	-	260	ns
Trcl	low time(100Mbps)	14	-	26	ns
Trcl	low time(10Mbps)	140	-	260	ns
Trs	data setup time	6	-	-	ns
Trh	data hold time	10	-	-	ns
Trsl	RXER data setup time	10	-	-	ns



6.4.8 SNI Timing

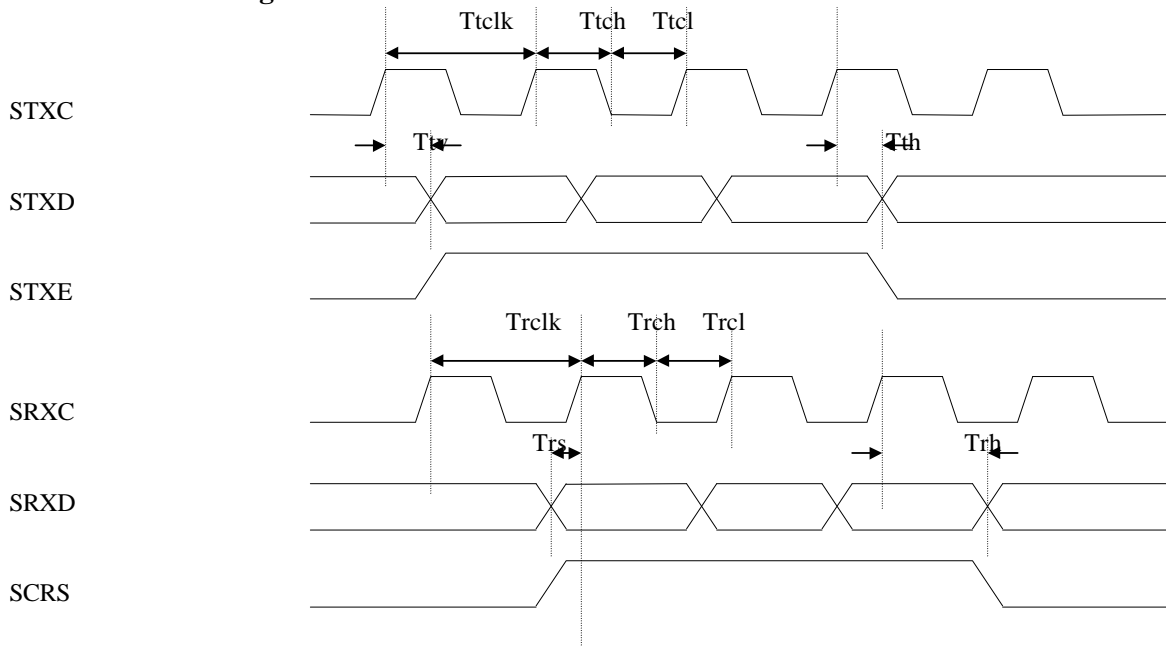

Symbol	Description	Min	Typ.	Max	Units
Ttclk	Cycle time(10Mbps)	-	100	-	ns
Ttch	high time(10Mbps)	45	-	55	ns
Trch	low time(10Mbps)	45	-	55	ns
Ttv	Clock to data valid	-	-	26	ns
Tth	Data output hold time	5	-	-	ns
Trclk	Cycle time(10Mbps)	-	100	-	ns
Trch	high time(10Mbps)	45	-	55	ns
Trcl	low time(10Mbps)	45	-	55	ns
Trs	data setup time	10	-	-	ns
Trh	data hold time	5	-	-	ns



7.0 Package Information

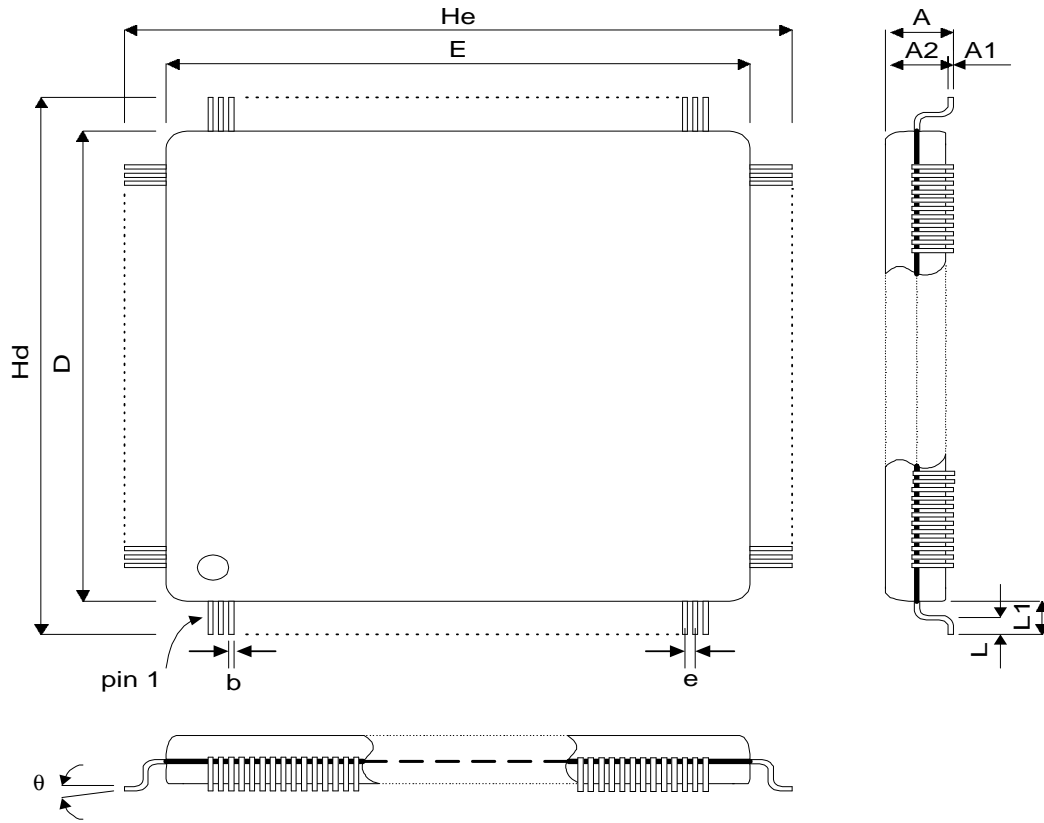

SYMBOL	MILIMETER		
	MIN.	NOM	MAX
A1		0.1	
A2	1.3	1.4	1.5
A			1.7
b	0.155	0.16	0.26
D	13.90	14.00	14.10
E	13.90	14.00	14.10
e		0.40	
Hd	15.60	16.00	16.40
He	15.60	16.00	16.40
L	0.30	0.50	0.70
L1		1.00	
θ	0		10



Appendix A: Application Note

A.1 Using Crystal 25MHz or 20MHz

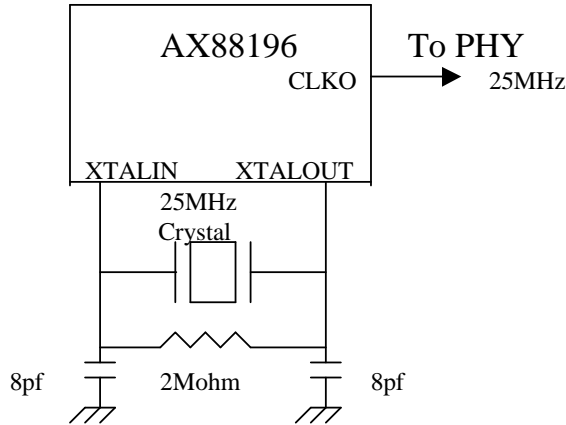

Note : The capacitors (8pf) may be various depend on the specification of crystal. While designing, please refer to the suggest circuit provided by crystal supplier.

A.2 Using Oscillator 25MHz or 20MHz

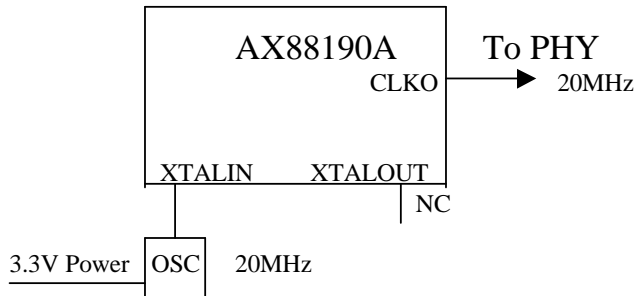

A.3 Using 60MHz Oscillator/Crystal

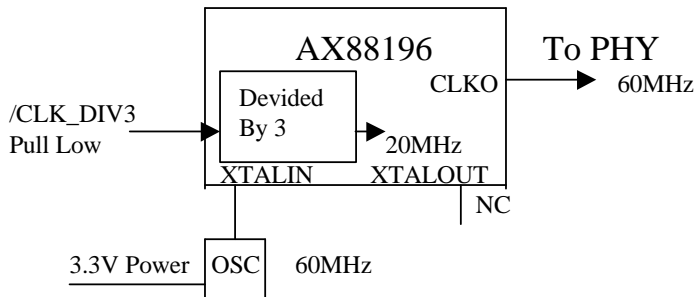



A.4 Dual power (5V and 3.3V/3.0V) application

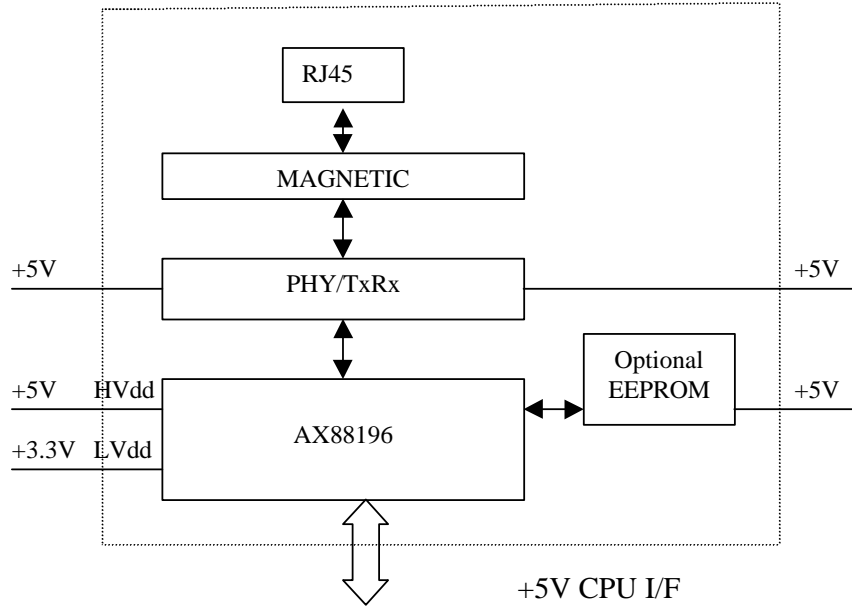

A.5 Single power (3.3V/3.0V) application

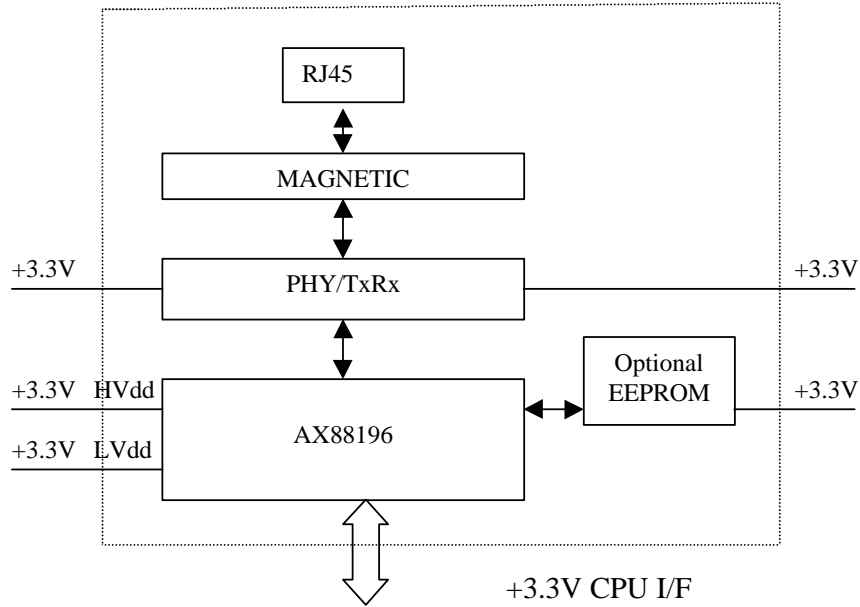



A.6 Dual power (5V and 3.3V) application with 3.3V PHY

The 510 and 1K Ohm resistors are just for voltage adjustment

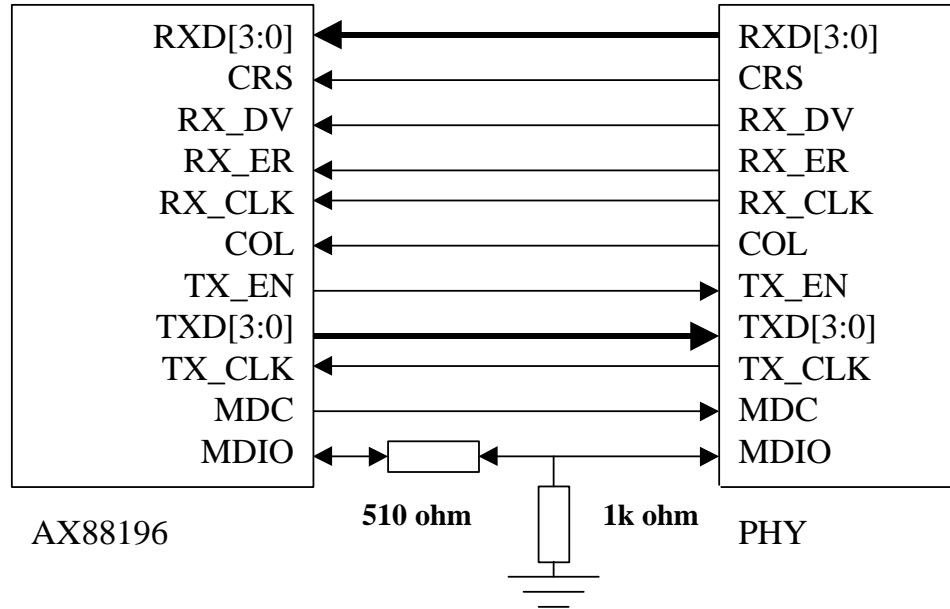



Errata of AX88196 Version ED2

- 1. SNI (Serial Network Interface) has bug for HomePNA application.
Solution: Using MII interface for HomePNA solution. Refer to “Demonstration Circuit” on page 37 to 41.**

- 2. SPP (Standard Printer Port) is fail on 186 and 68K modes. Because of can't read out correct information of x19h status port.
Solution: This version do not support SPP function on the two modes. If user want to use general purpose port for reading external status. Please using x18h data port to replaces it.**

- 3. SPP command port readback value is from internal registers instead of external pins
Solution: ASIX will not fix the problem at this moment. Care must be taken when doing the external pins diagnostic.**

- 4. DTACK can't fit 68K CPU timing in 68K mode
Solution : Using the DTACK automatic insertion function in 68K CPU.**



AX88196

10/100BASE Fast Ethernet MAC Controller

Demonstration Circuit : AX88196 + Ethernet PHY + HomePNA 1M8 PHY

AX88196 L 10BASE-T/100BASE-TX & 1M HomePNA APPLICATION WITH DP83846 & DP83851 (FOR ISA MODE) (REFERENCE OI

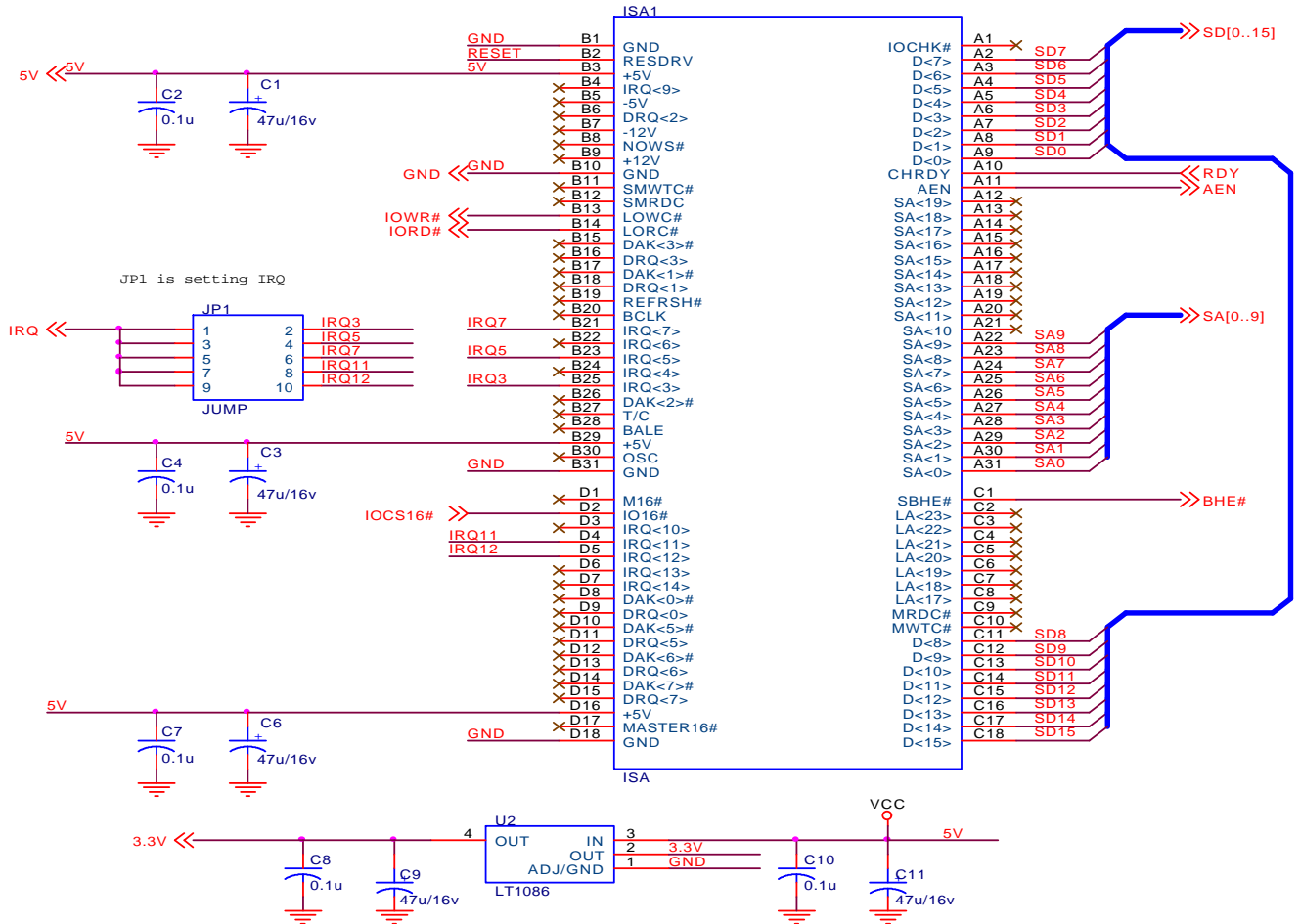



AX88196

10/100BASE Fast Ethernet MAC Controller

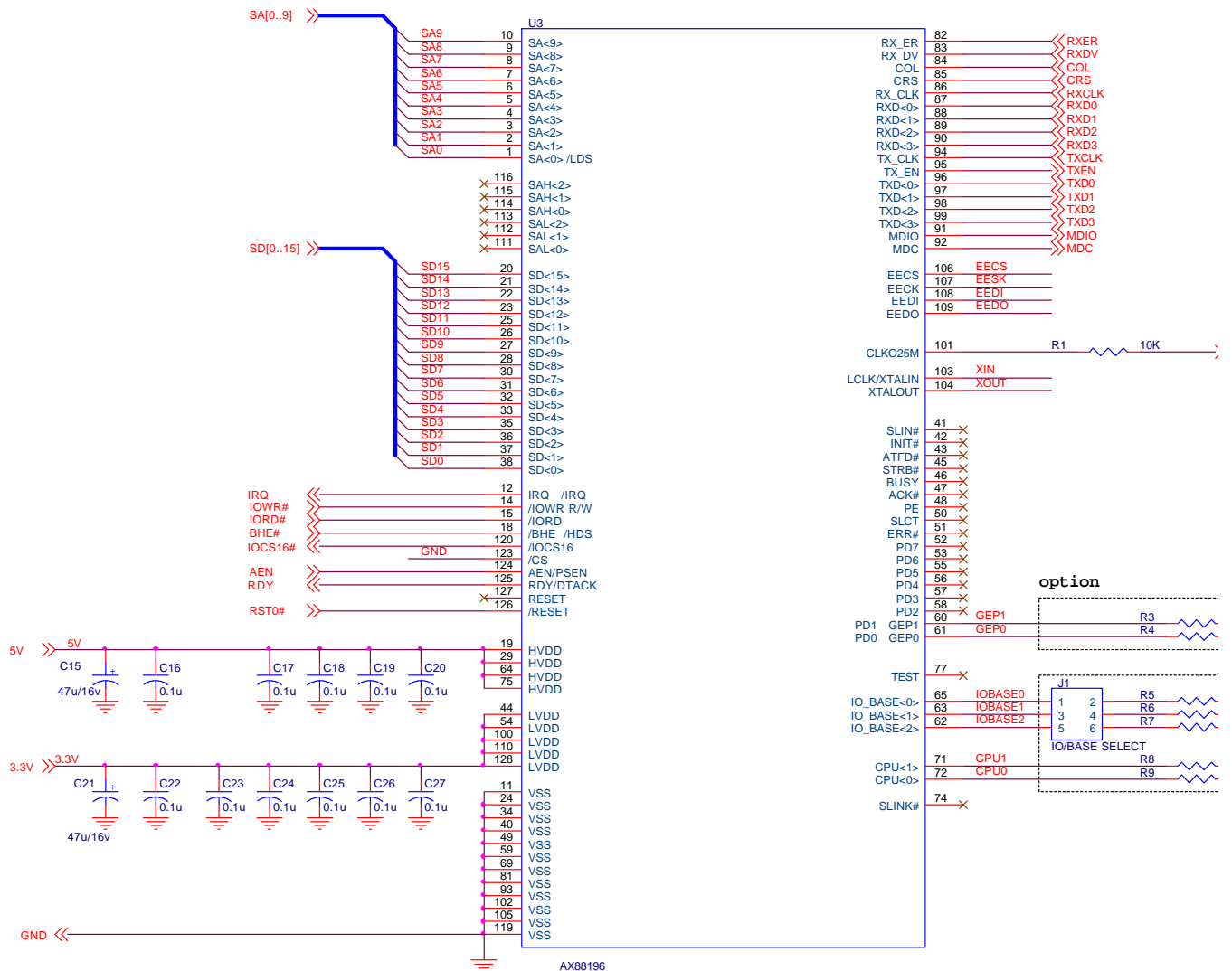



AX88196

10/100BASE Fast Ethernet MAC Controller

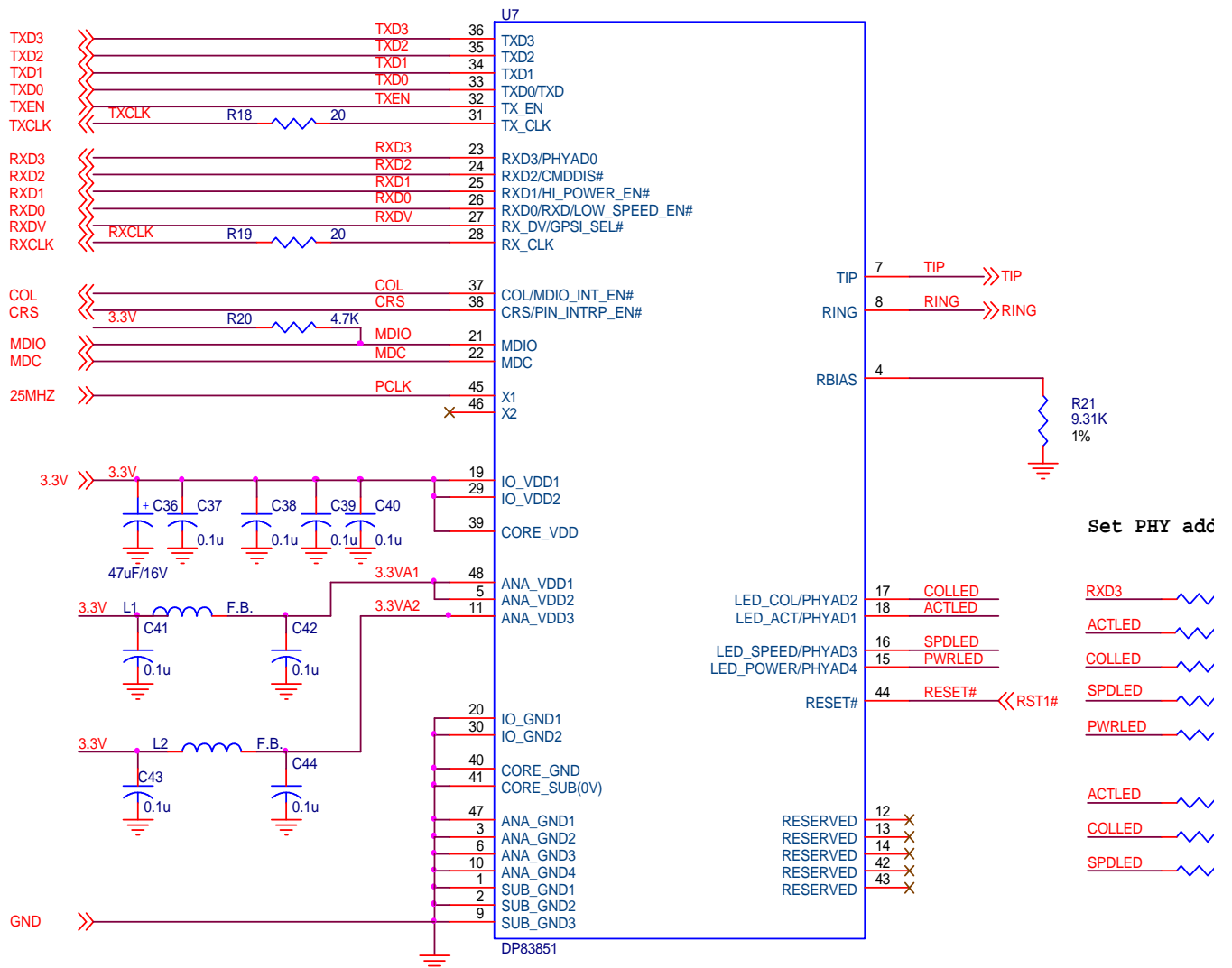

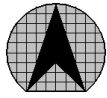

AX88196

10/100BASE Fast Ethernet MAC Controller

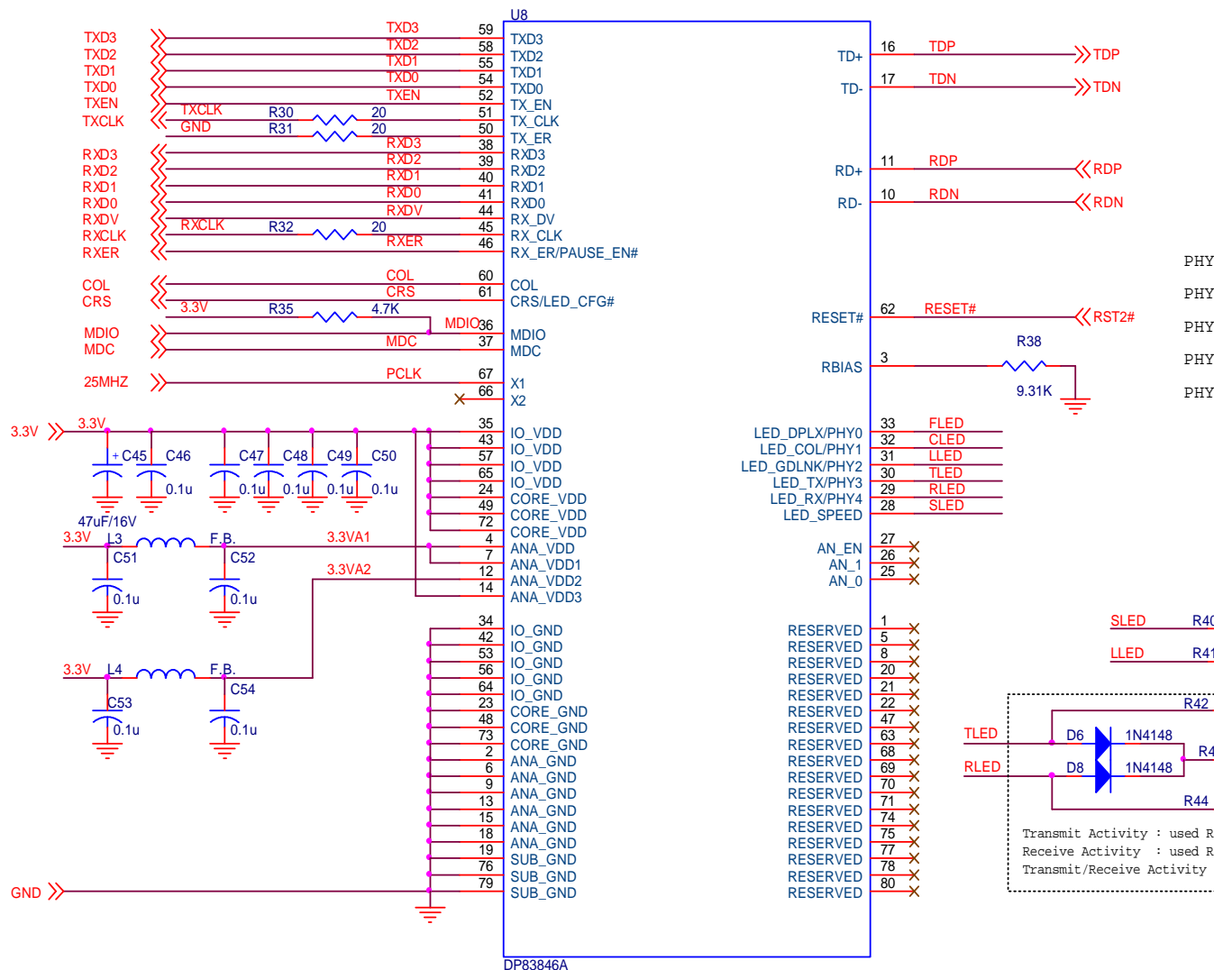



AX88196

10/100BASE Fast Ethernet MAC Controller

