

---

# REALTEK SINGLE CHIP SINGLE PORT 10/100MBPS FAST ETHERNET PHYCEIVER RTL8201(L)

---

<b>1. Features</b> .....	<b>2</b>	6.13 Register 22 PHY 2 .....	16
<b>2. General Description</b> .....	<b>2</b>	6.14 Register 23 Twister_1 .....	16
<b>3. Block Diagram</b> .....	<b>3</b>	6.15 Register 24 Twister_2 .....	16
<b>4. Pin Assignments</b> .....	<b>4</b>	<b>7. Functional Description</b> .....	<b>17</b>
<b>5. Pin Description</b> .....	<b>5</b>	7.1 MII and Management Interface.....	17
5.1 100 Mbps MII & PCS Interface .....	5	7.2 Auto-negotiation and Parallel Detection .....	18
5.2 Serial Network Interface (SNI) .....	5	7.3 Flow control support .....	18
5.3 Clock Interface .....	5	7.4 Hardware Configuration and Auto-negotiation .....	19
5.4 100Mbps Network Interface.....	6	7.5 LED and PHY Address Configuration .....	20
5.5 Device Configuration Interface.....	6	7.6 Serial Network Interface .....	20
5.6 LED Interface/PHY Address Config.....	6	7.7 Power Down, Link Down, Power Saving, and Isolation Modes	21
5.7 Reset and Test pins.....	6	7.8 Media Interface .....	21
5.8 Power and Ground pins.....	6	7.8.1 100Base Tx/Rx .....	21
<b>6. Register Descriptions</b> .....	<b>7</b>	7.8.2 10Base Tx/Rx .....	22
6.1 Register 0 Basic Mode Control .....	7	7.9 Repeater Mode Operation .....	22
6.2 Register 1 Basic Mode Status.....	9	7.10 Reset, Power, and Transmit Bias.....	22
6.3. Register 2 PHY Identifier 1.....	10	<b>8. Electrical Characteristics</b> .....	<b>23</b>
6.4. Register 3 PHY Identifier 2.....	10	8.1 D.C. Characteristics .....	23
6.5. Register 4 Auto-negotiation Advertisement .....	11	8.1.1. Absolute Maximum Ratings .....	23
6.6 Register 5 Auto-Negotiation Link Partner Ability .....	12	8.1.2. Operating Conditions.....	23
6.7 Register 6 Auto-negotiation Expansion (ANER) .....	14	8.1.3. Power Dissipation.....	23
6.8 Register 16 Nway Setup (NSR).....	14	8.1.4 Supply Voltage: Vcc .....	23
6.9 Register 17 Loopback Bypass Receiver Error Mask (LBREMR).....	15	8.2 A.C. Characteristics .....	24
6.10 Register 18 RX_ER Counter (REC).....	15	8.2.1 Transmission Without Collision .....	24
6.11 Register 19 10Mbps Network Interface Configuration .....	15	8.2.2 Reception Without Error.....	24
6.12 Register 20 PHY 1_1.....	15	<b>9. Mechanical Dimensions</b> .....	<b>25</b>
6.13 Register 21 PHY 1_2.....	16		

## 1. Features

The Realtek RTL8201(L) is a Fast Ethernet Phyceiver with MII interface to the MAC chip. It provides the following features:

- Supports MII interface
- Supports 10/100Mbps operation
- Supports half/full duplex operation
- IEEE 802.3/802.3u compliant
- Supports IEEE 802.3u clause 28 auto negotiation
- Supports power down mode
- Supports operation under Link Down Power Saving mode
- Supports repeater mode
- Speed/duplex/auto negotiation adjustable
- 3.3V operation with 5V signal tolerance
- Low operation power consumption
- Adaptive Equalization
- 25MHz crystal/oscillator as clock source
- Multiple network status LED support
- Supports 7-wire SNI (Serial Network Interface) interface
- Flow control ability support to co-work with MAC (by MDC/MDIO)
- 48-pin LQFP package

## 2. General Description

The RTL8201(L) is a single-port Phyceiver with an MII (Media Independent Interface). It implements all 10/100M Ethernet Physical-layer functions including the Physical Coding Sublayer (PCS), Physical Medium Attachment (PMA), Twisted Pair Physical Medium Dependent Sublayer (TP-PMD), 10Base-Tx Encoder/Decoder and Twisted Pair Media Access Unit (TPMAU). It is fabricated with an advanced CMOS process to meet low voltage and low power requirements.

The RTL8201(L) can be used as a Network Interface Adapter, MAU, CNR, ACR, Ethernet Hub, Ethernet Switch. Additionally, it can be used in any embedded system with an Ethernet MAC that needs a twisted pair physical connection.

### 3. Block Diagram

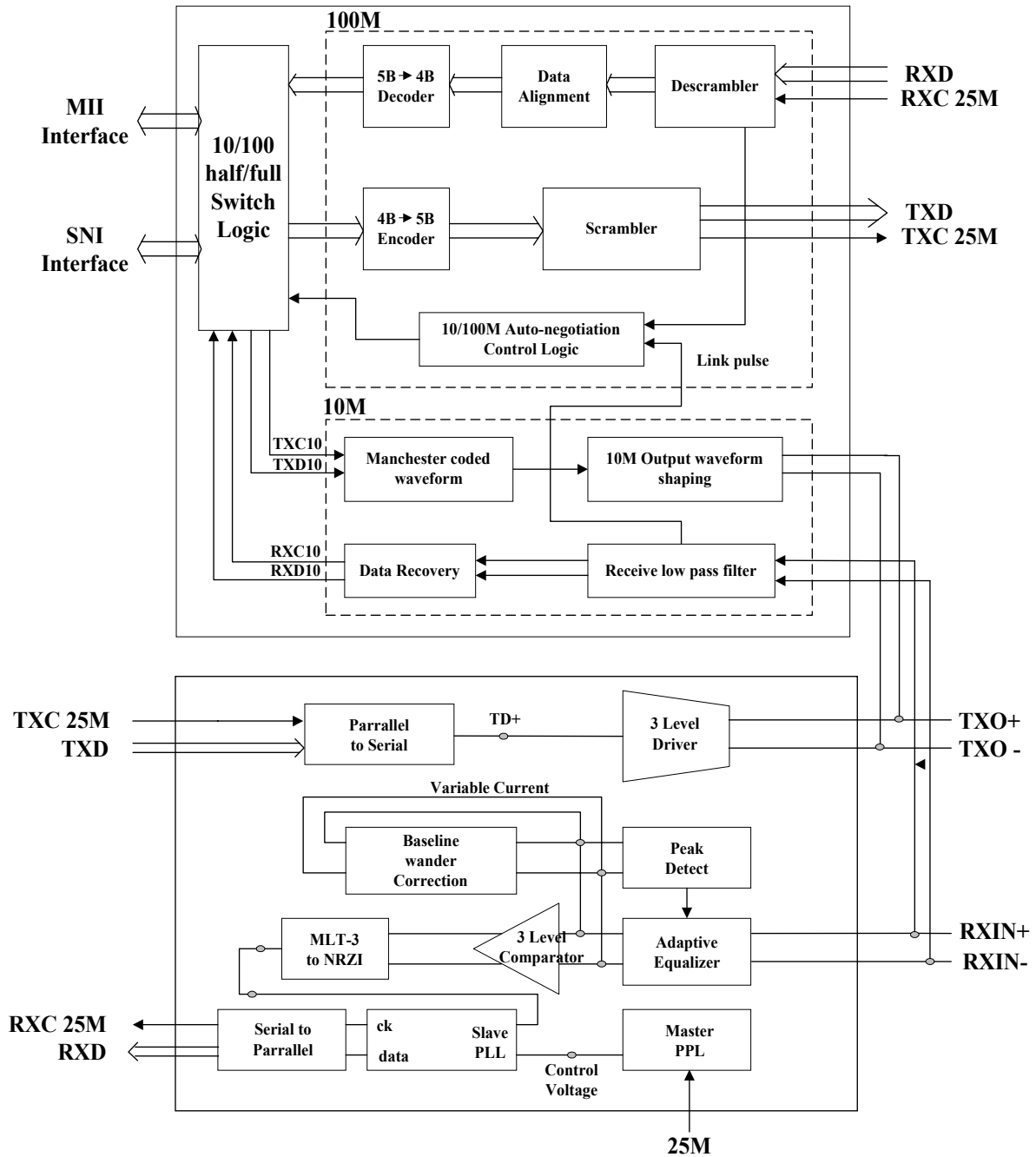

## 4. Pin Assignments

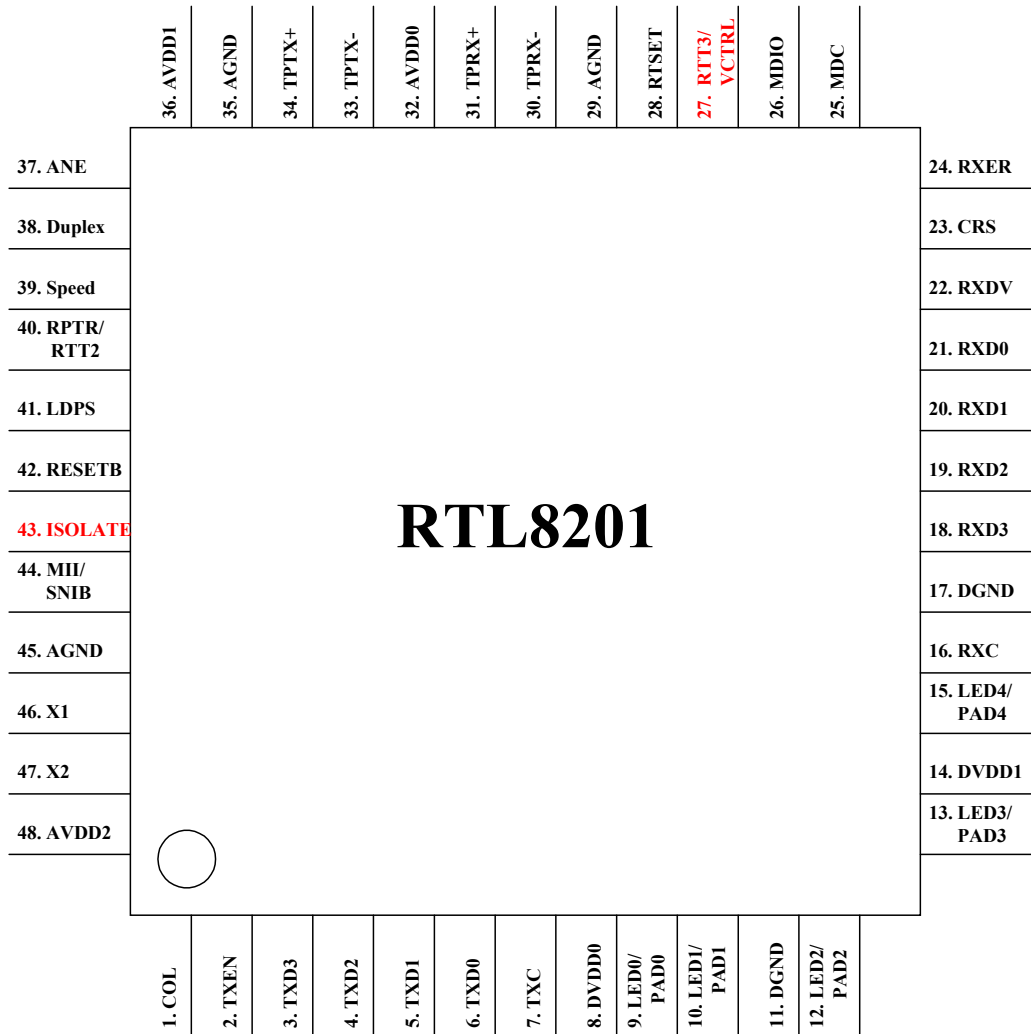

## 5. Pin Description

### 5.1 100 Mbps MII & PCS Interface

Symbol	Type	Pin(s) No.	Description
TXC	O	7	<b>Transmit Clock:</b> This pin provides a continuous clock as a timing reference for TXD[3:0] and TXEN.
TXEN	I	2	<b>Transmit Enable:</b> The input signal indicates the presence of a valid nibble data on TXD[3:0].
TXD[3:0]	I	3, 4, 5, 6	<b>Transmit Data:</b> MAC will source TXD[0..3] synchronous with TXC when TXEN is asserted.
RXC	O	16	<b>Receive Clock:</b> This pin provides a continuous clock reference for RXDV and RXD[0..3] signals. RXC is 25MHz in the 100Mbps mode and 2.5Mhz in the 10Mbps mode.
COL	O	1	<b>Collision Detected:</b> COL is asserted high when a collision is detected on the media.
CRS	I/O	23	<b>Carrier Sense:</b> This pin's signal is asserted high if the media is not in IDEL state.
RXDV	O	22	<b>Receive Data Valid:</b> This pin's signal is asserted high when received data is present on the RXD[3:0] lines; the signal is deasserted at the end of the packet. The signal is valid on the rising of the RXC.
RXD[3:0]	O	18, 19, 20, 21	<b>Receive Data:</b> These are the four parallel receive data lines aligned on the nibble boundaries driven synchronously to the RXC for reception by the external physical unit (PHY).
RXER	O	24	<b>Receive error:</b> if any 5B decode error occurred such as invalid J/K, T/R, invalid symbol, this pin will go high
MDC	I	25	<b>Management Data Clock:</b> This pin provides a clock synchronous to MDIO, which may be asynchronous to the transmit TXC and receive RXC clocks.
MDIO	I/O	26	<b>Management Data Input/Output:</b> This pin provides the bi-directional signal used to transfer management information.

### 5.2 Serial Network Interface (SNI)

#### 10Mbps only

Symbol	Type	Pin(s) No.	Description
COL	O	1	<b>Collision Detect</b>
RXD0	O	21	<b>Received Serial Data</b>
CRS	O	23	<b>Carrier Sense</b>
RXC	O	16	<b>Receive Clock:</b> Resolved from received data
TXD0	I	6	<b>Transmit Serial Data</b>
TXC	O	7	<b>Transmit Clock:</b> Generate by PHY
TXEN	I	2	<b>Transmit Enable:</b> For MAC to indicate transmit operation

### 5.3 Clock Interface

Symbol	Type	Pin(s) No.	Description
X2	O	47	<b>25Mhz Crystal Output:</b> This pin provides the 25MHz crystal output.
X1	I	46	<b>25Mhz Crystal Input:</b> This pin provides the 25MHz crystal input.

## 5.4 100Mbps Network Interface

Symbol	Type	Pin(s) No.	Description
TPTX+	O	34	<b>Transmit Output</b>
TPTX-	O	33	
RTSET	I	28	<b>Transmit bias resistor connection:</b> This pin should be pulled to GND by a 2.0K resistor.
TPRX+	I	31	<b>Receive input</b>
TPRX-	I	30	

## 5.5 Device Configuration Interface

Symbol	Type	Pin(s) No.	Description
ISOLATE	I	43	Set high to isolate the RTL8201(L) from the MAC. This will also isolate the MDC/MDIO management interface. In this mode, the power consumption is minimum.
RPTR/RTT2	I	40	Set high to put the RTL8201(L) into repeater mode. In test mode, this pin is re-defined as RTT2.
SPEED	I	39	Set high to put the RTL8201(L) into 100Mbps operation
DUPLEX	I	38	Set high to enable full duplex
ANE	I	37	Set high to enable Auto-negotiation mode, set low to force mode
LDPS	I	41	Set high to put the RTL8201(L) into LDPS mode,
MII/SNIB/TXD5(test)	I	44	Pull high to set the RTL8201(L) into MII mode operation

## 5.6 LED Interface/PHY Address Config

Symbol	Type	Pin(s) No.	Description
LED0/PAD0	O	9	<b>Link LED</b>
LED1/PAD1	O	10	<b>Full Duplex LED</b>
LED2/PAD2	O	12	<b>Link 10/ACT LED</b>
LED3/PAD3	O	13	<b>Link 100/ACT LED</b>
LED4/PAD4	O	15	<b>Collision LED</b>

## 5.7 Reset and Test pins

Symbol	Type	Pin(s) No.	Description
RTT3/CTRL	O	27	Currently a test pin, this pin may be utilized for future functions.
RESETB	I	42	<b>RESETB:</b> Setting low to reset the chip.

## 5.8 Power and Ground pins

Symbol	Type	Pin(s) No.	Description
AVDD0	P	32	<b>Analog power:</b> 3.3V power supply for analog circuit; should be well decoupled
AVDD1	P	36	<b>Analog power:</b> 3.3V power supply for analog circuit; should be well decoupled
AVDD2	P	48	3.3V power supply for PLL, should be well decoupled and use a bead with 100ohm @ 100MHz to connect to analog power
AGND	P	29,35,45	<b>Analog Ground:</b> Should be connected to a larger GND plane
DVDD0	P	8	<b>Digital Power:</b> 3.3V power supply for digital circuit.
DVDD1	P	14	<b>Digital Power:</b> 3.3V power supply for digital circuit.
DGND	P	11,17	<b>Digital Ground:</b> Should be connected to a larger GND plane

## 6. Register Descriptions

This section will describe definitions and usage for each of the registers available in the RTL8201. The first six registers of the MII are defined by the MII specification. Other registers are defined by Realtek Semiconductor Corp. for internal use and are reserved for specific uses.

Register	Description	Default (h)
0	Basic Mode Control Register	3100
1	Basic Mode Status Register	7849
2	PHY Identifier 1 Register	0000
3	PHY Identifier 2 Register	8201
4	Auto-negotiation Advertisement Register	1E1
5	Auto-negotiation Link Partner Ability Register	80
6	Auto-negotiation Expansion Register	0

### 6.1 Register 0 Basic Mode Control

Address	Name	Description/Usage	Default/Attribute
0:<15>	Reset	<p><b>Reset:</b> This bit sets the status and control registers of the PHY in a default state. In order to reset the RTL8201L by software control, a '1' must be written to bit 15 using an MII write operation. The bit clears itself after the reset process is complete, and does not need to be cleared using a second MII write. Writes to other Control register bits will have no effect until the reset process is completed, which requires approximately 1us. Writing a '0' to this bit has no effect. Because this bit is self clearing after a few cycles from a write operation, it will return a '0' when read.</p> <p>1: Software reset 0: Normal operation</p>	0, RW
0:<14>	Loopback	<p><b>Loopback:</b> This bit enables loopback of transmit data nibbles TXD&lt;3:0&gt; to the receive data path. The RTL8201L may be placed into loopback mode by writing a '1' to bit 14. Loopback mode may be cleared either by writing a '0' to bit 14 or by resetting the chip. When this bit is read, it will return a '1' when the chip is in software-controlled loopback mode, otherwise it will return a '0'.</p> <p>1: Enable loopback 0: Normal operation</p>	0, RW
0:<13>	Spd_Set	<p><b>Speed Set:</b> This bit can set the network speed. If Auto-negotiation is enabled, this bit has no effect on speed selection. However, if Auto-negotiation is disabled by software control, the operating speed of the RTL8201L can be forced by writing the appropriate value to bit 13. Writing a '1' to this bit forces 100Base-X operation, while writing a '0' forces 10Base-T operation. When this bit is read, it returns the value of the software controlled forced speed selection only.</p> <p>1: 100Mbps 0: 10Mbps</p> <p>When 100Base-FX mode is enabled, this bit=1, and this bit is read only.</p>	1, RW

0:<12>	Auto Negotiation Enable	<p><b>Auto Negotiation Enable:</b> Auto-negotiation can be disabled by either hardware or software control. This bit can enable/disable the Nway auto-negotiation function. If the ANEN input pin is driven to a logic '0', Auto-negotiation is disabled by software control. When Auto-negotiation is disabled in this manner, writing a '1' to the same bit of the control register or resetting the chip will re-enable Auto-negotiation. Writing to this bit has no effect when Auto-negotiation has been disabled by hardware control. When read, this bit will return the value most recently written to this location, or '1' if it has not been written since the last chip reset.</p> <p>1: Enable auto-negotiation; bits 0:&lt;13&gt; and 0:&lt;8&gt; will be ignored 0: Disable auto-negotiation; bits 0:&lt;13&gt; and 0:&lt;8&gt; will determine the link speed and the data transfer mode, respectively</p> <p>When 100Base-FX mode is enabled, this bit=0, and this bit is read only.</p>	1, RW
0:<11>	Power Down	<p><b>Power Down:</b> The RTL8201L supports a low power mode which is intended to decrease power consumption. This bit turns down the power of the PHY chip including internal crystal oscillator circuit. The MDC, MDIO is still alive for accessing the MAC.</p> <p>Writing a '1' will enable power down mode, and writing a '0' will return the RTL8201L to normal operation. When read, this register will return a '1' when in power down mode, and a '0' during normal operation.</p> <p>1: Power down 0: Normal operation</p>	0, RW
0:<10>	Reserved	<b>Reserved:</b> Ignore the output of the RTL8201L when these bits are read.	
0:<9>	Restart Auto Negotiation	<p><b>Restart Auto Negotiation:</b> Bit 9 is a self-clearing bit that allows the Nway auto-negotiation process to be restarted, regardless of the current status of the Auto-negotiation state machine. In order for this bit to have an effect, Auto-negotiation must be enabled. Writing a '1' to this bit restarts Auto-negotiation while writing a '0' to this bit has no effect. When this bit is read, it will always return a '0'.</p> <p>1: Re-start auto-negotiation 0: Normal operation</p>	0, RW
0:<8>	Duplex Mode	<p><b>Duplex Mode:</b> By default, the RTL8201L powers up in half duplex mode. The chip can be forced into full duplex mode by writing a '1' to bit 8 while Auto-negotiation is disabled. Half duplex mode can be resumed either by writing a '0' to bit 8 or by resetting the chip. When Nway is enabled, this bit reflects the results of the Auto-negotiation, and is in a read only mode. When Nway is disabled, this bit can be set through the SMI, and is in a read/write mode. When 100FX is enabled, this bit can be set through the SMI or FX_DUPLEX pin and is in a read/write mode. This bit sets the duplex mode if auto negotiation is disabled (bit 0:&lt;12&gt;=0).</p> <p>1: Full duplex 0: Normal operation</p> <p>After auto negotiation completes, this bit will reflect the duplex status.</p>	1, RW
0:<7:0>	Reserved	<b>Reserved Bits:</b> All reserved MII register bits must be written as '0' at all times. Ignore the RTL8201L output when these bits are read.	



## 6.2 Register 1 Basic Mode Status

Address	Name	Description/Usage	Default/Attribute
1:<15>	100Base-T4	<b>100Base_T4:</b> The RTL8201L supports the 100Base-T4 function. If the chip is set to operate in this mode, this bit will return a '1' when read.  1: Enable 100Base-T4 support 0: Suppress 100Base-T4 support	0, RO
1:<14>	100Base_TX_FD	<b>100Base_TX_FD:</b> The RTL8201L is capable of operating in 100Base-TX full duplex mode. If the chip is set to operate in this mode, this bit will return a '1' when read.  1: Enable 100Base-TX full duplex support 0: Suppress 100Base-TX full duplex support	1, RO
1:<13>	100BASE_TX_HD	<b>100Base_TX_HD:</b> The RTL8201L is capable of operating in 100Base-TX half duplex mode. If the chip is set to operate in this mode, this bit will return a '1' when read.  1: Enable 100Base-TX half duplex support 0: Suppress 100Base-TX half duplex support	1, RO
1:<12>	10Base_T_FD	<b>10Base_T_FD:</b> The RTL8201L is capable of operating in 10Base-T full duplex mode. If the chip is set to operate in this mode, this bit will return a '1' when read.  1: Enable 10Base-T full duplex support 0: Suppress 10Base-T full duplex support	1, RO
1:<11>	10_Base_T_HD	<b>10Base_T_HD:</b> The RTL8201L is capable of operating in 10Base-T half duplex mode. If the chip is set to operate in this mode, this bit will return a '1' when read.  1: Enable 10Base-T half duplex support 0: Suppress 10Base-T half duplex support	1, RO
1:<10:6>	Reserved	<b>Reserved:</b> Ignore the output of the RTL8201L when these bits are read.	
1:<5>	Auto Negotiation Complete	<b>Auto-negotiate Complete:</b> Bit 5 will return a '1' if the Auto-negotiation process has been completed and the contents of registers 4 and 5 are valid.  1: Auto-negotiation process completed 0: Auto-negotiation process not completed	0, RO
1:<4>	Remote Fault	<b>Remote Fault:</b> The PHY will return a '1' in bit 4 when its Link Partner has signaled a far-end fault condition. When a far end fault occurs, the bit will be latched at '1' and will remain so until the register is read and the remote fault condition has been cleared.  1: Remote fault condition detected (cleared on read) 0: No remote fault condition detected  When in 100Base-FX mode, this bit means an in-band signal Far-End-Fault is detected.	0, RO
1:<3>	Auto Negotiation	<b>Auto-Negotiation Ability:</b> The RTL8201L is capable of performing IEEE Auto-negotiation, and will return a '1' when bit 4 is read, regardless of whether or not the Auto-negotiation function has been disabled.  1: Link had not been experienced fail state 0: Link had been experienced fail state	1, RO

1:<2>	Link Status	<p><b>Link Status:</b> The RTL8201L will return a '1' on bit 2 when the link state machine is in Link Pass, indicating that a valid link has been established. Otherwise, it will return '0'. When a link failure occurs after the link pass state has been entered, the Link Status bit will be latched at '0' and will remain so until the bit is read. After the bit is read, it becomes '1' if the Link Pass state has been entered again.</p> <p>1: Valid link established 0: No valid link established</p>	0, RO
1:<1>	Jabber Detect	<p><b>Jabber Detect:</b> The RTL8201L will return a '1' on bit 1 if a jabber condition has been detected. After the bit is read, or if the chip is reset, it reverts to '0'. This is for 10Base-T only.</p> <p>1: Jabber condition detected 0: No jabber condition detected</p>	0, RO
1:<0>	Extended Capability	<p><b>Extended Capability:</b> The RTL8201L supports extended capability registers, and will return a '1' when bit 0 is read. Several extended registers have been implemented in the RTL8208, and their bit functions are defined later in this section.</p> <p>1: Extended register capability 0: Basic register capability only</p>	1, RO

### 6.3. Register 2 PHY Identifier 1

The PHY Identifier Registers #1 and #2 together form a unique identifier for the PHY section of this device. The Identifier consists of a concatenation of the Organizationally Unique Identifier (OUI), the vendor's model number and the model revision number. A PHY may return a value of zero in each of the 32 bits of the PHY Identifier if desired. The PHY Identifier is intended to support network management.

Address	Name	Description/Usage	Default/Attribute
2:<15;0>	PHYID1	PHY identifier ID for software recognize RTL8201	0000, RO

### 6.4. Register 3 PHY Identifier 2

Address	Name	Description/Usage	Default/Attribute
3:<15;0>	PHYID2	PHY identifier ID for software recognize RTL8201	8201, RO

## 6.5. Register 4 Auto-negotiation Advertisement

### (ANAR)

This register contains the advertised abilities of this device as they will be transmitted to its link partner during Auto-negotiation.

Address	Name	Description/Usage	Default/Attribute
4:<15>	NP	<b>Next Page:</b> The RTL8201L does not implement the Next Page function, so bit 15 will always return a '0' when read. 0: Transmitting the primary capability data page 1: Transmitting the protocol specific data page	0, RO
4:<14>	ACK	<b>Acknowledge:</b> Because the Next Page function is not implemented, bit 14 will always return a '0' when read. 1: Acknowledge reception of link partner capability data word 0: Do not acknowledge reception	0, RO
4:<13>	RF	<b>Remote Fault:</b> Bit 13 returns a value of '1' when the RTL8201L has detected a remote fault. The RTL8201L advertises this information, but does not act upon it. 1: Advertise remote fault detection capability 0: Do not advertise remote fault detection capability	0, RW
4:<12:11>	Reserved	<b>Reserved:</b> Ignore the output of the RTL8201L when these bits are read.	
4:<10>	Pause	<b>Pause:</b> The use of this bit is independent of the negotiated data rate, medium, or link technology. Setting this bit indicates the availability of additional DTE capabilities when full duplex operation is in use. This bit is used by one MAC to communicate Pause Capability to its Link Partner and has no effect on PHY operation. 1: Flow control is supported by local node 0: Flow control is NOT supported by local node	0, RW
4:<9>	T4	<b>100Base-T4:</b> This bit advertises the ability to the Link Partner that the RTL8201L can operate in 100Base-T4 mode. Writing a '0' to this bit will suppress the transmission of this ability to the Link Partner. Resetting the chip will restore the default value. The default value is '1' and writing a '1' will set this bit to '1'. Reading this bit will return the last written value or the default value if no write has been completed since the last reset. 1: 100Base-T4 is supported by local node 0: 100Base-T4 not supported by local node	0, RO
4:<8>	TXFD	<b>100Base-TX-FD:</b> This bit advertises the ability to the Link Partner that the RTL8201L can operate in 100Base-TX full duplex mode. Writing a '0' to this bit will suppress the transmission of this ability to the Link Partner. Resetting the chip will restore the default value. The default value is '1' and writing a '1' will set this bit to '1'. Reading this bit will return the last written value or the default value if no write has been completed since the last reset. 1: 100Base-TX full duplex is supported by local node 0: 100Base-TX full duplex not supported by local node	1, RW
4:<7>	TX	<b>100Base-TX:</b> This bit advertises the ability to the Link Partner that the RTL8201L can operate in 100Base-TX half duplex mode. Writing a '0' to this bit will suppress the transmission of this ability to the Link Partner. Resetting the chip will restore the default value. The default value is '1' and writing a '1' will set this bit to '1'. Reading this bit will return the last written value or the default value if no write has been completed since the last reset. 1: 100Base-TX is supported by local node 0: 100Base-TX not supported by local node	1, RW

4:<6>	10FD	<p><b>10Base-T-FD:</b> This bit advertises the ability to the Link Partner that the RTL8201L can operate in 10Base-T full duplex mode. Writing a '0' to this bit will suppress the transmission of this ability to the Link Partner. Resetting the chip will restore the default value. The default value is '1' and writing a '1' will set this bit to '1'. Reading this bit will return the last written value or the default value if no write has been completed since the last reset.</p> <p>1: 10Base-T full duplex supported by local node 0: 10Base-T full duplex not supported by local node</p>	1, RW
4:<5>	10	<p><b>10Base-T:</b> This bit advertises the ability to the Link Partner that the RTL8201L can operate in 10Base-T half duplex mode. Writing a '0' to this bit will suppress the transmission of this ability to the Link Partner. Resetting the chip will restore the default value. The default value is '1' and writing a '1' will set this bit to '1'. Reading this bit will return the last written value or the default value if no write has been completed since the last reset.</p> <p>1: 10Base-T is supported by local node 0: 10Base-T not supported by local node</p>	1, RW
4:<4:0>	Selector	<p><b>Selector Field:</b> This field reflects the binary encoded selector supported by this node. Bits 4:0 contain a fixed value of &lt;00001&gt;, representing CSMA/CD, is specified. This indicates that the chip belongs to the 802.3 class of PHY transceivers. No other protocols are supported.</p>	<00001>, RW

## 6.6 Register 5 Auto-Negotiation Link Partner Ability

### (ANLPAR)

This register contains the advertised abilities of the Link Partner as received during Auto-negotiation. The content changes after the successful Auto-negotiation if Next-pages are supported.

Address	Name	Description/Usage	Default/Attribute
5:<15>	NP	<p><b>Next Page:</b> Bit 15 returns a value of '1' when the Link Partner implements the Next Page function and has Next Page information that it wants to transmit. However, since the RTL8201L does not implement the Next Page function, it ignores the Next Page bit, except to copy it to this register.</p> <p>0: Transmitting the primary capability data page 1: Transmitting the protocol specific data page</p>	0, RO
5:<14>	ACK	<p><b>Acknowledge:</b> Bit 14 is used by Auto-negotiation to indicate that a device has successfully received its Link Partner's Link Code Word.</p> <p>1: Link partner acknowledges reception of local node's capability data word 0: No acknowledgement</p>	0, RO
5:<13>	RF	<p><b>Remote Fault:</b> Bit 13 returns a value of '1' when the Link Partner signals that it has detected a remote fault. The RTL8201L advertises this information, but does not act upon it.</p> <p>1: Link partner is indicating a remote fault 0: Link partner does not indicate a remote fault</p>	0, RO
5:<12:11>	Reserved	<p><b>Reserved:</b> Ignore the output of the RTL8201L when these bits are read.</p>	
5:<10>	Pause	<p><b>Pause:</b> Indicates that the Link Partner pause bit is set.</p> <p>1: Flow control is supported by Link partner 0: Flow control is NOT supported by Link partner</p>	0, RO
5:<9>	T4	<p><b>100Base-T4:</b> This bit indicates that the Link Partner can support 100Base-T4 mode. This bit is cleared any time Auto-negotiation is restarted or the RTL8201L is reset.</p> <p>1: 100Base-T4 is supported by link partner 0: 100Base-T4 not supported by link partner</p>	0, RO

5:<8>	TXFD	<p><b>100Base-TX-FD:</b> This bit indicates that the Link Partner can support 100Base-TX full duplex mode. This bit is cleared any time Auto-negotiation is restarted or the RTL8201L is reset.</p> <p>1: 100Base-TX full duplex is supported by link partner 0: 100Base-TX full duplex not supported by link partner</p>	0, RO
5:<7>	TX	<p><b>100Base-TX:</b> This bit indicates that the Link Partner can support 100Base-TX half duplex mode. This bit is cleared any time Auto-negotiation is restarted or the RTL8201L is reset.</p> <p>1: 100Base-TX is supported by link partner 0: 100Base-TX not supported by link partner</p> <p>This bit will also be set after the link in 100Base is established by parallel detection and the RTL8201L Nway function is enabled but the link partner does not support Nway.</p>	1, RO
5:<6>	10FD	<p><b>10Base-T-FD:</b> This bit indicates that the Link Partner can support 10Base-T full duplex mode. This bit is cleared any time Auto-negotiation is restarted or the RTL8201L is reset.</p> <p>1: 10Base-T full duplex is supported by link partner 0: 10Base-T full duplex not supported by link partner</p>	0, RO
5:<5>	10	<p><b>10Base-T:</b> This bit indicates that the Link Partner can support 10Base-T half duplex mode. This bit is cleared any time Auto-negotiation is restarted or the RTL8201L is reset.</p> <p>1: 10Base-T is supported by link partner 0: 10Base-T not supported by link partner</p> <p>This bit will also be set after the link in 10Base is established by parallel detection and the RTL8201L Nway function is enabled but the link partner does not support Nway.</p>	0, RO
5:<4:0>	Selector	<p><b>Selector Field:</b> Bits 4:0 reflect the value of the Link Partner's selector field. These bits are cleared any time Auto-negotiation is restarted or the chip is reset, and generally reflect the value of &lt;0001&gt;, representing CSMA/CD, is specified, indicating that the Link Partner is an 802.3 device.</p>	<00000>, RO

Note that the values are only guaranteed to be valid once Auto-negotiation has successfully completed, as indicated by bit 5 of the MII Status Register.

## 6.7 Register 6 Auto-negotiation Expansion (ANER)

This register contains additional status for NWay auto-negotiation.

Address	Name	Description/Usage	Default/Attribute
6:<15:5>	Reserved	<b>Reserved:</b> Ignore the output of the RTL8201L when these bits are read. This bit is always set to 0.	
6:<4>	MLF	<b>Multiple Link Fault:</b> Status indicating if a multiple link fault has occurred. Bit 4 is a read-only bit that gets latched high when a multiple link fault occurs in the Auto-negotiation state machine. For further details, please consult the IEEE standard. The bit is reset to '0' after the register is read, or when the chip is reset.  1: Fault occurred 0: No fault occurred	0, RO
6:<3>	LP_NP_ABLE	<b>Link Partner Next Page Able:</b> Status indicating if the link partner supports Next Page negotiation. Bit 3 returns a '1' when the Link Partner has Next Page capabilities. It has the same value as bit 15 of the Link Partner Ability Register.  1: Supported 0: Not supported	0, RO
6:<2>	NP_ABLE	<b>Local Next Page Able:</b> This bit indicates if the local node is able to send additional Next Pages. The RTL8201L does not have Next Page capabilities, so it will always return a '0' when bit 2 is read.	0, RO
6:<1>	PAGE_RX	<b>Page Received:</b> This bit is set high when a new Link Code Word Page has been received from the Link Partner, checked and acknowledged. This bit is cleared when the link is lost or the chip is reset. It is automatically cleared when the auto-negotiation link partner's ability register (register 5) is read by management.	0, RO
6:<0>	LP_NW_ABLE	<b>Link Partner Auto-Negotiation Able:</b> Bit 0 returns a '1' when the Link Partner is known to have Auto-negotiation capabilities. Before any Auto-negotiation information is exchanged, or if the Link Partner does not comply with IEEE Auto-negotiation, the bit returns a value of '0'.  1: Link partner supports Nway auto-negotiation 0: Link partner does not support Nway auto-negotiation	0, RO

## 6.8 Register 16 Nway Setup (NSR)

Address	Name	Description/Usage	Default/Attribute
16:<15:12>	Reserved	Ignore the results of these bits when read.	
16:<11>	ENNWLE	1: LED4 Pin indicates linkpulse	0, RW
16:<10>	Testfun	1: Auto-neg speeds up internal timer	0, RW
16:<9>	NWLPBK	1: Set Nway to loopback mode.	0, RW
16:<8:3>	Reserved	Ignore the results of these bits when read.	
16:<2>	FLAGABD	1: Auto-neg experienced ability detect state	0, RO
16:<1>	FLAGPDF	1: Auto-neg experienced parallel detection fault state	0, RO
16:<0>	FLAGLSC	1: Auto-neg experienced link status check state	0, RO

## 6.9 Register 17 Loopback, Bypass, Receiver Error Mask (LBREMR)

Address	Name	Description/Usage	Default/Attribute
17:<15>	RPTR	Set to 1 to put the RTL8201(L) into repeater mode	0, RW
17:<14>	BP_4B5B	Assertion of this bit allows bypassing of the 4B/5B & 5B/4B encoder.	0, RW
17:<13>	BP_SCR	Assertion of this bit allows bypassing of the scrambler/descrambler.	0, RW
17:<12>	LDPS	Set to 1 to enable Link Down Power Saving mode	0, RW
17:<11>	AnalogOFF	Set to 1 to power down analog function of transmitter and receiver.	0, RW
17:<10>	Reserved	Ignore the results of this bit when read.	
17:<9:8>	LB<1:0>	LB<1:0> are register bits for loopback control as defined below: 1) 0 0 for normal mode; 2) 0 1 for PHY loopback; 3) 1 0 for twister loopback	<0, 0>, RW
17:<7>	F_Link_100	Used to logic force good link in 100Mbps for diagnostic purposes.	1, RW
17:<6:5>	Reserved	Ignore the results of these bits when read.	
17:<4>	CODE_err	Assertion of this bit causes a code error detection to be reported.	0, RW
17:<3>	PME_err	Assertion of this bit causes a pre-mature end error detection to be reported.	0, RW
17:<2>	LINK_err	Assertion of this bit causes a link error detection to be reported.	0, RW
17:<1>	PKT_err	Assertion of this bit causes a detection of packet errors due to 722 ms time-out to be reported.	0, RW
17:<0>	RWPara	Parameter access enable, set 1 to access register 20~24	0, RW

## 6.10 Register 18 RX\_ER Counter (REC)

Address	Name	Description/Usage	Default/Attribute
18:<15:0>	RXERCNT	This 16-bit counter increments by 1 for each valid packet received.	H'[0000], RW

## 6.11 Register 19 10Mbps Network Interface Configuration

Address	Name	Description/Usage	Default/Attribute
19:<15:6>	Reserved	Ignore the results of these bits when read.	
19:<5>	LD	This bit is the active low TPI link disable signal. When low TPI still transmit link pulses and TPI stays in good link state.	1, RW
19:<4:2>	Reserved	Ignore the results of these bits when read.	
19:<1>	HBEN	Heart beat enable	1, RW
19:<0>	JBEN	1: Enable jabber function 0: Disable jabber function	1, RW

## 6.12 Register 20 PHY 1\_1

Address	Name	Description/Usage	Default/Attribute
20:<15:0>	PHY1_1	PHY 1 register (functions as RTL8139C<78>)	R/W

### 6.13 Register 21 PHY 1\_2

Address	Name	Description/Usage	Default/Attribute
21:<15:0>	PHY1_2	PHY 1 register (functions as RTL8139C<78>)	R/W

### 6.13 Register 22 PHY 2

Address	Name	Description/Usage	Default/Attribute
22:<15:8>	PHY2_76	PHY2 register for cable length test (functions as RTL8139C<76>)	RO
22:<7:0>	PHY2_80	PHY2 register for PLL select (functions as RTL8139C<80>)	R/W

### 6.14 Register 23 Twister\_1

Address	Name	Description/Usage	Default/Attribute
23:<15:0>	TW_1	Twister register (functions as RTL8139C<7c>)	R/W

### 6.15 Register 24 Twister\_2

Address	Name	Description/Usage	Default/Attribute
24:<15:0>	TW_2	Twister register (functions as RTL8139C<7c>)	R/W



## 7. Functional Description

The RTL8201(L) Phyceiver is a physical layer device that integrates 10Base-T and 100Base-TX functions and some extra power manage features into a 48 pin single chip which is used in 10/100 Fast Ethernet applications. This device supports the following functions:

- MII interface with MDC/MDIO management interface to communicate with MAC
- IEEE 802.3u clause 28 Auto-Negotiation ability
- Flow control ability support to cooperate with MAC
- Speed, duplex, auto-negotiation ability configurable by hard wire or MDC/MDIO.
- Flexible LED configuration.
- 7-wire SNI(Serial Network Interface) support, works only on 10Mbps mode.
- Power Down mode support
- 4B/5B transform
- Scrambling/De-scrambling
- NRZ to NRZI, NRZI to MLT3
- Manchester Encode and Decode for 10 BaseT operation
- Clock and Data recovery
- Adaptive Equalization

### 7.1 MII and Management Interface

To set the RTL8201(L) for MII mode operation, pull MII/SNIB pin high and properly set the ANE, SPEED, and DUPLEX pins.

The MII (Media Independent Interface) is an 18-signal interface which is described in IEEE 802.3u supplying a standard interface between PHY and MAC layer. This interface operates in two frequencies – 25Mhz and 2.5Mhz to support 100Mbps/10Mbps bandwidth for both the transmit and receive function. While transmitting packets, the MAC will first assert the TXEN signal and change byte data into 4 bits nibble and pass to the PHY by TXD[0..3]. PHY will sample TXD[0..] synchronously with TXC — the transmit clock signal supplied by PHY – during the interval TXEN is asserted. While receiving a packet, the PHY will assert the RXEN signal, pass the received nibble data RXD[0..3] clocked by RXC, which is recovered from the received data. CRS and COL signals are used for collision detection and handling.

The MAC layer device can control PHY by the MDC/MDIO management interface, but for proper operation, the PHY address needs to be well configured so the management command can be delivered to the PHY. The MDC can be software generated to clock the 1 bit serial data stream to/from the MDIO to access the registers of the PHY.

In 100Base-TX mode, when decoded signal in 5B is not IDLE, the CRS signal will assert and when 5B is recognized as IDLE it will be de-asserted. In 10Base-T mode, CRS will assert when the 10M preamble been confirmed and will be de-asserted when the IDLE pattern been confirmed.

The RXDV signal will be asserted when decoded 5B are /J/K/and will be deasserted if the 5B are /T/R/or IDLE in 100Mbps mode. In 10Mbps mode, the RXDV signal is the same as the CRS signal.

The RTL8201(L) does not use the TXER signal and will not affect the transmit function.

## 7.2 Auto-negotiation and Parallel Detection

The RTL8201(L) supports IEEE 802.3u clause 28 Auto-negotiation operation which can cooperate with other transceivers supporting auto-negotiation. By this mechanism, the RTL8201(L) can auto detect the link partner's ability and determine the highest speed/duplex configuration and transmit/receive in this configuration. If the link partner does not support Auto-negotiation, then the RTL8201(L) will enable half duplex mode and enter parallel detection. The RTL8201(L) will default to transmit FLP and wait for the link partner to respond. If the RTL8201(L) receives FPL, then the auto-negotiation process will go on. If it receives NLP, then the RTL8201(L) will change to 10Mbps and half duplex mode. If it receives a 100Mbps IDLE pattern, it will change to 100Mbps and half duplex mode.

To enable the auto-negotiation mode operation on the RTL8201, pull the ANE pin high and the SPEED pin and DUX pin will enable the mode. The auto-negotiation mode can be externally disabled by pulling the ANE pin low. In this case, the SPEED pin and DUX pin will change the media configuration of the RTL8201.

Below is a list for all configurations of the ANE/SPEED/DUX pins and their operation mode.

ANE	SPEED	DUX	Operation
H	L	L	Auto-negotiation enabled: the ability field does not support 100Mbps or full duplex mode operation
H	L	H	Auto-negotiation enabled: the ability field does not support 100Mbps operation
H	H	L	Auto-negotiation enabled: the ability field does not support full duplex mode operation
H	H	H	Default setup, auto-negotiation enabled: the RTL8201(L) will support 10BaseT/100BaseTX, half/full duplex mode operation
L	L	L	Auto-negotiation disabled: forces the RTL8201(L) into 10BaseT and half duplex mode
L	L	H	Auto-negotiation disabled: forces the RTL8201(L) into 10BaseT and full duplex mode
L	H	L	Auto-negotiation disabled: forces the RTL8201(L) into 100BaseTX and half duplex mode
L	H	H	Auto-negotiation disabled: forces the RTL8201(L) into 100BaseTX and full duplex mode

## 7.3 Flow control support

The RTL8201(L) supports flow control indications. The MAC can program the MII register to indicate to the PHY that flow control is supported. When MAC supports the Flow Control mechanism, setting bit 10 of the ANAR register by MDC/MDIO interface, then the RTL8201(L) will add the ability to its N-Way ability. If the Link partner also supports Flow Control, then the RTL8201(L) can recognize the Link partner's N-Way ability by examining bit 10 of ANLPAR (register 5).

## 7.4 Hardware Configuration and Auto-negotiation

This section describes methods to configure the RTL8201(L) and set the auto-negotiation mode. This list will show the various pins and their setting to provide the desired result.

- 1) **Isolate pin:** Set high to isolate the RTL8201(L) to MAC. This will also isolate the MDC/MDIO management interface. In this mode, power consumption is minimum. Please refer to the section covering Isolation mode and Power Down mode.
- 2) **RPTR pin:** Pull high to set the RTL8201(L) into repeater mode. This pin is pulled low by default. Please refer to the section covering Repeater mode operation.
- 3) **LDPS pin:** Pull high to set the RTL8201(L) into LDPS mode. This pin is pulled low by default. Please refer to the section covering Power Down mode and Link Down Power Saving.
- 4) **MII/SNIB:** Pull high to set RTL8201(L) into MII mode operation, which is the default mode for the RTL8201. This pin pulled low will set the RTL8201(L) into SNI mode operation. When set to SNI mode, the RTL8201(L) will work at 10Mbps. Please refer to the section covering Serial Network Interface for more detail information.
- 5) **ANE pin:** Pull high to enable Auto-negotiation (default). Pull low to disable auto-negotiation and activate the parallel detection mechanism. Please refer to the section covering Auto-negotiation and Parallel Detection
- 6) **Speed pin:** When ANE is pulled high, the ability to adjust speed is setup. When ANE is pulled low, pull this pin low to force 10Mbps operation and high to force 100Mbps operation. Please refer to the section on Auto-negotiation and Parallel Detection.
- 7) **DUX pin:** When ANE is pulled high, the ability to adjust the DUX pin will be setup. When ANE is pulled low, pull this pin low to force half duplex and high to force full duplex operation. Please refer to the section covering Auto-negotiation and Parallel Detection.

## 7.5 LED and PHY Address Configuration

In order to reduce the pin count on the RTL8201, the LED pins are duplexed with the PHY address pin. Because the PHYAD strap options share the LED output pins, the external combinations required for strapping and LED usage must be considered in order to avoid contention. Specifically, when the LED outputs are used to drive LEDs directly, the active state of each output driver is dependent on the logic level sampled by the corresponding PHYAD input upon power-up/reset. For example, if a given PHYAD input is pulled low then the corresponding output will be configured as an active high driver.

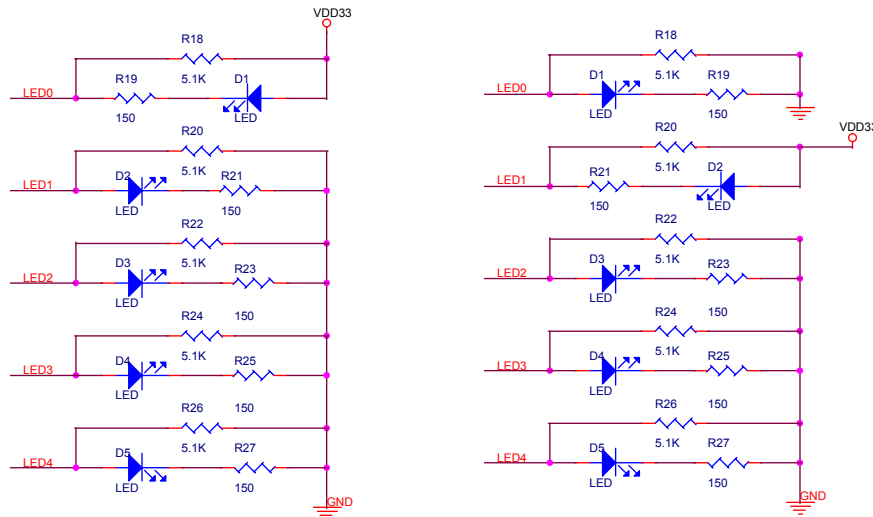

Above are examples of LED and PHY address configurations. In the left figure, the PHY address is set to (00001b=01h). In the right figure, the PHY address is set to (00010b=02h). In the above two PHY address designs, all useable LEDs have been connected. It is not necessary to utilize all LED functions when designing for the RTL8201.

The LEDs are defined in the following table.

LED	Description
LED0	Link
LED1	Full Duplex
LED2	Link 10-Activity
LED3	Link 100-Activity
LED4	Collision

## 7.6 Serial Network Interface

The RTL8201(L) also supports the traditional 7-wire serial interface to cooperate with legacy MACs or embedded systems. To setup for this mode of operation, pull the MII/SNIB pin low and by doing so, the RTL8201(L) will ignore the setup of the ANE and SPEED pins. In this mode, the RTL8201(L) will set the default to work in 10Mbps and Half-duplex mode. But the RTL8201(L) may also support full duplex mode operation if the DUPLEX pin has been pulled high.

This interface consists of 10Mbps transmit and receive clock generated by PHY, 10Mbps transmit and receive serial data, transmit enable, collision detect, and carry sense signals.

## 7.7 Power Down, Link Down, Power Saving, and Isolation Modes

The RTL8201(L) supplies 4 kinds of Power Saving mode operation. This section will discuss all four, including how to implement each mode. The first three modes are configured through software, and the fourth through hardware.

- 1) **Analog off:** Setting bit 11 of register 17 to 1 will put the RTL8201(L) into analog off state. In analog off state, the RTL8201(L) will power down all analog functions such as transmit, receive, PLL, etc. However, the internal 25Mhz crystal oscillator will not be powered down. The digital functions in this mode are still available which allows reacquisition of analog functions.
- 2) **LDPS mode:** Setting bit 12 of register 17 to 1 or pulling the LDPS pin high will put the RTL8201(L) into LDPS (Link Down Power Saving) mode. In LDPS mode, the RTL8201(L) will detect the link status to decide whether or not to turn off the transmit function. If the link is off, FLP or 100Mbps IDLE/10Mbps NLP will not be transmitted. However, some signals similar to NLP will be transmitted. Once the receiver detects any leveled signals, it will stop the signal and transmit FLP or 100Mbps IDLE/10Mbps NLP again. This may save about 60%~80% power when the link is down.
- 3) **PWD mode:** Setting bit 11 of register 0 to 1 will put the RTL8201(L) into power down mode. This is the maximum power saving mode while the RTL8201(L) is still alive. In PWD mode, the RTL8201(L) will turn off all analog/digital functions except the MDC/MDIO management interface. Therefore, if the RTL8201(L) is put into PWD mode and the MAC wants to recall the PHY, it must create the MDC/MDIO timing by itself (this is done by software).
- 4) **Isolation mode:** This mode is different from the three previous software configured power saving modes. This mode is configured by hardware pin 43. Setting pin 43 high will isolate the RTL8201(L) from the Media Access Controller (MAC) and the MDC/MDIO management interface. In this mode, power consumption is minimum.

## 7.8 Media Interface

### 7.8.1 100Base Tx/Rx

- 1) **100Base Transmit Function:** The 100Base transmit function is performed as follows: First the transmit data in 4 bits nibbles (TXD[0..3]), clocked in 25MHz (TxC) will be transformed into 5B symbol code, called 4B/5B encoding. Scrambling, serializing and conversion to 125Mhz, and NRZ to NRZI will then take place. After this process, the NRZI signal will pass to the MLT3 encoder, then to the transmit line driver. The transmitter will first assert TXEN. Before transmitting the data pattern, it will send a /J/K/ symbol (Start-of-frame delimiter), the data symbol, and finally a /T/R/ symbol known as the End-Of-Frame delimiter. The 4B/5B and the scramble process can be bypassed by setting the PHY register. For better EMI performance consideration, the seed of the scrambler is related to the PHY address. Therefore in a hub/switch environment, every RTL8201(L) will be set into a different PHY address so that they will use different scrambler seeds, which will spread the output of the MLT3 signals.
- 2) **100Base Receive Function:** The 100Base receive function is performed as follows: The received signal will first be compensated by the adaptive equalizer to make up for the signal loss due to cable attenuation and ISI. The Baseline Wander Corrector will monitor the process and dynamically apply corrections to the process of signal equalization. The PLL will then recover the timing information from the signals and form the receive clock. With this, the received signal may be sampled to form NRZI data. The next steps are the NRZI to NRZ process, unscrambling of the data, serial to parallel and 5B to 4B conversion and passing of the 4B nibble to the MII interface.

## 7.8.2 10Base Tx/Rx

- 1) **10Base Transmit Function:** The 10Base transmit function is performed as follows: The transmit 4 bits nibbles(TXD[0:3]) clocked in 2.5MHz(TXC) is first feed to parallel to serial converter, then put the 10Mbps NRZ signal to Manchester coding. The Manchester encoder converts the 10 Mbps NRZ data into a Manchester Encoded data stream for the TP transmitter and adds a start of idle pulse (SOI) at the end of the packet as specified in IEEE 802.3. Then, the encoded data stream is shaped by band- limited filter embedded in RTL8201(L) and then transmitted to TP line.
- 2) **10Base Receive function:** The 10Base receive function is performed as follows: In 10Base receive mode, The Manchester decoder in RTL8201(L) converts the Manchester encoded data stream from the TP receiver into NRZ data by decoding the data and stripping off the SOI pulse. Then, the serial NRZ data stream is converted to parallel 4 bit nibble signal(RXD[0:3]).

## 7.9 Repeater Mode Operation

Setting bit 15 of register 17 to 1 or pulling the RPTR pin high will set the RTL8201(L) into repeater mode. In repeater mode, the RTL8201(L) will assert CRS high only when receiving a packet. In NIC mode, the RTL8201(L) will assert CRS high both in transmitting and receiving packets. If using the RTL8201(L) in a repeater, please set the RTL8201(L) to Repeater mode, and if using the RTL8201(L) in a NIC or switch application, please set the default mode. NIC/Switch mode is the default setting and has the RPTR pin pulled low or bit 15 of register 17 is set to 0.

## 7.10 Reset, Power, and Transmit Bias

The RTL8201(L) can be reset by pulling the RESTB pin low for about 10ms, then pulling the pin high. It can also be reset by setting bit 15 of register 0 to 1, and then setting it back to 0. Reset will clear the registers and re-initialize them, and the media interface will first disconnect and restart the auto-negotiation/parallel detection process.

Digital power and Analog power (including PLLVDD) need to be treated differently. Analog power needs sufficient decoupling, a ferrite bead (100Ohm@100Mhz) and a capacitor to reduce the power noise.

The analog and digital Ground planes should be as large and intact as possible. If the ground plane is large enough, the analog and digital grounds can be separated, which is a more ideal configuration. However, if the total ground plane is not sufficiently large, partition of the ground plane is not a good idea. In this case, all the ground pins can be connected together to a larger single and intact ground plane.

The RTSET pin must be pulled low by a 2.0K ohm resistor with 1% accuracy to establish an accurate transmit bias, this will affect the signal quality of the transmit waveform. Keep it's circuitry away from other clock traces or transmit/receive paths to avoid signal interference.

## 8. Electrical Characteristics

### 8.1 D.C. Characteristics

#### 8.1.1. Absolute Maximum Ratings

Symbol	Conditions	Minimum	Typical	Maximum
Supply Voltage		3.0V	3.3V	3.6V
Storage Temp.		-55°C		125°C

#### 8.1.2. Operating Conditions

Symbol	Conditions	Minimum	Typical	Maximum
Vcc	Supply voltage	3.0V	3.3V	3.6V
TA	Operating Temperature	0°C		70°C

#### 8.1.3. Power Dissipation

Symbol	condition	Power consumption
P <sub>LDPS</sub>	Link down power saving mode	23 mA
P <sub>AnaOff</sub>	Analog off mode	8 mA
P <sub>PWD</sub>	Power down mode	6 mA
P <sub>Isolate</sub>	Isolate mode	5 mA
P <sub>100F</sub>	100Base full duplex	99 mA
P <sub>10F</sub>	10Base full duplex	129 mA
P <sub>10TX</sub>	10Base transmit	127 mA
P <sub>10RX</sub>	10Base receive	32 mA
P <sub>10IDLE</sub>	10Base idle	30 mA

#### 8.1.4 Supply Voltage: Vcc

Symbol	Conditions		Minimum	Typical	Maximum
V <sub>IH</sub>	Input High Vol		0.5*Vcc		Vcc+0.5V
V <sub>IL</sub>	Input Low Vol.		-0.5V		0.3*Vcc
V <sub>OH</sub>	Output High Vol.	I <sub>OH</sub> =-8mA	0.9*Vcc		Vcc
V <sub>OL</sub>	Output Low Vol.	I <sub>OL</sub> =8mA			0.1*Vcc
I <sub>OZ</sub>	Tri-state Leakage	V <sub>out</sub> =Vcc or GND	-10uA		10uA
I <sub>in</sub>	Input Current	V <sub>in</sub> =Vcc or GND	-1.0uA		1.0uA
I <sub>cc</sub>	Average Operating Supply Current	I <sub>out</sub> =0mA		200mA	

## 8.2 A.C. Characteristics

### 8.2.1 Transmission Without Collision

Shown is an example transfer of a packet from MAC to PHY.

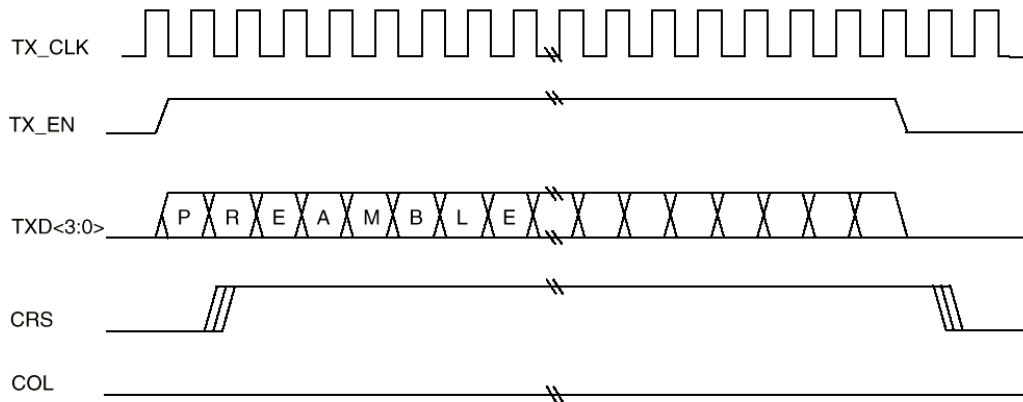

### 8.2.2 Reception Without Error

Shown is an example of transfer of a packet from PHY to MAC

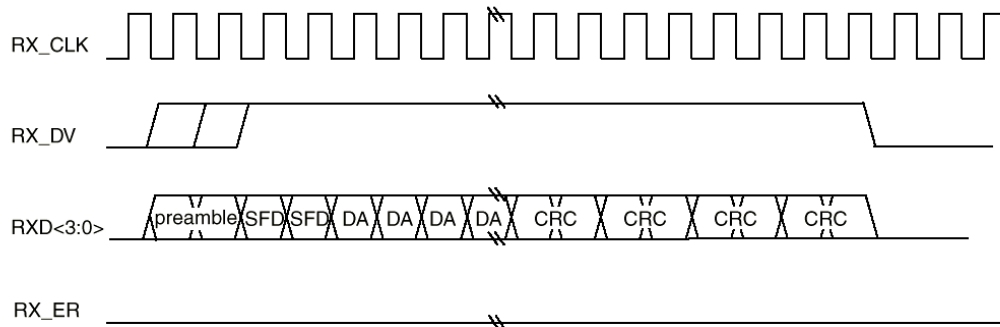



## 9. Mechanical Dimensions

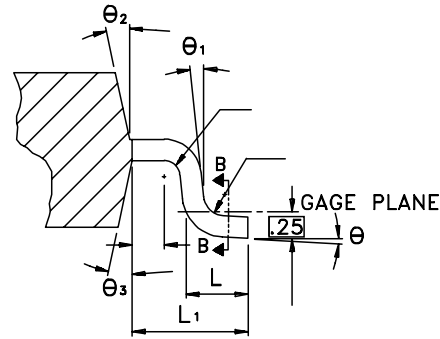
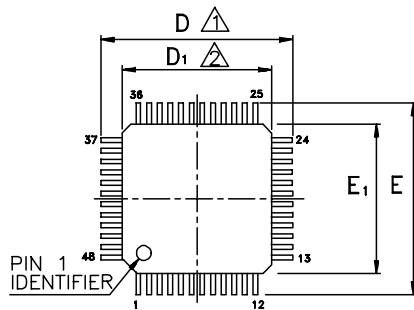

**SECTION A-A**

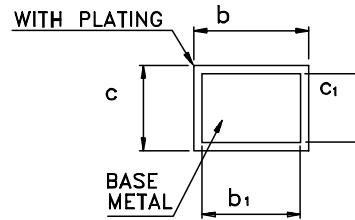
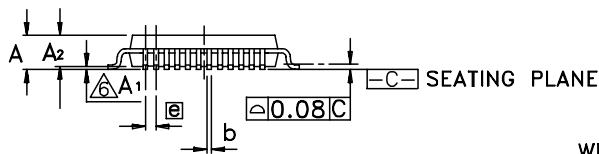

**SECTION B-B**

**Notes:**

Symbol	Dimension in inch			Dimension in mm		
	Minimal	Nominal	Maximum	Minimal	Nominal	Maximum
<b>A</b>	-	-	0.067	-	-	1.70
<b>A1</b>	0.000	0.004	0.008	0.00	0.1	0.20
<b>A2</b>	0.051	0.055	0.059	1.30	1.40	1.50
<b>b</b>	0.006	0.009	0.011	0.15	0.22	0.29
<b>b1</b>	0.006	0.008	0.010	0.15	0.20	0.25
<b>c</b>	0.004	-	0.008	0.09	-	0.20
<b>c1</b>	0.004	-	0.006	0.09	-	0.16
<b>D</b>	0.354 BSC			9.00 BSC		
<b>D1</b>	0.276 BSC			7.00 BSC		
<b>E</b>	0.354 BSC			9.00 BSC		
<b>E1</b>	0.276 BSC			7.00 BSC		
<b>e</b>	0.020 BSC			0.50 BSC		
<b>L</b>	0.016	0.024	0.031	0.40	0.60	0.80
<b>L1</b>	0.039 REF			1.00 REF		
<b>θ</b>	0°	3.5°	9°	0°	3.5°	9°
<b>θ1</b>	0°	-	-	0°	-	-
<b>θ2</b>	12° TYP			12° TYP		
<b>θ3</b>	12° TYP			12° TYP		

- To be determined at seating plane -c-
- Dimensions D1 and E1 do not include mold protrusion.  
D1 and E1 are maximum plastic body size dimensions including mold mismatch.
- Dimension b does not include dambar protrusion.  
Dambar can not be located on the lower radius of the foot.
- Exact shape of each corner is optional.
- These dimensions apply to the flat section of the lead between 0.10 mm and 0.25 mm from the lead tip.
- A1 is defined as the distance from the seating plane to the lowest point of the package body.
- Controlling dimension: millimeter.
- Reference document: JEDEC MS-026, BBC

TITLE: 48LD LQFP ( 7x7x1.4mm)			
PACKAGE OUTLINE DRAWING, FOOTPRINT 2.0mm			
LEADFRAME MATERIAL:			
APPROVE	DOC. NO.		
	VERSION	1	
	PAGE	OF	
CHECK	DWG NO.	SS048 - P1	
	DATE	Sept. 25.2000	
REALTEK SEMI-CONDUCTOR CORP.			

---

**Realtek Semiconductor Corp.****Headquarters**

1F, No. 2, Industry East Road IX, Science-based  
Industrial Park, Hsinchu, 300, Taiwan, R.O.C.

Tel : 886-3-5780211 Fax : 886-3-5776047

WWW: [www.realtek.com.tw](http://www.realtek.com.tw)

---