

# Single-Slot PCMCIA/CardBus Power Controllers

## Features

- Fully Integrated  $V_{CC}$  and  $V_{PP}$  Switching for Single-Slot PC Card™ Interface
- Low  $r_{DS(on)}$  (180-m $\Omega$  5V  $V_{CC}$  Switch and 3.3V  $V_{CC}$  Switch)
- Compatible With Controllers From Cirrus, Ricoh, O<sub>2</sub>Micro, Intel, and Texas Instruments
- 3.3V Low-Voltage Mode
- Meets PC Card Standards
- 12V Supply Can Be Disabled Except During 12V Flash Programming
- Short Circuit and Thermal Protection
- Space-Saving 16 Pin SSOP
- Compatible With 3.3V, 5V, and 12V PC Cards
- Break-Before-Make Switching

## Application

- Notebook PC
- Electronic Dictionary
- Personal Digital Assistance
- Digital still Camera

## Description

The G571 PC Card power-interface switch provides an integrated power-management solution for a single PC Cards. All of the discrete power MOSFETs, a logic section, current limiting, and thermal protection for PC Card control are combined on a single integrated circuit. The circuit allows the distribution of 3.3V, 5V, and/or 12V card power, and is compatible with many PCMCIA controllers. The current-limiting feature eliminates the need for fuses, which reduces component count and improves reliability. Current-limit reporting can help the user isolate a system fault to the PC Card.

The G571 features a 3.3V low voltage mode that allows for 3.3V switching without the need for 5V. Bias power can be derived from either the 3.3V or 5V inputs. This facilitates low-power system designs such as sleep mode and pager mode where only 3.3V is available.

End equipment for the G571 includes notebook computers, desktop computers, personal digital assistants (PDAs), digital cameras and bar-code scanners.

## Ordering Information

PART NUMBER	TEMP. RANGE	PACKAGE
G571SZ	-40°C to +85°C	SSOP-16L (150mil)
G571S1	-40°C to +85°C	SSOP-16L (209mil)

## Pin Configuration

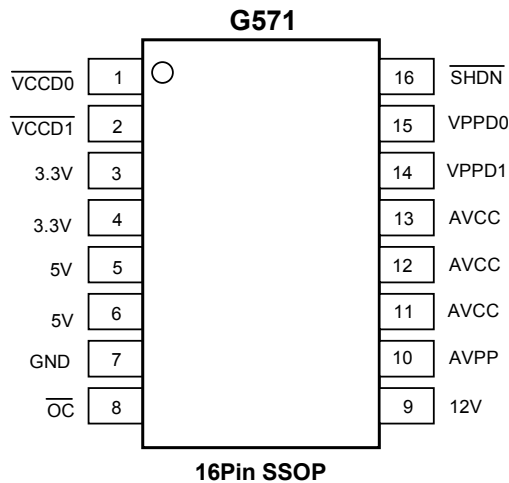

**Typical PC-card Power-distribution application**

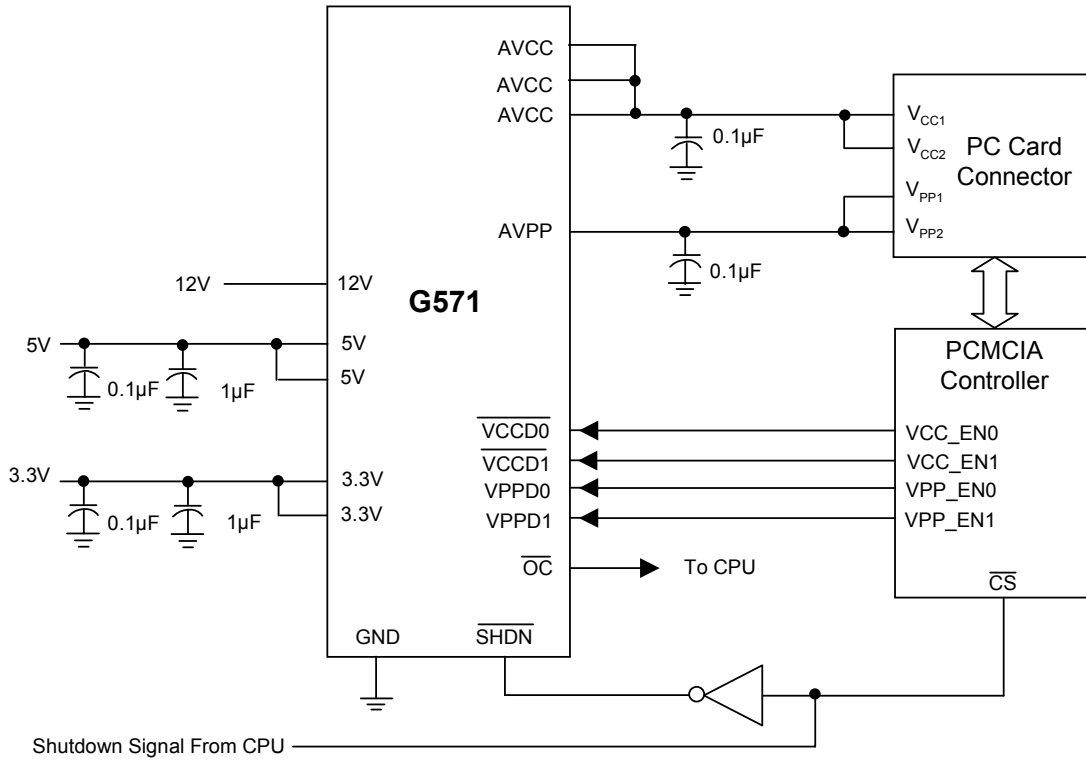

**Terminal Functions**

TERMINAL		I/O	DESCRIPTION
NAME	NO.		
3.3V	3,4	I	3.3V V <sub>CC</sub> input for card power and/or chip power if 5V is not present
5V	5,6	I	5V V <sub>CC</sub> input for card power and/or chip power
12V	9	I	12V V <sub>PP</sub> input card power
AVCC	11,12,13	O	Switched output that delivers 0V, 3.3V, 5V, or high impedance to card
AVPP	10	O	Switched output that delivers 0V, 3.3V, 5V, 12V or high impedance to card
GND	7		Ground
OC	8	O	Logic-level overcurrent reporting output that goes low when an overcurrent condition exists
SHDN	16	I	Logic input that shuts down the G571 and sets all power outputs to high-impedance state
VCCD0	1	I	Logic input that controls voltage of AVCC (see control-logic table)
VCCD1	2	I	Logic input that controls voltage of AVCC (see control-logic table)
VPPD0	15	I	Logic input that controls voltage of AVPP (see control-logic table)
VPPD1	14	I	Logic input that controls voltage of AVPP (see control-logic table)

## Absolute Maximum Ratings Over Operating Free-Air Temperature (unless otherwise noted)\*

Input voltage range for card power:

$V_{I(5V)}$  .....-0.3V to 7V

$V_{I(3.3V)}$  ..... -0.3V to 7V

$V_{I(12V)}$  .....-0.3V to 14V

Logic input voltage.....-0.3V to 7V

Output current (each card): $I_{O(VCC)}$ .....internally limited

$I_{O(VPP)}$ .....internally limited

Operating virtual junction temperature range,  $T_J$

.....-40°C to 150°C

Operating free-air temperature range,  $T_A$

.....-40°C to 85°C

Storage temperature range,  $T_{STG}$

.....-55°C to 150°C

Lead temperature 1.6 mm (1/16 inch) from case for

10 seconds.....260°C

Thermal resistance  $\theta_{JA}$

SSOP-16L (150mil).....178°C/W

SSOP-16L (209mil).....161°C/W

Power dissipation  $P_D$  ( $T_A \leq +25^\circ\text{C}$ )

SSOP-16L (150mil).....700mW

SSOP-16L (209mil).....775mW

ESD.....Note1

\*Stresses beyond those listed under "absolute maximum ratings" may cause permanent damage to the device. These are stress rating only, and functional operation of the device at these or any other conditions beyond those indicated under "recommended operating conditions" is not implied. Exposure to absolute-maximum-rated conditions for extended periods may affect device reliability.

Note 1: ESD (electrostatic discharge) sensitive device. Proper ESD precautions are recommended to avoid performance degradation or less of functionality.

## Recommended Operating Conditions

		MIN	MAX	UNIT
Input voltage, $V_I$	$V_{I(5V)}$	0	5.25	V
	$V_{I(3.3V)}$	0	5.25	V
	$V_{I(12V)}$	0	13.5	V
Output current	$I_{O(AVCC)}$		1.0	A
	$I_{O(AVPP)}$		150	mA
Operating virtual junction temperature, $T_J$		-40	125	°C

## Electrical Characteristics ( $T_A=25^\circ\text{C}$ )

### Power Switch

PARAMETER		TEST CONDITIONS*	MIN	TYP	MAX	UNIT
Switch resistance	5V to AVCC	$V_{I(5V)} = 5V$		130	180	m $\Omega$
	3.3V to AVCC	$V_{I(5V)} = 5V, V_{I(3.3V)} = 3.3V$		130	180	
	3.3V to AVCC	$V_{I(5V)} = 0V, V_{I(3.3V)} = 3.3V$		130	180	
	5V to AVPP	$T_J = 25^\circ\text{C}$			6	$\Omega$
	3.3V to AVPP	$T_J = 25^\circ\text{C}$			6	
	12V to AVPP	$T_J = 25^\circ\text{C}$			6	
$V_{O(AVPP)}$ Clamp low voltage		$I_{PP}$ at 10mA			0.8	V
$V_{O(AVCC)}$ Clamp low voltage		$I_{CC}$ at 10mA			0.8	V
$I_{IKG}$ Leakage current	$I_{PP}$ high-impedance State	$T_A = 25^\circ\text{C}$		1	10	$\mu\text{A}$
	$I_{CC}$ high-impedance State	$T_A = 25^\circ\text{C}$		1	10	
$I_I$ Input current	$V_{I(5V)} = 5V$	$V_{O(AVCC)}=5V, V_{O(AVPP)}=12V$		75	150	$\mu\text{A}$
	$V_{I(5V)} = 0V, V_{I(3.3V)} = 3.3V$	$V_{O(AVCC)}=3.3V, V_{O(AVPP)}=12V$		75	150	
	Shutdown mode	$V_{O(AVCC)}=V_{O(AVPP)} = \text{Hi-Z}$		1	3	
$I_{OS}$ Short-circuit Output-current Limit	$I_{O(AVCC)}$	output powered into a short to GND	0.8		2.2	A
	$I_{O(AVPP)}$		120		400	mA

\*Pulse-testing techniques maintain junction temperature close to ambient temperatures; thermal effects must be taken into account separately.

**Logic Section**

PARAMETER	TEST CONDITION*	MIN	MAX	UNIT
Logic input current			1	μA
Logic input high level		2		V
Logic input low level			0.8	V
Logic output high level	$V_{I(5V)} = 5V, I_O = 1mA$	$V_{I(5V)} - 0.4$		V
	$V_{I(5V)} = 0V, I_O = 1mA, V_{I(3.3V)} = 3.3V$	$V_{I(3.3V)} - 0.4$		V
Logic output low level	$I_O = 1mA$		0.4	V

\*Pulse-testing techniques maintain junction temperature close to ambient temperatures; thermal effects must be taken into account separately.

**Switching Characteristics \*\***

PARAMETER	TEST CONDITION	MIN	TYP	MAX	UNIT
$t_r$ Rise times, output	$V_O (AVCC)$		2.6		ms
	$V_O (AVPP)$		10		
$t_f$ Fall times, output	$V_O (AVCC)$		7.5		ms
	$V_O (AVPP)$		38		
$t_{pd}$ Propagation delay (see Figure 1)	$V_{I(VPPD0)}$ to $V_{O(AVPP)}$	$t_{on}$	14		ms
		$t_{off}$	44		
	$V_{I(\overline{VCCD1})}$ to $V_{O(AVCC)} (3.3V)$	$t_{on}$	3.2		
		$t_{off}$	17		
	$V_{I(\overline{VCCD0})}$ to $V_{O(AVCC)} (5V)$	$t_{on}$	4.4		
		$t_{off}$	20		

\*\*Switching Characteristics are with  $C_L = 147\mu F$ .

§ Refer to Parameter Measurement Information

**Parameter Measurement Information**

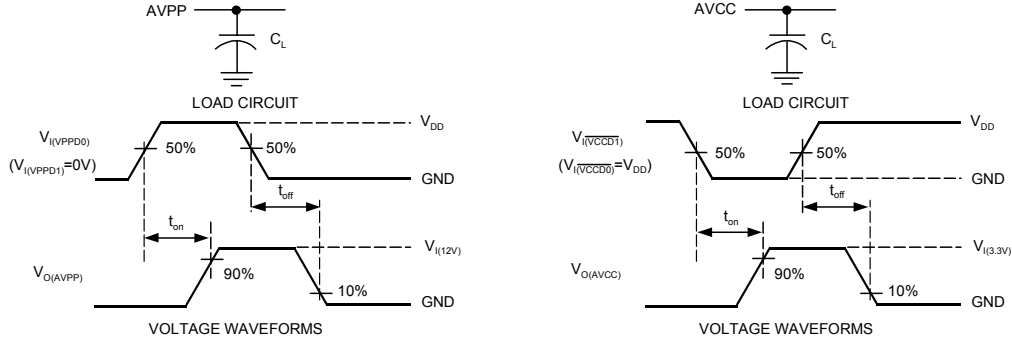

**Figure 1. Test Circuits and Voltage Waveforms**

**Table of Timing Diagrams**

	FIGURE
AVCC Propagation Delay and Rise Time With 1μF Load, 3.3V Switch	2
AVCC Propagation Delay and Fall Time With 1μF Load, 3.3V Switch	3
AVCC Propagation Delay and Rise Time With 147μF Load, 3.3V Switch	4
AVCC Propagation Delay and Fall Time With 147μF Load, 3.3V Switch	5
AVCC Propagation Delay and Rise Time With 1μF Load, 5V Switch	6
AVCC Propagation Delay and Fall Time With 1μF Load, 5V Switch	7
AVCC Propagation Delay and Rise Time With 147μF Load, 5V Switch	8
AVCC Propagation Delay and Fall Time With 147μF Load, 5V Switch	9
AVPP Propagation Delay and Rise Time With 1μF Load, 12V Switch	10
AVPP Propagation Delay and Fall Time With 1μF Load, 12V Switch	11
AVPP Propagation Delay and Rise Time With 147μF Load, 12V Switch	12
AVPP Propagation Delay and Fall Time With 147μF Load, 12V Switch	13

Parameter Measurement Information

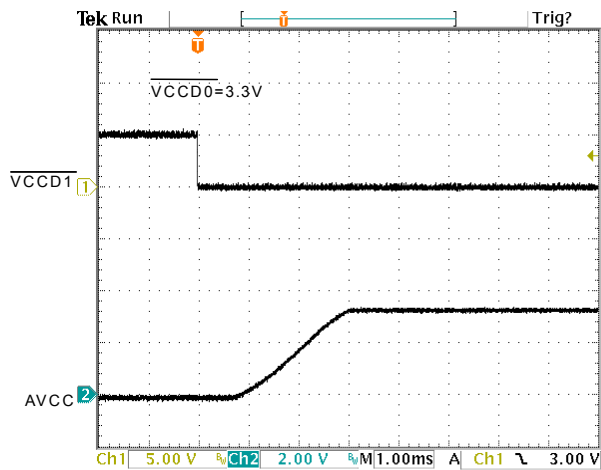

Figure 2. AVCC Propagation Delay and Rise Time With 1µF Load, 3.3V Switch

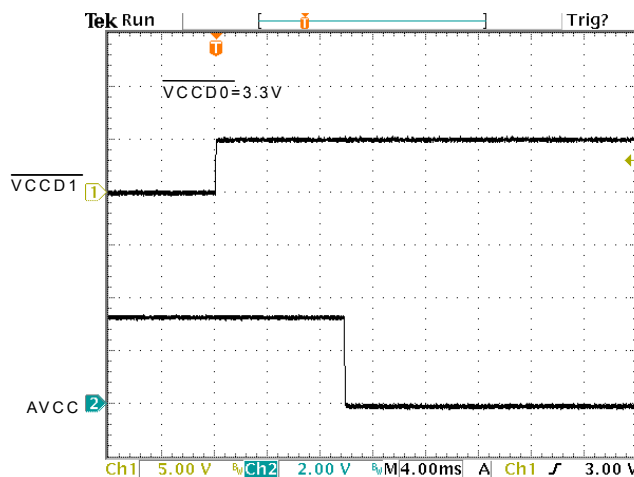

Figure 3. AVCC Propagation Delay and Fall Time With 1µF Load, 3.3V Switch

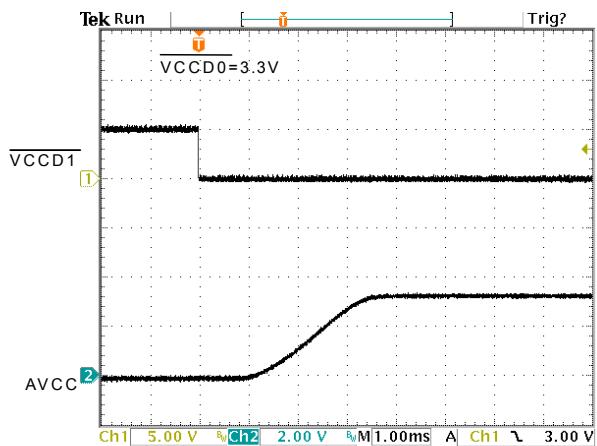

Figure 4. AVCC Propagation Delay and Rise Time With 147µF Load, 3.3V Switch

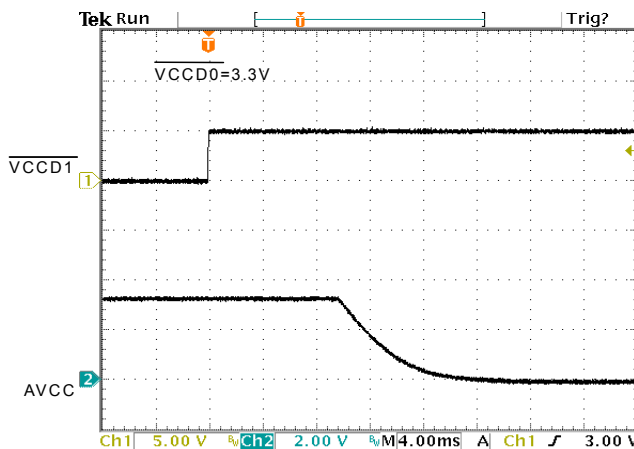

Figure 5. AVCC Propagation Delay and Fall Time With 147µF Load, 3.3V Switch

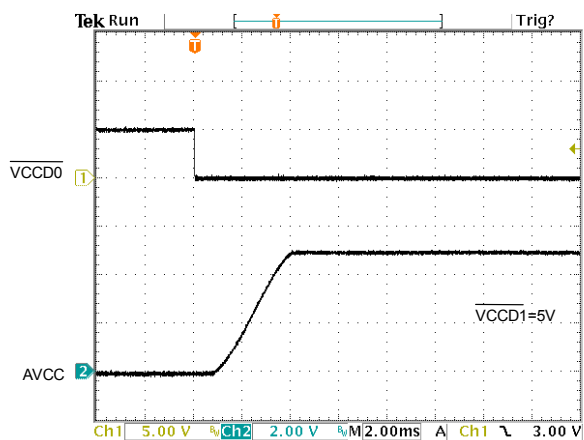

Figure 6. AVCC Propagation Delay and Rise Time With 1 $\mu$ F Load, 5V Switch

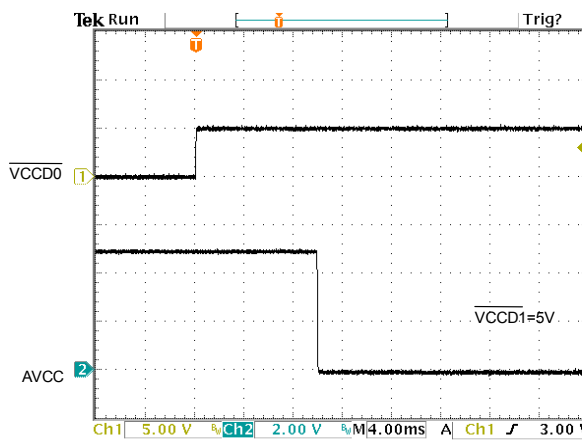

Figure 7. AVCC Propagation Delay and Fall Time With 1 $\mu$ F Load, 5V Switch

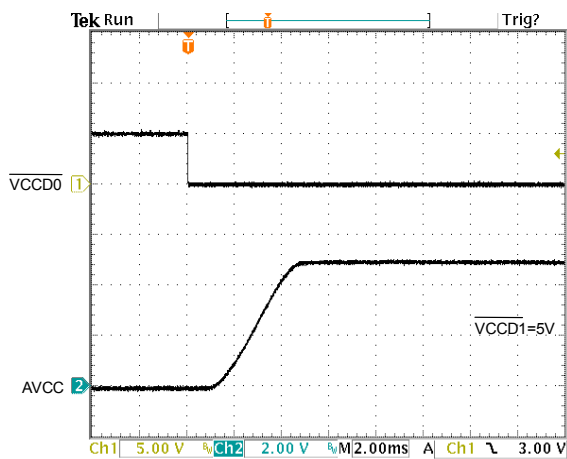

Figure 8. AVCC Propagation Delay and Rise Time With 147 $\mu$ F Load, 5V Switch

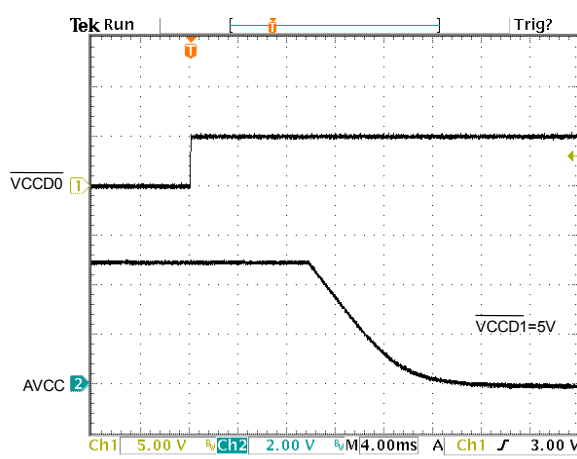

Figure 9. AVCC Propagation Delay and Fall Time With 147 $\mu$ F Load, 5V Switch

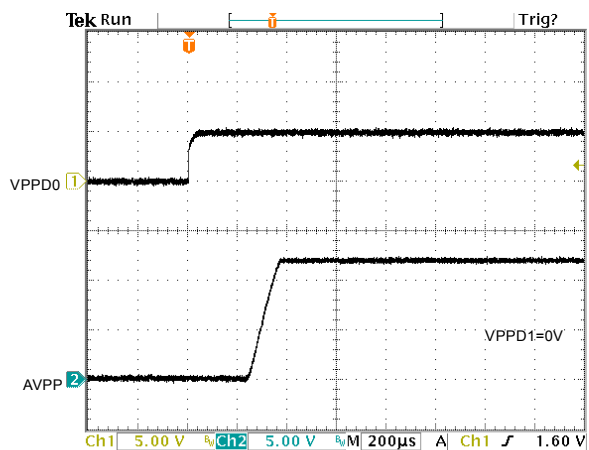

Figure 10. AVPP Propagation Delay and Rise Time With 1µF Load, 12V Switch

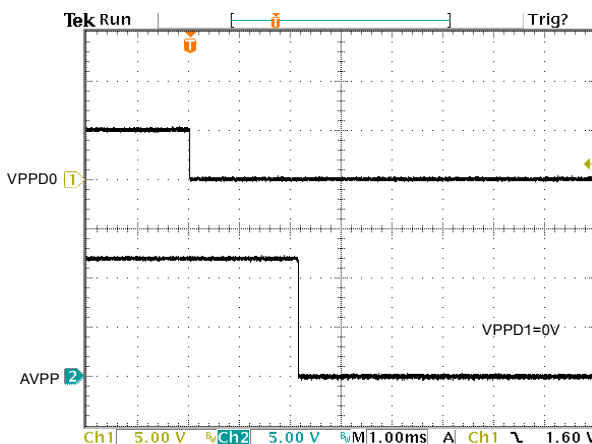

Figure 11. AVPP Propagation Delay and Fall Time With 1µF Load, 12V Switch

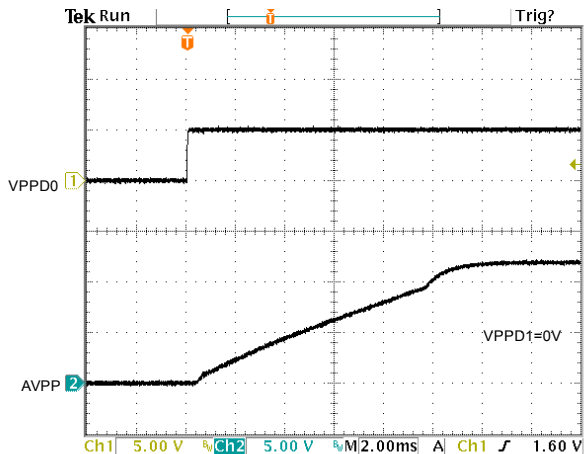

Figure 12. AVPP Propagation Delay and Rise Time With 147µF Load, 12V Switch

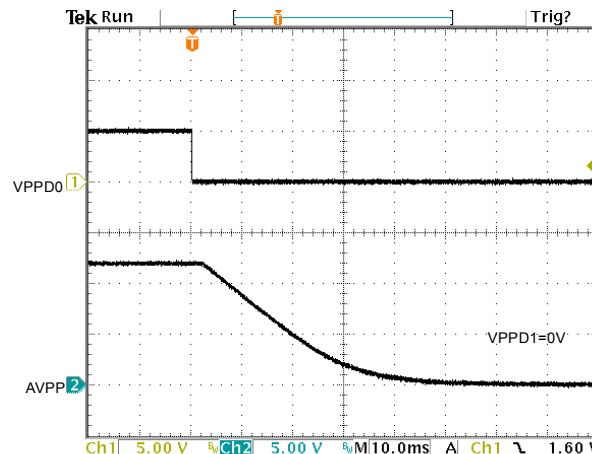

Figure 13. AVPP Propagation Delay and Fall Time With 147µF Load, 12V Switch

## Application Information

### Overview

PC Cards were initially introduced as a means to add EEPROM (flash memory) to portable computers with limited onboard memory. The idea of add-in cards quickly took hold; modems, wireless LANs, Global Positioning Satellite (GPS) systems, multimedia, and hard-disk versions were soon available. As the number of PC Card applications grew, the engineering community quickly recognized the need for a standard to ensure compatibility across platforms. To this end, the PCMCIA (Personal Computer Memory Card International Association) was established, comprised of members from leading computer, software, PC Card, and semiconductor manufactures. One key goal was to realize the "plug and play" concept, i.e. cards and hosts from different vendors should be compatible.

### PC Card Power Specification

System compatibility also means power compatibility. The most current set of specifications (PC Card Standard) set forth by the PCMCIA committee states that power is to be transferred between the host and the card through eight of the 68 terminals of the PC Card connectors. This power interface consists of two  $V_{CC}$ , two  $V_{PP}$ , and four ground terminals. Multiple  $V_{CC}$  and ground terminals minimize connector-terminal and line resistance. The two  $V_{PP}$  terminals were originally specified as separate signals but are commonly tied together in the host to form a single node to minimize voltage losses. Card primary power is supplied through the  $V_{CC}$  terminals; flash-memory programming and erase voltage is supplied through the  $V_{PP}$  terminals.

### Designing for Voltage Regulation

The current PCMCIA specification for output voltage regulation of the 5V output is 5% (250mV). In a typical PC power-system design, the power supply will have an output voltage regulation ( $V_{PS(reg)}$ ) of 2% (100mV). Also, a voltage drop from the power supply to the PC Card will result from resistive losses ( $V_{PCB}$ ) in the PCB traces and the PCMCIA connector. A typical design would limit the total of these resistive losses to less than 1% (50mV) of the output voltage. Therefore, the allowable voltage drop ( $V_{DS}$ ) for the G571 would be the PCMCIA voltage regulation less the power supply regulation and less the PCB and connector resistive drops:

$$V_{DS} = V_{O(reg)} - V_{PS(reg)} - V_{PCB}$$

Typically, this would leave 100mV for the allowable voltage drop across the G571. The voltage drop is the output current multiplied by the switch resistance of the G571. Therefore, the maximum output current that can be delivered to the PC Card in regulation is the allowable voltage drop across the G571 divided by the output switch resistance.

$$I_{Omax} = V_{DS} / R_{DS(on)}$$

The AVCC outputs deliver 1A continuous at 3.3V and 5.5V within regulation over the operating temperature range. Using the same equations, the PCMCIA specification for output voltage regulation of the 3.3V output is 300mV. Using the voltage drop percentages for power supply regulation (2%) and PCB resistive loss (1%), the allowable voltage drop for the 3.3V switch is 200mV. The 12V outputs (AVPP) of the G571 can deliver 150mA continuously.

### Overcurrent and overtemperature protection

PC Cards are inherently subiect to damage from mishandling. Host systems require protection against short-circuited cards that could lead to power supply or PCB trace damage. Even systems sufficiently robust to withstand a short circuit would still undergo rapid battery discharge into the damaged PC Card, resulting in a sudden loss of system power. Most hosts include fuses for protection. The reliability of fused systems is poor, and requires troubleshooting and repair, usually by the manufacturer. When fuses are blown.

The G571 uses sense FETs to check for overcurrent conditions in each of the AVCC and AVPP outputs. Unlike sense resistors or polyfuses, these FETs do not add to the series resistance of the switch; therefore voltage and power losses are reduced. Overcurrent sensing is applied to each output separately. When an overcurrent condition is detected, only the power output affected is limited; all other power outputs continue to function normally. The  $\overline{OC}$  indicator, normally a logic high, is a logic low when an overcurrent condition is detected providing for initiation of system diagnostics and/or sending a warning message to the user.

During power up, the G571 controls the rise time of the AVCC and AVPP outputs and limits the current into a faulty card or connector. If a short circuit is applied after power is established (e.g., hot insertion of a bad card), current is initially limited only by the impedance between the short and the power supply. In extreme cases, as much as 10A to 15A may flow into the short before the current limiting of the G571 engages. If the AVCC or AVPP outputs are driven below ground, the G571 may latch nondestructively in an off state, Cycling power will reestablish normal operation.

Overcurrent limiting for the AVCC outputs is designed to activate if powered up into a short in the range of 0.8A to 2.2A, typically at about 1.5A. The AVPP outputs limit from 120mA to 400mA, typically around 200mA. The protection circuitry acts by linearly limiting the current passing through the switch rather than initiating a full shutdown of the supply. Shutdown occurs only during thermal limiting.



Thermal limiting prevents destruction of the IC from overheating if the package power dissipation rating are exceeded. Thermal limiting disables power output until the device has cooled.

### **12V Supply Not Required**

Most PC Card switches use the externally supplied 12V to power gate drive and other chip functions, which require that power be present at all times. The G571 offers considerable power savings by using an internal charge pump to generate the required higher voltages from 5V input; Therefore, the external 12V supply can be disabled except when needed for flash-memory functions, thereby extending battery lifetime. Do not ground the 12V switch inputs when the 12-V input is not used. Additional power savings are realized by the G571 during a software shutdown in which quiescent current drops to a maximum of 3 $\mu$ A.

### **3.3V Low Voltage Mode**

The G571 will operate in a 3.3V low voltage mode when 3.3V is only available input voltage ( $V_{I(5V)} = 0$ ). This allows host and PC Cards to be operated in low-power 3.3V-only modes such as sleep modes or pager modes. Note that in these operation mode, the G571 will derive its bias current from the 3.3V input pin and only 3.3V can be delivered to the PC Card.

### **Voltage Transitioning Requirement**

PC Cards are migrating from 5V to 3.3V to minimize power consumption, optimize board space, and increase logic speeds. The G571 meets all combinations of power delivery as currently defined in the PCMCIA standard. The latest protocol accommodates mixed 3.3V/5V systems by first powering the card with 5V, then polling it to determine its 3.3V compatibility. The PCMCIA specification requires that the capacitors on 3.3V-compatible cards be discharged to below

0.8V before applying 3.3V power. This functions as a power reset and ensures that sensitive 3.3V circuitry is not subjected to any residual 5V charge. The G571 offer a selectable  $V_{CC}$  and  $V_{PP}$  ground state, in accordance with PCMCIA 3.3V/5V switching specifications.

### **Output Ground Switches**

PC Card specification requires that  $V_{CC}$  be discharged within 100 ms. PC Card resistance can not be relied on to provide a discharge path for voltages stored on PC Card capacitance because of possible high-impedance isolation by power-management schemes.

### **Power Supply Considerations**

The G571 has multiple pins for each of its 3.3V, and 5V power inputs and for switched  $V_{CC}$  outputs. Any individual pin can conduct the rated input or output current. Unless all pins are connected in parallel, the series resistance is significantly higher than that specified, resulting in increased voltage drops and lost power. It is recommended that all input and output power pins be paralleled for optimum operation.

To increase the noise immunity of the G571, the power supply inputs should be bypassed with a 1 $\mu$ F electrolytic or tantalum capacitor paralleled by a 0.047 $\mu$ F to 0.1 $\mu$ F ceramic capacitor. It is strongly recommended that the switched outputs be bypassed with a 0.1 $\mu$ F or larger, ceramic capacitor; doing so improves the immunity of the G571 to electrostatic discharge (ESD). Care should be taken to minimize the inductance of PCB traces between the G571 and the load. High switching currents can produce large negative voltage transients, which forward biases substrate diodes, resulting in unpredictable performance. Similarly, no pin should be taken below -0.3V.

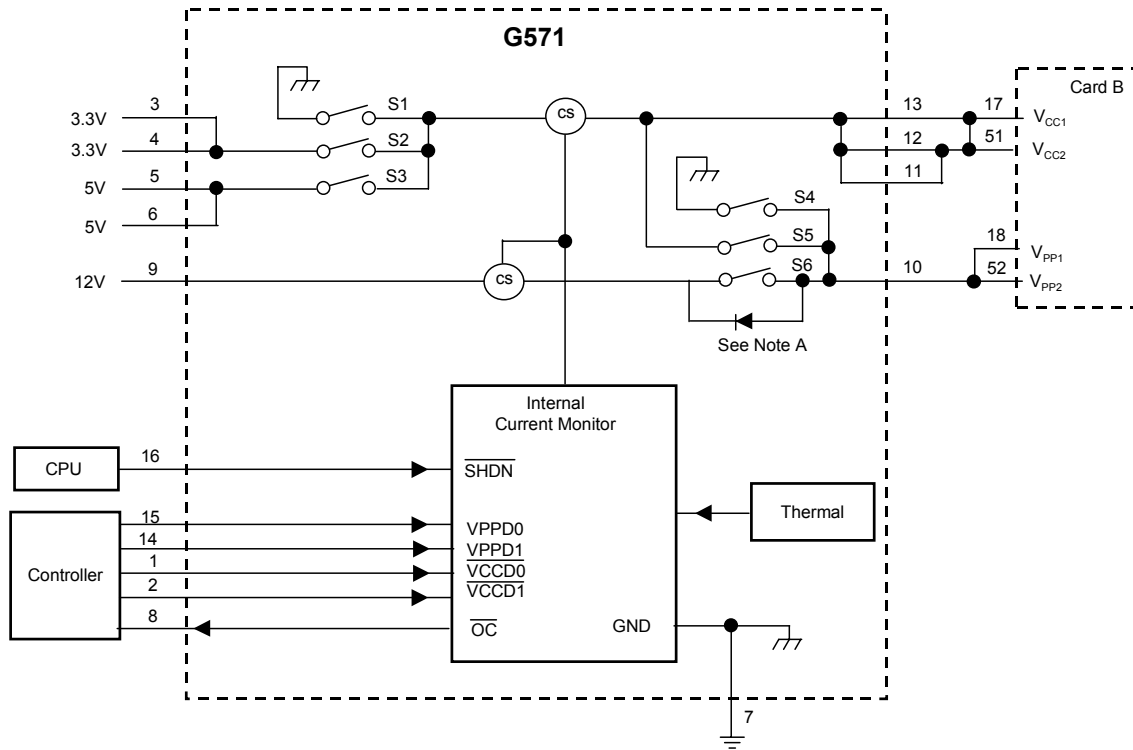

Note A: MOSFET switch S6 has a back-gate diode from the source to the drain. Unused switch inputs should never be grounded.

Figure 10. Internal Switching Matrix

### G571 Control Logic

#### AVPP

CONTROL SIGNALS			INTERNAL SWITCH SETTINGS			OUTPUT
SHDN	VPPD0	VPPD1	S4	S5	S6	AVPP
1	0	0	CLOSED	OPEN	OPEN	0V
1	0	1	OPEN	CLOSED	OPEN	AVCC*
1	1	0	OPEN	OPEN	CLOSED	VPP(12V)
1	1	1	OPEN	OPEN	OPEN	Hi-Z
0	x	x	OPEN	OPEN	OPEN	Hi-Z

\* Output depends on AVCC

#### AVCC

CONTROL SIGNALS			INTERNAL SWITCH SETTINGS			OUTPUT
SHDN	VCCD1	VCCD0	S1	S2	S3	AVCC
1	0	0	CLOSED	OPEN	OPEN	0V
1	0	1	OPEN	CLOSED	OPEN	3.3V
1	1	0	OPEN	OPEN	CLOSED	5V
1	1	1	CLOSED	OPEN	OPEN	0V
0	x	x	OPEN	OPEN	OPEN	Hi-Z

## Package Information

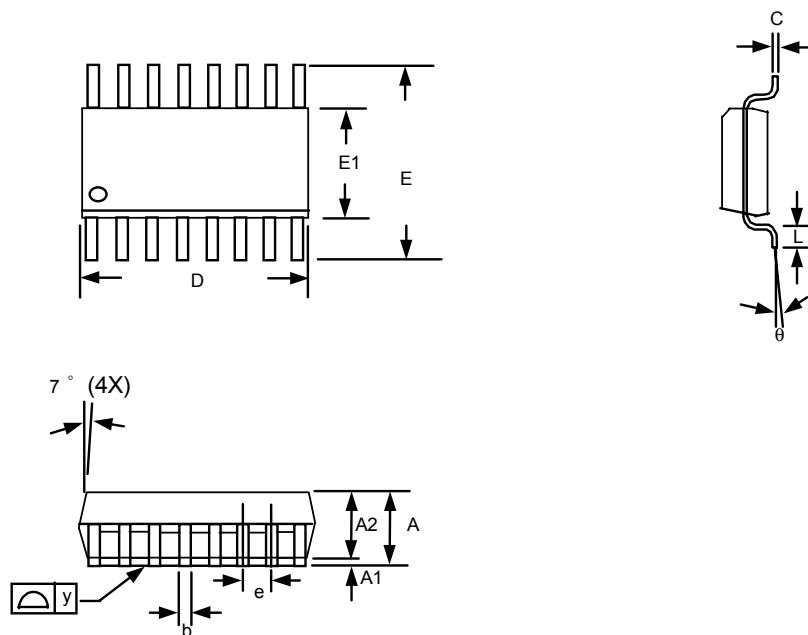

**16 Pin SSOP Package (150mil)**

**Note:**

1. Package body sizes exclude mold flash and gate burrs
2. Dimension L is measured in gage plane
3. Tolerance 0.10mm unless other wise specified
4. Controlling dimension is millimeter converted inch dimensions are not necessarily exact.

SYMBOLS	DIMENSION IN MM			DIMENSION IN INCH		
	MIN	NOM	MAX	MIN	NOM	MAX
A	1.35	1.60	1.75	0.053	0.064	0.069
A1	0.10	-----	0.25	0.004	-----	0.010
A2	-----	1.45	-----	-----	0.057	-----
b	0.20	0.25	0.30	0.008	0.010	0.012
C	0.19	-----	0.25	0.007	-----	0.010
D	4.80	-----	5.00	0.189	-----	0.197
E	5.80	-----	6.20	0.228	-----	0.244
E1	3.80	-----	4.00	0.150	-----	0.157
e	-----	0.64	-----	-----	0.025	-----
L	0.40	-----	1.27	0.016	-----	0.050
y	-----	-----	0.10	-----	-----	0.004
$\theta$	0°	-----	8°	0°	-----	8°

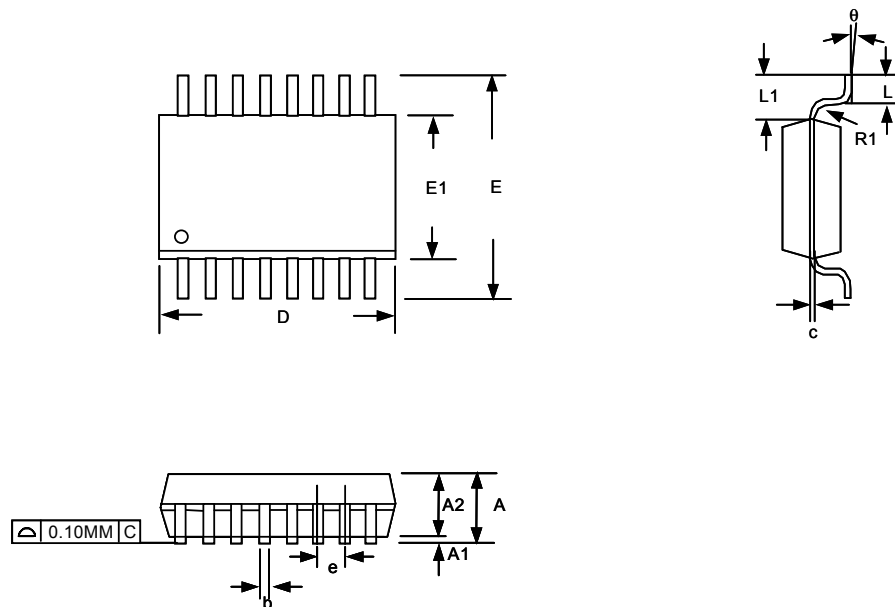

**Note:** Dimension D does not include mold protrusions or gate burrs. Mold protrusions and gate burrs shall not exceed 0.006 inch per side.

**16 Pin SSOP Package (209mil)**

SYMBOL	DIMENSION IN MM			DIMENSION IN INCH		
	MIN.	NOM.	MAX.	MIN.	NOM.	MAX.
A	-----	-----	2.00	-----	-----	0.079
A1	0.05	-----	-----	0.002	-----	-----
A2	1.65	1.75	1.85	0.065	0.069	0.073
b	0.22	0.30	0.33	0.009	0.012	0.013
c	0.09	0.15	0.21	0.004	0.006	0.008
e	0.65 BASIC			0.026 BASIC		
D	5.90	6.20	6.50	0.232	0.244	0.256
E	7.40	7.80	8.20	0.291	0.307	0.323
E1	5.00	5.30	5.60	0.197	0.209	0.220
L	0.55	0.75	0.95	0.022	0.030	0.038
L1	1.25 REF			0.049 REF		
R1	0.09	-----	-----	0.004	-----	0.04
$\theta$	0°	4°	8°	0°	4	8°
JEDEC	MO-150 (AC)					

**Taping Specification**

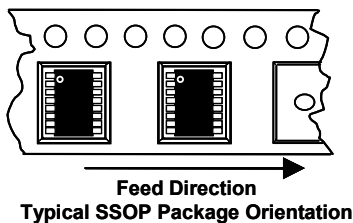

GMT Inc. does not assume any responsibility for use of any circuitry described, no circuit patent licenses are implied and GMT Inc. reserves the right at any time without notice to change said circuitry and specifications.