

Surface Mount

Power Splitter/Combiner

BP2G

2 Way-0° 50Ω 1420 to 1660 MHz



CASE STYLE: XX211
PRICE:\$0.96 ea. QTY (25)

Maximum Ratings

Operating Temperature	-40°C to 85°C
Storage Temperature	-65°C to 150°C
Power Input (as a splitter)	1.5W max.
Internal Dissipation	0.375W max.

Pin Connections

SUM PORT	2
PORT 1	8
PORT 2	5
GROUND	1,3,4,6,7

Outline Drawing

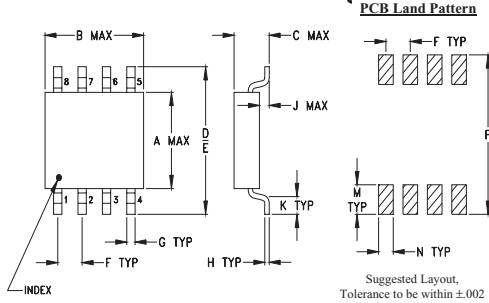

Outline Dimensions (inch/mm)

A	B	C	D	E	F	G
.163	.210	.077	.250	.220	.050	.017
4.14	5.33	1.96	6.35	5.59	1.27	0.43

H	J	K	M	N	P	wt
.009	.025	.030	.050	.030	.270	grams
0.23	0.64	0.76	1.27	0.76	6.86	0.10

Demo Board MCL P/N: TB-37 Suggested PCB Layout (PL-053)

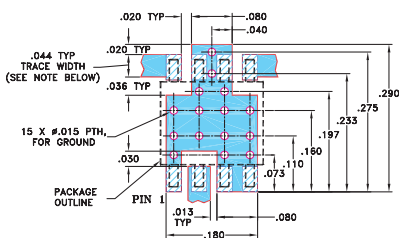

- NOTES: 1. TRACE WIDTH IS SHOWN FOR ROGERS RO4350B WITH DIELECTRIC THICKNESS 0.020" ± 0.0015". COPPER: 1/2 OZ. EACH SIDE. FOR OTHER MATERIALS TRACE WIDTH MAY NEED TO BE MODIFIED.
2. BOTTOM SIDE OF THE PCB IS CONTINUOUS GROUND PLANE.

- DENOTES PCB COPPER LAYOUT WITH SMOBC (SOLDER MASK OVER BARE COPPER)
- ▨ DENOTES COPPER LAND PATTERN FREE OF SOLDER MASK

Features

- low insertion loss, 0.6 dB typ.
- high isolation, 28 dB typ.
- excellent repeatability
- low profile
- aqueous washable

Applications

- GPS
- communications systems

Electrical Specifications

FREQ. RANGE (MHz)	ISOLATION (dB)	INSERTION LOSS (dB) ABOVE 3.0 dB	PHASE UNBALANCE (Degrees)	AMPLITUDE UNBALANCE (dB)
f_L - f_U	Typ. Min.	Typ. Max.	Max.	Max.
1420-1660	28 20*	0.6 1.0	3.0	0.2

*18 dB min. at frequencies 1500-1660 MHz

Typical Performance Data at 25°C

Frequency (MHz)	Insertion Loss (dB)		Amplitude Unbalance (dB)	Isolation (dB)	Phase Unbalance (deg.)	VSWR S	VSWR 1	VSWR 2
	S-1	S-2						
1420.00	3.69	3.77	0.08	24.22	0.18	1.12	1.08	1.06
1430.00	3.69	3.76	0.07	24.82	0.18	1.13	1.09	1.07
1450.00	3.67	3.75	0.08	26.04	0.20	1.16	1.10	1.08
1470.00	3.67	3.74	0.07	27.23	0.22	1.18	1.10	1.08
1490.00	3.66	3.73	0.07	28.29	0.25	1.21	1.11	1.09
1500.00	3.66	3.73	0.07	28.74	0.26	1.22	1.12	1.10
1520.00	3.65	3.72	0.07	29.39	0.27	1.24	1.12	1.10
1540.00	3.65	3.72	0.07	29.66	0.29	1.27	1.13	1.11
1560.00	3.65	3.72	0.07	29.50	0.32	1.29	1.14	1.12
1580.00	3.65	3.72	0.07	28.97	0.34	1.32	1.15	1.13
1590.00	3.65	3.71	0.06	28.61	0.34	1.33	1.15	1.13
1610.00	3.65	3.72	0.07	27.79	0.36	1.35	1.16	1.14
1630.00	3.66	3.72	0.06	26.94	0.35	1.37	1.17	1.15
1650.00	3.66	3.72	0.06	26.12	0.35	1.40	1.17	1.15
1660.00	3.66	3.72	0.06	25.72	0.36	1.41	1.18	1.16

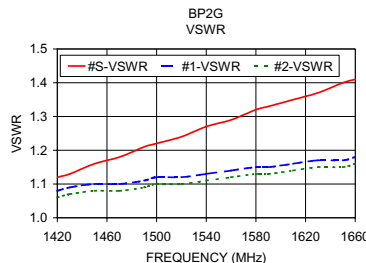
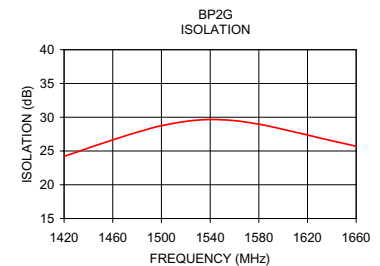
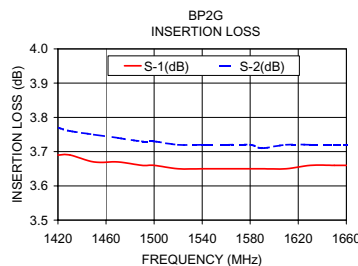

electrical schematic

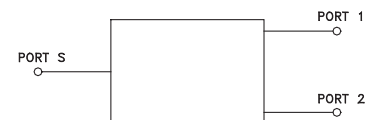

ESD Rating

Human Body Model (HBM): Class 1A (250 v to <500 v) in accordance with ANSI/ESD STM 5.1 - 2001
Machine Model (MM): Class M1 (< 100 v) in accordance with ANSI/ESD STM 5.2 - 1999 (pass 50V)



minicircuits.com

P.O. Box 350166, Brooklyn, New York 11235-0003 (718) 934-4500 Fax (718) 332-4661 For detailed performance specs & shopping online see Mini-Circuits web site

The Design Engineers Search Engine Provides ACTUAL Data Instantly From MINI-CIRCUITS At: www.minicircuits.com

IF/RF MICROWAVE COMPONENTS

REV. C
M109952
BP2G
JS/TD/CP/AM
090129