

3,622" x 3,622" x 1,496" 92 x 92 x 38 mm

113XN

**ETRI**<sup>®</sup>

AC Axial Fans

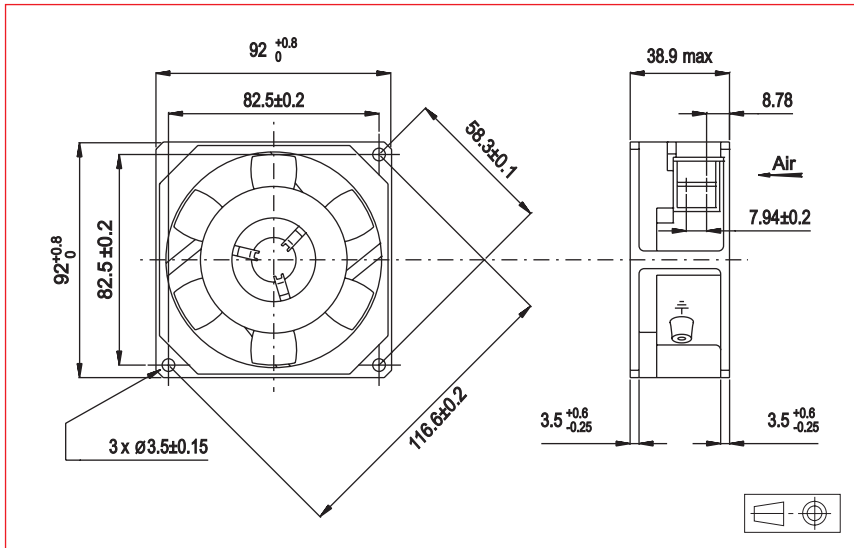

Approvals



Life expectancy

L-10 LIFE AT 40°C:  
80 000 hours

AC Motor

Electrical protection: impedance protected  
Housing material: zamak  
Impeller material: plastic UL 94 VO  
Weight: 615 g  
Bearing system: ball bearings

Available with:

- Flying leads

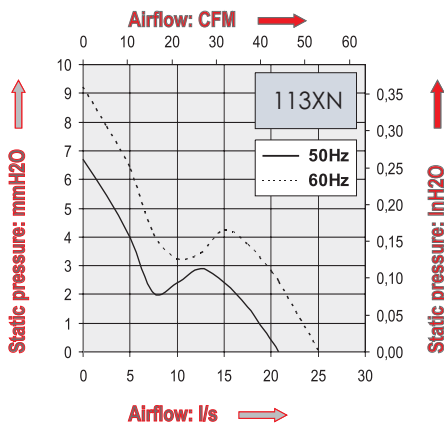

Part Number	Nominal voltage	Airflow	Noise level	Nominal speed	Frequency	Phases	Capacitor	Input Power	Nominal current	Starting current	Connection type		Operating temperature	
	V	l/s	dB(A)	RPM	Hz		µF	W	mA	mA	Leads	Terminals	Min.°C	Max.°C
113XN0182000	115	21	36	2850	50	1		10	140	270		X	-10	70
		25	41	3300	60	1		9	115	220		X	-10	70
113XN0181000	208-240	21	36	2850	50	1		12	85	160		X	-10	70
		25	41	3300	60	1		11	75	140		X	-10	70

Additional versions:

Salt spray protected - shock and vibration protected - marine specifications - wide temperature range  
IP54: consult factory

Accessories:

Refer to Accessories leaflet