

# P4C168, P4C169, P4C170 ULTRA HIGH SPEED 4K x 4 STATIC CMOS RAMS

## FEATURES

- Full CMOS, 6T Cell
- High Speed (Equal Access and Cycle Times)
  - 12/15/20/25ns (Commercial)
  - 20/25/35ns (P4C168 Military)
- Low Power Operation (Commercial)
  - 715 mW Active
  - 193 mW Standby (TTL Input) P4C168
  - 83 mW Standby (CMOS Input) P4C168
- Single 5V±10% Power Supply
- Fully TTL Compatible, Common I/O Ports
- Three Options
  - P4C168 Low Power Standby Mode
  - P4C169 Fast Chip Select Control
  - P4C170 Fast Chip Select, Output Enable Controls
- Standard Pinout (JEDEC Approved)
  - P4C168: 20-pin DIP, SOJ and SOIC
  - P4C169: 20-pin DIP and SOIC
  - P4C170: 22-pin DIP

## DESCRIPTION

The P4C168, P4C169 and P4C170 are a family of 16,384-bit ultra high-speed static RAMs organized as 4K x 4. All three devices have common input/output ports. The P4C168 enters the standby mode when the chip enable (CE) control goes high; with CMOS input levels, power consumption is only 83mW in this mode. Both the P4C169 and the P4C170 offer a fast chip select access time that is only 67% of the address access time. In addition, the P4C170 includes an output enable (OE) control to eliminate data bus contention. The RAMs operate from a single 5V ± 10% tolerance power supply.

Access times as fast as 12 nanoseconds are available, permitting greatly enhanced system operating speeds. CMOS is used to reduce power consumption to a low 715 mW active, 193 mW standby.

The P4C168 and P4C169 are available in 20-pin (P4C170 in 22-pin) 300 mil DIP packages providing excellent board level densities. The P4C168 is also available in 20-pin 300 mil SOIC and SOJ packages.

The P4C169 is also available in a 20-pin 300 mil SOIC package. The P4C170 is also available in a 22-pin 300 mil SOJ package.

## FUNCTIONAL BLOCK DIAGRAM

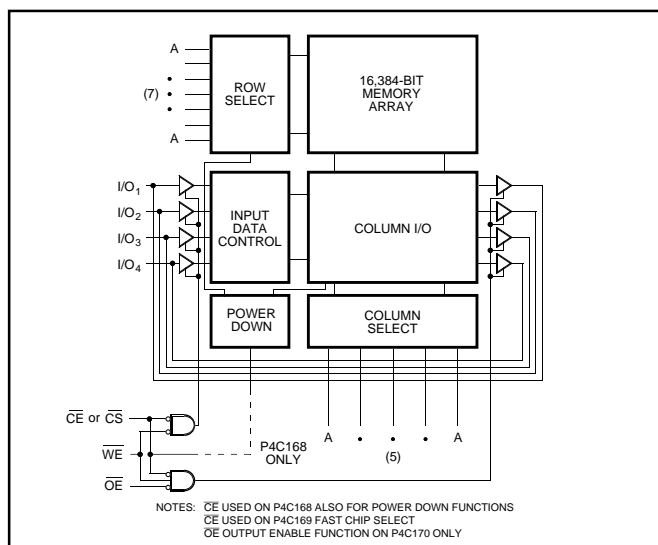

## PIN CONFIGURATIONS

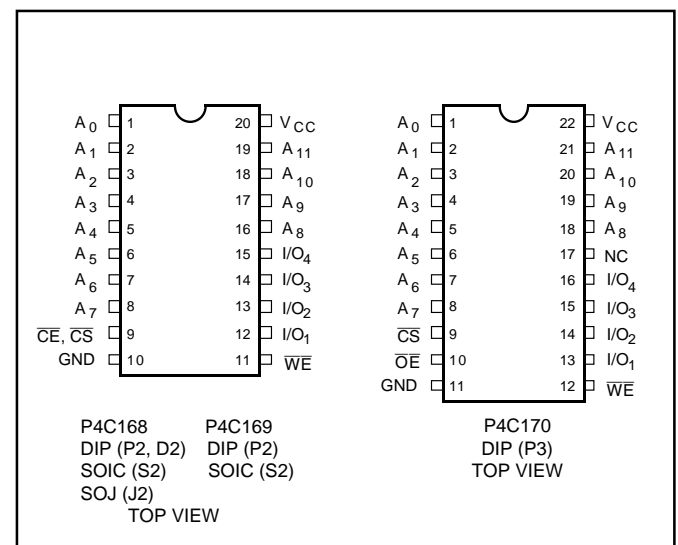

## MAXIMUM RATINGS<sup>(1)</sup>

Symbol	Parameter	Value	Unit
$V_{CC}$	Power Supply Pin with Respect to GND	-0.5 to +7	V
$V_{TERM}$	Terminal Voltage with Respect to GND (up to 7.0V)	-0.5 to $V_{CC} + 0.5$	V
$T_A$	Operating Temperature	-55 to +125	°C

Symbol	Parameter	Value	Unit
$T_{BIAS}$	Temperature Under Bias	-55 to +125	°C
$T_{STG}$	Storage Temperature	-65 to +150	°C
$P_T$	Power Dissipation	1.0	W
$I_{OUT}$	DC Output Current	50	mA

## RECOMMENDED OPERATING CONDITIONS

Grade <sup>(2)</sup>	Ambient Temp	Gnd	$V_{CC}$
Commercial	0°C to 70°C	0V	5.0V ± 10%
Military	-55°C to +125°C	0V	5.0V ± 10%

## CAPACITANCES<sup>(4)</sup>

( $V_{CC} = 5.0V$ ,  $T_A = 25°C$ ,  $f = 1.0MHz$ )

Symbol	Parameter	Conditions	Typ.	Unit
$C_{IN}$	Input Capacitance	$V_{IN} = 0V$	5	pF
$C_{OUT}$	Output Capacitance	$V_{OUT} = 0V$	7	pF

## DC ELECTRICAL CHARACTERISTICS

Symbol	Parameter	Test Conditions	P4C168/169/170		Unit
			Min	Max	
$V_{IH}$	Input High Voltage		2.2	$V_{CC} + 0.5$	V
$V_{IL}$	Input Low Voltage		-0.5(3)	0.8	V
$V_{HC}$	CMOS Input High Voltage		$V_{CC} - 0.2$	$V_{CC} + 0.5$	V
$V_{LC}$	CMOS Input Low Voltage		-0.5(3)	0.2	V
$V_{CD}$	Input Clamp Diode Voltage	$V_{CC} = \text{Min.}, I_{IN} = -18 \text{ mA}$		-1.2	V
$V_{OL}$	Output Low Voltage (TTL Load)	$I_{OL} = +8 \text{ mA}, V_{CC} = \text{Min.}$		0.4	V
$V_{OLC}$	Output Low Voltage (CMOS Load)	$I_{OLC} = +100 \mu\text{A}, V_{CC} = \text{Min.}$		0.2	V
$V_{OH}$	Output High Voltage (TTL Load)	$I_{OH} = -4 \text{ mA}, V_{CC} = \text{Min.}$	2.4		V
$V_{OHC}$	Output High Voltage (CMOS Load)	$I_{OHC} = -100 \mu\text{A}, V_{CC} = \text{Min.}$	$V_{CC} - 0.2$		V
$I_{LI}$	Input Leakage Current	$V_{CC} = \text{Max.}, V_{IN} = \text{GND to } V_{CC}$	Mil. Comm'l -10 -5	+10 +5	μA
$I_{LO}$	Output Leakage Current	$V_{CC} = \text{Max.}, \overline{CS} = V_{IH}, V_{OUT} = \text{GND to } V_{CC}$	Mil. Comm'l -10 -5	+10 +5	μA
$I_{CC}$	Dynamic Operating Current	$V_{CC} = \text{Max.}, f = \text{Max.}, \text{Outputs Open}$	—	130	mA
$I_{SB}$	Standby Power Supply Current (TTL Input Levels) P4C168 only	$\overline{CE} \geq V_{IH}, V_{CC} = \text{Max.}, f = \text{Max.}, \text{Outputs Open}$	—	35	mA
$I_{SB1}$	Standby Power Supply Current (CMOS Input Levels) P4C168 only	$\overline{CE} \geq V_{HC}, V_{CC} = \text{Max.}, f = 0, V_{IN} \leq V_{LC} \text{ or } V_{IN} \geq V_{HC}$	—	15	mA

**AC CHARACTERISTICS—READ CYCLE** $(V_{CC} = 5V \pm 10\%$ , All Temperature Ranges)<sup>(2)</sup>

Sym.	Parameter	-12		-15		-20		-25		-35		Unit
		Min	Max	Min	Max	Min	Max	Min	Max	Min	Max	
$t_{RC}$	Read Cycle Time	12		15		20		25		35		ns
$t_{AA}$	Address Access Time		12		15		20		25		35	ns
$t_{AC}^{\S}$	Chip Enable Access Time		12		15		20		25		35	ns
$t_{AC}^{\ddagger}$	Chip Select Access Time		8		9		12		15		20	ns
$t_{OH}$	Output Hold from Address Change	2		2		2		2		2		ns
$t_{LZ}^{\ddagger}$	Chip Enable to Output in Low Z	2		2		2		2		2		ns
$t_{HZ}^{\dagger}$	Chip Disable to Output in High Z		6		7		9		10		15	ns
$t_{OE}^{\dagger}$	Output Enable to Data Valid		8		10		12		15		15	ns
$t_{OLZ}^{\dagger}$	Output Enable to Output in Low Z	0		0		0		0		0		ns
$t_{OHZ}^{\dagger}$	Output Disable to Output in High Z		6		7		9		11		15	ns
$t_{RCS}$	Read Command Setup Time	0		0		0		0		0		ns
$t_{RCH}$	Read Command Hold Time	0		0		0		0		0		ns
$t_{PU}^{\S}$	Chip Enable to Power Up Time	0		0		0		0		0		ns
$t_{PD}^{\S}$	Chip Disable to Power Down Time		12		15		20		25		35	ns

§ P4C168 only

† P4C170 only

‡ Chip Select/Deselect for P4C169 and P4C170

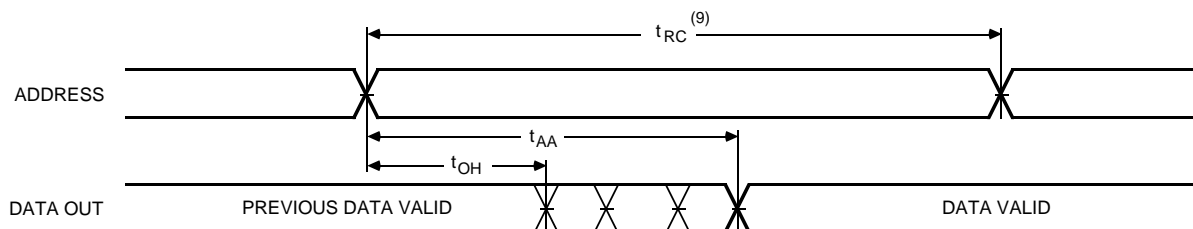
**TIMING WAVEFORM OF READ CYCLE NO. 1 (ADDRESS CONTROLLED)<sup>(5,6)</sup>****Notes:**5.  $\overline{WE}$  is HIGH for READ cycle.6.  $\overline{CE}/\overline{CS}$  and  $\overline{OE}$  are LOW for READ cycle.

**TIMING WAVEFORM OF READ CYCLE NO. 2 ( $\overline{CE}/\overline{CS}$  CONTROLLED)<sup>(5,7)</sup>**

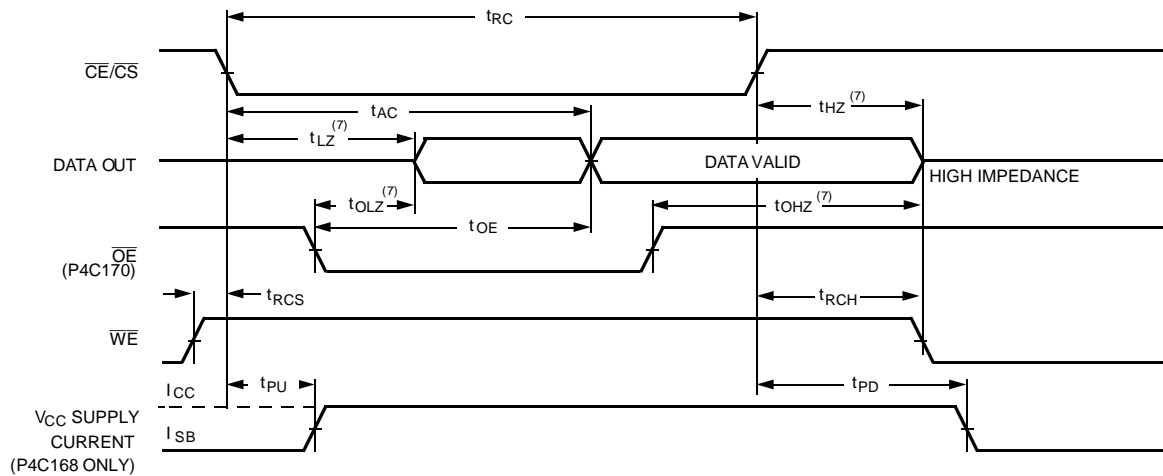

**TIMING WAVEFORM OF READ CYCLE NO. 3—P4C170 ONLY ( $\overline{OE}$  CONTROLLED)<sup>(5)</sup>**

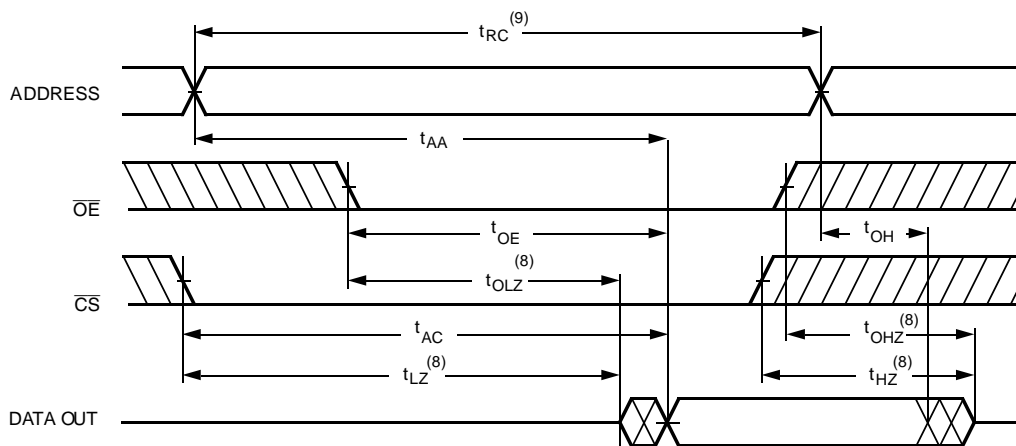

**Notes:**

- 7. ADDRESS must be valid prior to, or coincident with  $\overline{CE}/\overline{CS}$  transition low. For Fast  $\overline{CS}$ ,  $t_{AA}$  must still be met.
- 8. Transition is measured  $\pm 200\text{mV}$  from steady state voltage prior to change, with loading as specified in Figure 1.

- 9. Read Cycle Time is measured from  $t_{152105}$  valid address to the first transitioning address.

## AC ELECTRICAL CHARACTERISTICS - WRITE CYCLE

( $V_{CC} = 5V \pm 10\%$ , All Temperature Ranges)<sup>(2)</sup>

Sym.	Parameter	-12		-15		-20		-25		-35		Unit
		Min	Max	Min	Max	Min	Max	Min	Max	Min	Max	
$t_{WC}$	Write Cycle Time	12		15		18		20		35		ns
$t_{CW}$	Chip Enable Time to End of Write	12		15		18		20		30		ns
$t_{AW}$	Address Valid to End of Write	12		15		18		20		30		ns
$t_{AS}$	Address Set-up Time	0		0		0		0		0		ns
$t_{WP}$	Write Pulse Width	12		15		18		20		30		ns
$t_{AH}$	Address Hold Time	0		0		0		0		0		ns
$t_{DW}$	Data Valid to End of Write	7		8		10		10		15		ns
$t_{DH}$	Data Hold Time	0		0		0		0		0		ns
$t_{WZ}$	Write Enable to Output in High Z		4		5		7		7		13	ns
$t_{OW}$	Output Active from End of Write	0		0		0		0		0		ns

### TIMING WAVEFORM OF WRITE CYCLE NO. 1 ( $\overline{WE}$ CONTROLLED)<sup>(10)</sup>

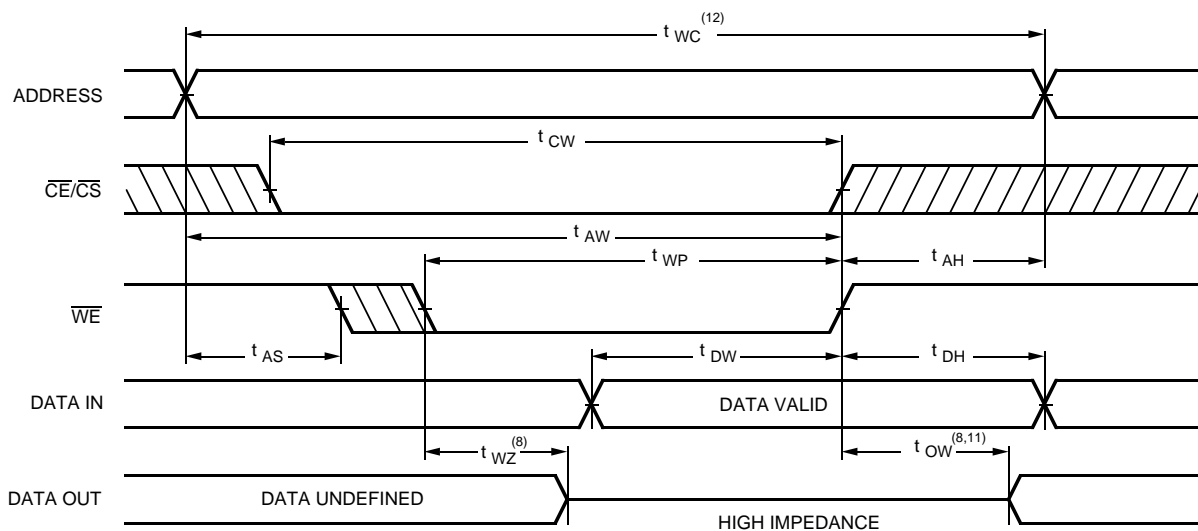

#### Notes:

10.  $\overline{CE}/\overline{CS}$  and  $\overline{WE}$  must be LOW for WRITE cycle.

11. If  $\overline{CE}/\overline{CS}$  goes HIGH simultaneously with  $\overline{WE}$  HIGH, the output remains in a high impedance state.

12. Write Cycle Time is measured from the last valid address to the first transitioning address.

### TIMING WAVEFORM OF WRITE CYCLE NO. 2 ( $\overline{CE}/\overline{CS}$ CONTROLLED)<sup>(10)</sup>

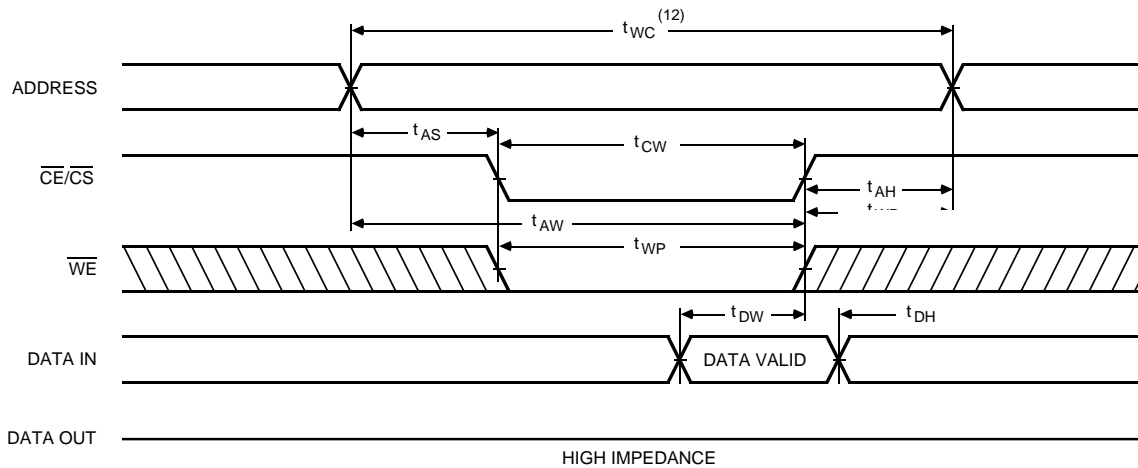

### TRUTH TABLES

P4C168 (P4C169)

Mode	$\overline{CE}$ ( $\overline{CS}$ )	$\overline{WE}$	Output
Standby (Deselect)	H	X	High Z
Read	L	H	D <sub>OUT</sub>
Write	L	L	High Z

P4C170

Mode	$\overline{CE}$	$\overline{WE}$	$\overline{OE}$	Output
Deselect	H	X	X	High Z
Read	L	H	L	D <sub>OUT</sub>
Output Inhibit	L	H	H	High Z
Write	L	L	X	High Z

### AC TEST CONDITIONS

Input Pulse Levels	GND to 3.0V
Input Rise and Fall Times	3ns
Input Timing Reference Level	1.5V
Output Timing Reference Level	1.5V
Output Load	See Figures 1 and 2

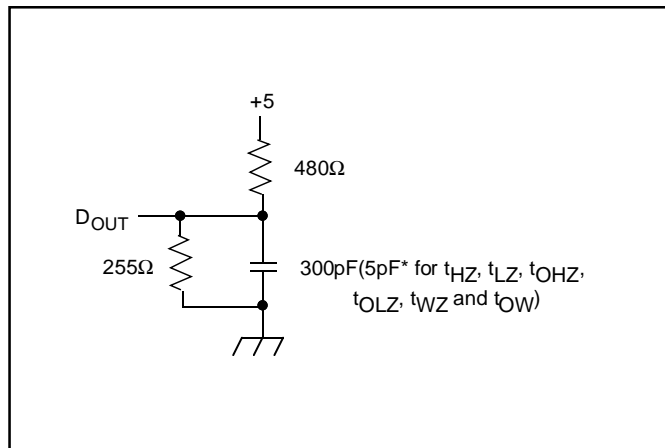

Figure 1. Output Load

\* including scope and test fixture.

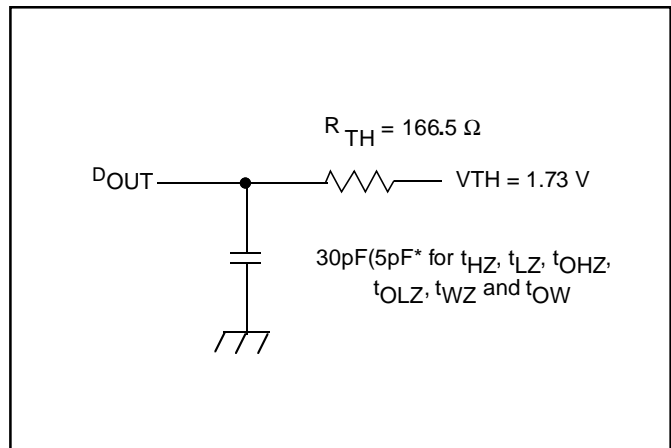

Figure 2. Thevenin Equivalent

**Note:**

Because of the ultra-high speed of the P4C168, P4C169 AND P4C170 care must be taken when testing these devices; an inadequate setup can cause a normal functioning part to be rejected as faulty. Long high-inductance leads that cause supply bounce must be avoided by bringing the V<sub>CC</sub> and ground planes directly up to the contactor fingers. A 0.01 μF

high frequency capacitor is also required between V<sub>CC</sub> and ground. To avoid signal reflections, proper termination must be used; for example, a 50Ω test environment should be terminated into a 50Ω load with 1.73V (Thevenin Voltage) at the comparator input, and a 116Ω resistor must be used in series with D<sub>OUT</sub> to match 166Ω (Thevenin Resistance).

**PACKAGE SUFFIX**

Package Suffix	Description
P	Plastic DIP, 300 mil wide standard
S	Plastic SOIC, 300 mil wide standard
J	Plastic SOJ, 300 mil wide standard
D	CERDIP, 300 mil wide standard

**TEMPERATURE RANGE SUFFIX**

Temperature Range Suffix	Description
C	Commercial Temperature Range, 0°C – +70°C.
M	Military Temperature Range, –55°C – +125°C.
MB	Mil. Temp. with MIL-STD-883D Class B compliance

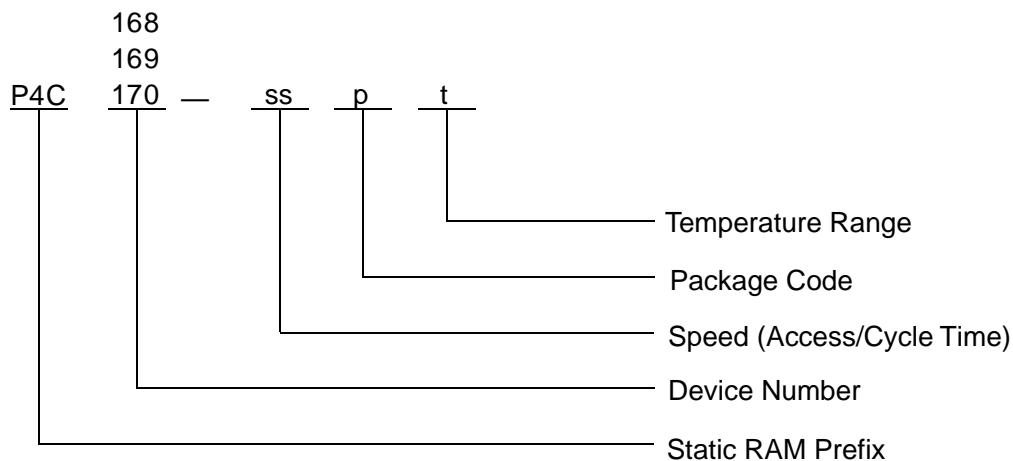
**ORDERING INFORMATION**

ss = Speed (access/cycle time in ns), e.g., 15, 20

p = Package code, i.e., P, S,D, J.

t = Temperature range, i.e., C, M, MB.

The P4C168 is also available per SMD #5962-86705

**SELECTION GUIDE**

The P4C168, P4C169 and P4C170 are available in the following temperature, speed and package options.

Temperature Range	Package	Speed (ns)				
		12	15	20	25	35
Commercial	Plastic DIP	-12PC	-15PC	-20PC	-25PC	N/A
	Plastic SOIC†	-12SC	-15SC	-20SC	-25SC	N/A
	Plastic SOJ††	-12JC	-15JC	-20JC	-25JC	N/A
Military Temp. (P4C168 only)	CERDIP	N/A	N/A	-20DM	-25DM	-35DM
Military Processed* (P4C168 only)	CERDIP	N/A	N/A	-20DMB	-25DMB	-35DMB

† P4C168 and P4C169 only.

†† P4C168

\* Military temperature range with MIL-STD-883, Class B processing.

N/A = Not available

