

# Stereo Headphone Power Amplifier

## Features

- Class AB amplifier
- High performance
- High signal-to-noise ratio
- Low distortion
- Low power consumption
- Large output voltage swing
- Excellent power supply ripple rejection
- 3.0V to 7.0V supply voltage range
- Surface-Mount package-SOP 8

## Applications

- CD-ROM
- DVD-ROM
- CD-R/W
- MP3
- Portable Stereo
- Earphone for cellular phone

## General Description

The G1401 is a stereo audio power amplifier housed in a 8-pin SOP package capable of delivering 135mW of continuous power per channel into 16Ω loads.

Amplifier gain is externally configured by means of two resistors per input channel.

The G1401 is a dual channel, low voltage, low power, performance OP amps that can be designed into a wide range of headphone driving applications, at an economical price.

## Ordering Information

PART	TEMP. RANGE	PIN-PACKAGE
G1401P1	0°C to +70°C	8 SOP

## Pin Configuration

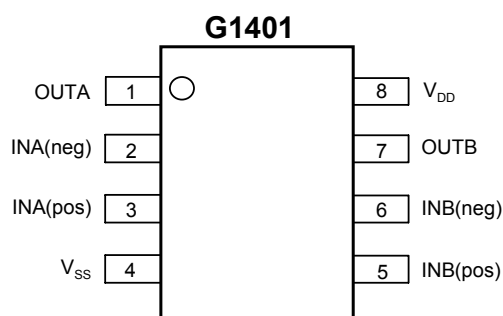

## Pinning

SYMBOL	PIN	DESCRIPTION
OUTA	1	output A
INA(neg)	2	inverting input A
INA(pos)	3	non-inverting input A
V <sub>SS</sub>	4	negative supply
INB(pos)	5	non-inverting input B
INB(neg)	6	inverting input B
OUTB	7	output B
V <sub>DD</sub>	8	positive supply

**Block Diagram**

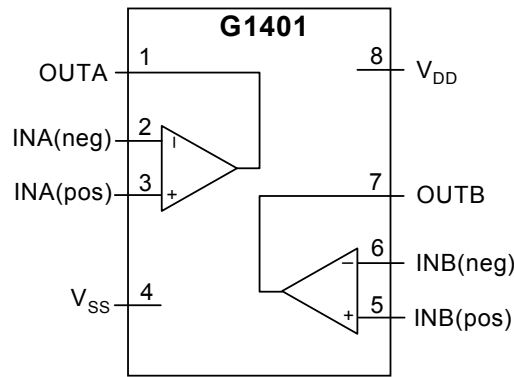

**Absolute Maximum Ratings (Note1)**

SYMBOL	PARAMETER	CONDITIONS	MIN.	MAX.	UNIT
$V_{DD}$	Supply voltage		0	7.0	V
$T_{stg}$	Storage temperature		-65	+150	°C
$T_{amb}$	Operating ambient temperature		0	+70	°C
ESD	ESD voltage	HBM	-	2	KV

**Notes:**

1. Absolute Maximum Ratings are limits beyond which damage to the device may occur.

**Thermal Characteristics**

SYMBOL	PARAMETER	VALUE	UNIT
$R_{th\ j-a}$	Thermal resistance from junction to ambient in free air SO8	210	°C/W

**Test and Application Information**

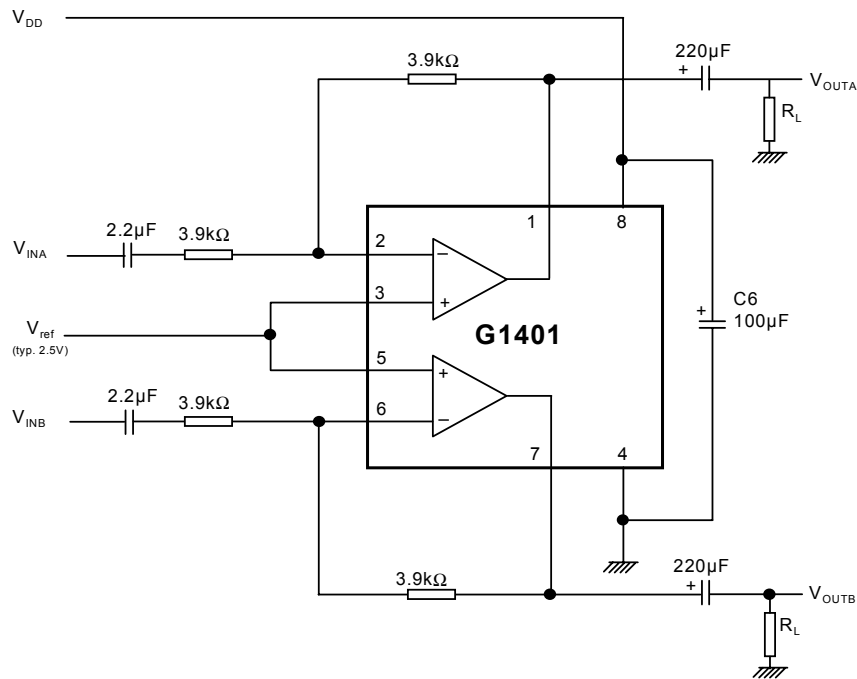

**Fig.1 Measurement circuit for inverting application**

## Electrical Characteristics

$V_{DD} = 5V$ ;  $V_{SS} = 0V$ ;  $T_{amb} = 25^{\circ}C$ ;  $f_i = 1kHz$ ;  $R_L = 32\Omega$ ; unless otherwise specified.

SYMBOL	PARAMETER	CONDITIONS	MIN.	TYP.	MAX.	UNIT
<b>Supplies</b>						
$V_{DD}$	Supply voltage		3.0	5.0	7.0	V
	Single		3.0	5.0	7.0	V
	Dual		1.5	2.5	3.5	V
$V_{SS}$	Negative supply voltage		-1.5	-2.5	-3.5	V
$I_{DD}$	Supply current	no load	-	3.0	5.5	mA
$P_{tot}$	Total power dissipation	no load	-	15	28	mW
<b>DC Characteristics</b>						
$V_{I(OS)}$	Input offset voltage		-15	-	15	mV
$V_{CM}$	Common mode voltage		0	-	4.0	V
CMRR	Common-Mode Rejection Ratio	$V_{CM} = 0V$ to $5V$	40	60		dB
$G_V$	Open-loop voltage gain	$R_L = 5k\Omega$	70	90	-	dB
$I_O$	Maximum output current	THD<0.1%	-	100	-	mA
$R_O$	Output resistance	open-loop $R_L = 20\Omega$	-	1.78	-	$\Omega$
$V_O$	Output voltage swing	$R_L = 32\Omega$ note 1	1.0	-	4.0	V
		$R_L = 5k\Omega$ note 1	0.1	-	4.9	V
PSRR	Power supply rejection ratio	$f_i = 1kHz$ ; $V_{ripple(peak)} = 1V$	50	62	-	dB
$\alpha_{CS}$	Channel separation		-	70	-	dB
<b>AC Characteristics</b>						
THD	Total harmonic distortion	note 2	-	< 0.1	-	%
		$R_L = 5k\Omega$ note 2				
$f_G$	Unity gain frequency	open-loop; $R_L = 5k\Omega$	2.5	3.7	5.0	MHz
$P_O$	Maximum output power	note 1; $R_L = 16\Omega$	-	135	-	mW
B	Power bandwidth	unity gain inverting	-	30	-	kHz

### Notes:

1. Values are proportional to  $V_{DD}$ ; THD < 0.1%
2.  $V_{DD} = 5.0V$ ;  $V_{O(P-P)} = 4.0V$  (at 0 dB)

**Output Swing Range Voltage Figure**

Test Condition :  $T_A = 25^\circ\text{C}$ ,  $A_V = -1$

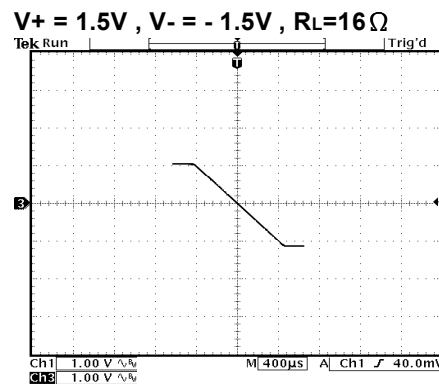
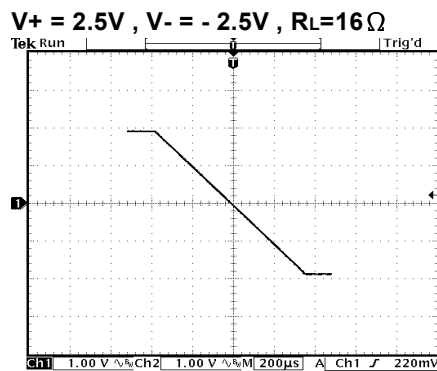
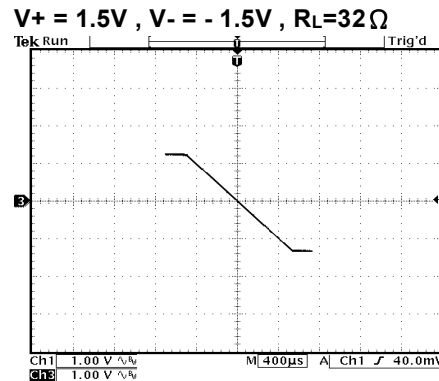
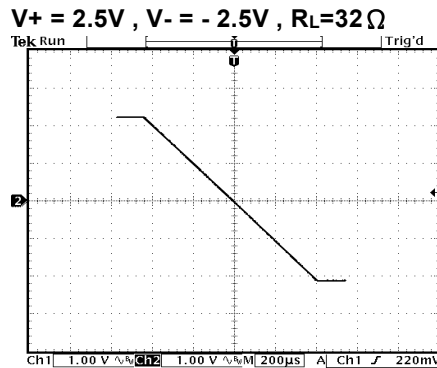
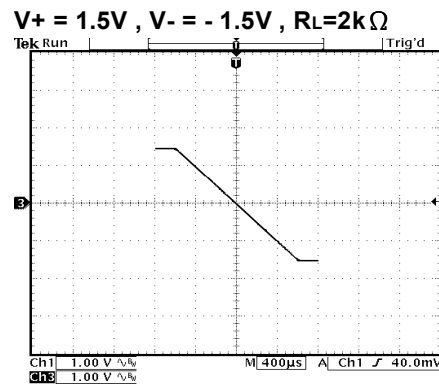
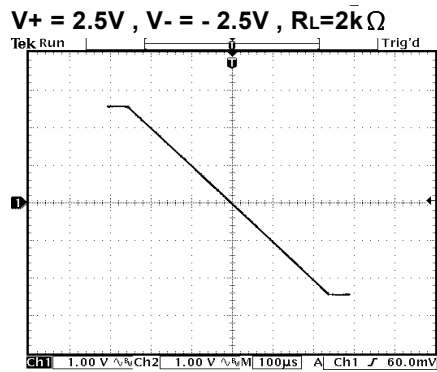
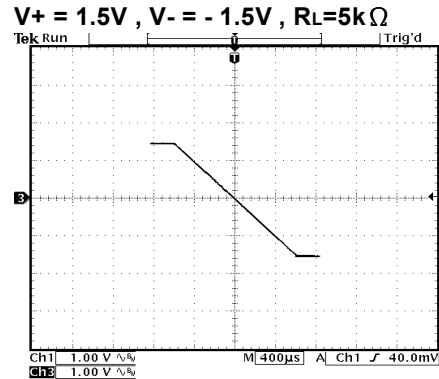
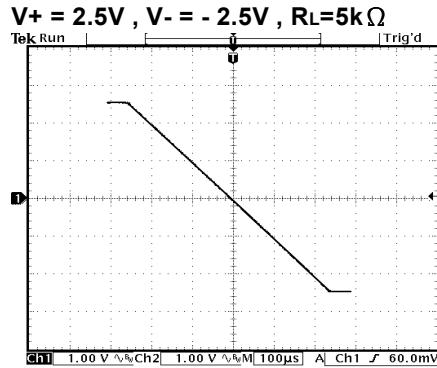

**Input Common Mode Voltage Range Figure**

Test Condition :  $T_A = 25^\circ\text{C}$ ,  $A_V = 1$

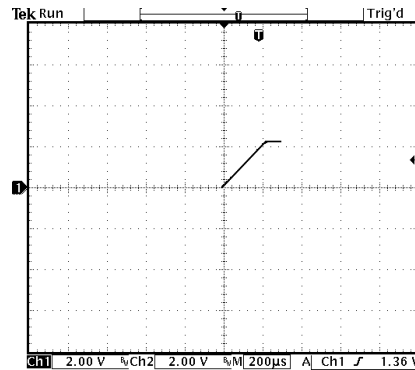
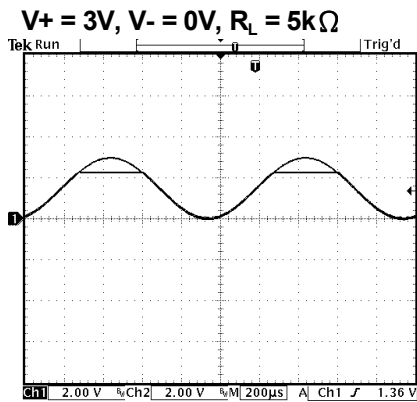
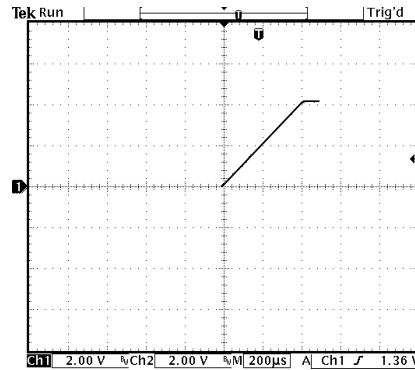
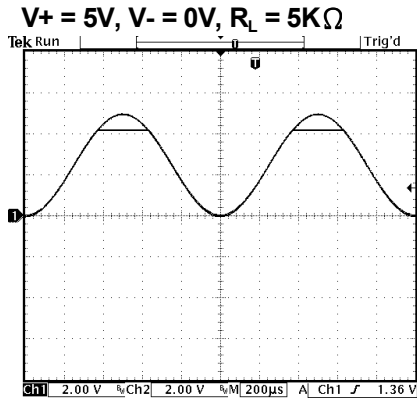

**Test Condition:  $V_s = \pm 2.5\text{V}$ ,  $T_A = 25^\circ\text{C}$**

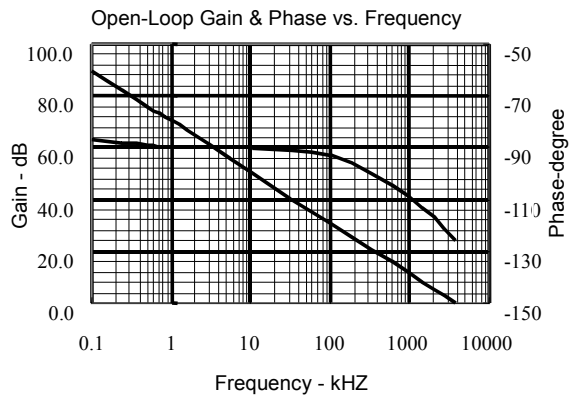

**Test Condition:  $V_s = \pm 2.5\text{V}$ ,  $T_A = 25^\circ\text{C}$**

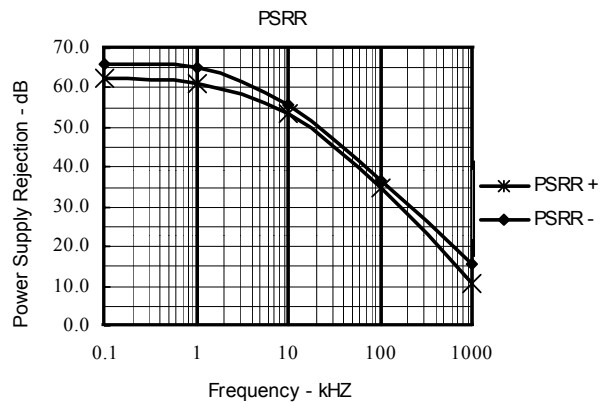

**Package Information**

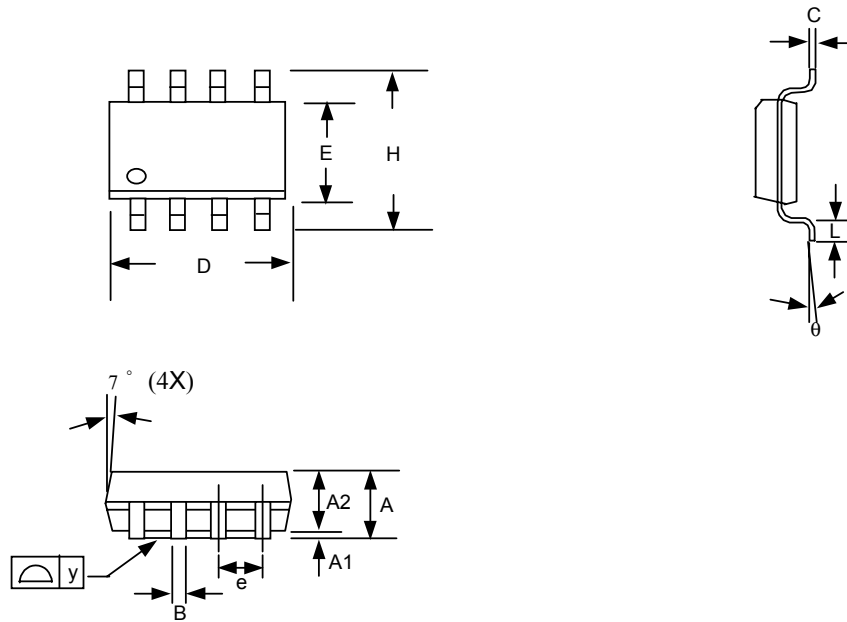

1. Package body sizes exclude mold flash and gate burrs
2. Dimension L is measured in gage plane
3. Tolerance 0.10mm unless otherwise specified
4. Controlling dimension is millimeter converted inch dimensions are not necessarily exact.

SYMBOL	DIMENSION IN MM			DIMENSION IN INCH		
	MIN.	NOM.	MAX.	MIN.	NOM.	MAX.
A	1.35	1.60	1.75	0.053	0.063	0.069
A1	0.10	-----	0.25	0.004	-----	0.010
A2	-----	1.45	-----	-----	0.057	-----
B	0.33	-----	0.51	0.013	-----	0.020
C	0.19	-----	0.25	0.007	-----	0.010
D	4.80	-----	5.00	0.189	-----	0.197
E	3.80	-----	4.00	0.150	-----	0.157
e	-----	1.27	-----	-----	0.050	-----
H	5.80	-----	6.20	0.228	-----	0.244
L	0.40	-----	1.27	0.016	-----	0.050
y	-----	-----	0.10	-----	-----	0.004
θ	0°	-----	8°	0°	-----	8°

**Taping Specification**

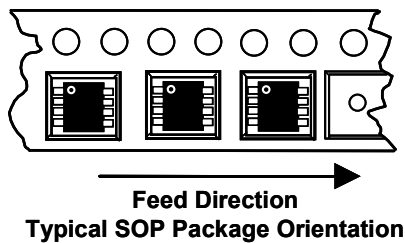

GMT Inc. does not assume any responsibility for use of any circuitry described, no circuit patent licenses are implied and GMT Inc. reserves the right at any time without notice to change said circuitry and specifications.