

EN29F002 / EN29F002N

2 Megabit (256K x 8-bit) Flash Memory

FEATURES

- 5.0V \pm 10% for both read/write operation
- Read Access Time
 - 45ns, 55ns, 70ns, and 90ns
- Fast Read Access Time
 - 70ns with $C_{load} = 100\text{pF}$
 - 45ns, 55ns with $C_{load} = 30\text{pF}$
- Sector Architecture:
One 16K byte Boot Sector, Two 8K byte Parameter Sectors, one 32K byte and three 64K byte main Sectors
- Boot Block Top/Bottom Programming Architecture
- High performance program/erase speed
 - Byte program time: 10 μ s typical
 - Sector erase time: 500ms typical
 - Chip erase time: 3.5s typical
- Low Standby Current
 - 1 μ A CMOS standby current-typical
 - 1mA TTL standby current
- Low Power Active Current
 - 30mA active read current
 - 30mA program / erase current
- JEDEC Standard program and erase commands
- JEDEC standard $\overline{\text{DATA}}$ polling and toggle bits feature
- Hardware $\overline{\text{RESET}}$ Pin (n/a for EN29F002N)
- Single Sector and Chip Erase
- Sector Protection / Temporary Sector Unprotect ($\overline{\text{RESET}} = V_{ID}$)
- Sector Unprotect Mode
- Embedded Erase and Program Algorithms
- Erase Suspend / Resume modes:
Read and program another sector during Erase Suspend Mode
- 0.4 μm double-metal double-poly triple-well CMOS Flash Technology
- Low Vcc write inhibit $\leq 3.2\text{V}$
- 100K endurance cycle
- Package Options
 - 32-pin PDIP
 - 32-pin PLCC
 - 32-pin TSOP (Type 1)
- Commercial and Industrial Temperature Ranges

GENERAL DESCRIPTION

The EN29F002 / EN29F002N is a 2-Megabit, electrically erasable, read/write non-volatile flash memory. Organized into 256K words with 8 bits per word, the 2M of memory is arranged in seven sectors (with top/bottom configuration), including one 16K Byte Boot Sector, two 8K Byte Parameter sectors, and four main sectors (one 32K Byte and three 64K Byte). Any byte can be programmed typically at 10 μ s. The EN29F002 / EN29F002N features 5.0V voltage read and write operation. The access times are as fast as 45ns to eliminate the need for WAIT states in high-performance microprocessor systems.

The EN29F002 / EN29F002N has separate Output Enable ($\overline{\text{OE}}$), Chip Enable ($\overline{\text{CE}}$), and Write Enable ($\overline{\text{WE}}$) controls which eliminate bus contention issues. This device is designed to allow either single sector or full chip erase operation, where each sector can be individually protected against program/erase operations or temporarily unprotected to erase or program. The device can sustain a minimum of 100K program/erase cycles on each sector.

TABLE 1. PIN DESCRIPTION

Pin Name	Function
A0-A17	Addresses
DQ0-DQ7	Data Input/Outputs
$\overline{\text{CE}}$	Chip Enable
$\overline{\text{OE}}$	Output Enable
$\overline{\text{WE}}$	Write Enable
$\overline{\text{RESET}}$ (n/a for EN29F002N)	Hardware Reset Sector Unprotect
Vcc	Supply Voltage (5V \pm 10%)
Vss	Ground

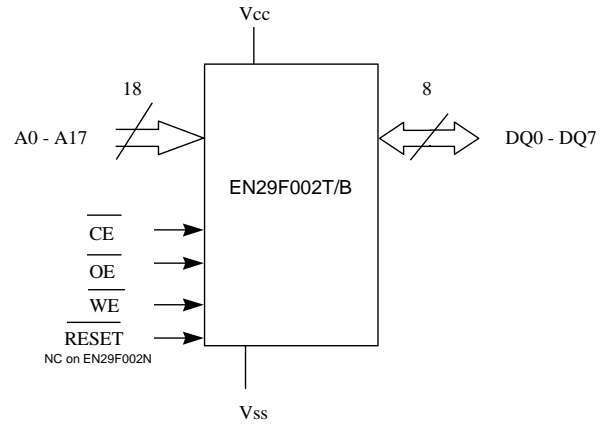
FIGURE 1. LOGIC DIAGRAM

TABLE 2. BLOCK ARCHITECTURE
TOP BOOT BLOCK

SECTOR	ADDRESSES	SIZE (Kbytes)
6	3C000h - 3FFFFh	16
5	3A000h - 3BFFFh	8
4	38000h - 39FFFh	8
3	30000h - 37FFFh	32
2	20000h - 2FFFFh	64
1	10000h - 1FFFFh	64
0	00000h - 0FFFFh	64

BOTTOM BOOT BLOCK

ADDRESSES	SIZE (Kbytes)
30000h - 3FFFFh	64
20000h - 2FFFFh	64
10000h - 1FFFFh	64
08000h - 0FFFFh	32
06000h - 07FFFh	8
04000h - 05FFFh	8
00000h - 03FFFh	16

BLOCK DIAGRAM

FIGURE 2. PDIP

FIGURE 3. TSOP

FIGURE 4. PLCC

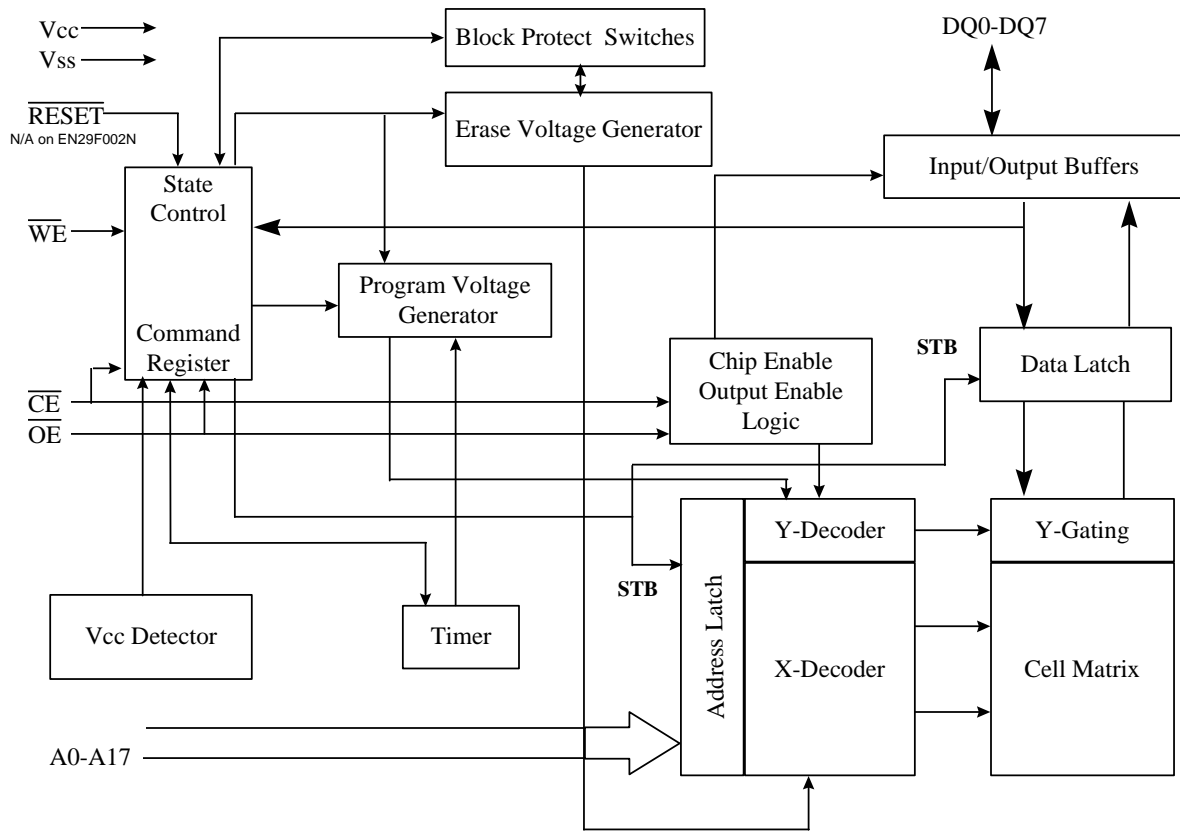

TABLE 3. OPERATING MODES

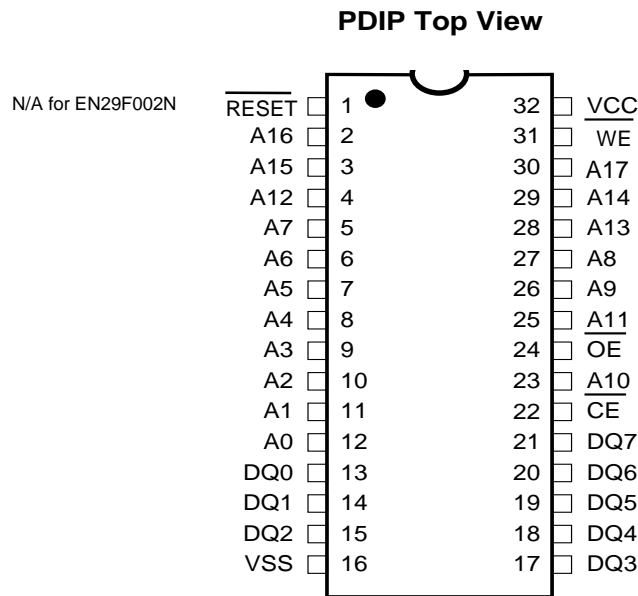
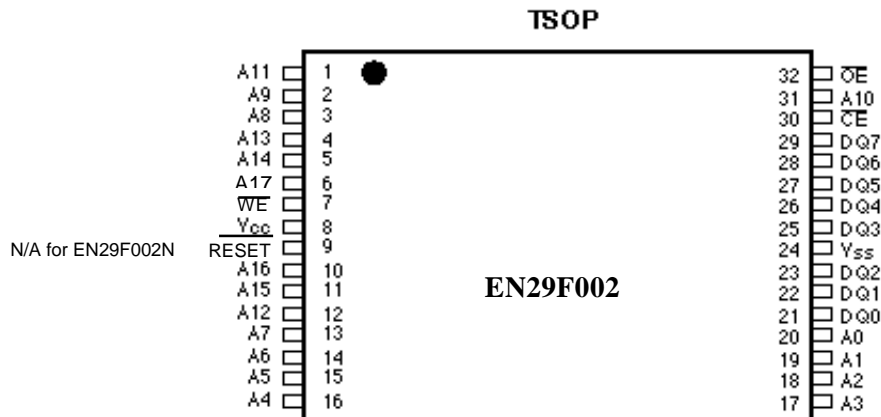
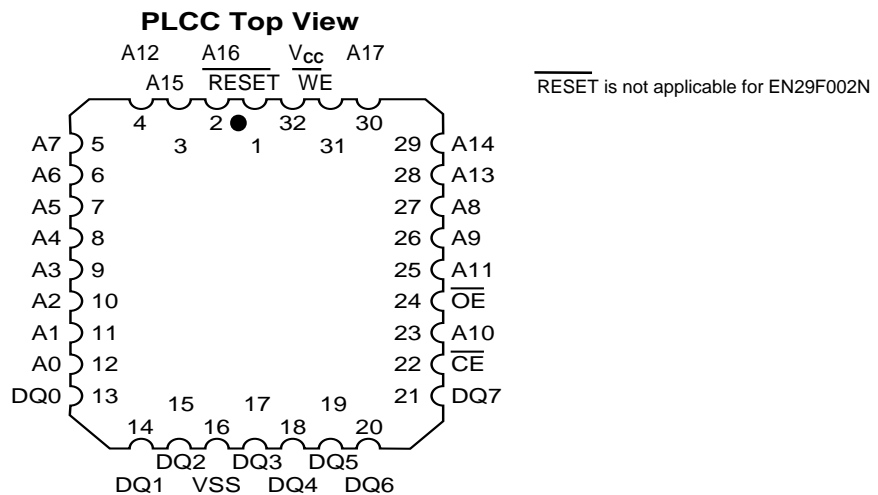
2M FLASH USER MODE TABLE

	\overline{CE}	\overline{WE}	\overline{OE}	RESET	A9	A8	A6	A1	A0	Ax/y	DQ(0-7)
USER MODE											
RESET (n/a for EN29F002N)	X	X	X	L	X	X	X	X	X	X	HI-Z
STANDBY	H	X	X	H	X	X	X	X	X	X	HI-Z
READ	L	H	L	H	A9	A8	A6	A1	A0	Ax/y	DQ(0-7)
OUTPUT DISABLE	L	H	H	H	A9	A8	A6	A1	A0	Ax/y	HI-Z
READ MANUFACTURER ID	L	H	L	H	VID	L/H	L	L	L	X	MANUFACTURER ID
READ DEVICE ID	L	H	L	H	VID	L/H	L	L	H	X	DEVICE ID(T/B)
VERIFY SECTOR PROTECT	L	H	L	H	VID	X	L	H	L	X	CODE
ENABLE SECTOR PROTECT	L	L	VID	H	VID	X	L	X	X	X	X
SECTOR UNPROTECT	L	L	VID	H	VID	X	H	H	L	X	X
WRITE	L	L	H	H	A9	A8	A6	A1	A0	Ax/y	DIN(0-7)
TEMPORARY SECTOR UNPROTECT	X	X	X	VID	X	X	X	X	X	X	X

NOTES:

- 1) L = V_{IL} , H = V_{IH} , $V_{ID} = 11.0V \pm 0.5V$
- 2) X = Don't care, either V_{IH} or V_{IL}

TABLE 4. DEVICE IDENTIFICATION

2M FLASH MANUFACTURER/DEVICE ID TABLE

	A8	A6	A1	A0	DQ(7-0) HEX
READ MANUFACTURER ID	L	L	L	L	MANUFACTURER ID 7F
READ MANUFACTURER ID	H	L	L	L	MANUFACTURER ID 1C
READ DEVICE ID (Top Architecture)	L	L	L	H	DEVICE ID 7F
READ DEVICE ID (Top Architecture)	H	L	L	H	DEVICE ID 92
READ DEVICE ID (Bottom Architecture)	L	L	L	H	DEVICE ID 7F
READ DEVICE ID (Bottom Architecture)	H	L	L	H	DEVICE ID 97

USER MODE DEFINITIONS

Reset Mode

EN29F002 features a Reset mode that resets the program and erase operation immediately to read mode. If reset ($\overline{\text{RESET}} = \text{L}$) is executed when program or erase operation were in progress, the program or erase which was terminated should be repeated since data will be corrupted. This pin is not available for EN29F002N.

Standby Mode

The EN29F002 / EN29F002N has a CMOS-compatible standby mode which reduces the current to $< 1\mu\text{A}$ (typical). It is placed in CMOS-compatible standby when $\overline{\text{CE}}$ and the $\overline{\text{RESET}}$ pins are at $V_{\text{CC}} \pm 0.5\text{ V}$ ($\overline{\text{CE}}$ pin only, for EN29F002N). The device also has a TTL-compatible standby mode which reduces the maximum V_{CC} current to $< 1\text{mA}$. It is placed in TTL-compatible standby when $\overline{\text{CE}}$ and $\overline{\text{RESET}}$ pins are at V_{IH} . Another method of entering standby mode uses only the $\overline{\text{RESET}}$ pin (n/a for EN29F002N). When $\overline{\text{RESET}}$ pin is at $V_{\text{SS}} \pm 0.3\text{V}$, the device enters CMOS-compatible standby with current typically reduced to $< 1\mu\text{A}$. When $\overline{\text{RESET}}$ pin is at V_{IL} , the device enters TTL-compatible standby with current reduced to $< 1\text{mA}$. When in standby modes, the outputs are in a high-impedance state independent of the $\overline{\text{OE}}$ input.

Read Mode

The EN29F002 / EN29F002N has two control functions which must be satisfied in order to obtain data at the outputs. Chip Enable ($\overline{\text{CE}}$) is the power control and should be used for device selection. Output Enable ($\overline{\text{OE}}$) is the output control and should be used to gate data to the output pins, provided the device is selected. Read is selected when both $\overline{\text{CE}}$ and $\overline{\text{OE}}$ pins are held at V_{IL} with the $\overline{\text{WE}}$ pin held at V_{IH} . Address access time (t_{ACC}) is equal to the delay from stable addresses to valid output data. Assuming that addresses are stable, chip enable access time (t_{CE}) is equal to the delay from stable $\overline{\text{CE}}$ to valid data at output pins. Data is available at the outputs after output enable access time (t_{OE}) from the falling edge of $\overline{\text{OE}}$, assuming the $\overline{\text{CE}}$ has been LOW and addresses have been stable for at least $t_{\text{ACC}} - t_{\text{OE}}$.

Output Disable Mode

When the $\overline{\text{CE}}$ or $\overline{\text{OE}}$ pin is at a logic high level (V_{IH}), the output from the EN29F002 / EN29F002N is disabled. The output pins are placed in a high impedance state.

Auto Select Identification Mode

The manufacturer and device type can be identified by hardware or software operations. This mode allows applications or programming equipment automatically matching the device with its corresponding interface characteristics.

To activate the Auto Select Identification mode, the programming equipment must force $12.0\text{ V} \pm 0.5\text{V}$ on address line A9 of the EN29F002T/B. Two identifier bytes can then be sequenced from the device outputs by toggling address lines A0 and A8 from V_{IL} to V_{IH} .

The manufacturer and device identification may also be read via the command register. By following the command sequence referenced in the Command Definition Table (Table 5). This method is desirable for in-system identification (using only $+5.0\text{V}$).

When $A0 = A1 = A6 = V_{\text{IL}}$ and by toggling A8 from V_{IL} to V_{IH} , the Manufacturer ID can be read as Eon = 7F, 1C (hex) to identify EON. When $A0 = V_{\text{IH}}$, $A1 = A6 = V_{\text{IL}}$, and by toggling A8 from V_{IL} to V_{IH} , the



Device Code can be read as 7F, 92 (hex) for EN29F002T or as 7F, 97 (hex) for EN29F002B (See Table 4). All identifiers for manufacturer and device codes possess odd parity with the DQ7 defined as the parity bit.

Write Mode

Write is used for device programming and erase through the command register. This mode is selected with $\overline{CE} = \overline{WE} = L$ and $\overline{OE} = H$. The contents of the command register are the inputs to the internal state machine. The command register is a set of latches used to store the commands along with the addresses and data information needed to execute that command. Address latching occurs on the falling edge of \overline{WE} or \overline{CE} (whichever occurs later) and data latching occurs on the rising edge of \overline{WE} or \overline{CE} (whichever occurs first).

Temporary Sector Unprotect Mode

EN29F002 allows protected sectors to be temporarily unprotected for making changes to data stored in a protected sector in system (n/a for EN29F002N). To activate the temporary sector unprotect, the \overline{RESET} pin must be set to a high voltage of V_{ID} (11V). In this mode, protected sectors can be programmed or erased by selecting the sector addresses. Once the high voltage, V_{ID} , is removed from \overline{RESET} pin, all previously protected sectors will revert to their protected state.

\overline{RESET} Hardware Reset Mode (not available on EN29F002N)

Resetting the EN29F002 device is performed when the \overline{RESET} pin is set to V_{IL} and kept low for at least 500ns. The internal state machine will be reset to the read mode. Any program/erase operation in progress during hardware reset will be terminated and data may be corrupted.

If the \overline{RESET} pin is tied to the system reset command, the device will be automatically reset to the read mode and enable the system's microprocessor to read the boot-up firmware from the FLASH memory.

COMMAND DEFINITIONS

The operations of the EN29F002 are selected by one or more commands written into the command register to perform Read/Reset Memory, Read ID, Read Sector Protection, Program, Sector Erase, Chip Erase, Erase Suspend and Erase Resume. Commands are made up of data sequences written at specific addresses via the command register. The sequences for the specified operation are defined in the Command Table (Table 5). Incorrect addresses, incorrect data values or improper sequences will reset the device to the read mode.

Table 5. EN29F002 Command Definitions

Command Sequence Read/Reset	Write Cycles Req'd	1 st Write Cycle		2 nd Write Cycle		3 rd Write Cycle		4 th Write Cycle		5 th Write Cycle		6 th Write Cycle	
		Addr	Data	Addr	Data	Addr	Data	Addr	Data	Addr	Data	Addr	Data
Read/Reset	1	XXXh	F0h	RA	RD								
Read/Reset	4	555h	AAh	AAAh	55h	555h	F0h	RA	RD				
AutoSelect Manufacturer ID	4	555h	AAh	AAAh	55h	555h	90h	000h/100h	7Fh/1Ch				
AutoSelect Device ID (Top Boot)	4	555h	AAh	AAAh	55h	555h	90h	001h/101h	7Fh/92h				
AutoSelect Device ID (Bottom Boot)	4	555h	AAh	AAAh	55h	555h	90h	001h/101h	7Fh/97h				
AutoSelect Sector Protect Verify	4	555h	AAh	AAAh	55h	555h	90h	SA & 02h	00h/01h				
Byte Program	4	555h	AAh	AAAh	55h	555h	A0h	PA	PD				
Chip Erase	6	555h	AAh	AAAh	55h	555h	80h	555h	AAh	AAAh	55h	555h	10h
Sector Erase	6	555h	AAh	AAAh	55h	555h	80h	555h	AAh	AAAh	55h	SA	30h
Sector Erase Suspend	1	xxxh	B0h										
Sector Erase Resume	1	xxxh	30h										

Notes:

RA = Read Address: address of the memory location to be read. This one is a read cycle.
 RD = Read Data: data read from location RA during Read operation. This one is a read cycle.
 PA = Program Address: address of the memory location to be programmed
 PD = Program Data: data to be programmed at location PA
 SA = Sector Address: address of the sector to be erased. Address bits A17-A13 uniquely select any sector.

Byte Programming Command

Programming the EN29F002 is performed on a byte-by-byte basis using a four bus-cycle operation (two unlock write cycles followed by the Program Setup command and Program Data Write cycle). When the program command is executed, no additional CPU controls or timings are necessary. The program operation is terminated automatically by an internal timer. Address is latched on the falling edge of \overline{CE} or \overline{WE} , whichever is last; data is latched on the rising edge of \overline{CE} or \overline{WE} , whichever is first. The program operation is completed when EN29F002 returns the equivalent data to the programmed location.

Programming status may be checked by sampling data on DQ7 (\overline{DATA} polling) or on DQ6 (toggle bit). Changing data from 0 to 1 requires an erase operation. When programming time limit is exceeded, DQ5 will produce a logical "1" and a Reset command can return the device to Read mode.

EN29F002 ignores commands written during Byte Programming. If a hardware \overline{RESET} occurs during Byte Programming, data at the programmed location may get corrupted. Programming is allowed in any sequence and across any sector boundary.

Chip Erase Command

An auto Chip Erase algorithm is employed when the Chip Erase command sequence is performed. Although the Chip Erase command requires six bus cycles: two unlock write cycles, a setup command, two additional unlock write cycles and the chip erase command, the user does not need to do anything else after that, except check to see if the operation has completed. The Auto Chip Erase algorithm automatically programs and verifies the entire memory array for an all "0" pattern prior to



the erase. Then the EN29F002 will automatically time the erase pulse width, verify the erase, return the sequence count, provide a erase status through $\overline{\text{DATA}}$ POLLING (data on DQ7 is "0" during the operation and "1" when completed, provided the status is not read from a protected sector), and returns to the READ mode after completion of Chip Erase.

Sector Erase Command

Sector Erase requires six bus cycles: two unlock write cycles, a setup command, two additional unlock write cycles, and the Sector Erase command. Any sector may be erased by latching any address within the desired sector on the falling edge of $\overline{\text{WE}}$ while the Erase Command (30H) is latched on the rising edge of $\overline{\text{WE}}$. This device does not support multiple sector erase commands. Sector Erase operation will commence immediately after the first 30h command is written. The first sector erase operation must finish before another sector erase command can be given.

The EN29F002 device automatically programs and verifies all memory locations in the selected sector for an all "0" pattern prior to the erase. Unselected sectors are unaffected by the Sector Erase command. The EN29F002 requires no timing signals during sector erase. Erase is completed when data on DQ7 becomes "1", and the device returns to the READ mode after completion of Sector Erase.

Erase Suspend / Resume Command

Erase suspend allows interruption of sector erase operations to perform data reads from sector not being erased. Erase suspend applies only to Sector Erase operations.

EN29F002 ignores any commands during erase suspend other than the assertion of the $\overline{\text{RESET}}$ pin (n/a for EN29F002N) or Erase Resume commands. Writing erase resume continues erase operations. Addresses are DON'T CARE when writing Erase Suspend or Erase Resume commands.

EN29F002 takes 0.1 - 15 μs to suspend erase operations after receiving Erase Suspend command. Check completion of erase suspend by polling DQ7 and/or DQ6. EN29F002 ignores redundant writes of erase suspend command.

EN29F002 defaults to erase-suspend-read mode while an erase operation has been suspended. While in erase-suspend-read mode, EN29F002 allows reading data in any sector not undergoing sector erase, which is treated as standard read mode.

Write the Resume command 30h to continue operation of Sector erase. En29F002 ignores redundant writes of the Resume command. En29F002 permits multiple suspend/resume operations during sector erase.

Sector Protect and Unprotect

The hardware sector protection feature disables both program and erase operations in any sector. The hardware sector unprotection feature re-enables both program and erase operation in previously protected sectors.

Sector protection/unprotection must be implemented using programming equipment. The procedure requires a high voltage (V_{ID}) on address pin A9 and the control pins. Contact Eon Silicon Devices, Inc. for an additional supplement on this feature.

WRITE OPERATION STATUS

DQ7

$\overline{\text{DATA}}$ Polling

The EN29F002 provides $\overline{\text{DATA}}$ Polling on DQ7 to indicate to the host system the status of the embedded operations. The $\overline{\text{DATA}}$ Polling feature is active during the Byte Programming, Sector Erase, Chip Erase, Erase Suspend. (See Table 6)

When the Byte Programming is in progress, an attempt to read the device will produce the complement of the data last written to DQ7. Upon the completion of the Byte Programming, an attempt to read the device will produce the true data last written to DQ7. For the Byte Programming, $\overline{\text{DATA}}$ polling is valid after the rising edge of the fourth $\overline{\text{WE}}$ or $\overline{\text{CE}}$ pulse in the four-cycle sequence.

When the embedded Erase is in progress, an attempt to read the device will produce a “0” at the DQ7 output. Upon the completion of the embedded Erase, the device will produce the “1” at the DQ7 output during the read. For Chip Erase, the $\overline{\text{DATA}}$ polling is valid after the rising edge of the sixth $\overline{\text{WE}}$ or $\overline{\text{CE}}$ pulse in the six-cycle sequence. For Sector Erase, $\overline{\text{DATA}}$ polling is valid after the last rising edge of the sector erase $\overline{\text{WE}}$ or $\overline{\text{CE}}$ pulse.

$\overline{\text{DATA}}$ Polling must be performed at any address within a sector that is being programmed or erased and not a protected sector. Otherwise, $\overline{\text{DATA}}$ polling may give an inaccurate result if the address used is in a protected sector.

Just prior to the completion of the embedded operations, DQ7 may change asynchronously when the output enable ($\overline{\text{OE}}$) is low. This means that the device is driving status information on DQ7 at one instant of time and valid data at the next instant of time. Depending on when the system samples the DQ7 output, it may read the status of valid data. Even if the device has completed the embedded operations and DQ7 has a valid data, the data output on DQ0-DQ6 may be still invalid. The valid data on DQ0-DQ7 will be read on the subsequent read attempts.

The flowchart for $\overline{\text{DATA}}$ Polling (DQ7) is shown on Flowchart 5. The $\overline{\text{DATA}}$ Polling (DQ7) timing diagram is shown in Figure 8.

DQ6

Toggle Bit I

The EN29F002 provides a “Toggle Bit” on DQ6 to indicate to the host system the status of the embedded programming and erase operations. (See Table 6)

During an embedded Program or Erase operation, successive attempts to read data from the device at any address (by toggling $\overline{\text{OE}}$ or $\overline{\text{CE}}$) will result in DQ6 toggling between “zero” and “one”. Once the embedded Program or Erase operation is complete, DQ6 will stop toggling and valid data will be read on the next successive attempts. During Byte Programming, the Toggle Bit is valid after the rising edge of the fourth $\overline{\text{WE}}$ pulse in the four-cycle sequence. For Chip Erase, the Toggle Bit is valid after the rising edge of the sixth-cycle sequence. For Sector Erase, the Toggle Bit is valid after the last rising edge of the Sector Erase Command (30h) $\overline{\text{WE}}$ pulse.

In Byte Programming, if the sector being written to is protected, DQ6 will toggle for about 2 μ s, then stop toggling without the data in the sector having changed. In Sector Erase or Chip Erase, if all selected sectors are protected, DQ6 will toggle for about 100 μ s. The chip will then return to the read mode without changing data in all protected sectors.

Toggling either $\overline{\text{CE}}$ or $\overline{\text{OE}}$ will cause DQ6 to toggle.

The flowchart for the Toggle Bit (DQ6) is shown in Flowchart 6. The Toggle Bit timing diagram is shown in Figure 9.

DQ5

Exceeded Timing Limits

DQ5 will indicate if the program or erase time has exceeded the specified limits (internal pulse count). Under these conditions DQ5 will produce a "1". (The Toggle Bit (DQ6) should also be checked at this time to make sure that the DQ5 is not a "1" due to the device having returned to read mode.) This is a failure condition which indicates that the program or erase cycle was not successfully completed. $\overline{\text{DATA}}$ Polling (DQ7), Toggle Bit (DQ6) and Erase Toggle Bit (DQ2) still function under this condition. Setting the $\overline{\text{CE}}$ to V_{IH} will partially power down the device under those conditions. The $\overline{\text{OE}}$ and $\overline{\text{WE}}$ pins will control the output disable functions as described in Table 3.

The DQ5 failure condition will also appear if the user tries to program a "1" to a location that was previously programmed to a "0". In this case, the device goes into Hang or Error mode out and never completes the Embedded Program Algorithm. Hence, the system never reads valid data on DQ7 and DQ6 never stops toggling. Once the device exceeds the timing limits, DQ5 will indicate a "1". Please note that this is not a device failure condition since the device was used incorrectly. If timing limits are exceeded, reset the device. (See Table 6)

DQ3

Sector Erase Command Timeout

This device does not support multiple sector erase commands. DQ3 will go high immediately after the first 30h command (the sixth write cycle). Any extra 30h commands will be ignored (or taken as a resume command if erase suspended).

DQ2

Erase Toggle Bit II

In the sector erase operation, DQ2 will toggle with $\overline{\text{OE}}$ or $\overline{\text{CE}}$ when a read is attempted within the sector that is being erased. DQ2 will not toggle if the read address is not within the sector that is selected to be erased. In the chip erase operation, however, DQ2 will toggle with $\overline{\text{OE}}$ or $\overline{\text{CE}}$ regardless of the address given by the user. This is because all sectors are to be erased. (See Table 6)

Table 6. Status Register Bits

DQ	Name	Logic Level	Definition
7	DATA POLLING	'1'	Erase Complete or erase sector in Erase suspend
		'0'	Erase On-Going
		DQ7	Program Complete or data of non-erase sector during Erase Suspend
		DQ7	Program On-Going
6	TOGGLE BIT	'-1-0-1-0-1-0-1-'	Erase or Program On-going
		DQ6	Read during Erase Suspend
		'-1-1-1-1-1-1-1-'	Erase Complete
5	ERROR BIT	'1'	Program or Erase Error
		'0'	Program or Erase On-going
3	ERASE TIME BIT	'1'	Erase operation start
		'0'	Erase timeout period on-going
2	TOGGLE BIT	'-1-0-1-0-1-0-1-'	Chip Erase, Erase or Erase suspend on currently addressed sector. (When DQ5=1, Erase Error due to currently addressed sector. Program during Erase Suspend on-going at current address)
		DQ2	Erase Suspend read on non Erase Suspend Sector

Notes:

DQ7 DATA Polling: indicates the P/E C status check during Program or Erase, and on completion before checking bits DQ5 for Program or Erase Success.

DQ6 Toggle Bit: remains at constant level when P/E operations are complete or erase suspend is acknowledged. Successive reads output complementary data on DQ6 while programming or Erase operation are on-going.

DQ5 Error Bit: set to "1" if failure in programming or erase

DQ3 Sector Erase Command Timeout Bit: Operation has started. Only possible command is Erase suspend (ES).

DQ2 Toggle Bit: indicates the Erase status and allows identification of the erased sector.

DATA PROTECTION

Power-up Write Inhibit

During power-up, the device automatically resets to READ mode and locks out write cycles. Even with $\overline{CE} = V_{IL}$, $\overline{WE} = V_{IL}$ and $\overline{OE} = V_{IH}$, the device will not accept commands on the rising edge of \overline{WE} .

Low V_{CC} Write Inhibit

During V_{CC} power-up or power-down, the EN29F002 locks out write cycles to protect against any unintentional writes. If $V_{CC} < V_{LKO}$, the command register is disabled and all internal program or erase circuits are disabled. Under this condition, the device will reset to the READ mode. Subsequent writes will be ignored until $V_{CC} > V_{LKO}$.

Write “Noise” Pulse Protection

Noise pulses less than 5ns on \overline{OE} , \overline{CE} or \overline{WE} will neither initiate a write cycle nor change the command register.

Logical Inhibit

If $\overline{CE} = V_{IH}$ or $\overline{WE} = V_{IH}$, writing is inhibited. To initiate a write cycle, \overline{CE} and \overline{WE} must be a logical “zero”. If \overline{CE} , \overline{WE} , and \overline{OE} are all logical zero (not recommended usage), it will be considered a write.

Sector Protection/Unprotection

When the device is shipped, all sectors are unprotected. Each sector can be separately protected against data changes. Using hardware protection circuitry enabled at user’s site with external programming equipment, both program and erase operations may be disabled for any specified sector or combination of sectors.

Verification of write protection for a specific sector can be achieved with an Auto Select ID read command at location 02h where the address bits A17 - A13 select the defined sector (see Table 5). A logical “1” at DQ0 means a protected sector and a logical “0” means an unprotected sector.

The Sector Unprotect disables sector protection in all sectors in one operation to implement code changes. All sectors must be placed in protection mode using the protection algorithm mentioned above before unprotection can be executed.

Additional details on this feature are provided in a supplement, which can be obtained by contacting a representative of Eon Silicon Devices, Inc.

EMBEDDED ALGORITHMS

Flowchart 1. Embedded Program

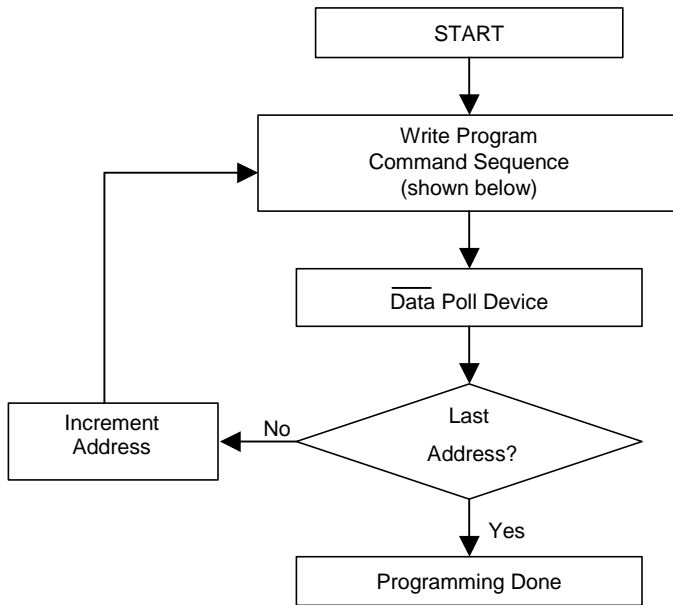

Flowchart 2. Embedded Program Command Sequence

See the Command Definitions section for more information.

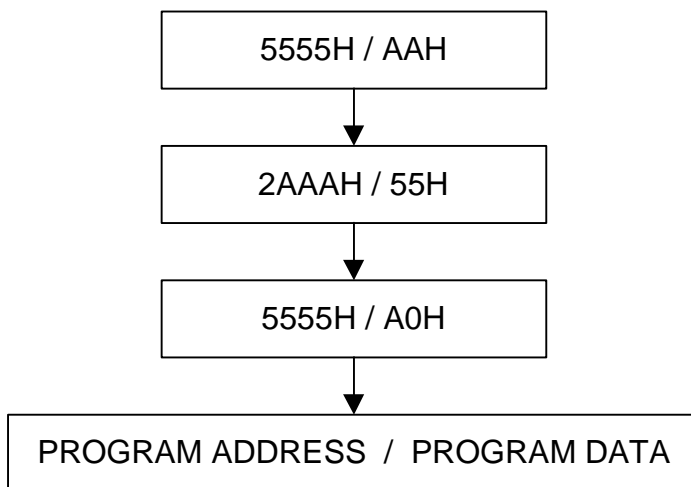

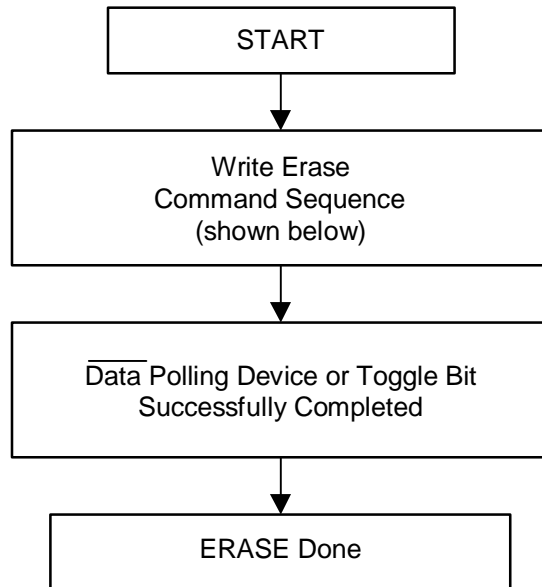
Flowchart 3. Embedded Erase

Flowchart 4. Embedded Erase Command Sequence

See the Command Definitions section for more information.

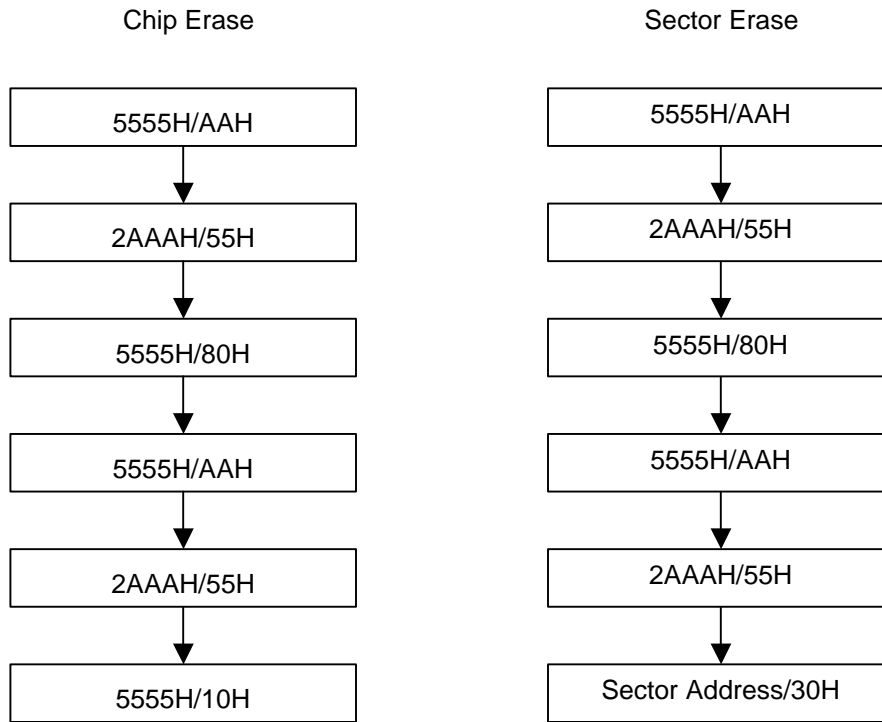

Flowchart 5. DATA Polling Algorithm

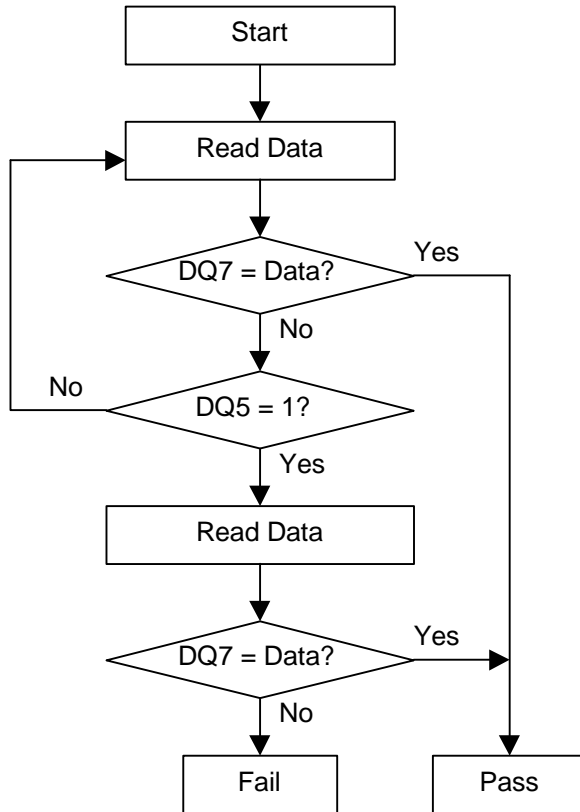

Flowchart 6. Toggle Bit Algorithm

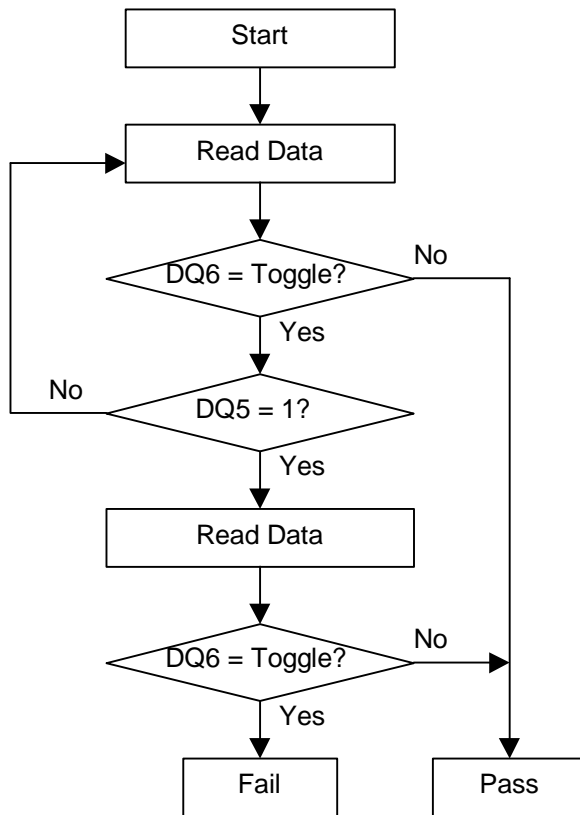

Flowchart 7. Temporary Sector Unprotect Algorithm
 (Not available for EN29F002N)

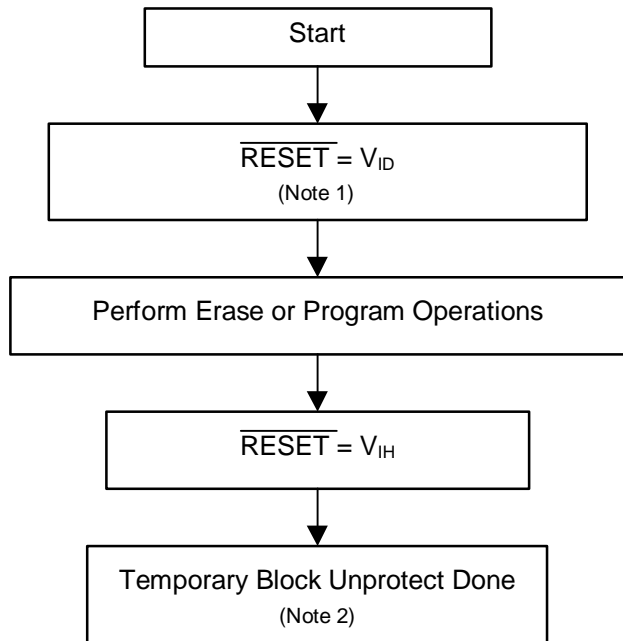

Notes:

1. All protected sectors unprotected.
2. All previous protected sectors are protected once again.

ABSOLUTE MAXIMUM RATINGS

Storage Temperature	
Plastic Packages	-65°C to +125°C
Ambient Temperature	
with Power Applied.	-55°C to +125°C
Voltage with Respect to Ground	
V _{CC} (Note 1)	-0.5 V to 7.0 V
A9, OE# (Note 2)	-0.5 V to 11.5 V
All other pins (Note 1)	-0.5 V to V _{CC} +0.5V
Output Short Circuit Current (Note 3)	200 mA

Notes:

1. Minimum DC voltage on input or I/O pins is -0.5 V. During voltage transitions, inputs may undershoot V_{SS} to -1.0V for periods of up to 50 ns and to -2.0 V for periods of up to 20 ns. See Left Figure below. Maximum DC voltage on input and I/O pins is V_{CC} + 0.5 V. During voltage transitions, input and I/O pins may overshoot to V_{CC} + 2.0 V for periods up to 20 ns. See Right Figure below.
2. Minimum DC input voltage on A9 pin is -0.5 V. During voltage transitions, A9 and OE# may undershoot V_{SS} to -1.0V for periods of up to 50 ns and to -2.0 V for periods of up to 20 ns. See Left Figure. Maximum DC input voltage on A9 and OE# is 11.5 V which may overshoot to 12.5 V for periods up to 20 ns.
3. No more than one output shorted to ground at a time. Duration of the short circuit should not be greater than one second. Stresses above those listed under "Absolute Maximum Ratings" may cause permanent damage to the device. This is a stress rating only; functional operation of the device at these or any other conditions above those indicated in the operational sections of this specification is not implied. Exposure of the device to absolute maximum rating conditions for extended periods may affect device reliability.

OPERATING RANGES

Commercial (C) Devices

Ambient Temperature (T_A) 0°C to +70°C

Industrial (I) Devices

Ambient Temperature (T_A) -40°C to +85°C

V_{CC} Supply Voltages

V_{CC} for ± 5% devices +4.75 V to +5.25 V

V_{CC} for ± 10% devices +4.50 V to +5.50 V

Operating ranges define those limits between which the functionality of the device is guaranteed.

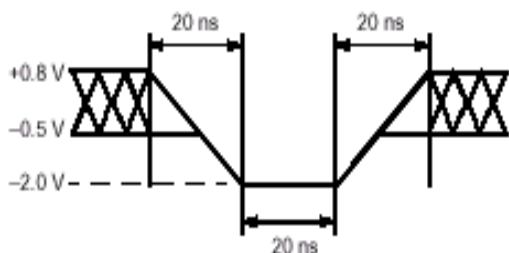

Maximum Negative Overshoot
Waveform

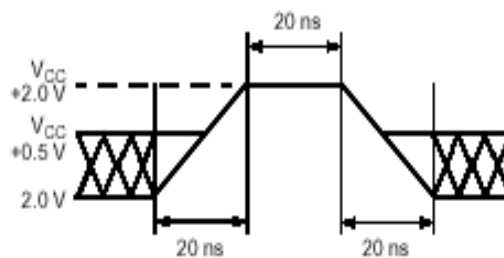

Maximum Positive Overshoot
Waveform

Table 7. DC Characteristics
 $(T_a = 0^\circ\text{C to } 70^\circ\text{C or } -40^\circ\text{C to } 85^\circ\text{C}; V_{CC} = 5.0\text{V} \pm 10\%)$

Symbol	Parameter	Test Conditions	Min	Max	Unit
I_{LI}	Input Leakage Current	$0\text{V} \leq V_{IN} \leq V_{CC}$		± 5	μA
I_{LO}	Output Leakage Current	$0\text{V} \leq V_{OUT} \leq V_{CC}$		± 5	μA
I_{CC1}	Supply Current (read) TTL Byte	$CE\# = V_{IL}; OE\# = V_{IH};$ $f = 6\text{MHz}$		30	mA
I_{CC2}	Supply Current (Standby) TTL	$CE\# = V_{IH}$		1.0	mA
I_{CC3}	Supply Current (Standby) CMOS ⁽¹⁾	$RESET\# = CE\# = V_{CC} \pm 0.2\text{V}$		5.0	μA
I_{CC4} ⁽²⁾	Supply Current (Program or Erase)	Byte program, Sector or Chip Erase in progress		30	mA
V_{IL}	Input Low Voltage		-0.5	0.8	V
V_{IH}	Input High Voltage		2	$V_{CC} \pm 0.5$	V
V_{OL}	Output Low Voltage	$I_{OL} = 2\text{ mA}$		0.45	V
V_{OH}	Output High Voltage TTL	$I_{OH} = -2.5\text{ mA}$	2.4		V
	Output High Voltage CMOS	$I_{OH} = -100\ \mu\text{A}$	$V_{CC} - 0.4\text{V}$		V
V_{ID}	A9 Voltage (Electronic Signature) and RESET# Voltage (Temporary Sector Unprotect)		10.5	11.5	V
I_{LIT}	A9 and RESET# Current (Electronic Signature)	$A9, RESET\# = V_{ID}$		100	μA
V_{LKO}	Supply voltage (Erase and Program lock-out)		3.2	4.2	V

Notes:

(1) RESET# pin input buffer is always enabled so that it draws power if not at full CMOS supply voltages

Table 8. AC CHARACTERISTICS
Read-only Operations Characteristics

Parameter Symbols		Description	Test Setup	Speed Options				Unit
JEDEC	Standard			-45	-55	-70	-90	
t_{AVAV}	t_{RC}	Read Cycle Time	Min	45	55	70	90	ns
t_{AVQV}	t_{ACC}	Address to Output Delay	$\overline{CE} = V_{IL}$ $\overline{OE} = V_{IL}$ Max	45	55	70	90	ns
t_{ELQV}	t_{CE}	Chip Enable To Output Delay	$\overline{OE} = V_{IL}$ Max	45	55	70	90	ns
t_{GLQV}	t_{OE}	Output Enable to Output Delay	Max	25	30	30	35	ns
t_{EHQZ}	t_{DF}	Chip Enable to Output High Z	Max	10	15	20	20	ns
t_{GHQZ}	t_{DF}	Output Enable to Output High Z	Max	10	15	20	20	ns
t_{AXQX}	t_{OH}	Output Hold Time from Addresses, \overline{CE} or \overline{OE} , whichever occurs first	Min	0	0	0	0	ns
	t_{Ready}	\overline{RESET} Pin Low to Read Mode (n/a for EN29F002N)	Max	20	20	20	20	μ s

Notes:

For -45,-55

$V_{CC} = 5.0V \pm 5\%$
 Output Load : 1 TTL gate and 30pF
 Input Rise and Fall Times: 5ns
 Input Rise Levels: 0.0 V to 3.0 V
 Timing Measurement Reference Level, Input and Output: 1.5 V

For all others:

$V_{CC} = 5.0V \pm 10\%$
 Output Load: 1 TTL gate and 100 pF
 Input Rise and Fall Times: 20 ns
 Input Pulse Levels: 0.45 V to 2.4 V
 Timing Measurement Reference Level, Input and Output: 0.8 V and 2.0 V

**Table 9. AC CHARACTERISTICS
Write (Erase/Program) Operations**

Parameter Symbols		Description		Speed Options				Unit
JEDEC	Standard			-45	-55	-70	-90	
t_{AVAV}	t_{WC}	Write Cycle Time	Min	45	55	70	90	ns
t_{AVWL}	t_{AS}	Address Setup Time	Min	0	0	0	0	ns
t_{WLAX}	t_{AH}	Address Hold Time	Min	35	45	45	45	ns
t_{DVWH}	t_{DS}	Data Setup Time	Min	20	25	30	45	ns
t_{WHDX}	t_{DH}	Data Hold Time	Min	0	0	0	0	ns
	t_{OES}	Output Enable Setup Time	Min	0	0	0	0	ns
	t_{OEH}	Output Enable Hold Time	Min	0	0	0	0	ns
		Read Toggle and DATA Polling	Min	10	10	10	10	ns
t_{GHWL}	t_{GHWL}	Read Recovery Time before Write (\overline{OE} High to \overline{WE} Low)	Min	0	0	0	0	ns
t_{ELWL}	t_{CS}	\overline{CE} Setup Time	Min	0	0	0	0	ns
t_{WHEH}	t_{CH}	\overline{CE} Hold Time	Min	0	0	0	0	ns
t_{WLWH}	t_{WP}	Write Pulse Width	Min	25	30	35	45	ns
t_{WHDL}	t_{WPH}	Write Pulse Width High	Min	20	20	20	20	ns
t_{WHWH1}	t_{WHWH1}	Programming Operation	Typ	7	7	7	7	μ s
			Max	200	200	200	200	μ s
t_{WHWH2}	t_{WHWH2}	Sector Erase Operation	Typ	0.3	0.3	0.3	0.3	s
			Max	5	5	5	5	s
t_{WHWH3}	t_{WHWH3}	Chip Erase Operation	Typ	3	3	3	3	s
			Max	35	35	35	35	s
	t_{VCS}	Vcc Setup Time	Min	50	50	50	50	μ s
	t_{VIDR}	Rise Time to V_{ID}	Min	500	500	500	500	ns
	t_{RP}	\overline{RESET} Pulse Width (n/a for EN29F002N)	Min	500	500	500	500	ns
	t_{RSP}	\overline{RESET} Setup Time (n/a for EN29F002N)	Min	4	4	4	4	μ s

**Table 10. AC CHARACTERISTICS
Write (Erase/Program) Operations**

 Alternate \overline{CE} Controlled Writes

Parameter Symbols		Description		Speed Options				Unit
JEDEC	Standard			-45	-55	-70	-90	
t_{AVAV}	t_{WC}	Write Cycle Time	Min	45	55	70	90	ns
t_{AVEL}	t_{AS}	Address Setup Time	Min	0	0	0	0	ns
t_{ELAX}	t_{AH}	Address Hold Time	Min	35	45	45	45	ns
t_{DVEH}	t_{DS}	Data Setup Time	Min	20	25	30	45	ns
t_{EHDX}	t_{DH}	Data Hold Time	Min	0	0	0	0	ns
	t_{OES}	Output Enable Setup Time	Min	0	0	0	0	ns
	t_{OEH}	Output Enable Hold Time	Read	0	0	0	0	ns
		Toggle and Data Polling	10	10	10	10	10	ns
t_{GHEL}	t_{GHEL}	Read Recovery Time before Write (\overline{OE} High to \overline{CE} Low)	Min	0	0	0	0	ns
t_{WLEL}	t_{WS}	\overline{WE} Setup Time	Min	0	0	0	0	ns
t_{EHWH}	t_{WH}	\overline{WE} Hold Time	Min	0	0	0	0	ns
t_{ELEH}	t_{CP}	Write Pulse Width	Min	25	30	35	45	ns
t_{EHEL}	t_{CPH}	Write Pulse Width High	Min	20	20	20	20	ns
t_{WHWH1}	t_{WHWH1}	Programming Operation	Typ	7	7	7	7	μ s
			Max	200	200	200	200	μ s
t_{WHWH2}	t_{WHWH2}	Sector Erase Operation	Typ	0.3	0.3	0.3	0.3	s
			Max	5	5	5	5	s
t_{WHWH3}	t_{WHWH3}	Chip Erase Operation	Typ	3	3	3	3	s
			Max	35	35	35	35	s
	t_{VCS}	Vcc Setup Time	Min	50	50	50	50	μ s
	t_{VIDR}	Rise Time to V_{ID}	Min	500	500	500	500	ns
	t_{RP}	\overline{RESET} Pulse Width (n/a for EN29F002N)	Min	500	500	500	500	ns
	t_{RSP}	\overline{RESET} Setup Time (n/a for EN29F002N)	Min	4	4	4	4	μ s

Table 11. ERASE AND PROGRAMMING PERFORMANCE

Parameter	Limits			Comments
	Typ	Max	Unit	
Sector Erase Time	0.3	5	sec	Excludes 00H programming prior to erasure
Chip Erase Time	3	35	sec	
Byte Programming Time	7	200	µs	Excludes system level overhead
Chip Programming Time	2	5	sec	
Erase/Program Endurance	100K		cycles	Minimum 100K cycles guaranteed

Table 12. LATCH UP CHARACTERISTICS

Parameter Description	Min	Max
Input voltage with respect to V _{ss} on A9 and \overline{OE} , and \overline{RESET}	-1.0 V	12.0 V
Input voltage with respect to V _{ss} on all other pins	-1.0 V	V _{cc} + 1.0 V
V _{cc} Current	-100 mA	100 mA

Note : These are latch up characteristics and the device should never be put under these conditions. Refer to Absolute Maximum ratings for the actual operating limits.

Table 13. 32-PIN PLCC PIN CAPACITANCE @ 25°C, 1.0MHz

Parameter Symbol	Parameter Description	Test Setup	Typ	Max	Unit
C _{IN}	Input Capacitance	V _{IN} = 0	4	6	pF
C _{OUT}	Output Capacitance	V _{OUT} = 0	8	12	pF
C _{IN2}	Control Pin Capacitance	V _{IN} = 0	8	12	pF

Table 14. 32-PIN TSOP PIN CAPACITANCE @ 25°C, 1.0MHz

Parameter Symbol	Parameter Description	Test Setup	Typ	Max	Unit
C _{IN}	Input Capacitance	V _{IN} = 0	6	7.5	pF
C _{OUT}	Output Capacitance	V _{OUT} = 0	8.5	12	pF
C _{IN2}	Control Pin Capacitance	V _{IN} = 0	7.5	9	pF

Table 15. DATA RETENTION

Parameter Description	Test Conditions	Min	Unit
Minimum Pattern Data Retention Time	150°C	10	Years
	125°C	20	Years

SWITCHING WAVEFORMS

Figure 5. AC Waveforms for READ Operations

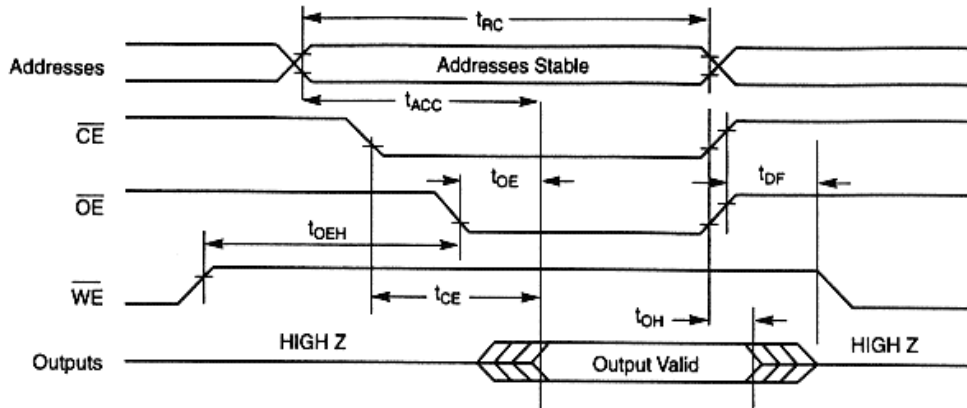
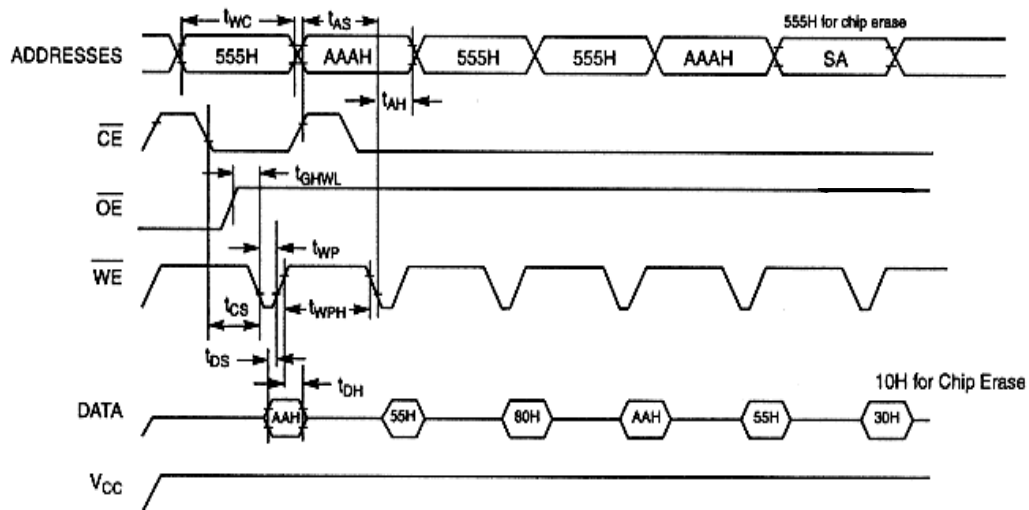

Figure 6. AC Waveforms for Chip/Sector Erase Operations



Notes:

1. SA is the sector address for sector erase.

SWITCHING WAVEFORMS (continued)

Figure 7. Program Operation Timings

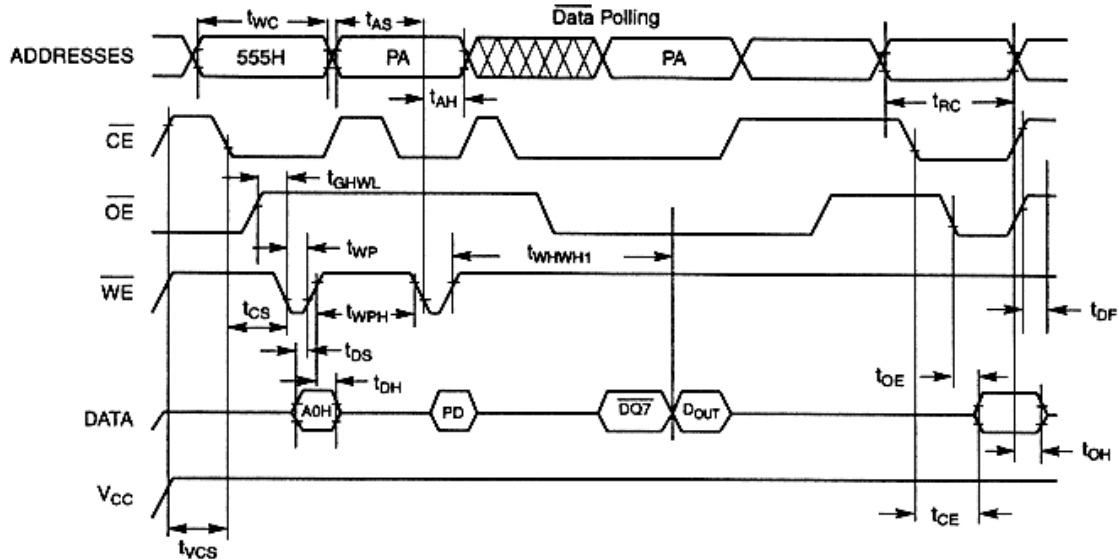

Notes:

1. PA is address of the memory location to be programmed.
2. PD is data to be programmed at byte address.
3. /DQ7 is the output of the complement of the data written to the device.
4. D_{OUT} is the output of data written to the device.
5. Figure indicates last two bus cycles of four bus cycle sequence.

Figure 8. AC Waveforms for /DATA Polling During Embedded Algorithm Operations

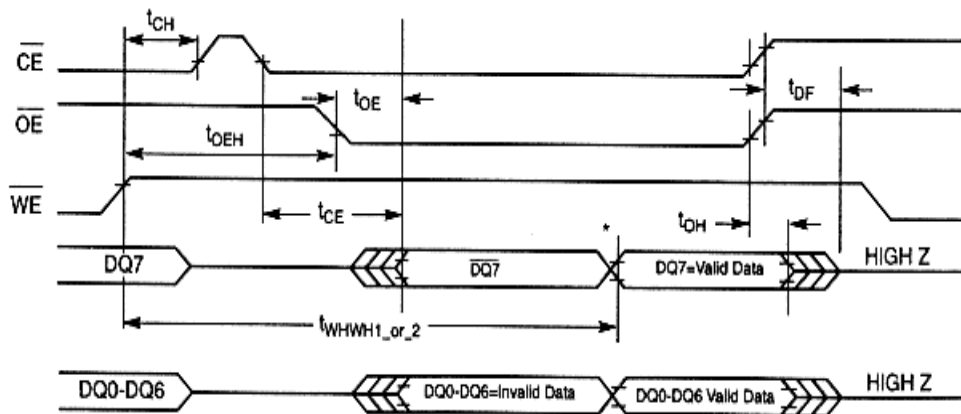

Notes:

- *DQ₇ = Valid Data (The device has completed the embedded operation).

Figure 9. AC Waveforms for Toggle Bit During Embedded Algorithm Operations

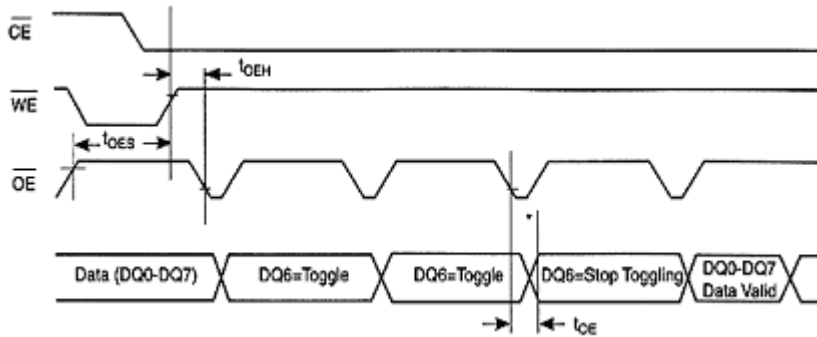

Notes:

* DQ_6 stops toggling (The device has completed the embedded operation).

Figure 10. Temporary Sector Unprotect Timing Diagram

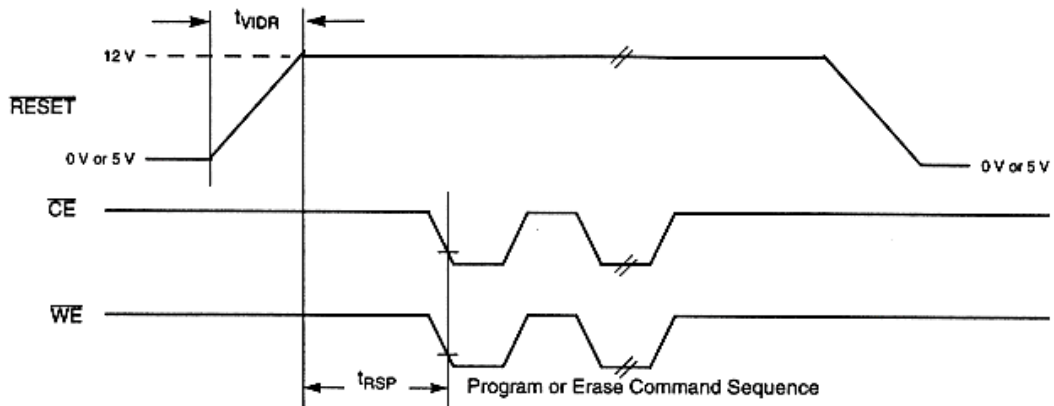

SWITCHING WAVEFORMS (continued)

Figure 11. /RESET Timing Diagram

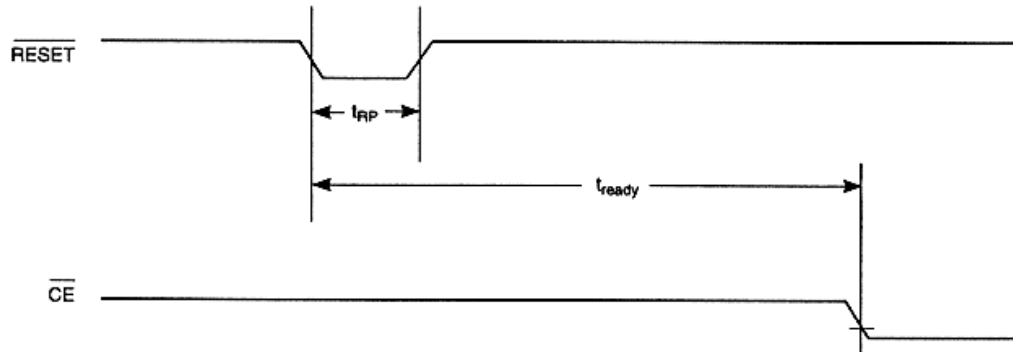
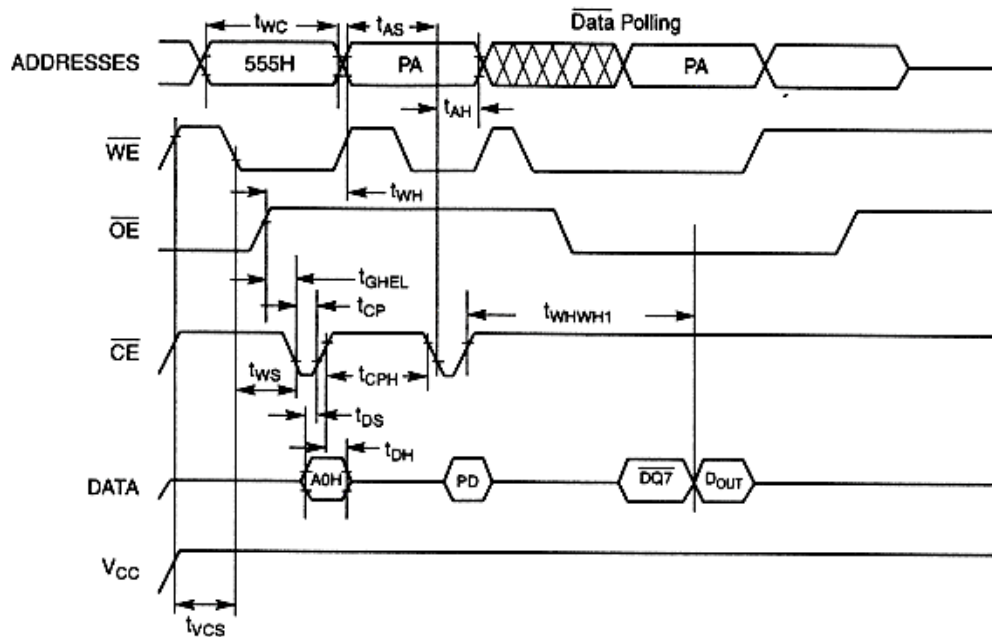

Figure 12. Alternate /CE Controlled Write Operation Timings



Notes:

1. PA is address of the memory location to be programmed.
2. PD is data to be programmed at byte address.
3. /DQ7 is the output of the complement of the data written to the device.
4. D_{OUT} is the output of data written to the device.
5. Figure indicates last two bus cycles of four bus cycle sequence.

ORDERING INFORMATION

EN29F002 T - 45 P I

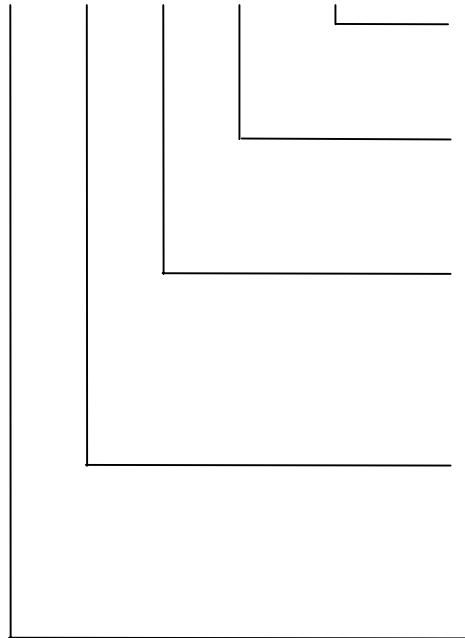
**TEMPERATURE RANGE**

(Blank) = Commercial (0°C to +70°C)

I = Industrial (-40°C to +85°C)

PACKAGE

P = 32 Plastic DIP

J = 32 Plastic PLCC

T = 32 Plastic TSOP

SPEED

45 = 45ns

55 = 55ns

70 = 70ns

90 = 90ns

BOOT BLOCK ARCHITECTURE

T = Top Block

B = Bottom Block

BASE PART NUMBER

EN = EON Silicon Devices

29F = FLASH, 5V

002 = 256K x 8

(Blank) = with RESET functionN = without RESET function

Revisions List

A:

Preliminary

B (2001.07.03):

Table 7. Icc3 is with RESET# pin at full CMOS levels

Pg. 13 Logical Inhibit section now says that if \overline{CE} , \overline{WE} , and \overline{OE} are all logical zero (not recommended usage), it will be considered a write.

VID is everywhere changed to be $V_{ID} = 11.5 \pm 0.5V$

C (2001.07.05):

VID is everywhere changed to be $V_{ID} = 11.0 \pm 0.5V$

“block” changed to “sector” everywhere appropriate.

Deleted Sector Un/Protect flow charts (we have a supplement for that)

RESET# = VID and not VPP on first page.

LACTHUP \geq 200mA line removed from first page

Chip erase and Sector Erase command descriptions modified.

DQ7,DQ5,DQ3 status polling descriptions modified.

Table 7 and Table 12 modified

Absolute Maximum Ratings section added