

---

**82C931**

**Plug and Play  
Integrated Audio Controller**

**Data Book**

912-3000-035  
Revision: 2.1  
August 1, 1997

---

---

## Copyright

Copyright © 1996, OPTi Inc. All rights reserved. No part of this publication may be reproduced, transmitted, transcribed, stored in a retrieval system, or translated into any language or computer language, in any form or by any means, electronic, mechanical, magnetic, optical, chemical, manual, or otherwise, without the prior written permission of OPTi Incorporated, 888 Tasman Drive, Milpitas, CA 95035.

## Disclaimer

OPTi Inc. makes no representations or warranties with respect to the design and documentation herein described and especially disclaims any implied warranties of merchantability or fitness for any particular purpose. Further, OPTi Inc. reserves the right to revise the design and associated documentation and to make changes from time to time in the content without obligation of OPTi Inc. to notify any person of such revisions or changes.

## Trademarks

OPTi and OPTi Inc. are registered trademarks of OPTi Incorporated.

All other trademarks and copyrights are the property of their respective holders.

### **OPTi Inc.**

888 Tasman Drive  
Milpitas, CA 95035  
Tel: (408) 486-8000  
Fax: (408) 486-8001  
WWW: <http://www.opti.com/>

---

# Table of Contents

<b>1.0</b>	<b>Features</b> .....	<b>1</b>
<b>2.0</b>	<b>Overview</b> .....	<b>3</b>
<b>3.0</b>	<b>Signal Definitions</b> .....	<b>5</b>
<b>3.1</b>	<b>Mode Selection</b> .....	<b>5</b>
<b>3.2</b>	<b>931-MB Mode</b> .....	<b>6</b>
3.2.1	931-MB Mode Signal Descriptions .....	8
3.2.1.1	ISA Bus Interface Signals .....	8
3.2.1.2	MIDI Interface Signals.....	8
3.2.1.3	Configuration and External PnP EEPROM Interface Signals .....	9
3.2.1.4	Game Port and Serial Audio Interface Signals .....	9
3.2.1.5	Codec/Mixer Interface Signals .....	10
3.2.1.6	Power and Ground Pins .....	11
<b>3.3</b>	<b>931-AD Mode</b> .....	<b>12</b>
3.3.1	931-AD Mode Signal Descriptions.....	14
3.3.1.1	ISA Bus Signals .....	14
3.3.1.2	MIDI Interface Signals.....	14
3.3.1.3	Configuration, External PnP EEPROM, and IDE CD-ROM Interface Signals.....	15
3.3.1.4	Game Port and Modem Interface Signals .....	16
3.3.1.5	Codec/Mixer Interface Signals .....	16
3.3.1.6	Serial Audio Interface Signals.....	17
3.3.1.7	Power and Ground Pins .....	17
<b>4.0</b>	<b>Functional Description</b> .....	<b>19</b>
<b>4.1</b>	<b>Plug and Play</b> .....	<b>19</b>
<b>4.2</b>	<b>16-Bit Codec/Mixer</b> .....	<b>20</b>
4.2.1	Codec .....	20
4.2.2	Mixer.....	21
<b>4.3</b>	<b>Frequency Synthesizer</b> .....	<b>22</b>
<b>4.4</b>	<b>16-Bit Type F DMA Playback</b> .....	<b>23</b>
<b>4.5</b>	<b>Modem Interface</b> .....	<b>23</b>
<b>4.6</b>	<b>Push Button Volume Control</b> .....	<b>23</b>
<b>4.7</b>	<b>External Serial EEPROM</b> .....	<b>23</b>
<b>4.8</b>	<b>Serial Audio Interface</b> .....	<b>23</b>
4.8.1	I2S-justified format and its variations.....	23
4.8.2	Sony format .....	24



## Table of Contents (cont.)

4.8.3	AT&T PCM codec T7525 compatible 16-bit mono format .....	24
4.8.4	Testing I2S format (ZV port) with Audio Precision machine .....	24
4.8.5	Relevant MC register settings .....	24
4.8.6	ZV-Port I2S.....	25
4.8.6.1	LRCLK .....	25
4.8.6.2	SDATA .....	25
4.8.6.3	SCLK.....	26
4.8.6.4	MCLK.....	26
4.8.7	Advanced Precision General Purpose Serial Port.....	26
4.8.8	TDA1311 Stereo Continuous Calibration .....	27
<b>5.0</b>	<b>Register Descriptions .....</b>	<b>29</b>
5.1	I/O Base Addresses .....	29
5.2	MCBase Register .....	29
5.3	SBase Register .....	36
5.4	WBase Register .....	37
<b>6.0</b>	<b>Electrical Specifications.....</b>	<b>45</b>
6.1	Absolute Maximum Ratings.....	45
6.2	DC Characteristics: 5.0 Volt (VCC = 5.0V ±5%, TA = 0°C to +70°C).....	45
6.3	General Specifications: 5.0 Volt (VCC = 5.0V ±5%, TA = 0°C to +70°C).....	46
6.4	Pin Specifications - Analog (VCC = 5.0V, 25×C) .....	47
6.5	Volume Setting.....	47
6.6	Analog Characteristics.....	47
6.6.1	Analog Inputs.....	48
6.6.2	Analog Outputs (10kW, 25pF) .....	48
6.6.3	Volume Settings .....	48
6.6.4	Analog-to-Digital Converters .....	49
6.6.5	Digital-to-Analog Converters .....	49
6.7	AC Timings.....	49
<b>7.0</b>	<b>Mechanical Packages .....</b>	<b>53</b>

---

## List of Figures

---

Figure 1-1	System Block Diagram .....	1
Figure 2-1	Functional Block Diagram.....	3
Figure 2-2	Data Flow Block Diagram .....	4
Figure 3-1	931-MB Mode PQFP Pin Diagram.....	6
Figure 3-2	931-AD Mode PQFP Pin Diagram .....	12
Figure 4-1	Functional Block Diagram.....	20
Figure 4-2	Mixer Block Diagram .....	21
Figure 4-3	I2S Format .....	25
Figure 4-4	General Purpose Serial Port, Timing Relationships .....	26
Figure 4-5	Format of Input Signals .....	27
Figure 6-1	RESET and CLK Timing Waveform.....	50
Figure 6-2	CD-ROM I/O Read Cycle.....	51
Figure 6-3	CD-ROM I/O Write Cycle.....	51
Figure 6-4	DMA Write/Playback Cycle.....	52
Figure 6-5	DMA Read/Capture Cycle .....	52
Figure 7-1	100-pin PQFP, Plastic Quad Flat Pack .....	53
Figure 7-2	100-pin TQFP, Thin Quad Flat Package .....	54



---

## List of Tables

---

Table 3-1	Mode Selection .....	5
Table 3-2	Mode Features .....	5
Table 3-3	Signal Definitions Legend .....	5
Table 3-4	931-MB Mode Numerical Pin Cross-Reference List .....	7
Table 3-5	931-MB Mode Alphabetical Pin Cross-Reference List .....	7
Table 3-6	931-AD Mode Numerical Pin Cross-Reference List .....	13
Table 3-7	931-AD Mode Alphabetical Pin Cross-Reference List .....	13
Table 4-1	FS Output Frequencies .....	22
Table 5-1	82C931 I/O Base Addresses .....	29
Table 5-2	82C931 Register Map .....	29
Table 5-3	MCBase, Direct MC Register .....	30
Table 5-4	McBase, Index (MCIndx) and Data (MCData) Ports Address Range .....	30
Table 5-5	MCIdx and MCData Registers .....	30
Table 5-6	MC Indirect Registers .....	31
Table 5-7	SBBase Registers for FM and DAP Applications .....	36
Table 5-8	WSBase Registers for Windows Sound System Applications .....	37
Table 5-9	WSBase Register for Codec/Mixer Applications .....	38
Table 5-10	Codec Indirect Registers .....	40
Table 5-11	Expanded Mode CIR .....	43





# Plug and Play Integrated Audio Controller

## 1.0 Features

- Integrated sound controller compatible with:
  - Sound Blaster Pro™
  - Ad Lib™
  - Microsoft® Windows™ Sound System™
- Microsoft® PC-97 compliant
- Built-in high-quality 22 voice, 52 operator, OPTiFM™ music synthesizer with enhanced bass
- Built-in 7-channel mixer: five stereo, two mono
- Built-in 16-bit sigma-delta stereo codec
- ISA Plug and Play Specification 1.0a compatible, supports a maximum of six logical devices:
  - Sound Blaster Pro, Windows Sound System, FM synthesis
  - MPU-401 MIDI interface
  - CD-ROM interface
  - Joystick/game port
  - Modem interface
  - 82C931 control
- Supports external serial EEPROM (optional)
- External modem chipset interface
- Full duplex operation: record and playback simultaneously using two 8- or 16-bit DMA channels
- Supports IMA ADPCM,  $\mu$ -law, A-law decompression
- 8- or 16-bit stereo sound data up to 48KHz stereo
- Supports 16-bit Type F DMA playback, accelerates telephony-audio applications
- Digital joystick interface support, improves responsiveness (Microsoft SideWinder™)
- I<sup>2</sup>S serial interface supports Zoom Video Port, wavetable controller and modem chipset
- DirectSound™ interface support
- Power-down modes
- Silence mode to turn-off all audio functions
- Hardware and software volume control via push-button interface
- 100-pin PQFP (Plastic Quad Flat Pack)
- 100-pin TQFP (Thin Quad Flat Pack)

Figure 1-1 System Block Diagram

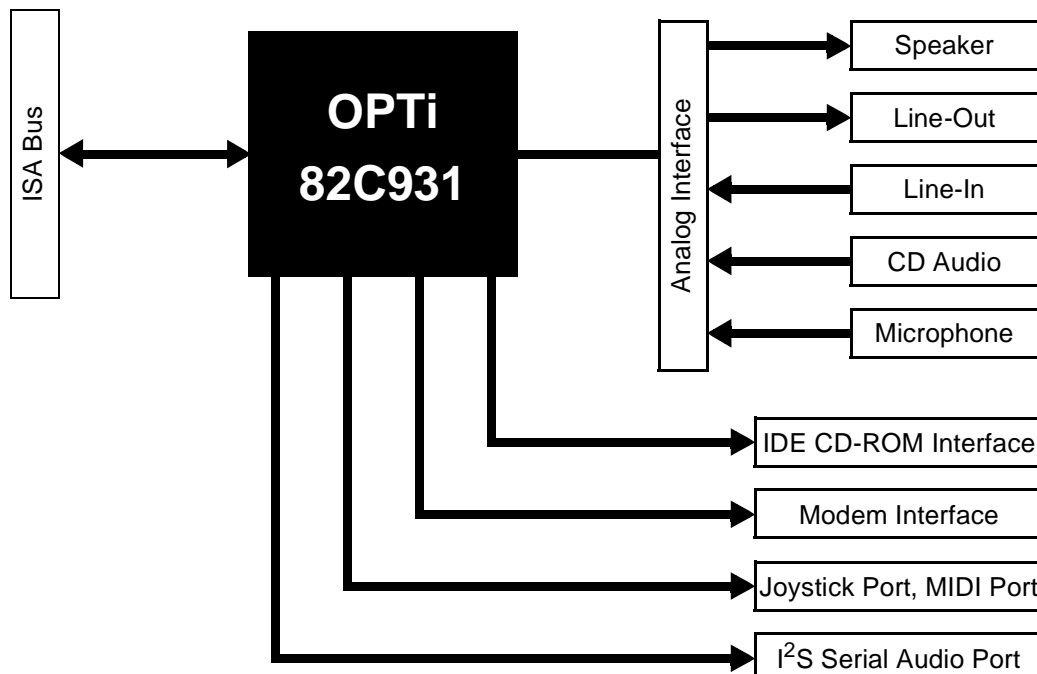



## 2.0 Overview

The OPTi 82C931 is a single-chip Plug-and-Play audio system controller and codec that provides compatibility with Sound Blaster Pro™, Microsoft Windows Sound System™, OPL3, and MPU-401 interfaces. The 82C931 integrates a 16-bit stereo sigma-delta codec and PC-97 compliant internal resource structure. This provides an effective audio solution for Windows 95 operating systems, DirectSound™, and advanced audio applications.

The 82C931 provides front panel push-button volume control, external modem chip interface, serial EEPROM for further customizing, support for 16-bit Type F DMA playback and an I<sup>2</sup>S serial interface to a Zoom Video Port, wavetable controller, or modem chipset.

The 82C931 includes the following functions: ISA bus interface, Sound Blaster Pro-compatible Digital Audio Processor,

MIDI interface, Windows Sound System interface, FM synthesizer interface, 16-bit codec/mixer, game port timer, and IDE CD-ROM interface. The device also includes dual DMA channels that support full duplex operation for simultaneous record and playback, a silence mode, power-down modes, and software programmable interrupts. (Figure 2-1 shows a functional block diagram of the 82C931. Figure 2-2 shows the 82C931 data flow block diagram.)

The 82C931 Integrated Audio Controller provides all of the functions and interfaces for Sound Blaster Pro-compatible and Microsoft Windows Sound System-compatible cards. The 82C931 is intended to provide an integrated audio solution for business audio, educational/entertainment sound, and multimedia applications.

**Figure 2-1 Functional Block Diagram**

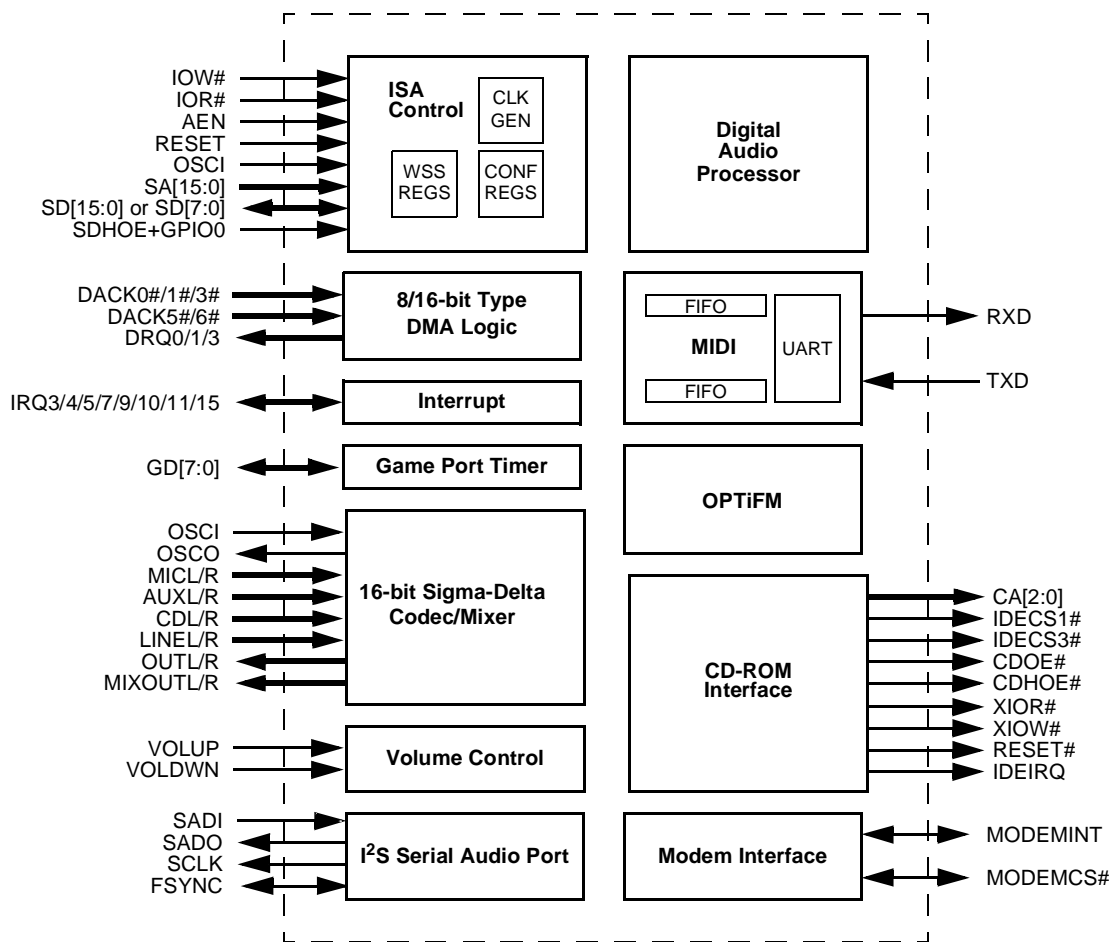

**Figure 2-2 Data Flow Block Diagram**

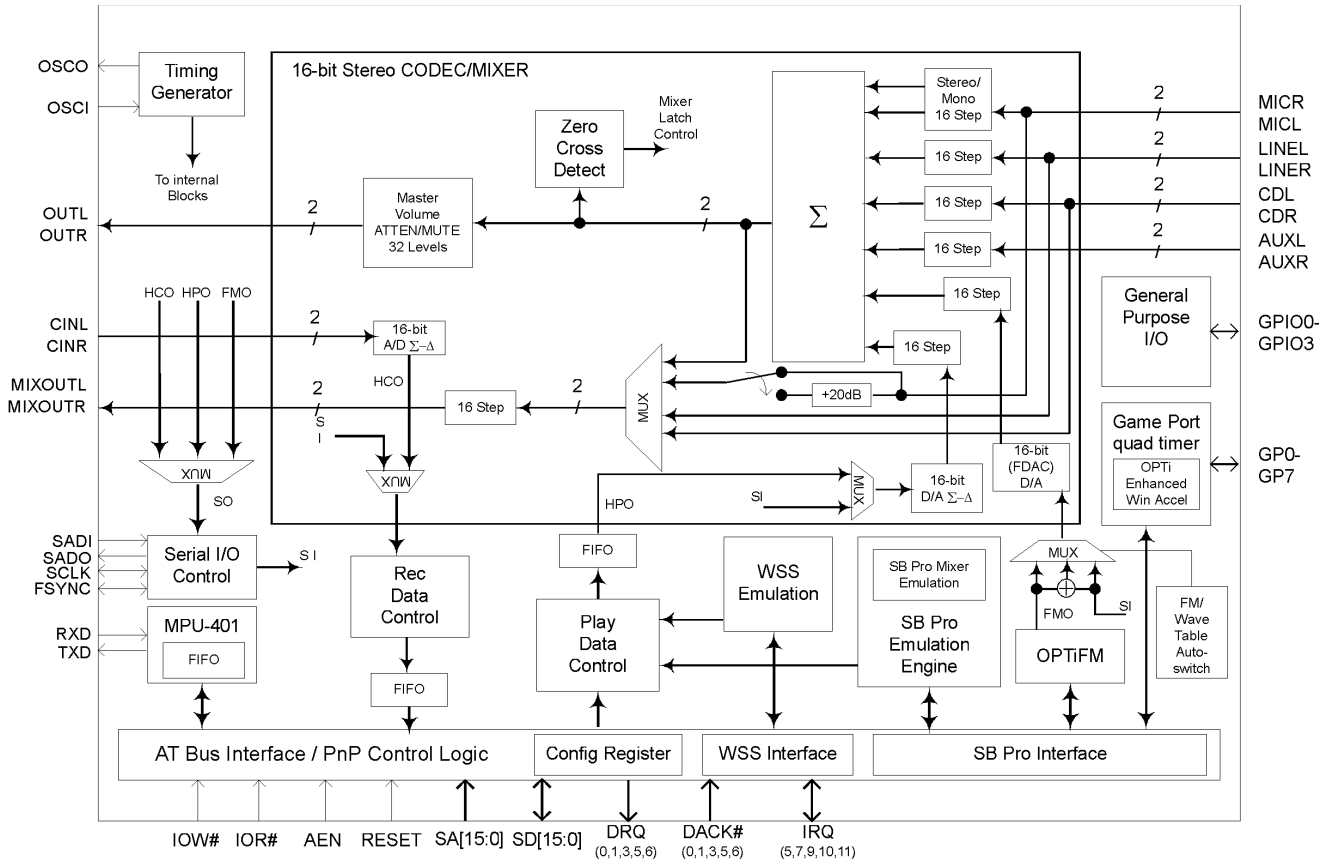

**Note:** There are four signals which are referenced by acronyms to make connections within the block diagram.

- HCO = Host Capture Output
- HPO = Host Playback Output
- FMO = FM Output
- SI = Serial In
- SO = Serial Out



## 3.0 Signal Definitions

### 3.1 Mode Selection

The 82C931 can be configured into two different modes:

- 931-MB Mode
  - Single-chip motherboard application with 16-bit DMA support to enhance telephony-audio application performance.
- 931-AD Mode
  - Single chip adaptor card with support for IDE CD-ROM and modem interfaces.

Pin 11 is used to select the desired mode of the 82C931 (as shown in Table 3-1). Table 3-2 details the features in both of these modes.

**Table 3-1 Mode Selection**

Pin 11	Mode
1	931-MB
0	931-AD

**Table 3-2 Mode Features**

Feature	931-MB	931-AD <sup>(4)</sup>
IDE CD Interface	No	Yes
IDE Interrupt Redirect	No	Yes
Modem Interface	No	Yes <sup>(1)</sup>
Volume Control	Yes <sup>(2)</sup>	Yes <sup>(2)</sup>
Serial Audio Port	Yes <sup>(3)</sup>	Yes
Internal OPTiFM	Yes	Yes
16-Bit DMA	Yes	No

1. Pins are shared between second Game Port and Modem interface.
2. Volume Control can be used when second Game Port is not used by others.
3. Pins are shared between second Game Port and Serial Audio port.
4. The IDE and modem resources are programmable in 931-AD mode (available in 931 silicon revision 1.1 only).

Some pins of the 82C931 take on different functions depending upon its configured mode. The following subsections give the pin assignment and definitions for both the 931-MB and 931-AD modes, respectively.

In addition to mode defined pins, the 82C931 has multiplexed pins. These pins are denoted with a plus (+) sign between signal names. Their definitions can also be found in the signal description tables.

Table 3-3 defines abbreviated terms that are used throughout this section.

**Table 3-3 Signal Definitions Legend**

Mnemonic	Description
Analog	Analog-level compatible
CMOS	CMOS-level compatible
Ext	External
G	Ground
I	Input
Int	Internal
I/O	Input/Output
Mux	Multiplexer
O	Output
OD	Open drain
P	Power
PD	Pull-down resistor
PU	Pull-up resistor
Smt	Schmitt-trigger
TS	Tristate
TTL	TTL-level compatible

# 82C931

## 3.2 931-MB Mode

Figure 3-1 931-MB Mode PQFP Pin Diagram \*

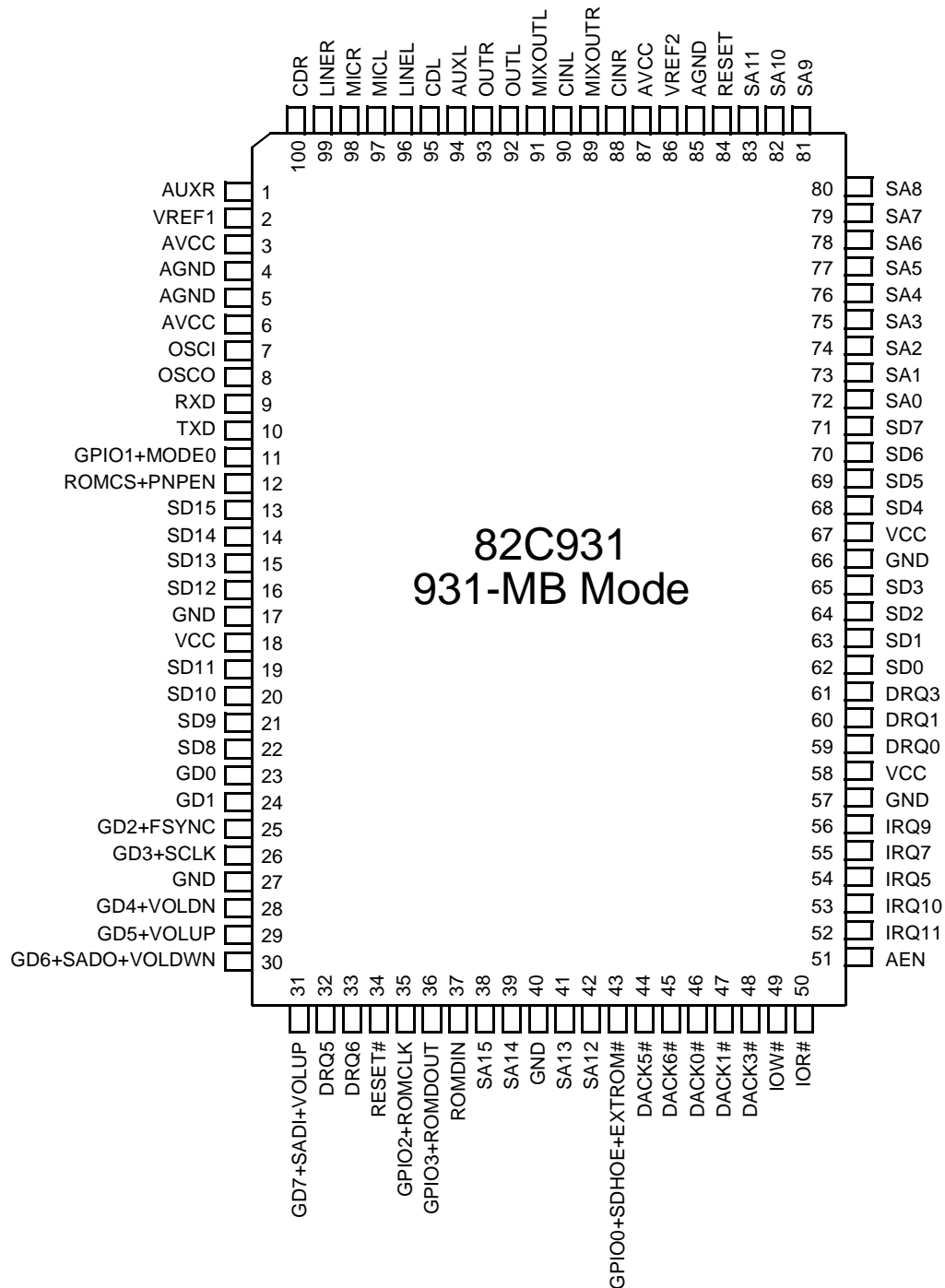

\* Pinout for TQFP Package is identical to pinout for PQFP Package.



Table 3-4 931-MB Mode Numerical Pin Cross-Reference List

Pin No.	Pin Name	Pin Type	Pin No.	Pin Name	Pin Type	Pin No.	Pin Name	Pin Type	Pin No.	Pin Name	Pin Type
1	AUXR	I	26	GD3+SCLK	I/O	51	AEN	I	76	SA4	I
2	VREF1	O	27	GND	G	52	IRQ11	I/O	77	SA5	I
3	AVCC	P	28	GD4+VOLDN	I/O	53	IRQ10	I/O	78	SA6	I
4	AGND	G	29	GD5+VOLUP	I/O	54	IRQ5	I/O	79	SA7	I
5	AGND	G	30	GD6+SADO+VOLDWN	I/O	55	IRQ7	I/O	80	SA8	I
6	AVCC	P	31	GD7+SADI+VOLUP	I/O	56	IRQ9	I/O	81	SA9	I
7	OSCI	I	32	DRQ5	O-TS	57	GND	G	82	SA10	I
8	OSCO	O	33	DRQ6	O-TS	58	VCC	P	83	SA11	I
9	RXD	I	34	RESET#	O	59	DRQ0	O-TS	84	RESET	I
10	TXD	O	35	GPIO2+ROMCLK	I/O	60	DRQ1	O-TS	85	AGND	G
11	GPIO1+MODE0	I/O	36	GPIO3+ROMDOUT	I/O	61	DRQ3	O-TS	86	VREF2	O
12	ROMCS+PNPEN	I/O	37	ROMDIN	I/O	62	SD0	I/O	87	AVCC	P
13	SD15	I/O	38	SA15	I	63	SD1	I/O	88	CINR	I
14	SD14	I/O	39	SA14	I	64	SD2	I/O	89	MIXOUTR	O
15	SD13	I/O	40	GND	G	65	SD3	I/O	90	CINL	I
16	SD12	I/O	41	SA13	I	66	GND	G	91	MIXOUTL	O
17	GND	G	42	SA12	I	67	VCC	P	92	OUTL	O
18	VCC	P	43	GPIO0+SDHOE +EXTROM#	I/O	68	SD4	I/O	93	OUTR	O
19	SD11	I/O	44	DACK5#	I	69	SD5	I/O	94	AUXL	I
20	SD10	I/O	45	DACK6#	I	70	SD6	I/O	95	CDL	I
21	SD9	I/O	46	DACK0#	I	71	SD7	I/O	96	LINEL	I
22	SD8	I/O	47	DACK1#	I	72	SA0	I	97	MICL	I
23	GD0	I/O	48	DACK3#	I	73	SA1	I	98	MICR	I
24	GD1	I/O	49	IOW#	I	74	SA2	I	99	LINER	I
25	GD2+FSYNC	I/O	50	IOR#	I	75	SA3	I	100	CDR	I

Table 3-5 931-MB Mode Alphabetical Pin Cross-Reference List

Pin Name	Pin No.	Pin Type	Pin Name	Pin No.	Pin Type	Pin Name	Pin No.	Pin Type	Pin Name	Pin No.	Pin Type
AEN	51	I	GD2+FSYNC	25	I/O	MICR	98	I	SA13	41	I
AGND	4	G	GD3+SCLK	26	I/O	MIXOUTL	91	O	SA14	39	I
AGND	5	G	GD4+VOLDN	28	I/O	MIXOUTR	89	O	SA15	38	I
AGND	85	G	GD5+VOLUP	29	I/O	OSCI	7	I	SD0	62	I/O
AUXL	94	I	GD6+SADO+VOLDWN	30	I/O	OSCO	8	O	SD1	63	I/O
AUXR	1	I	GD7+SADI+VOLUP	31	I/O	OUTL	92	O	SD2	64	I/O
AVCC	3	P	GND	17	G	OUTR	93	O	SD3	65	I/O
AVCC	6	P	GND	27	G	RESET	84	I	SD4	68	I/O
AVCC	87	P	GND	40	G	RESET#	34	O	SD5	69	I/O
CDL	95	I	GND	57	G	ROMCS+PNPEN	12	I/O	SD6	70	I/O
CDR	100	I	GND	66	G	ROMDIN	37	I/O	SD7	71	I/O
CINL	90	I	GPIO0+SDHOE +EXTROM#	43	I/O	RXD	9	I	SD8	22	I/O
CINR	88	I	GPIO1+MODE0	11	I/O	SA0	72	I	SD9	21	I/O
DACK0#	46	I	GPIO2+ROMCLK	35	I/O	SA1	73	I	SD10	20	I/O
DACK1#	47	I	GPIO3+ROMDOUT	36	I/O	SA2	74	I	SD11	19	I/O
DACK3#	48	I	IOW#	49	I	SA3	75	I	SD12	16	I/O
DACK5#	44	I	IOR#	50	I	SA4	76	I	SD13	15	I/O
DACK6#	45	I	IRQ5	54	I/O	SA5	77	I	SD14	14	I/O
DRQ0	59	O-TS	IRQ7	55	I/O	SA6	78	I	SD15	13	I/O
DRQ1	60	O-TS	IRQ9	56	I/O	SA7	79	I	TXD	10	O
DRQ3	61	O-TS	IRQ10	53	I/O	SA8	80	I	VCC	18	P
DRQ5	32	O-TS	IRQ11	52	I/O	SA9	81	I	VCC	58	P
DRQ6	33	O-TS	LINEL	96	I	SA10	82	I	VCC	67	P
GD0	23	I/O	LINER	99	I	SA11	83	I	VREF1	2	O
GD1	24	I/O	MICL	97	I	SA12	42	I	VREF2	86	O



## 3.2.1 931-MB Mode Signal Descriptions

### 3.2.1.1 ISA Bus Interface Signals

Signal Name	Pin No.	Signal/Pin Type (Drive)	Signal Description
IOW#	49	I-TTL-Smt, 50KΩ PU	<i>I/O Write Command</i>
IOR#	50	I-TTL-Smt, 50KΩ PU	<i>I/O Read Command</i>
AEN	51	I-TTL-Smt	<i>DMA Address Enable</i>
RESET	84	I-TTL-Smt, 50KΩ PD	<i>System Reset Input</i>
SA[15:0]	38, 39, 41, 42, 83:72	I-TTL	<i>System Address Bus Lines 15 through 0</i>
SD[15:8]	13:16, 19:22	I/O-TTL (12mA)	<i>System Data Bus Lines 15 through 8</i>
SD[7:0]	71:68, 65:62	I/O-TTL (16mA)	<i>System Data Bus Lines 7 through 0</i>
DACK0# DACK1# DACK3#	46 47 48	I-TTL, 50KΩ PU	<i>8-Bit DMA Acknowledge Bits 0, 1, and 3</i>
DRQ0 DRQ1 DRQ3	59 60 61	O-TS (12mA), 50KΩ PD	<i>8-Bit DMA Request Bits 0, 1, and 3</i>
DACK5# DACK6#	44 45	I-TTL	<i>16-Bit DMA Acknowledge Bits 5 and 6</i>
DRQ5 DRQ6	32 33	O-TS (12mA)	<i>16-Bit DMA Request Bits 5 and 6</i>
IRQ5 IRQ7 IRQ9 IRQ10 IRQ11	54 55 56 53 52	OD-I/O-TTL (12mA)	<i>Interrupt Request Bits 5, 7, and 9 through 11: IRQ7 and IRQ9-11 are bidirectional for WSS auto interrupt determination.</i>

### 3.2.1.2 MIDI Interface Signals

Signal Name	Pin No.	Signal/Pin Type (Drive)	Signal Description
RXD	9	I-TTL-Smt	<i>Receive Data from 32KBaud MIDI UART Port</i>
TXD	10	O (20mA)	<i>Transmit Data to 32KBaud MIDI UART Port</i>



## 931-MB Mode Signal Descriptions (cont.)

## 3.2.1.3 Configuration and External PnP EEPROM Interface Signals

Signal Name	Pin No.	Signal/Pin Type (Drive)	Signal Description
ROMCS	12	I/O-TTL, PU (8mA)	<b>External Serial EEPROM Chip Select</b>
PNPEN			<b>PNP Mode Enable Jumper Input:</b> Jumper setting is latched at reset power-on reset. This pin has an internal pull-up. Jumper pull-up: enable (default), pull-down: disable
GPIO1	11	I/O-TTL, PU (8mA)	<b>General Purpose Input/Output</b>
MODE0			<b>931 Mode Configuration Bit 0:</b> This pin is used to configure the 82C931 in either the 931-MB or 931-AD mode (refer to Table 3-1). These settings are latched into the 82C931 at reset.
GPIO2	35	I/O-TTL, PD (12mA)	<b>General Purpose Input/Output</b>
ROMCLK			<b>External Serial EEPROM Clock</b>
GPIO3	36	I/O-TTL, PU (12mA)	<b>General Purpose Input/Output</b>
ROMDOUT			<b>External Serial EEPROM Data Out</b>
ROMDIN	37	I/O-TTL, PD (12mA)	<b>External Serial EEPROM Data In</b> EEPROM enable jumper input function is removed
RESET#	34	O (12mA)	<b>Buffered Reset</b> (active low)
GPIO0	43	I/O-TTL, PU (8mA)	<b>General Purpose I/O Bit 0</b>
SDHOE			<b>SD[15:8] Buffer Output Enable:</b> Set MCIR19[7] = 1 to enable SDHOE function on this pin.
EXTROM			<b>External EEPROM enable jumper input:</b> jumper setting is latched at power-on reset. This pin has internal pull-up. Jumper pull-up: disable (default), pull-down: enable

## 3.2.1.4 Game Port and Serial Audio Interface Signals

Signal Name	Pin No.	Signal/Pin Type (Drive)	Signal Description
GD7	31	I/O-CMOS-Smt (8mA)	<b>Game Port 2 Data Line 7</b>
SADI			<b>Serial Audio Data Input</b>
VOLUP			<b>Volume Up:</b> Interface for push-button volume control. Used to increase volume. An external pull-up is required on this pin.
GD6	30	I/O-CMOS-Smt (16mA)	<b>Game Port 2 Data Line 6</b>
SADO			<b>Serial Audio Data Output</b>
VOLDWN			<b>Volume Down:</b> Interface for push-button volume control. Used to decrease volume. An external pull-up is required on this pin.
GD5	29	I/O-CMOS (8mA)	<b>Game Port 1 Data Line 5</b> An External pull-up is required on this pin.
VOLUP			<b>Volume Up:</b> Interface for push-button volume control. Used to increase volume. VOLUP on pin 29 is only available in rev. 1.1 silicon.

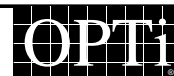

## 931-MB Mode Signal Descriptions (cont.)

### 3.2.1.4 Game Port and Serial Audio Interface Signals

Signal Name	Pin No.	Signal/Pin Type (Drive)	Signal Description
GD4	28	I/O-CMOS (8mA)	<b>Game Port 1 Data Line 4</b> An External pull-up is required on this pin.
VOLDN			<b>Volume Down:</b> Interface for push-button volume control. Used to decrease volume. VOLDN on pin 28 is only available in rev. 1.1 silicon.
GD3	26	I/O-CMOS (8mA)	<b>Game Port 2 Data Line 3</b>
SCLK			<b>Serial Audio Clock</b>
GD2	25	I/O-CMOS (8mA)	<b>Game Port 2 Data Line 2</b>
FSYNC			<b>Serial Audio Synchronization</b>
GD1	24	I/O-CMOS (8mA)	<b>Game Port 1 Data Line 1</b>
GD0	23	I/O-CMOS (8mA)	<b>Game Port 1 Data Line 0</b>

### 3.2.1.5 Codec/Mixer Interface Signals

Signal Name	Pin No.	Signal/Pin Type (Drive)	Signal Description
MICL	97	I-Analog	<b>Microphone Input Left</b>
MICR	98	I-Analog	<b>Microphone Input Right</b>
LINEL	96	I-Analog	<b>Line Input Left</b>
LINER	99	I-Analog	<b>Line Input Right</b>
CDL	95	I-Analog	<b>CD Input Left</b>
CDR	100	I-Analog	<b>CD Input Right</b>
AUXL	94	I-Analog	<b>Auxiliary Input Left</b>
AUXR	1	I-Analog	<b>Auxiliary Input Right</b>
OUTL	92	O-Analog	<b>Output Left</b>
OUTR	93	O-Analog	<b>Output Right</b>
MIXOUTL	91	O-Analog	<b>Mixer Output Left</b>
MIXOUTR	89	O-Analog	<b>Mixer Output Right</b>
CINL	90	I-Analog	<b>ADC Filter Pin Left</b>
CINR	88	I-Analog	<b>ADC Filter Pin Right</b>
VREF1	2	O-Analog	<b>Analog Common:</b> Normally connected to AGND with a 0.1µF ceramic capacitor in parallel with a 10µF electrolytic capacitor.
VREF2	86	O-Analog	<b>Voltage Reference:</b> Nominal 1.85V reference available externally. Not meant for current sourcing or sinking. Normally connected to AGND with a 0.1µF ceramic capacitor in parallel with a 10µF electrolytic capacitor.

## 931-MB Mode Signal Descriptions (cont.)

## 3.2.1.5 Codec/Mixer Interface Signals

Signal Name	Pin No.	Signal/Pin Type (Drive)	Signal Description
OSCI	7	I-Analog	<b>Oscillator Input:</b> A 14.318MHz crystal oscillator is to be connected across this pin and the OSCO pin.
OSCO	8	O-Analog	<b>Oscillator Output:</b> See OSCI.

## 3.2.1.6 Power and Ground Pins

Signal Name	Pin No.	Signal/Pin Type (Drive)	Signal Description
VCC	18, 58, 67	P	<b>Power Connection</b>
GND	17, 27, 40, 57, 66	G	<b>Ground Connection</b>
AVCC	3, 6, 87	P	<b>Analog Power Connection</b>
AGND	4, 5, 85	G	<b>Analog Ground Connection</b>

# 82C931

## 3.3 931-AD Mode

Figure 3-2 931-AD Mode PQFP Pin Diagram \*

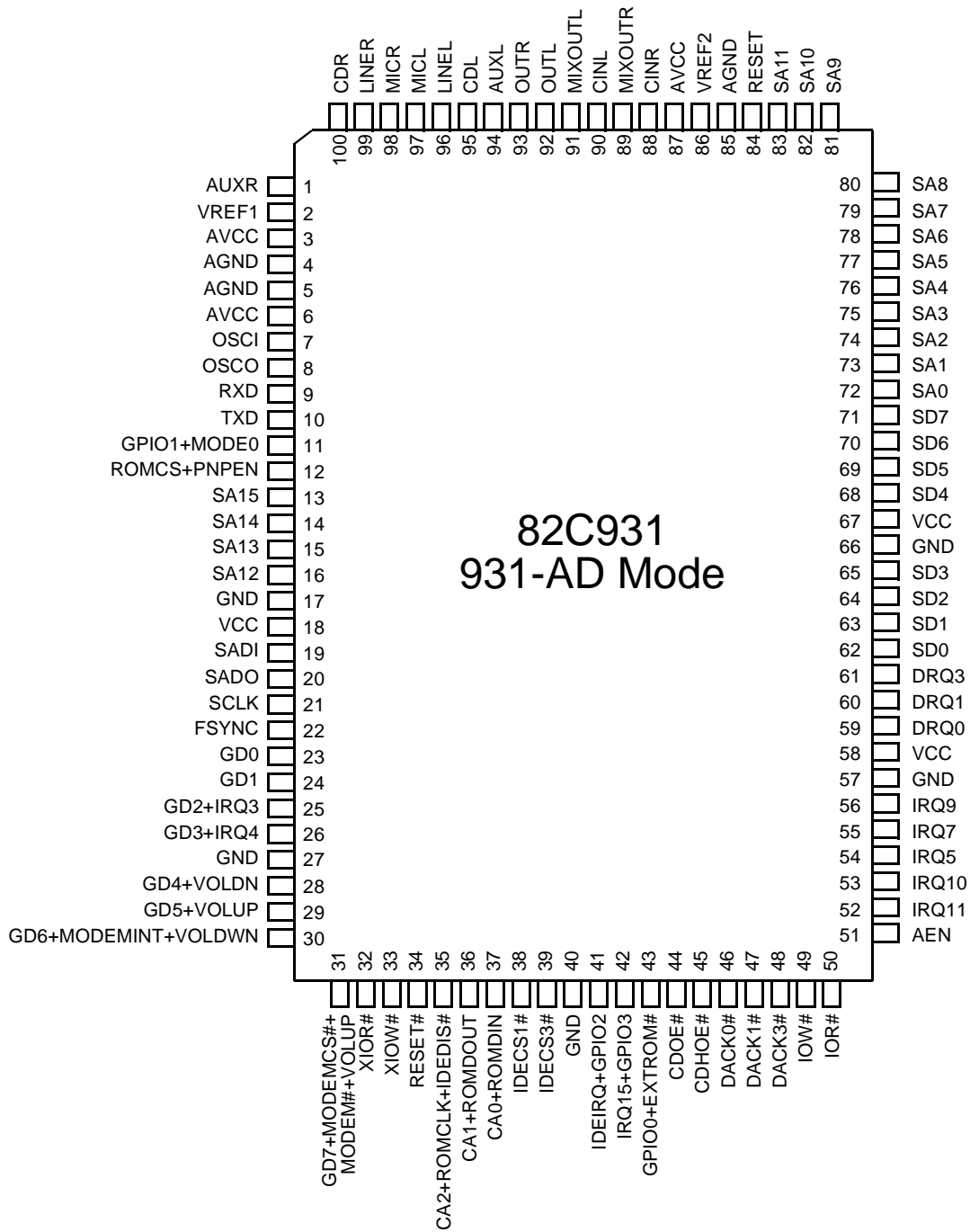

\* Pinout for TQFP Package is identical to pinout for PQFP Package.



Table 3-6 931-AD Mode Numerical Pin Cross-Reference List

Pin No.	Pin Name	Pin Type	Pin No.	Pin Name	Pin Type	Pin No.	Pin Name	Pin Type	Pin No.	Pin Name	Pin Type
1	AUXR	I	27	GND	G	50	IOR#	I	76	SA4	I/O
2	VREF1	O	28	GD4+VOLDN	I/O	51	AEN	I	77	SA5	I/O
3	AVCC	P	29	GD5+VOLUP	I/O	52	IRQ11	I/O	78	SA6	I/O
4	AGND	G	30	GD6+MODEMINT+VOLDWN	I/O	53	IRQ10	I/O	79	SA7	I/O
5	AGND	G	31	GD7+MODEMCS#+MODEM#+VOLUP	I/O	54	IRQ5	I/O	80	SA8	I/O
6	AVCC	P	32	XIOR#	O	55	IRQ7	I/O	81	SA9	I/O
7	OSCI	I	33	XIOW#	O	56	IRQ9	I/O	82	SA10	I/O
8	OSCO	O	34	RESET#	O	57	GND	G	83	SA11	I/O
9	RXD	I	35	CA2+ROMCLK+IDEDIS#	I/O	58	VCC	P	84	RESET	I
10	TXD	O	36	CA1+ROMDOUT	I/O	59	DRQ0	O-TS	85	AGND	G
11	GPIO1+MODE0	I/O	37	CA0+ROMDIN	I/O	60	DRQ1	O-TS	86	VREF2	O
12	ROMCS+PNPEN	I/O	38	IDECS1#	O	61	DRQ3	O-TS	87	AVCC	P
13	SA15	I/O	39	IDECS3#	O	62	SD0	I/O	88	CINR	I
14	SA14	I/O	40	GND	G	63	SD1	I/O	89	MIXOUTR	O
15	SA13	I/O	41	IDEIRQ+GPIO2	I/O	64	SD2	I/O	90	CINL	I
16	SA12	I/O	42	IRQ15+GPIO3	I/O	65	SD3	I/O	91	MIXOUTL	O
17	GND	G	43	GPIO0+EXTROM#	I/O	66	GND	G	92	OUTL	O
18	VCC	P	44	CDOE#	O	67	VCC	P	93	OUTR	O
19	SADI	I	45	CDHOE#	O	68	SD4	I/O	94	AUXL	I
20	SADO	O	46	DACK0#	I	69	SD5	I/O	95	CDL	I
21	SCLK	I/O	47	DACK1#	I	70	SD6	I/O	96	LINEL	I
22	FSYNC	I/O	48	DACK3#	I	71	SD7	I/O	97	MICL	I
23	GD0	I/O	49	IOW#	I	72	SA0	I/O	98	MICR	I
24	GD1	I/O				73	SA1	I/O	99	LINER	I
25	GD2+IRQ3	I/O				74	SA2	I/O	100	CDR	I
26	GD3+IRQ4	I/O				75	SA3	I/O			

Table 3-7 931-AD Mode Alphabetical Pin Cross-Reference List

Pin Name	Pin No.	Pin Type	Pin Name	Pin No.	Pin Type	Pin Name	Pin No.	Pin Type	Pin Name	Pin No.	Pin Type
AEN	51	I	GD0	23	I/O	IOR#	50	I	SA10	82	I/O
AGND	4	G	GD1	24	I/O	IOW#	49	I	SA11	83	I/O
AGND	5	G	GD2+IRQ3	25	I/O	LINEL	96	I	SA12	16	I/O
AGND	85	G	GD3+IRQ4	26	I/O	LINER	99	I	SA13	15	I/O
AUXL	94	I	GD4+VOLDN	28	I/O	MICL	97	I	SA14	14	I/O
AUXR	1	I	GD5+VOLUP	29	I/O	MICR	98	I	SA15	13	I/O
AVCC	3	P	GD6+MODEMINT+VOLDWN	30	I/O	MIXOUTL	91	O	SADI	19	I
AVCC	6	P	GD7+MODEMCS#+MODEM#+VOLUP	31	I/O	MIXOUTR	89	O	SADO	20	O
AVCC	87	P	GND	17	G	OSCI	7	I	SCLK	21	I/O
CA0+ROMDIN	37	I/O	GND	27	G	OSCO	8	O	SD0	62	I/O
CA1+ROMDOUT	36	I/O	GND	40	G	OUTL	92	O	SD1	63	I/O
CA2+ROMCLK+IDEDIS#	35	I/O	GND	57	G	OUTR	93	O	SD2	64	I/O
CDHOE#	45	O	GND	66	G	RESET	84	I	SD3	65	I/O
CDL	95	I	GPIO0+EXTROM#	43	I/O	RESET#	34	O	SD4	68	I/O
CDOE#	44	O	GPIO1+MODE0	11	I/O	ROMCS+PNPEN	12	I/O	SD5	69	I/O
CDR	100	I	IDECS1#	38	O	RXD	9	I	SD6	70	I/O
CINL	90	I	IDECS3#	39	O	SA0	72	I/O	SD7	71	I/O
CINR	88	I	IDEIRQ+GPIO2	41	I/O	SA1	73	I/O	TXD	10	O
DACK0#	46	I	IRQ5	54	I/O	SA2	74	I/O	VCC	58	P
DACK1#	47	I	IRQ7	55	I/O	SA3	75	I/O	VCC	18	P
DACK3#	48	I	IRQ9	56	I/O	SA4	76	I/O	VCC	67	P
DRQ0	59	O-TS	IRQ10	53	I/O	SA5	77	I/O	VREF1	2	O
DRQ1	60	O-TS	IRQ11	52	I/O	SA6	78	I/O	VREF2	86	O
DRQ3	61	O-TS	IRQ15+GPIO3	42	I/O	SA7	79	I/O	XIOR#	32	O
FSYNC	22	I/O				SA8	80	I/O	XIOW#	33	O
						SA9	81	I/O			

## 3.3.1 931-AD Mode Signal Descriptions

### 3.3.1.1 ISA Bus Signals

Signal Name	Pin No.	Signal/Pin Type (Drive)	Signal Description
IOW#	49	I-TTL-Smt 50KΩ PU	<i>I/O Write Command</i>
IOR#	50	I-TTL-Smt 50KΩ PU	<i>I/O Read Command</i>
AEN	51	I-TTL-Smt	<i>DMA Address Enable</i>
RESET	84	I-TTL-Smt 50KΩ PD	<i>System Reset Input</i>
SA[15:0]	13:16, 83:72	I/O-TTL (12mA)	<i>System Address Bus Lines 15 through 0</i>
SD[7:0]	71:68, 65:62	I/O-TTL (16mA)	<i>System Data Bus Lines 7 through 0</i>
DACK0# DACK1# DACK3#	46, 47, 48	I-TTL 50KΩ PU	<i>DMA Acknowledge Bits 0, 1, and 3</i>
DRQ0 DRQ1 DRQ3	59 60 61	O-TS, 50KΩ PD (12mA)	<i>DMA Request Bits 0, 1, and 3</i>
GPI00	43	I/O-TTL, PU (8mA)	<i>General Purpose I/O Bit 0</i>
EXTROM#			<i>External EEPROM Enable Jumper Input:</i> Jumper setting is latched at reset time. (If pin 43 is pulled up, external EEPROM is enabled.)
IRQ5 IRQ7 IRQ9 IRQ10 IRQ11	54 55 56 53 52	OD, I/O-TTL (12mA)	<i>Interrupt Request Bits 5, 7, and 9 through 11:</i> IRQ7 and IRQ[9:11] are bidirectional for WSS auto interrupt determination
IRQ15	42	I/O-TTL (12mA)	<i>Interrupt Request Bit 15</i>
GPI03			<i>General Purpose I/O Bit 1</i>

### 3.3.1.2 MIDI Interface Signals

Signal Name	Pin No.	Signal/Pin Type (Drive)	Signal Description
RXD	9	I-TTL-Smt	<i>Receive Data from 32KBaud MIDI UART Port</i>
TXD	10	O (20mA)	<i>Transmit Data to 32KBaud MIDI UART Port</i>

## 931-AD Mode Signal Descriptions (cont.)

## 3.3.1.3 Configuration, External PnP EEPROM, and IDE CD-ROM Interface Signals

Signal Name	Pin No.	Signal/Pin Type (Drive)	Signal Description
ROMCS	12	I/O-TTL, PU (8mA)	<b>External Serial EEPROM Chip Select</b>
PNPEN			<b>PNP Mode Enable Jumper Input:</b> Jumper setting is latched at power-on reset. This pin has an internal pull-up. Jumper pull-up: enable (default), pull-down: disable.
GPIO1	11	I/O-TTL, PU (8mA)	<b>General Purpose I/O Bit 1</b>
MODE0			<b>931 Mode Configuration Bit 0:</b> This pin is used to configure the 82C931 in either the 931-MB or 931-AD mode (refer to Table 3-1). These settings are latched into the 82C931 at reset.
CA2	35	I/O-TTL, PD (12mA)	<b>IDE CA2:</b> Buffered SA2 for CD-ROM
ROMCLK			<b>External Serial EEPROM Clock</b>
IDEDIS#			<b>IDE Disable:</b> Jumper selection to disable IDE resource. No connect equals IDE enabled. Pull down equals IDE disabled. (Available in revision 1.1 silicon only.)
CA1	36	I/O-TTL, PD (12mA)	<b>IDE CA1:</b> Buffered SA1 for CD-ROM.
ROMDOUT			<b>External Serial EEPROM Data Out</b>
CA0	37	I/O-TTL, PD (12mA)	<b>IDE CA0:</b> Buffered SA0 for CD-ROM.
ROMDIN			<b>External Serial EEPROM Data In</b>
IDECS1#	38	O-TTL (12mA)	<b>IDE CD-ROM Chip Select Bit 1:</b> CD-ROM chip select for address decode range 0170h through 0177h.
IDECS3#	39	O-TTL (12mA)	<b>IDE CD-ROM Chip Select Bit 3:</b> CD-ROM chip select for ISA address decode range 0376h through 0377h.
IDEIRQ	41	I/O-TTL (12mA)	<b>IDE CD-ROM Interrupt:</b> Interrupt input from IDE CD-ROM which redirect to IRQ5, 7, 9, 10, 11, 15 according to PNP logic.
GPIO2			<b>General Purpose I/O Bit 2</b>
RESET#	34	O (12mA)	<b>Buffered Reset</b> (active low)
CDOE#	44	O-TTL (8mA)	<b>CD Output Enable:</b> Enables low-order [7:0] of the CD data buffer.
CDHOE#	45	O-TTL (8mA)	<b>CD High Output Enable:</b> Enables high-order [15:8] of CD data buffer.
XIOR#	32	O-TTL (12mA)	<b>IDE Buffered IOR#</b>
XIOW#	33	O-TTL (12mA)	<b>IDE Buffered IOW#</b>

## 931-AD Mode Signal Descriptions (cont.)

### 3.3.1.4 Game Port and Modem Interface Signals

Signal Name	Pin No.	Signal Type (Drive)	Signal Description
GD7	31	I/O-CMOS-Smt (8mA)	<b>Game Port 2 Data Line 7</b>
MODEMCS#			<b>Modem Chip Select:</b> Output to external modem chip select pin.
MODEM#			<b>Modem Interface Enable Jumper Input:</b> Jumper setting is latched at power-on reset. Jumper pull-up: disable (default), pull-down: enable. An external pull-up is required on this pin.
VOLUP			<b>Volume Up:</b> Interface for push-button volume control. Used to increase volume.
GD6	30	I/O-CMOS-Smt (8mA)	<b>Game Port 2 Data Line 6</b>
MODEMINT			<b>Modem Interrupt:</b> Interrupt signal from external modem.
VOLDWN			<b>Volume Down:</b> Interface for push-button volume control. Used to decrease volume. An external pull-up is required on this pin.
GD5	29	I/O-CMOS (8mA)	<b>Game Port 1 Data Line 5</b> An external pull-up is required on this pin.
VOLUP			<b>Volume Up:</b> Interface for push-button volume control. Used to increase volume. VOLUP on pin 29 is only available in rev. 1.1 silicon.
GD4	28	I/O-CMOS (8mA)	<b>Game Port 1 Data Line 4</b> An external pull-up is required on this pin.
VOLDN			<b>Volume Down:</b> Interface for push-button volume control. Used to decrease volume. VOLDN on pin 28 is only available in rev. 1.1 silicon.
GD3	26	I/O-CMOS (8mA)	<b>Game Port 2 Data Line 3</b>
IRQ4			<b>Interrupt Request Bit 4</b>
GD2	25	I/O-CMOS (8mA)	<b>Game Port 2 Data Line 2</b>
IRQ3			<b>Interrupt Request Bit 3</b>
GD1	24	I/O-CMOS (8mA)	<b>Game Port 1 Data Line 1</b>
GD0	23	I/O-CMOS (8mA)	<b>Game Port 1 Data Line 0</b>

### 3.3.1.5 Codec/Mixer Interface Signals

Signal Name	Pin No.	Signal/Pin Type (Drive)	Signal Description
MICL	97	I-Analog	<b>Microphone Input Left</b>
MICR	98	I-Analog	<b>Microphone Input Right</b>
LINEL	96	I-Analog	<b>Line Input Left</b>
LINER	99	I-Analog	<b>Line Input Right</b>
CDL	95	I-Analog	<b>CD Input Left</b>
CDR	100	I-Analog	<b>CD Input Right</b>





## 931-AD Mode Signal Descriptions (cont.)

## 3.3.1.5 Codec/Mixer Interface Signals (cont.)

Signal Name	Pin No.	Signal/Pin Type (Drive)	Signal Description
AUXL	94	I-Analog	<b>Auxiliary Input Left</b>
AUXR	1	I-Analog	<b>Auxiliary Input Right</b>
OUTL	92	O-Analog	<b>Output Left</b>
OUTR	93	O-Analog	<b>Output Right</b>
MIXOUTL	91	O-Analog	<b>Mixer Output Left</b>
MIXOUTR	89	O-Analog	<b>Mixer Output Right</b>
CINL	90	I-Analog	<b>ADC Filter Pin Left</b>
CINR	88	I-Analog	<b>ADC Filter Pin Right</b>
VREF1	2	O-Analog	<b>Analog Common:</b> Normally connected to AGND with a 0.1 $\mu$ F ceramic capacitor in parallel with a 10 $\mu$ F electrolytic capacitor.
VREF2	86	O-Analog	<b>Voltage Reference:</b> Nominal 1.85V reference available externally. Not meant for current sourcing or sinking. Normally connected to AVS with a 0.1 $\mu$ F ceramic capacitor in parallel with a 10 $\mu$ F electrolytic capacitor.
OSCI	7	I-Analog	<b>Oscillator Input:</b> A 14.318MHz crystal oscillator is to be connected across this pin and the OSCO pin.
OSCO	8	O-Analog	<b>Oscillator Output:</b> See OSCI.

## 3.3.1.6 Serial Audio Interface Signals

Signal Name	Pin No.	Signal/Pin Type (Drive)	Signal Description
SADI	19	I-TTL	<b>Serial Audio Data Input</b>
SADO	20	O-TTL	<b>Serial Audio Data Output</b>
SCLK	21	I/O-TTL	<b>Serial Audio Clock</b>
FSYNC	22	I/O-TTL	<b>Serial Audio Synchronization</b>

## 3.3.1.7 Power and Ground Pins

Signal Name	Pin No.	Signal/Pin Type (Drive)	Signal Description
VCC	18, 58, 67	P	<b>Power Connection</b>
GND	17, 27, 40, 57, 66	G	<b>Ground Connection</b>
AVCC	3, 6, 87	P	<b>Analog Power Connection</b>
AGND	4, 5, 85	G	<b>Analog Ground Connection</b>



## 4.0 Functional Description

The 82C931 is an optimized single chip solution with built-in Plug-and-Play functions, built-in FM synthesizer and 16-bit Sigma-Delta Codec to provide all of the features needed to create the following sound characteristics and applications:

- 16-bit sound quality Sound Blaster Pro and Windows Sound System compatible card
- 22 voice FM synthesis
- 16-bit CD-quality digital wave audio up to 44.1KHz stereo
- Game port
- MPU-401 MIDI interface
- Wavetable synthesis upgrade

The following sub-sections will discuss these built-in functions in detail.

### 4.1 Plug and Play

The OPTi 82C931 supports the ISA Plug and Play (PnP) Specification 1.0a. After power-up, the 82C931 is isolated from other PnP cards in the host system by the system software. With this mechanism, the I/O address, IRQ and DMA usage of the 82C931 can be configured by the system according to the free resources available. As a result, the chance of getting a resource conflict is minimized.

The PnP function is disabled by pulling pin 12 (PNPEN) of the 82C931 low at power-up; otherwise the 82C931 will operate in PnP mode.

A PnP configuration sequence is carried out by either the system BIOS supporting PnP or Configuration Manager software of the operating system. It is used to map the various functional blocks (logical devices) within the 82C931 into the host system address space as well as to configure the DMA and IRQ channels. The configuration sequence occurs as follows:

1. The 82C931 is isolated from the system.
2. A unique identifier (handle) is programmed into the 82C931 and the resource data is read.
3. After the resource requirement and capabilities are determined, the handle is used to assign conflict-free resources by programming the appropriate information into the 82C931 configuration registers a logical device at a time
4. After the configuration registers are programmed, the 82C931 leaves the configuration mode and each logical device is activated individually. The bus interface of each logical device is then enabled.

The 82C931 supports the following logical devices:

- IDE CD-ROM interface
- Windows Sound System
- FM synthesis
- Sound Blaster Pro
- Game Port
- MPU-401 MIDI interface
- Modem interface
- 82C931 Master Control

## 4.2 16-Bit Codec/Mixer

### 4.2.1 Codec

Features of the built-in 16-bit stereo sigma-delta codec include:

- Sigma-delta stereo ADC with 128X over-sampling
- Sigma-delta stereo DAC with 128X over-sampling
- On-chip 8X Interpolation Filter
- On-chip analog post filter
- Single-ended input and output
- Sampling rate of 5KHz to 48KHz

The codec serial interface provides a means to read and write 16-bit stereo data from the ADC or to the DAC respectively. The interface (as shown in Figure 4-1) consists of the following lines:

- DAC[15:0] - to write to the DAC 16-bit input
- ADC[15:0] - to read the ADC 16-bit output

- L/R - to select between the left and right channels for both the ADC and DAC data.
- MCLK - This internal master clock signal is synthesized by the frequency synthesizer from the crystal reference of 14.318MHz. One of 236 frequencies may be selected through the 8-bit FSEL line. MCLK is not active when the frequency synthesizer is powered down. The frequency of MCLK is 256 times the sampling frequency.

The DAC left/right 16-bit input data are multiplexed onto DAC[15:0] and fed into the codec. The L/R signal qualifies the data. The period of L/R is equal to that of the codec sampling frequency. One set of left/right 16-bit input data to the DAC is sent every L/R cycle. When L/R is low, the data on DAC[15:0] is meant for the left channel; when L/R is high, the data is meant for the right channel. This means that the DAC treats data packets L1 and R1 as belonging to the same sampling instance; while L2 and R2 are data for the next sampling instance.

The ADC left/right 16-bit output data are similarly multiplexed onto the ADC[15:0] bus.

**Figure 4-1 Functional Block Diagram**

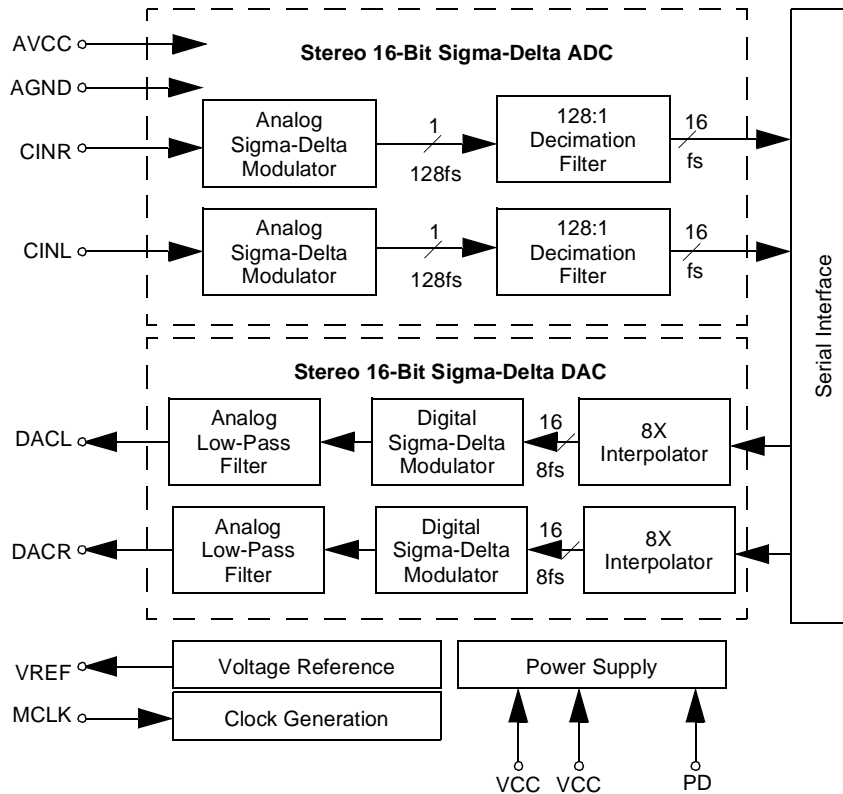

#### 4.2.2 Mixer

The built-in mixer mixes two mono microphone level inputs (MICL/R) and five stereo analog line level input sources (LINEL/R, CDL/R, AUXL/R, FML/R, and DACL/R) with individual mixer programmable gain and mute control. The DACL/R stereo analog inputs are routed to a programmable circuit with 1.5dB steps (total of 32 levels). Internal amplifiers with a programmable 20dB gain block are provided for the MIC input (only). The remaining stereo analog inputs are routed to a programmable gain circuit which can be programmed in 3dB steps (total of 16 levels). Also, internal amplifiers with a programmable 20dB gain block are provided. Level changes only take effect on zero crossings to minimize audible artifacts. AC coupling is mandatory for

these inputs since any DC offset on the input will be amplified.

MIXOUTL (mixer record output left) must be connected to CINL (codec analog input left) with a ceramic capacitor. MIXOUTR (mixer record output right) must be connected to CINR (codec analog input right) with a ceramic capacitor. MIXOUT/R are routed via gain control (1.5dB steps: total of 16 levels). Analog output OUTL/R are routed via a master volume control which provides 0db to 94.5db of attenuation, adjustable in 3dB steps. The Codec Indirect Registers used for programming the various functions/gain levels for the mixer. For details regarding these registers, refer to Table 5-10 and Table 5-11 in the Register Section. Figure 4-2 shows a functional block diagram of the mixer.

Figure 4-2 Mixer Block Diagram

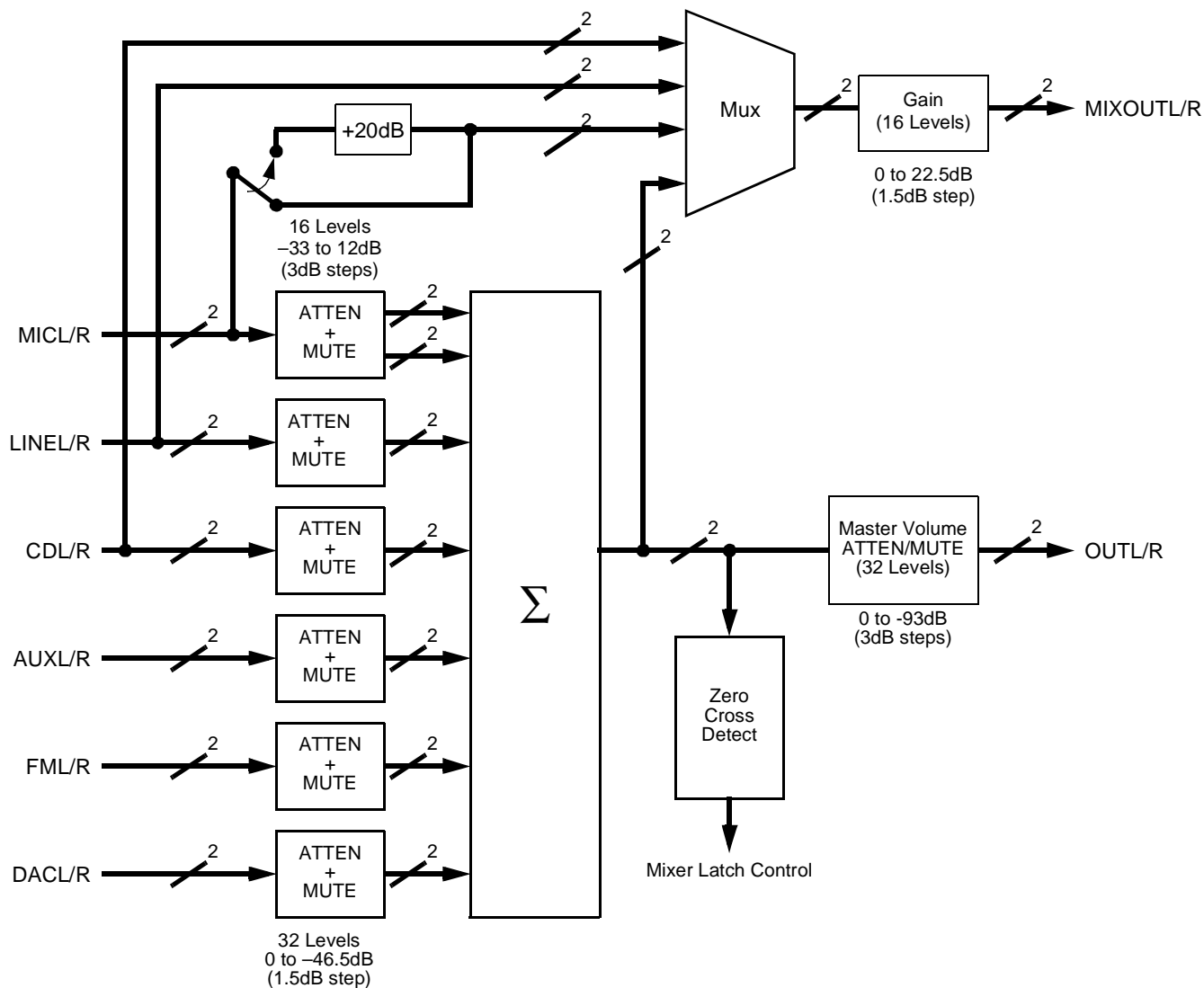

## 4.3 Frequency Synthesizer

The Frequency Synthesizer (FS) block generates the codec sampling clock from a reference crystal oscillator of 14.318MHz. The output frequency of the FA is equal to 256 times fs (where fs = codec sampling frequency).

One of the 236 frequencies may be generated by the FS. The selection of the FS output frequency is done via programming eight register bits in the Digital Audio Processor Write Command/Data (40h/FSEL[7:0]).

Table 4-1 gives the Frequency Selection, where the FSEL[7:0] address is given in decimal equivalent. FOUT-actual is the FS output frequency for a given FSEL code and %error gives the difference between the FOUT-actual and the target FOUT-spec.

Shaded table entries refer to the 14 critical sampling frequencies. The error for these frequencies fall within  $\pm 0.15\%$ .

**Table 4-1 FS Output Frequencies**

FSEL	FOUT-actual (Hz)	FSEL	FOUT-actual (Hz)	FSEL	FOUT-actual (Hz)	FSEL	FOUT-actual (Hz)	FSEL	FOUT-actual (Hz)
0	3909.064	43	4713.176	86	5887.335	129	7877.421	172	11910.952
1	3924.890	44	4716.962	87	5915.640	130	7935.969	173	12046.394
2	3938.710	45	4739.804	88	5949.967	131	7989.955	174	12189.804
3	3947.978	46	4759.973	89	5992.466	132	8066.782	175	12356.559
4	3951.554	47	4783.460	90	6023.197	133	8129.315	176	12494.931
5	3957.289	48	4806.457	91	6059.049	134	8196.592	177	12663.325
6	3994.978	49	4833.430	92	6101.420	135	8262.340	178	12817.220
7	4030.968	50	4847.240	93	6138.624	136	8329.953	179	12983.677
8	4033.391	51	4877.589	94	6168.715	137	8389.453	180	13159.926
9	4047.543	52	4906.113	95	6214.410	138	8474.195	181	13332.077
10	4067.614	53	4934.972	96	6260.786	139	8544.813	182	13511.104
11	4084.752	54	4955.795	97	6292.090	140	8636.202	183	13697.066
12	4092.416	55	4971.528	98	6331.663	141	8691.776	184	13866.865
13	4112.477	56	4993.722	99	6377.947	142	8773.284	185	14099.921
14	4131.170	57	5019.331	100	6408.610	143	8849.634	186	14286.387
15	4142.940	58	5049.208	101	6453.425	144	8924.950	187	14487.810
16	4164.977	59	5084.517	102	6491.839	145	9005.628	188	14703.165
17	4178.655	60	5115.520	103	6544.963	146	9088.574	189	14914.583
18	4209.761	61	5126.888	104	6579.963	147	9175.964	190	15147.624
19	4221.108	62	5151.419	105	6615.339	148	9219.179	191	15380.664
20	4237.097	63	5178.675	106	6670.513	149	9321.614	192	15627.413
21	4255.520	64	5202.762	107	6711.562	150	9433.923	193	15871.938
22	4276.976	65	5243.408	108	6750.135	151	9519.947	194	16018.697
23	4302.284	66	5268.739	109	6802.259	152	9599.872	195	16379.408
24	4302.284	67	5290.646	110	6848.533	153	9710.015	196	16665.917
25	4327.892	68	5326.637	111	6895.441	154	9805.854	197	16948.390
26	4350.087	69	5346.220	112	6935.281	155	9904.215	198	17244.987
27	4369.507	70	5377.855	113	6991.211	156	10025.133	199	17537.275
28	4386.642	71	5412.550	114	7049.961	157	10098.416	200	17839.642
29	4415.502	72	5437.608	115	7089.679	158	10209.387	201	18177.148
30	4433.451	73	5456.555	116	7139.960	159	10302.837	202	18511.939
31	4448.952	74	5493.094	117	7190.960	160	10418.275	203	18905.810
32	4462.475	75	5514.194	118	7250.145	161	10532.214	204	19225.830
33	4488.185	76	5519.377	119	7295.177	162	10634.518	205	19617.129
34	4500.090	77	5523.920	120	7359.169	163	10755.709	206	20034.515
35	4523.725	78	5592.969	121	7402.459	164	10875.217	207	20418.775
36	4544.287	79	5668.549	122	7457.292	165	10986.188	208	20836.550
37	4565.689	80	5680.359	123	7512.943	166	11028.389	209	21286.672
38	4584.401	81	5720.082	124	7573.812	167	11263.617	210	21750.434
39	4601.810	82	5746.201	125	7626.775	168	11360.718	211	22049.203
40	4605.974	83	5785.830	126	7690.332	169	11485.561	212	22721.435
41	4609.590	84	5804.024	127	7752.630	170	11616.166	213	23238.391
42	4660.807	85	5843.400	128	7813.706	171	11774.671	214	23821.904
								215	24394.863
								216	24989.860
								217	25634.440
								218	26303.566
								219	27446.976
								220	27703.490
								221	28566.238
								222	29417.563
								223	30295.247
								224	31254.825
								225	32007.953
								226	33080.364
								227	34502.080
								228	35691.971
								229	37053.418
								230	38003.505
								231	40005.262
								232	41693.039
								233	44098.407
								234	45495.044
								235	48006.315



#### 4.4 16-Bit Type F DMA Playback

The 82C931 supports the Type F DMA playback.

#### 4.5 Modem Interface

The 82C931 includes the modem as a PnP logical device, as well as interface pins to connect to a modem chipset. When PnP is activated (931-AD Mode), the 82C931 provides the resource configuration for the modem chipset, such as the I/O address range and interrupt level.

The modem interface pins include pin 31 (MODEMCS#), pin 30 (MODEMINT), pin 25 (IRQ3), and pin 26 (IRQ4). To use the modem interface, pin 31 (MODEM#) must be pulled low. If a modem is connected with the 82C931, the joystick port will provide support for one joystick only.

#### 4.6 Push Button Volume Control

In silicon revision 1.0, two pins of the joystick interface can be used as volume control push-buttons (pin 30 as volume down, and pin 31 as volume up) so that the speaker volume can be controlled through front panel buttons in desktop or notebook PCs. Appropriate software drivers are needed to enable this feature.

When the volume control feature is enabled, only one joystick will be supported by the joystick port.

In silicon revision 1.1, the volume pins are additionally available in pins 28 and 29, as shown:

pin#31 & 29	Volume up
pin#30 & 28	Volume down

These two pins are active-low, edge-triggering and pulled up internally. When the button is pressed and the corresponding pin is activated, the register bits MCIR16[5:4] are set accordingly. The software drivers poll these two bits periodically. The scheme is as follows:

Buttons	MCIR[5:4] (BUTUP: BUTDN)	Action required for the driver
Press UP button	10	increase the volume by one step
Press Down button	01	decrease the volume by one step
Press both Up & Down button	11	mute

The register bits MCIR[5:4] will be cleared automatically after they are read by the driver.

#### 4.7 External Serial EEPROM

The 82C931 has the resource data and serial identifier required by the PnP specification stored internally. If an OEM

customer wants to use a different resource data and serial identifier to customize their application, an external EEPROM can be used. To use an external EEPROM, pin 43 (EXTROM#) must be pulled low. This enables the resource data and serial identifier to be read from the external EEPROM instead of the 82C931's internal storage.

The 82C931 provides a serial EEPROM interface that is compatible with devices from a number of vendors. A 512-byte EEPROM is sufficient for information required by PnP. Pin 35 of the 82C931 provides the data clock for the EEPROM. Pin 36 provides data to the EEPROM, while pin 37 gets input from the EEPROM.

#### 4.8 Serial Audio Interface

When the 82C931 is implemented in MB mode, the SAIO connector is coming from pins 25, 26, 30 and 31.

	931-MB mode (no pull-down at pin#11)	931-AD mode (pull-down at pin#11)
SCLK	pin#26	pin#21
FSYNC (LRCLK)	pin#25	pin#22
SADI	pin#31	pin#19
SADO	pin#30	pin#20

The 82C931's serial audio interface supports the following formats:

- I<sup>2</sup>S-justified format (ZV port) and its variations.
- Sony format (short right-justified format, used by OPT's wavetable chip and the Philips TDA1311AT DAC).
- AT&T PCM codec T7525 compatible 16-bit mono format.

Please refer to sections 4.8.6, *ZV-Port I2S*, 4.8.7, *Advanced Precision General Purpose Serial Port*, 4.8.8, *TDA1311 Stereo Continuous Calibration*, for the respective timing diagrams.

##### 4.8.1 I<sup>2</sup>S-justified format and its variations

In the I<sup>2</sup>S-justified format (ZV-port), LRCLK is low for the left channel, and high for the right channel. The left-channel MSB is left-justified to the high-to-low LRCLK transition with a single SCLK delay. SDATA could be SADI when the 931 is in receive mode, and SADO when the 931 is in transmit mode. The LRCLK period is programmable with a minimum of 32 SCLKs (MC22[4]). The following example assumes LRCLK period is greater than 32 SCLKs. Please note that in ZV port, there is one more signal MCLK defined but this is not needed for the 931.

To program the 931 in the I<sup>2</sup>S-justified mode, the MC22 and MC21 registers need to be set. The relevant MC22 and MC21 bit definitions are shown below for reference.

I<sup>2</sup>S-justified mode (ZV-port):

MC22[7:0] = "00110001" (31H).

MC21[7:0] = "10000010" (82H).

There are other I<sup>2</sup>S variations: left-justified and right-justified.

For the left-justified, LRCLK is high for the left channel, and low for the right channel. The MSB is left-justified to an LRCLK transition, with zero SCLK delay.

MC22[7:0] = "00110100" (34H).

MC21[7:0] = "10000010" (82H).

For the right-justified, LRCLK is high for the left channel, and low for the right channel. The MSB is delayed from an LRCLK transition, the LSB will be right-justified to the next LRCLK transition.

MC22[7:0] = "00010100" (14H).

MC21[7:0] = "10000010" (82H).

#### 4.8.2 Sony format<sup>1</sup>

This data format is essentially the same as the I<sup>2</sup>S right-justified format. Normally there are only 32 SCLKs in a LRCLK period. The LRCLK is high for the left channel, and low for the right channel. The MSB comes in first. To set up the 931 in Sony format:

MC22[7:0] = "00000100" (04H).

MC21[7:0] = "10000010" (82H).

#### 4.8.3 AT&T PCM codec T7525 compatible 16-bit mono format

The 931 supports the T7525 receive timing - word format with positive FSYNC. The benefit is that the 931's secondary DAC

could be used to save a T7525 as the voice codec in modem/audio combo solution. To program the 931 in T7525 mode:

MC22[7:0] = "00110010" (32H)

MC21[7:0] = "10000010" (82H)

In short summary:

	I <sup>2</sup> S-justified	left-justified	right-justified	Sony format	T7525 format
MC22[7:0]	31H*	34H*	14H*	04H*	32H
MC21[7:0]	82H				

\* The MC22[4] bit setting may vary, depending on the LRCLK period (32 SCLK or more).

#### 4.8.4 Testing I<sup>2</sup>S format (ZV port) with Audio Precision machine

The Audio Precision machine system two 2322 has a serial audio data port that can generate a test tone in the I<sup>2</sup>S format with programmable FSYNC, ranging from 24KHz to 48KHz. The 931 was tested with AP machine in various test tones: 256Hz, 1KHz and 3KHz in both sine wave and square wave with FSYNC = 48KHz.

To test out the feature, the AP machine is hooked up with the 931 with appropriate connections (AP's pin#6, 12, 14 are SDATA, SCLK and FSYNC, respectively). The next step is to setup the MC22 to "31H" and MC21 to "82H". Then the test tone could be heard from the speaker connected to the 931. Please note that there might be some noise in the speaker. This is due to unshielded cable used to connect the serial audio interface. Shielding the cable would help improve the audio quality.

#### 4.8.5 Relevant MC register settings

MC22 Serial Audio format control register (R/W)							Default: 00h
bit 7	bit 6	bit 5	bit 4	bit 3	bit 2	bit 1	bit 0
Reset ASIO	ASIO test enable	First16-bit	CLK32	SCLK Polarity	FSYNC Polarity	Pulse Mode	I <sup>2</sup> S Mode

Bit 5 First16-bit: Specifies where the data is located in the LRCLK period

0: data located at the last 16 bits of the left/right channel in an LRCLK period

1: data located at the first 16 (or 17) bit of the left/right channel in an LRCLK period

Bit 4 CLK32: Specifies the number of SCLKs per LRCLK period, used only in delay-mode or pulse-mode ASIO

0: 32 SCLK per LRCLK period

1: more than 32 SCLK per LRCLK period

1. Short right-justified format, used by OPTi's wavetable chip and the Philips TDA1311AT DAC.



- Bit 3 SCLK polarity:  
 0: SDATA and LRCLK change at the rising edge of SCLK  
 1: SDATA and LRCLK change at the falling edge of SCLK
- Bit 2 FSYNC (LRCLK) polarity:  
 0: LRCLK is LOW for the left channel, HIGH for the right channel  
 1: LRCLK is HIGH for the left channel, LOW for the right channel
- Bit 1 Pulse mode: Used for AT&T T7525 codec or CS8412 DSP data format  
 0: Pulse mode disabled  
 1: Pulse mode enabled, used for AT&T T7525 or CS8412 data format
- Bit 0 I<sup>2</sup>S mode: MSB delay mode  
 0: Zero SCLK delay from an LRCLK transition to MSB data  
 1: One SCLK delay from an LRCLK transition to MSB data

MC21 Serial Audio selection control register (R/W)							Default: 00h
bit 7	bit 6	bit 5	bit 4	bit 3	bit 2	bit 1	bit 0
CTL_SEL[1:0]		P2S_SEL[1:0]		SPCDSEL	ADCSEL	FDACSEL	DACSEL

bit [7:6] CTL\_SEL[1:0]: ASIO shift clock selection  
 00/11: Use the shift clock from internal FS  
 01: Use FM timing  
 10: Use external SCLK

bit 1 FDACSEL: selects the data source to the FDAC  
 0: FDAC takes FM data  
 1: FDAC takes SADI (if SPCDSEL=0) or second DMA playback data (if SPCDSEL=1)

## 4.8.6 ZV-Port I<sup>2</sup>S

### 4.8.6.1 LRCLK

This signal determines which audio channel (left/right) is currently being input on the audio Serial Data input line. LRCLK is low to indicate the left channel and high to indicate the right channel. Typical frequency values for this signal are 48KHz, 44.1KHz, 32KHz, and 22KHz.

### 4.8.6.2 SDATA

This signal is the digital PCM signal that carries the audio information. Digital audio data is transferred using the I<sup>2</sup>S format.

### I<sup>2</sup>S Format

The I<sup>2</sup>S format is shown below. The digital audio data is left channel-MSB justified to the high-to-low going edge of the LRCLK plus one SCLK delay.

Figure 4-3 I<sup>2</sup>S Format

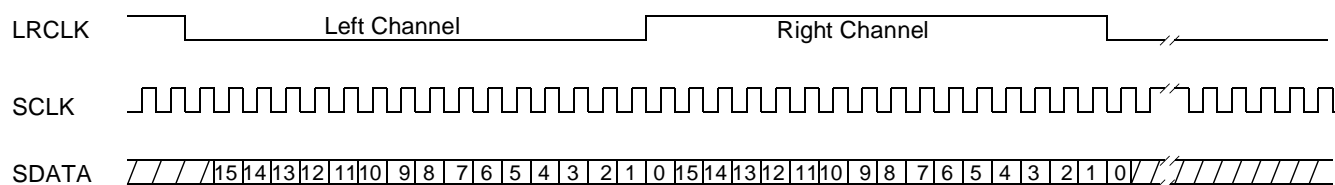

### 4.8.6.3 SCLK

This signal is the serial digital audio PCM clock.

### 4.8.6.4 MCLK

This signal is the Master clock for the digital audio. MCLK is asynchronous to LRCLK, SDATA and SCLK.

The MCLK must be either 256x or 384x the desired Input Word Rate (IWR). IWR is the frequency at which words for each channel are input to the DAC and is equal to the LRCLK frequency. The following table illustrates several standard audio word rates and the required MCLK and LRCLK frequencies. Typically, most devices operate with 384fx master clock.

The ZV Port audio DAC should support an MCLK frequency of 384fs. This results in the frequencies shown below.

LRCLK (KHz) Sample Frequency	SCLK (MHz) 32xfs	MCLK (MHz) 384x
22	0.704	8.448
32	1.0240	12.2880
44.1	1.4112	16.9344
48	1.5360	18.4320

### 4.8.7 Advanced Precision General Purpose Serial Port

The 15-pin "D-sub" connector on the rear panel provides all input and output signals for a general purpose serial input/output port, plus DSP-program specific input and output pins which may be used in certain DSP (.AZ2) programs. The pinout of the connector is detailed below. All inputs are TTL level compatible CMOS. All outputs are CMOS isolated by 50Ω series resistors and rise time limiting networks.

Pin	Function	Pin	Function
1	Ground	9	Serial Input Master Clock (input)
2	+5V (tied to unused inputs high)	10	Serial Input Bit Clock (input)
3	Auxiliary Input (DSP program specific)	11	Auxiliary Output (DSP program specific)
4	Ground	12	Serial Output Bit Clock (output)
5	Ground	13	Serial Input Data (input)
6	Serial Output Data (output)	14	Serial Output Frame Sync (output)
7	Ground	15	Serial Input Frame Sync (input)
8	Ground		

Figure 4-4 General Purpose Serial Port, Timing Relationships

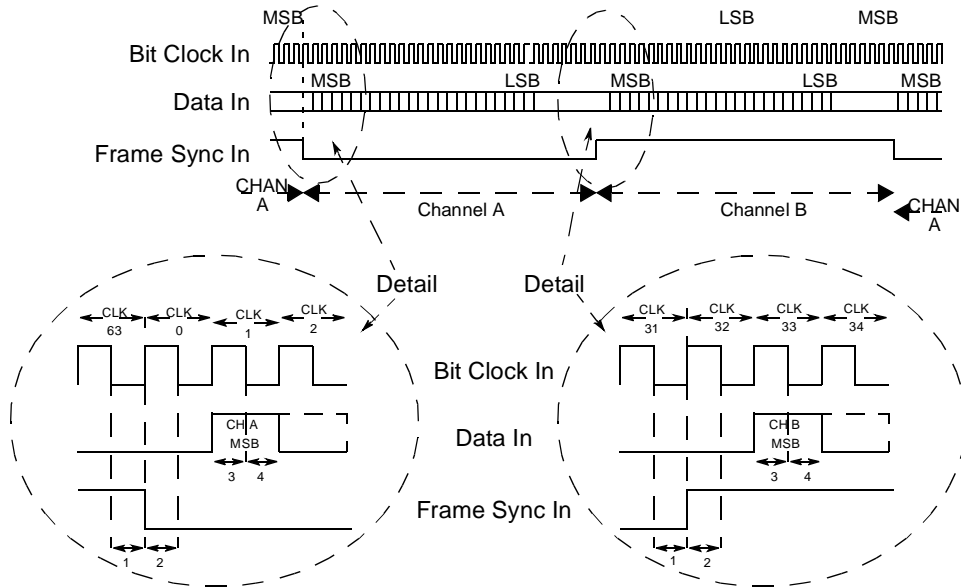

1. FRAME SYNC INPUT SETUP TIME (from falling edge, las bit clock previous subframe) 30nS minimum
2. FRAME SYNC INPUT SETUP TIME (to falling edge, first bit clock of present subframe) 30nS minimum
3. DATA INPUT SETUP TIME (to bit clock falling edge) 30nS minimum
4. DATA INPUT HOLD TIME (from bit clock falling edge) 45nS minimum

## 4.8.8 TDA1311 Stereo Continuous Calibration

Figure 4-5 Format of Input Signals

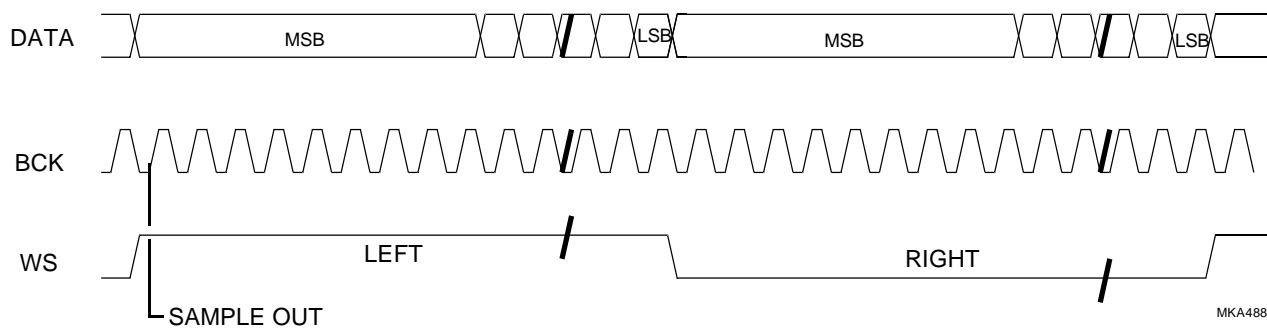



## 5.0 Register Descriptions

### 5.1 I/O Base Addresses

Table 5-1 lists the I/O base address registers of the 82C931. These base addresses are programmable, which assists in avoiding possible I/O port conflicts among different devices.

The configuration registers, called MC Indirect Registers, located via MCBBase control most functions of the 82C931. An indirect addressing scheme is used to access the MC Indirect Registers.

The MC address (0E0Eh-0EFEh) and data (0E0Fh-0FFFh) I/O port addresses are fully programmable. The only fixed I/O port used by the 82C931 is at 0F8Dh.

The remaining I/O base address registers are accessed by the same type of indexing scheme as MCBBase (CPU Direct I/O R/W).

Table 5-2 gives the register map of the 82C931.

### 5.2 MCBBase Register

MCBBase is the Direct MC base address register which controls access to the MC Indirect Registers (MCIR1-23). MCIR1-23 control most of the basic functions of the 82C931 (i.e., CD-ROM select, base decode address select, etc.).

To avoid possible conflict of I/O ports with different devices, the 82C931 uses a unique indirect addressing scheme with the base addresses being programmable. Under this design scheme, the only fixed I/O port used by 82C931 is at 0F8Dh. The MC address and data I/O port addresses are fully programmable, from 0E0Eh-0EFEh (address port) and 0E0Fh-0FFFh (data port). To access the MC registers:

- (1) All MC registers in 82C931 are password protected. To read or write into the MC registers, the password E4h must be written into I/O Port 0F8Dh before accessing the address or data port.
- (2) The address and data access port address can be fully programmable by writing the desired base address selection into I/O port 0F8Dh bit 4 to bit 0, [b4..b0]. The port address can be read as '111b4, b3..b0, 1110' for the address port and '111b4, b3..b0, 1111' for the data port. Therefore, the possible address and data access ports can be any one from 0E0Eh-0FFEh (address port) and 0E0Fh-0FFFh (data port).

**Table 5-1 82C931 I/O Base Addresses**

Base Register	Function	Address Selections
MCBBase	Configuration	0F8D; 0E0[E..F] to 0FF[E..F]
SBBBase	Digital Audio Processor	220/240
WSBase	Windows Sound System	530/640/E80/F40
IDEBase	IDE CD ROM	170/370
ALBase	AdLib	388
OPL4Base	OPL4	380
MIDIBase	MPU-401	300/310/320/330

**Table 5-2 82C931 Register Map**

I/O Address	Register Name (Type)
SBBBase+00h (or ALBase+00h)	Left FM Status Port (RO)
SBBBase+00h (or ALBase+00h)	Left FM Register Address Port (WO)
SBBBase+01h (or ALBase+01h)	Left FM Data Port (WO)
SBBBase+02h (or ALBase+02h)	Right FM Register Address Port (WO)
SBBBase+03h (or ALBase+03h)	Right FM Data Port (WO)
SBBBase+04h	Mixer Address Port (WO)
SBBBase+05h	Mixer Data Port (R/W)
SBBBase+06h	DAP Reset (WO)
SBBBase+08h	FM Status Port (RO)
SBBBase+08h	FM Register Address Port (WO)
SBBBase+09h	FM Data Port (WO)
SBBBase+0Ah	DAP Read Data (RO)
SBBBase+0Ch	DAP Write Data/Cmd (WO)
SBBBase+0Ch	DAP Write Buffer Status (RO)
SBBBase+0Eh	DAP Output Buffer Status (RO)
WSBase+00h-03h	Configuration (WO)
WSBase+00h-03h	Version (RO)
WSBase+04h	Codec Index Reg (R/W, exists in Codec and shadowed in 82C931)
WSBase+05h	Codec Indexed Data Reg (R/W, exists in Codec only)
WSBase+06h	Codec Status Reg (R/W, exists in Codec only)
WSBase+07h	Codec Direct Data (R/W, exists in Codec only)
200h-201h	Game Port (R/W)
0F8Dh	MCBBase/Password Register - Specifies: MC Index Port Address (R/W) MC Data Port Address (R/W)
380-383/388-38B	OPL4 (R/W)
388-38F	OPL5 (R/W)

(3) To access MCIR1-23, write the corresponding register index into the address access port and read (or write) the data from (or to) the data access port. This read or write is only possible if the correct password (E4h) has been written into Port 0F8Dh, or is disabled (0F8Dh[7] = 1).

Tables 5-3 through 5-5 illustrate the necessary steps to access MCIR1-23. Table 5-6 gives the bit formats for the MCIR1-23.

**Table 5-3 MCBASE, Direct MC Register**

7	6	5	4	3	2	1	0
<b>Port 0F8Dh MCBASE Register (WO)</b>							
Pass word protection for access to address or data port: 0 = Enable 1 = Disable	Reserved		These bits specify the address for MCIdx[8:4] and MCDData[8:4]: (Refer to Table 5-4.) Address range = 00000 through 11111				

**Table 5-4 McBASE, Index (MCIdx) and Data (MCDData) Ports Address Range**

15	14	13	12	11	10	9	8	7	6	5	4	3	2	1	0
<b>Index Port Address [15:0]</b>															
0	0	0	0	1	1	1	Specified by MCBASE[4:0] (Refer to Table 5-3)					1	1	1	0
<b>Data Port Address [15:0]</b>															
0	0	0	0	1	1	1	Specified by MCBASE[4:0] (Refer to Table 5-3)					1	1	1	1

**Table 5-5 MCIdx and MCDData Registers**

7	6	5	4	3	2	1	0
<b>MCIdx</b>							
0	0	0	Specifies which MCIR register is to be accessed.				
			00000 = Disable	01101 = MCIR13: PNP Status			
			00001 = MCIR1: Base/Type Configuration	01110 = MCIR14: PNP CSN			
			00010 = MCIR2: Reserved	01111 = MCIR15: PNP READ_DATA			
			00011 = MCIR3: SB/WSS Configuration	10000 = MCIR16: Volume Control			
			00100 = MCIR4: User Programmable GP	10001 = MCIR17: Serial EEPROM			
			00101 = MCIR5: Option	10010 = MCIR18: CONFIG Status			
			00110 = MCIR6: MIDI Interface	10011 = MCIR19: FM Control			
			00111 = MCIR7: Semaphore Software	10100 = MCIR20: GPIO Control			
			01000 = MCIR8: Reserved	10101 = MCIR21: Serial Audio Control			
			01001 = MCIR9: Test Control	10110 = MCIR22: Serial Audio Control			
			01010 = MCIR10: Test Control	10111 = MCIR23: Reserved			
			01011 = MCIR11: Status	Remaining combinations = Reserved			
			01100 = MCIR12: Test				
<b>MCDData (refer to Table 5-6)</b>							



Table 5-6 MC Indirect Registers

7	6	5	4	3	2	1	0	
<b>MCIR1 Base/Type Configuration Register</b>								<b>Default = 06h</b>
Sound Blaster I/O base address (SBBase): 0 = 220 1 = 240	Reserved	Windows Sound System I/O base address (WSBase): 00 = 530    10 = F40 01 = E80    11 = 640		CD-ROM interface: The sense of these bits is reversed during writes. To disable CD, write b'011'. 000 = Disabled 100 = Secondary IDE All others = Reserved		Game port: 0 = Disable 1 = Enable		
<b>MCIR2 BAUD 96 register</b>								<b>Default = 00h</b>
Reserved Set to 0.			BAUD96: This bit could be used by PDA devices to communicate with other devices 0 = Disabled, normal MIDI UART in RXD pin. 1 = Enabled, 9600 baud rate UART in RXD pin		Reserved Set to 0.			
<b>MCIR3 Sound Blaster/Windows Sound System Configuration Register</b>								<b>Default = 00h</b>
Reserved: Must be set to 0.	Reserved: Must be set to 0 for normal operation in WSS.	DAP IRQ select: 000 = Disable    100 = IRQ11 001 = IRQ7        101 = IRQ5 010 = IRQ9        110 = Reserved 011 = IRQ10       111 = Reserved		DAP DMA select: 000 = Disabled    100 = Disable    DRQ1 <sup>(1)</sup> 001 = DRQ0        101 = DRQ0       DRQ1 <sup>(1)</sup> 010 = DRQ1        110 = DRQ1       DRQ0 <sup>(1)</sup> 011 = DRQ3        111 = DRQ3       DRQ0 <sup>(1)</sup>				
(1) If CIR9[2] = 0 (Codec Indirect Register 9, bit 2), then DAP DMA[4:7] can be selected								
<b>MCIR4 User Programmable General Purpose Register</b>								<b>Default = 10h</b>
Playback FIFO flow control: 00 = Empty    10 = Full-4 01 = Full-2    11 = Not full		OPL select: 00 = OPL2    10 = OPL4 01 = OPL3    11 = OPL5		Digital-Analog controller zero: 0 = Hold 1 = Clear	Audio: <sup>(1)</sup> 0 = Disable 1 = Enable	Sound Blaster version: 00 = 2.1    10 = 3.2 01 = 1.5    11 = 4.4		
(1) Bit 2 can also accessed through the MC register or through PNP logic.								
<b>MCIR5 Option Register</b>								<b>Default = 00h</b>
Reserved		Codec Expanded Mode: <sup>(1)</sup> 0 = Disable 1 = Enable	Sound Blaster ADPCM: 0 = Disable 1 = Enable	Command FIFO in Sound Blaster mode: 0 = Disable 1 = Enable	Volume effect for Sound Blaster Pro mixer voice volume emulation: 0 = Disable 1 = Enable	DMA watch dog timer: 0 = Disable 1 = Enable When enabled, the 82C931 will generate internal DACK after the DRQ pending time-up.	Reserved	
(1) Bit 5 must be set in order to access the CIR16-31, the Expanded Mode of the Codec Indirect Registers. Refer to Table 5-9 and Table 5-11.								

**Table 5-6 MC Indirect Registers (cont.)**

7	6	5	4	3	2	1	0	
<b>MCIR6 MIDI Interface Register (WO) Default = 00h</b>								
MPU-401: 0 = Disable 1 = Enable	MPU-401 base address select: 00 = 330 10 = 310 01 = 320 11 = 300		MPU-401 interrupt select: 00 = IRQ9 10 = IRQ5 01 = IRQ10 11 = IRQ7		Reserved	Windows sound system mode: 0 = Disable 1 = Enable	Sound Blaster mode: 0 = Disable 1 = Enable	
<b>MCIR7 Semaphore Software Register (Software use only) Default = 00h</b>								
D7	D6	D5	D4	D3	D2	D1	D0	
<b>MCIR8 Reserved Register Default = 00h</b>								
<b>MCIR9 Test Control Register Default = 00h</b>								
Digital power-down: 0 = Normal 1 = Power-down	Analog power-down: 0 = Normal 1 = Power-down	Reserved				Software reset: 0 = Disable 1 = Enable		
<b>MCIR10 Test Control Register Default = 00h</b>								
Playback reset: 0 = Normal 1 = Reset (playback data path clear, active high)	Capture reset: 0 = Normal 1 = Reset (capture data path clear, active high)	PNP test mode: 0 = Normal 1 = Test (PNP logic is set to Sleep mode)	Reserved					
<b>MCIR11 Status Register (RO) Default = 00h</b>								
Playback DMA pending? 0 = No 1 = Yes	Capture DMA pending? 0 = No 1 = Yes	MPU interrupt pending? 0 = No 1 = Yes	CD interrupt pending? 0 = No 1 = Yes	Capture interrupt pending? 0 = No 1 = Yes	Playback interrupt pending? 0 = No 1 = Yes	Playback FIFO empty? 0 = No 1 = Yes	Capture FIFO empty? 0 = No 1 = Yes	
<b>MCIR12 Test Register Default = 00h</b>								
Reserved			Digital test mode output high/low byte select (WO)	Digital test mode output select (WO)				
<b>MCIR13 PNP Status Register (RO) Default = 01h</b>								
CSN not zero - active high: 1 = PNP configuration manager assigned a CSN to 82C931. <sup>(1)</sup>	Modem interface logical device: 0 = Disable 1 = Enable	IDE logic device: 0 = Disable 1 = Enable	MC logical device: 0 = Disable 1 = Enable	CONFIG mode: 1 = 82C931's PNP logic is in the CONFIG mode	ISOLATE mode: 1 = 82C931's PNP logic is in the ISOLATE mode	SLEEP mode: 1 = 82C931's PNP logic is in the SLEEP mode	WAIT4KEY mode: 1 = 82C931's PNP logic is in the WAIT4KEY mode	
(1) When a CSN is assigned to the 82C931, it switches to the PNP mode and the resource configuration is controlled through the PNP registers.								



Table 5-6 MC Indirect Registers (cont.)

7	6	5	4	3	2	1	0
<b>MCIR14</b> <span style="float: right;"><b>PNP CSN Register (RO)</b></span> <span style="float: right;"><b>Default = 00h</b></span> PNP card select number: This registers shows the CSN assigned to the 82C931 by the PNP configuration manager.							
<b>MCIR15</b> <span style="float: right;"><b>PNP Read Port Address Register (RO)</b></span> <span style="float: right;"><b>Default = 00h</b></span> PNP READ_DATA port: This registers shows the READ_DATA port assigned by the PNP configuration manager.							
<b>MCIR16</b> <span style="float: right;"><b>Volume Control Register</b></span> <span style="float: right;"><b>Default = 00h</b></span>							
Reserved	Push-bottom volume control interrupt enable	UP bottom is pushed? 0 = No 1 = Yes This bit is cleared after a read.	DOWN bottom is pushed? 0 = No 1 = Yes This bit is cleared after a read.	Master volume mute control (active high)	Push-bottom volume control interrupt status (RO) This bit is cleared after a read.	Volume control interrupt select: 00 = Disable 01 = IRQ5 10 = IRQ10 11 = IRQ11	
<b>MCIR17</b> <span style="float: right;"><b>Serial EEPROM Control Register</b></span> <span style="float: right;"><b>Default = 00h</b></span>							
Write to external serial EEPROM: 0 = Disable 1 = Enable	External serial EEPROM chip select: 0 = Disable 1 = Enable	External serial EEPROM clock: 0 = Disable 1 = Enable	External serial EEPROM data out: 0 = Disable 1 = Enable Connected to DIN of external EEPROM	External serial EEPROM data out: 0 = Disable 1 = Enable Connected to DIN of external EEPROM	External serial EEPROM capability (R/W) When read for status: 0 = Disable 1 = Enable When write to change: 0 = Enable 1 = Disable Note: read polarity is the opposite of write's.	PNP setting (R/W): <b>Read:</b> 0 = enabled 1 = disabled <b>Write:</b> 0 = disabled 1 = enabled Note: the polarity of the read is the opposite of the write.	Reserved
<b>MCIR18</b> <span style="float: right;"><b>CONFIG Status Register</b></span> <span style="float: right;"><b>Default = xxh</b></span>							
Modem interface capability (R/W): When read for status: 0 = Disable 1 = Enable When write to change: 0 = Enable 1 = Disable Note: read polarity is the opposite of write's	ASIO function: 0 = Disable 1 = Enable	Reserved 0 = Default	Mode 0 status (RO): reflects 931 pin#11 setting.  0 = 931-AD for adapter 1 = 931-MD for motherboard	Chip Revision ID (RO) Silicon rev. 0.1 = 0x8 Silicon rev. 1.1 = 0x9			

**Table 5-6 MC Indirect Registers (cont.)**

7	6	5	4	3	2	1	0
<b>MCIR19 FM Control Register</b> <span style="float: right;"><b>Default = xxh</b></span>							
IDE IRQ input routed to IRQ output: 0 = Disable 1 = Enable	SDHOE function on pin 43 when configured for MB Mode: 0 = Disable 1 = Enable	IRQ3, IRQ4: 0 = Disable 1 = Enable	Reserved		MEGA bass: 0 = Disable 1 = Enable	OPTi mode for enhanced FM features: 0 = Disable 1 = Enable	External FM select: 0 = Disable 1 = Enable
<b>MCIR20 GPIO Control Register 0</b> <span style="float: right;"><b>Default = 00h</b></span>							
GPIO3 mapping: 0 = Pin 42 931-AD 1 = Pin 36 931-MB	GPIO3 pin type: 0 = Input 1 = Output	GPIO2 mapping: 0 = Pin 41 931-AD 1 = Pin 35 931-MB	GPIO2 pin type: 0 = Input 1 = Output	GPIO1 mapping: Pin 11 for 931-AD and 931-MB	GPIO1 pin type: 0 = Input 1 = Output	GPIO0 mapping: Pin 43 for 931-AD and 931-MB	GPIO0 pin type: 0 = Input 1 = Output
<b>Note:</b> GPIO function is available only when the specified pin is not being used for another function.							
<b>MCIR21 Serial Audio Control Register 0</b> <span style="float: right;"><b>Default = 00h</b></span>							
CTL_SEL[1:0] ASIO shift clock selection 00/11 = Use the shift clock from internal FS 01 = Use FM timing 10 = Use external SCLK		P2S_SEL[1:0] SAO data source selection 00/11 = From DMA Playback 01 = From FM 10 = From ADC, captured from analog section		SPCDSEL Enables dual playback 0 = 2nd DMA channel is used for DMA capture 1 = 2nd DMA is used with 1st DMA channel for DMA playback	ADCSEL Selects DMA data capture source 0 = ADC data (from analog section) 1 = SAI data	FDACSEL Selects FDAC data source 0 = FDAC takes FM data 1 = FDAC takes SADI (if SPCDSEL=0), 2nd DMA playback data (if SPCDSEL=1)	DACSEL Selects DAC data source 0 = DMA playback 1 = SAI
<b>MCIR22 Serial Audio Control Register 1</b> <span style="float: right;"><b>Default = 00h</b></span>							
Reset ASIO: 0 = Normal 1 = Reset	ASIO test mode: 0 = Normal 1 = Test	F16 Specify ASIO sample period data location: 0 = Last 16 bits of the L/R half sample period 1 = First 16/17 bits of L/R half sample period	CLK32 Number of SCLKs in a sample period (delay-mode or pulse-mode ASIO only) 0 = 32 1 = >32	SCLK polarity: 0 = Reverse 1 = No changed	FSYNC polarity: 0 = Reverse 1 = No changed	PULSE Pulse mode type of serial data (AT&T7525 comp or CS8412 DSP) 0 = Not activated 1 = Activated	

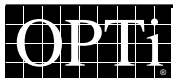

Table 5-6 MC Indirect Registers (cont.)

7	6	5	4	3	2	1	0
<b>MCIR23</b> Serial Audio Clock/Output Control Register <b>Default = 00h</b>							
ASDOOE ADO direction control 0 = Input 1 = Output	SCLKOE SCLK direction control 0 = Input 1 = Output	FSYNCOE FSYNC direction control 0 = Input 1 = Output	MCLKEN External MCLK enable (fed through ASDO) 0 = Disabled 1 = Enabled	MCLKSEL[1:0] Master clock divider selection 00 = asdo_clk/8 01 = asdo_clk/4 10 = asdo_clk/2 11 = asdo_clk/1		CLKSEL[1:0] Selects shift clock for serial audio data output (sclk_out) 00 = mclk/8 01 = mclk/4 10 = mclk/2 11 = mclk/1	
<b>MCIR24</b> Game Port Counter Setup and Status Register <b>Default = 00h</b>							
JRDY/Game Port IRQ Readback of '1' indicates the game port counters are stopped and the interrupts is generated. The IRQ is cleared by writing a '1' to this location.	SOUNDIRQ Shows the status of the audio IRQ, a '1' indicates there is a soundIRQ	GPIRQEN IRQ generation when the game port counter is finish counting 0 = Disabled 1 = Enabled	GPWPEN Auto game port trigger (20x write) 0 = Disabled 1 = Enabled	ACTBY By axis counter enable 0 = Disabled 1 = Enabled	ACTBX Bx axis counter enable 0 = Disabled 1 = Enabled	ACTAY Ay axis counter enable 0 = Disabled 1 = Enabled	ACTAX Ax axis counter enable 0 = Disabled 1 = Enabled
<b>MCIR25</b> Game Port Counter Values Register <b>Default = xxh</b>							
<p>GPCOUNT[7:0] Hardware counter values in H-byte L-byte fashion (16-bit). The sequence will be: Joystick A-X axis Joystick A-Y axis Joystick B-X axis Joystick B-Y axis</p> <p>The count value will be changed automatically upon each read of this register. If that particular joystick axis is masked (disabled), the count will skip accordingly.</p>							
<b>MCIR26</b> FDAC Data Control Register <b>Default = 00h</b>							
JPTSTEN Game port counter test mode, counter toggled by 14.318MHz (default=1MHz) 0 = Disabled 1 = Enabled	Reserved	VCPIN Special volume control pins move the pins to up/down=GD5/4 (normal: up/down = GD7/6) 0 = Disabled 1 = Enabled	ASWTST FDAC data auto-switching timer test mode, TxD timer toggled by 14.318MHz (default = 31KHz) 0 = Disabled 1 = Enabled	FDACMUL Multiply FDAC data by 2 0 = Disabled 1 = Enabled	FMMUL Multiply FM data by 2 0 = Disabled 1 = Enabled	FMDIV Divide FM data by 2 0 = Disabled 1 = Enabled	AUTOSW Auto-detect of TxD activity to switch the FDAC data between FM and serial audio (which comes from TxD) 0 = Disabled 1 = Enabled

## 5.3 SBBase Register

SBBase is mainly used to access the Digital Audio Processor (DAP) registers, however, as shown in Table 5-7 other types of registers are also accessible through SBBase. The indexing scheme is the same as when accessing MCBase regis-

ters (CPU Direct I/O R/W). Note that in Table 5-7, which gives the SBBase register bit formats, some registers may also be accessed through ALBase. However, use only one Base register for accessing.

**Table 5-7 SBBase Registers for FM and DAP Applications**

7	6	5	4	3	2	1	0
<b>SBBase+00h (or ALBase+00h) Left FM Status Register (RO)</b>							
<b>SBBase+00h (or ALBase+00h) Left FM Address Port Register (WO)</b>							
<b>SBBase+01h (or ALBase+01h) Left FM Data Port Register (WO)</b>							
<b>SBBase+02h (or ALBase+02h) Right FM Address Port Register (WO)</b>							
<b>SBBase+03h (or ALBase+03h) Right FM Data Port Register (WO)</b>							
<b>SBBase+04h Mixer Address Port Register (WO)</b>							
<b>SBBase+05h Mixer Data Port Register (WO)</b>							
<b>SBBase+06h DAP Reset Register</b>							
Don't care							DAP software reset at end of the I/O write command: 0 = Disable 1 = Enable <sup>(1)</sup>
(1) When bit 0 is enabled, it sets a software reset flag. This software reset is terminated by performing another write at this location with bit 0 = 0. A system reset will reset the software reset flag, thus terminating the software reset							
<b>SBBase+08h FM Status Port Register (RO)</b>							
<b>SBBase+08h FM Address Port Register (WO)</b>							
<b>SBBase+09h FM Data Port Register (WO)</b>							
<b>SBBase+0Ah DAP Read Data Register (RO)</b>							
<b>SBBase+0Ch DAP Data/Command Register (WO)</b>							
<b>SBBase+0Ch DAP Write Buffer Status Register (RO)</b>							
DAP Input buffer full: <sup>(1)</sup> 0 = Empty 1 = Full		SBBase+A[6:0]					
(1) This flag is set when the host CPU writes data in the input data bus buffer and cleared when the data is read by the internal DAP.							

**Table 5-7 SBBase Registers for FM and DAP Applications (cont.)**

7	6	5	4	3	2	1	0
<b>SBBase+0Eh</b> <b>DAP Output Buffer Status Register (RO)</b>							
DAP output buffer is full: <sup>(1)</sup> 0 = Empty 1 = Full		Output Buffer					
(1) This flag is set in the DAP when data is written in the output data bus buffer and cleared when the host CPU or the DMA controller reads the data in the output data bus buffer.							
<b>Note:</b> Reading this register will also clear the Digital Audio Processor interrupt request.							

## 5.4 WSBase Register

Two types of registers can be accessed through WSBase:

- Windows Sound System (WSS) and Codec registers

Direct I/O R/W). The bit formats for WSS-related registers are given in Table 5-8 and Table 5-9 shows the Codec-related registers.

These registers are accessed through the WSBase register and use the same type of indexing scheme as MCBASE (CPU

**Table 5-8 WSBase Registers for Windows Sound System Applications**

7	6	5	4	3	2	1	0
<b>WSBase+00h-03h</b> <b>WSS Configuration Register (W0)</b> <b>Default = 00h</b>							
Reserved	IRQ sense source: 0 = Normal 1 = auto-interrupt selection	WSS IRQ select: 000 = Disable 001 = IRQ7 010 = IRQ9 011 = IRQ10 100 = IRQ11 101 = IRQ5 110 = Reserved 111 = Reserved			WSS DRQ select: <b>Playback</b> <b>Capture</b> 000 = Disable    Disable 001 = DRQ0    Disable 010 = DRQ1    Disable 011 = DRQ3    Disable 100 = Disabled    DRQ1 101 = DRQ0    DRQ1 110 = DRQ1    DRQ0 111 = DRQ3    DRQ0		
<b>WSBase+00h-03h</b> <b>WSS Version Register (R0)</b> <b>Default = 00h</b>							
Channel available: 0 = DRQ0/1/3 and IRQ7/9/10/11 available 1 = DRQ1/3 and IRQ7/9 available	IRQ sense: 0 = No interrupt 1 = WSS interrupt active	Version: 04h					



**Table 5-9 WSBASE Register for Codec/Mixer Applications (cont.)**

7	6	5	4	3	2	1	0
<b>WSBase+06h</b>							<b>Default = 44h</b>
<b>Codec Status Register (R/W, exists in Codec only)</b>							
PIO capture data is ready for upper or lower byte (RO): 0 = Lower 1 = Upper (or any 8-bit mode)	PIO capture data is waiting for right or left channel ADC (RO): 0 = Right 1 = Left (or mono)	PIO Capture Data Register contains data ready for reading by host (RO): <sup>(1)</sup> 0 = Stale ADC data (do not re-read) 1 = Fresh ADC data (ready for next host data read)	Sample over/underrun (RO): Indicates that the most recent sample was not serviced in time; therefore either an overrun for ADC capture or underrun for DAC playback has occurred. <sup>(2)</sup>	PIO playback data is needed for upper or lower byte (RO): 0 = Lower 1 = Upper (or any 8-bit mode)	PIO playback data is needed for right or left channel DAC (RO): 0 = Right 1 = Left (or mono)	PIO Playback Data Register ready for more data (RO): <sup>(1)</sup> 0 = Valid DAC data (do not overwrite) 1 = Stale DAC data (ready for next host data write value)	Interrupt: 0 = Disable 1 = Enable
<p>(1) These bits (5 and 1) should only be programmed when direct programmed I/O data transfers are desired.</p> <p>(2) If both capture and playback are enabled, the source which set bit 4 can be determined by reading COR and PUR. Bit 4 changes on a sample-by-sample basis.</p> <p><b>Note:</b> Bits 5, 1, and 0 can change asynchronously to host accesses. The host may access this register while the bits are transitioning. The host read may return a zero value just as these bits are changing (e.g., a value of 1 would not be read until the next host access). This register's initial state after reset is "1100 1100".</p>							
<b>WSBase+07h</b>							<b>Default = 00h</b>
<b>Codec Direct Data Register - Capture Mode (RO, exists in Codec only)</b>							
<p>The Codec Direct Data Registers are two registers mapped to the same address. Writes send data to the PIO Playback Data Register (PD7:0). Reads will receive data from the PIO Capture Data Register (CD7:0).</p> <p>During initialization, the PIO Playback Data Register cannot be written and the Capture Data Register is always read "1000 0000" (80h).</p> <p><b>PIO Capture Data Register:</b> This is the control register where capture data is read during programmed I/O data transfers.</p> <p>The reading of this register will increment the state machine so that the following read will be from the next appropriate byte in the sample. The exact byte which is next to be read can be determined by reading the Status Register. Once all relevant bytes have been read, the state machine will stay pointed to the last byte of the sample until a new sample is received from the ADCs. Once this has occurred, the state machine and status register will point to the first byte of the sample. Until a new sample is received, reads from this register will return the most significant byte of the sample.</p>							
<b>WSBase+07h</b>							<b>Default = 00h</b>
<b>Codec Direct Data Register - Playback Mode (WO, exists in Codec only)</b>							
<p>The Codec Direct Data Registers are two registers mapped to the same address. Writes send data to the PIO Playback Data Register (PD7:0). Reads will receive data from the PIO Capture Data Register (CD7:0).</p> <p>During initialization, the PIO Playback Data Register cannot be written and the Capture Data Register is always read "1000 0000" (80h).</p> <p><b>PIO Playback Data Register:</b> This is the control register where playback data is written during programmed I/O data transfers.</p> <p>Writing data to this register will increment the playback byte tracking state machine so that the following write will be to the correct byte of the sample. Once all bytes of a sample have been written, subsequent byte writes to this port are ignored. The state machine is reset when the current sample is sent to the DACs.</p>							

**Table 5-10 Codec Indirect Registers**

D7	D6	D5	D4	D3	D2	D1	D0
<b>CIR0 MIXOUTL Output Control Register Default = 00h</b>							
Source select: 00 = LINE    10 = MIC 01 = CD      11 = MIXER		MIC +20dB Gain: 0 = Disable 1 = Enable	Reserved	Gain select for MIXOUTL (dB): 0000 = 0            0110 = +9.0            1011 = +16.5 0001 = +1.5        0111 = +10.5           1100 = +18.0 0010 = +3.0        1000 = +12.0           1101 = +19.5 0011 = +4.5        1001 = +13.5           1110 = +21.0 0100 = +6.0        1010 = +15.0           1111 = +22.5 0101 = +7.5			
<b>CIR1 MIXOUTR Output Control Register Default = 00h</b>							
Source select: 00 = LINE    10 = MIC 01 = CD      11 = MIXER		MIC +20dB Gain: 0 = Disable 1 = Enable	Reserved	Gain select for MIXOUTR (dB): Refer to CIR0[3:0] for decode.			
<b>CIR2 CDL Input Control Register Default = 88h</b>							
Mute: 0 = Disable 1 = Enable	Reserved		Gain select for CDL (dB): 0000 = +12        0110 = -6            1011 = -21 0001 = +9          0111 = -9            1100 = -24 0010 = +6          1000 = -12           1101 = -27 0011 = +3          1001 = -15           1110 = -30 0100 = 0            1010 = -18           1111 = -33 0101 = -3 Note: This decode is also applicable for the MIC, LINE, AUX, and FM inputs.				Reserved
<b>CIR3 CDR Input Control Register Default = 88h</b>							
Mute: 0 = Disable 1 = Enable	Reserved		Gain select CDR (dB): Refer to CIR2[4:1] for decode.				Reserved
<b>CIR4 FML Input Control Register Default = 88h</b>							
Mute: 0 = Disable 1 = Enable	Reserved		Gain select FML (dB): Refer to CIR2[4:1] for decode.				Reserved
<b>CIR5 FMR Input Control Register Default = 88h</b>							
Mute: 0 = Disable 1 = Enable	Reserved		Gain select FMR (dB): Refer to CIR2[4:1] for decode.				Reserved



Table 5-10 Codec Indirect Registers (cont.)

D7	D6	D5	D4	D3	D2	D1	D0
<b>CIR6 DACL Input Control Register</b> <span style="float: right;">Default = 80h</span>							
Mute: 0 = Disable 1 = Enable	Reserved		Gain select for DAC inputs (dB):				
			*00000 = 0	01000 = -12.0	10000 = -24.0	11000 = -36.0	
			00001 = -1.5	01001 = -13.5	10001 = -25.5	11001 = -37.5	
			00010 = -3.0	01010 = -15.0	10010 = -27.0	11010 = -39.0	
			00011 = -4.5	01011 = -16.5	10011 = -28.5	11011 = -40.5	
			00100 = -6.0	01100 = -18.0	10100 = -30.0	11100 = -42.0	
			00101 = -7.5	01101 = -19.5	10101 = -31.5	11101 = -43.5	
			00110 = -9.0	01110 = -21.0	10110 = -33.0	11110 = -45.0	
			00111 = -10.5	01111 = -22.5	10111 = -34.5	11111 = -46.5	
<b>CIR7 DACR Input Control Register</b> <span style="float: right;">Default = 80h</span>							
Mute: 0 = Disable 1 = Enable	Reserved		Gain select for DAC inputs (dB): Refer to CIR6[4:0] for decode.				
<b>CIR8 Fs and Playback Data Format Register</b> <span style="float: right;">Default = 00h</span>							
Audio data format - linear PCM or companded for all input and output data (used in conjunction with bit 5): <sup>(1)</sup>		Stereo/mono: <sup>(2)</sup> 0 = Mono 1 = Stereo		Clock frequency divide / audio sample rate frequency:			
000 = Linear, 8-bit unsigned				0000 = 8.0kHz	0001 = 5.5125kHz		
001 = $\mu$ -law, 8-bit companded				0010 = 16.0kHz	0011 = 11.025kHz		
010 = Linear, 16-bit two's complement, Little Endian				0100 = 27.42857kHz	0101 = 18.9kHz		
011 = A-Law, 8-bit companded				0110 = 32.0kHz	0111 = 22.05kHz		
100 = Reserved				1000 = Reserved	1001 = 37.8kHz		
101 = ADPCM, 4-bit, IMA compatible				1010 = Reserved	1011 = 44.1kHz		
110 = Linear, 16-bit two's complement, Big Endian				1100 = 48.0kHz	1101 = 33.075kHz		
111 = Reserved				1110 = 9.6kHz	1111 = 6.615kHz		
<b>Note:</b> Bit 7 is not available in Mode 1 (forced to 0).							
(1) SB/WSS mode switch: In Sound Blaster mode, the software driver should set CDF to 8 bit PCM mode (R8: FM1,FM-,C_L).							
(2) Selecting stereo results with alternating samples representing left and right audio channels. Mono playback plays the same audio sample on both channels. Mono capture only captures data from the left audio channel.							
<b>Note:</b> The contents of this register can only be changed if the mode change bit (WSBase+04h[6]) is enabled (set to 1). Writes to this register without the mode change bit enabled will have no affect.							
<b>CIR9 Interface Configuration Register</b> <span style="float: right;">Default = 00h</span>							
Transfer capture data via DMA or PIO: 0 = DMA 1 = PIO	Transfer playback data via DMA or PIO: 0 = DMA 1 = PIO	Reserved		Autocalibrate: 0 = Disable 1 = Enable (autocalibration after power down/reset or mode change)	DMA channel mode: <sup>(1)</sup> 0 = Dual 1 = Single	Capture data in format selected: <sup>(2)</sup> 0 = Disable 1 = Enable	Playback data in format selected: <sup>(3)</sup> 0 = Disable 1 = Enable
(1) In Sound Blaster mode, bit 2 is set when playback or capture DMA starts and is reset when DMA ends.							
(2) The codec generates CDRQ and responds to CDAK# when bit 1 = 1 and bit 7 = 0. If bit 7 = 1, bit 1 enables PIO capture mode.							
(3) The codec generates PDRQ and repents to PDAK# when bit 0 = 1 and bit 6 = 0. If bit 6 = 1, bit 1 enables PIO playback mode							

Table 5-10 Codec Indirect Registers (cont.)

D7	D6	D5	D4	D3	D2	D1	D0
<b>CIR10 Pin Control Register</b> <span style="float: right;"><b>Default = 00h</b></span>							
Reserved						Interrupt pin: <sup>(1)</sup> 0 = Disable 1 = Enable (Interrupt pin goes active high when the number of samples programmed in the Base Count Register is reached.)	Reserved
2. In Sound Blaster mode, the software driver should set bit 1 = 1.							
<b>CIR11 Error Status and Initialization Register (RO)</b> <span style="float: right;"><b>Default = 00h</b></span>							
Capture overrun: <sup>(1)</sup> This bit is set when capture data has not been read by the host before the next sample arrives. The sample being read will not be overwritten by the new sample. The new sample is ignored.	Playback underrun: <sup>(1)</sup> This bit is set when playback data has not arrived from the host in time to be played. This results in a midscale value sent to the DACs.	Autocalibration state: 0 = In progress 1 = Not in progress	Current status of PDRQ and CDRQ: 0 = Inactive (low) 1 = Active (high)	Indicates under/over range on right input channel: <sup>(1)</sup> 0 = Less than -1dB under range 1 = Between -1dB and 0dB under range 2 = Between 0dB and +1dB over range 3 = Greater than +1dB over range	Indicates under/over range on left input channel: <sup>(1)</sup> 0 = Less than -1dB under range 1 = Between -1dB and 0dB under range 2 = Between 0dB and +1dB over range 3 = Greater than +1dB over range		
(1) Bit changes on a sample-by-sample basis.							
(2) The occurrence of a capture overrun and/or playback underrun is designated in the Status Register's sample overrun/underrun bit (WSBase+06h[4]). The sample overrun/underrun bit is the logical OR of bits 7 and 6. This enables a polling host CPU to detect an overrun/underrun condition while checking other status bits.							
<b>CIR12 ID Register</b> <span style="float: right;"><b>Default = 0Ah</b></span>							
Reserved				Revision ID (RO): These bits define the revision level of the codec.			
<b>CIR13</b> <span style="float: right;"><b>Reserved</b></span> <span style="float: right;"><b>Default = 00h</b></span>							
<b>CIR14 Playback Upper Base Count Register</b> <span style="float: right;"><b>Default = 00h</b></span>							
Upper Base Count: This byte is the upper byte of the base count register containing the eight most significant bits of the 16-bit base register. Reads from this register return the same value which was written. The current count contained in the counters can not be read. When enabled for SB Mode, this register is used for both the Playback and Capture Base Registers.							

Table 5-10 Codec Indirect Registers (cont.)

D7	D6	D5	D4	D3	D2	D1	D0
<b>CIR15 Playback Lower Base Count Register</b> <span style="float: right;"><b>Default = 00h</b></span> Lower Base Count: This byte is the lower byte of the base count register containing the eight least significant bits of the 16-bit base register. Reads from this register return the same value which was written. The current count contained in the counters can not be read. When enabled for SD Mode, this register is used for both the Playback and Capture Base Registers.							

Table 5-11 Expanded Mode CIR

7	6	5	4	3	2	1	0
<b>CIR16 AUXL Input Control Register</b> <span style="float: right;"><b>Default = 88h</b></span>							
Mute: 0 = Disable 1 = Enable	Reserved		Gain select for AUXL (dB): Refer to CIR2[4:1] for decode.			Reserved	
<b>CIR17 AUXR Input Control Register</b> <span style="float: right;"><b>Default = 88h</b></span>							
Mute: 0 = Disable 1 = Enable	Reserved		Gain select for AUXR (dB): Refer to CIR2[4:1] for decode.			Reserved	
<b>CIR18 LINEL Input Control Register</b> <span style="float: right;"><b>Default = 88h</b></span>							
Mute: 0 = Disable 1 = Enable	Reserved		Gain select for LINEL (dB): Refer to CIR2[4:1] for decode.			Reserved	
<b>CIR19 LINER Input Control Register</b> <span style="float: right;"><b>Default = 88h</b></span>							
Mute: 0 = Disable 1 = Enable	Reserved		Gain select for LINER inputs (dB): Refer to CIR2[4:1] for decode.			Reserved	
<b>CIR20 MICL Input Control Register</b> <span style="float: right;"><b>Default = 88h</b></span>							
Mute: 0 = Disable 1 = Enable	MICR mixed into OUTL: 0 = Disable 1 = Enable	Reserved	Gain select for MICL (dB): Refer to CIR2[4:1] for decode.			Reserved	
<b>CIR21 MICR Input Control Register</b> <span style="float: right;"><b>Default = 88h</b></span>							
Mute: 0 = Disable 1 = Enable	MICL mixed into OUTR: 0 = Disable 1 = Enable	Reserved	Gain select for MICR (dB): Refer to CIR2[4:1] for decode.			Reserved	

**Table 5-11 Expanded Mode CIR (cont.)**

7	6	5	4	3	2	1	0
<b>CIR22 OUTL Output Control Register Default = 80h</b>							
Mute: 0 = Disable 1 = Enable	Reserved	Gain select for OUTL (dB):				Reserved	
		00000 = 0	01000 = -24	10000 = -48	11000 = -72		
		00001 = -3	01001 = -27	10001 = -51	11001 = -75		
		00010 = -6	01010 = -30	10010 = -54	11010 = -78		
		00011 = -9	01011 = -33	10011 = -57	11011 = -81		
		00100 = -12	01100 = -36	10100 = -60	11100 = -84		
		00101 = -15	01101 = -39	10101 = -63	11101 = -87		
		00110 = -18	01110 = -42	10110 = -66	11110 = -90		
		00111 = -21	01111 = -45	10111 = -69	11111 = -93		
<b>CIR23 OTR Output Control Register Default = 80h</b>							
Mute: 0 = Disable 1 = Enable	Reserved	Gain select for OTR (dB): Refer to CIR22[5:1] for decode.				Reserved	
<b>CIR24-CIR27 Reserved Default = 00h</b>							
<b>CIR28 Capture Data Format Default = 00h</b>							
Audio data format - linear PCM or companded for all input and output data (used in conjunction with bit 5): <sup>(1)</sup>		Stereo/mono: <sup>(2)</sup>		Reserved			
000 = Linear, 8-bit unsigned		0 = Mono					
001 = $\mu$ -law, 8-bit companded		1 = Stereo					
010 = Linear, 16-bit two's complement, Little Endian							
011 = A-Law, 8-bit companded							
100 = Reserved							
101 = ADPCM, 4-bit, IMA compatible							
110 = Linear, 16-bit two's complement, Big Endian							
111 = Reserved							
<b>Note:</b> Bit 7 is not available in Mode 1 (forced to 0).							
(1) SB/WSS mode switch: In Sound Blaster mode, the software driver should set CDF to 8 bit PCM mode (R8: FM1,FM-,C_L).							
(2) Selecting stereo results with alternating samples representing left and right audio channels. Mono playback plays the same audio sample on both channels. Mono capture only captures data from the left audio channel.							
<b>Note:</b> The contents of this register can only be changed if the mode change bit (WSBase+04h[6]) is enabled (set to 1). Writes to this register without the mode change bit enabled will have no affect.							
<b>CIR29 Reserved Default = 00h</b>							
<b>CIR30 Capture Upper Base Count Default = 00h</b>							
Upper Base Count: This byte is the upper byte of the base count register containing the eight most significant bits of the 16-bit base register. Reads from this register return the same value which was written.							
<b>CIR31 Capture Lower Base Count Default = 00h</b>							
Upper Base Count: This byte is the lower byte of the base count register containing the eight most significant bits of the 16-bit base register. Reads from this register return the same value which was written.							

## 6.0 Electrical Specifications

Stresses above those listed in the following tables may cause permanent damage to the device. These are stress ratings only and functional operation of the device at these or any other conditions above those indicated in the operational sections of this specification are not implied.

### 6.1 Absolute Maximum Ratings

Symbol	Parameter	Min	Max	Unit
VCC	Supply Voltage	4.5	5.5	V
AVCC	Analog Supply Voltage	4.75	5.25	V
VIN	Input Voltage	-0.5	VCC + 0.5	V
VOUT	Output Voltage	-0.5	VCC + 0.5	V
TOP	Operating Temperature	0	70	°C
TSTG	Storage Temperature	-40	125	°C
ESD*	ESD Tolerance (Human Body Model MIL883C, 3015.7, Notice 8)		1000	V

\* ESD sensitive device. Electrostatic charges as high as 4000V readily accumulate on the human body and test equipment and can discharge without detection. Although the 82C931 features ESD protection circuitry, permanent damage may occur on devices subjected to high energy electrostatic discharges. Therefore, proper ESD precautions are recommended to avoid performance degradation or loss of functionality.

### 6.2 DC Characteristics: 5.0 Volt (VCC = 5.0V ±5%, TA = 0°C to +70°C)

Symbol	Parameter	Min	Max	Unit	Condition
VIL	Low Level Input Voltage	-0.3	0.8	V	VCC = 5.5V
VIH	High Level Input Voltage	2.4	VCC + 0.3	V	VCC = 4.5V
VIHa	High Level Input Voltage for RESET	3.5	VCC + 0.3	V	VCC = 4.5V
VOL	Low Level Output Voltage		0.2	V	IOL = 4mA, VCC = 4.5
VOH	High Level Output Voltage	VCC - 0.5	5.5	V	IOH = -4mA VCC = 5.5V
IIL	Input Leakage Current		10	µA	VCC = 5.5V
IILa	Input Leakage Current with 5K ohm Pull-up Resistor	-100	-500	µA	VIN = 0V
IILb	Input Leakage Current with 50K ohm Pull-up Resistor	-10	-50	µA	VIN = 0V
IOL	Output Leakage Current		10	µA	VCC = 5.5V
IPD	Static or Power-down Mode Current		300	µA	VCC = 5.5V

## 6.3 General Specifications: 5.0 Volt (VCC = 5.0V ±5%, TA = 0°C to +70°C)

Symbol	Parameter	Min	Typ	Max	Unit	Condition
IIL	Low Level Input Current	-10		10	μA	VIN = GND
IIH	High Level Input Current	-10		10	μA	VIN = VCC
IOZ	Tristate Output Leakage Current	-10		10	μA	VOUT = 0/VCC
V-	Schmitt Negative Threshold	0.8 1.5		1.3 2.5	V	TTL-STATIC CMOS-STATIC
V+	Schmitt Positive Threshold	1.4 2.5		2.1 3.5	V	TTL-STATIC CMOS-STATIC
VH	Schmitt Hysteresis		0.6 1.0		V	TTL-STATIC CMOS-STATIC
VIL	low Level Input Voltage			0.8	V	TTL-STATIC
VIH	High Level Input Voltage	2.0			V	TTL-STATIC
VOL	Low Level Output Voltage			0.4	V	TTL-STATIC
VOH	High Level Output Voltage	2.4			V	TTL-STATIC
RPD	Pull-down Resistance	50		200	KΩ	VIN = VCC
RPU	Pull-up Resistance	50		200	KΩ	VIN = VCC
CIN	Input Capacitance			5	pF	Frequency = 1MHz @ 0V
COUT	Output Capacitance			5	pF	Frequency = 1MHz @ 0V
CIO	Bidirectional Capacitance			5	pF	Frequency = 1MHz @ 0V
IOS	Short Circuit Output Current		2	25	mA	VOUT = 0V
IKLU	I/O Latch-Up Current	100			mA	V < GND, V > VCC
VESD	Electrostatic Protection	2000			V	C = 100pF, R = 1.5KΩ

## 6.4 Pin Specifications - Analog (VCC = 5.0V, 25°C)

Pin Name	Parameter	Min	Typ	Max	Unit	Condition
<b>Inputs</b>						
MICR, MICL, LINER, LINEL, CDR, CDL, AUXR, AUXL, CINR, CINL	Signal Bandwidth Input Range	10 0.5		20K 3.0	Hz V	Sine Wave
<b>Outputs</b>						
OUTR, OUTL	Signal Bandwidth Output Range	10 0.5		20K 3.0	Hz V	Sine Wave Load = 10KΩ, 25pF
MIXOUTR, MIXOUTL	Signal Bandwidth Output Range	10		20K	Hz	Sine Wave
VREF1 VREF2			1.75 1.85		V	DC DC

## 6.5 Volume Setting

Parameter	Min	Typ	Max	Unit	Test Conditions
Input Gain/Atten. Range: 16 levels (MIC, LINE, CD, AUX) 16 levels (ADC) 32 levels (DAC) 32 levels (LOUT)	-33 0 -93 -46.5		12 22.5 0 0	dB	Input @ 1Hz, 2.5Vpp wrt ACOM
Step Size: 16 levels (MIC, LINE, CD, AUX) 16 levels (ADC) 32 levels (DAC) 32 levels (LOUT)	2.6 1.3 2.6 2.0 1.3	3.0 1.5 3.0 3.0 1.5	3.4 1.7 3.4 4.0 1.7	dB	90 to -81dB (-84 to -93dB)
Mute Level		-80		dB	
Signal to Noise Ratio		-80		dB	
Total Harmonic Distortion		0.04		%	
Total Dynamic Range		80		dB	
Interchannel Isolation		60		dB	
Interchannel Gain Mismatch	-0.5		0.5	dB	
Gain Drift		100		ppm/°C	

## 6.6 Analog Characteristics

### Test conditions

Temp=25 °C, VDD, VCC=+5V, Input signal= 1kHz sine wave, Analog output passband: 20 Hz to 20kHz, Sample freq = 44.1 kHz

# 82C931

## DAC test conditions

16-bit linear mode, Full Scale input, 10 k $\Omega$  output load, measured at Line Out.

## ADC test conditions

16-bit linear mode, 0 dB Gain, Line Input.

### 6.6.1 Analog Inputs

Parameters	Min	Typ	Max	Units
Input voltage LINE/CD/AUX/CIN	2.6	2.8	3.1	Vp-p
MIC with 0dB gain	2.6	2.8	3.1	Vp-p
MIC with 20dB gain	0.26	0.28	0.31	Vp-p
Input impedance	10	20		k $\Omega$
Input capacitance			15	pF

### 6.6.2 Analog Outputs (10k $\Omega$ , 25pF)

Parameters	Min	Typ	Max	Units
Full-scale output voltage (OUTR & OUTL)	2.5	2.8	3.1	Vp-p
Vref		1.85		Volts
Output impedance			600	W
External load impedance	10			k $\Omega$

### 6.6.3 Volume Settings

Parameter	Min	Typ	Max	Units
Master volume step size	1.3	1.5	1.7	dB
Master volume output atten range		46.5		dB
Mute level		80		dB





### 6.6.4 Analog-to-Digital Converters

Parameters	Min	Typ	Max	Units
Resolution		16		bits
Total dynamic range	75	85		dB
THD			.025	%
Interchannel isolation: Line to Line/CD/Aux/Mic		80		dB
Interchannel gain mismatch	-0.5		+0.5	dB
Gain drift		100		ppm/°C

### 6.6.5 Digital-to-Analog Converters

Parameters	Min	Typ	Max	Units
Resolution		16		bits
Total dynamic range	78	95		dB
THD			.022	%
Interchannel isolation:		80		dB
Interchannel gain mismatch	-0.5		+0.5	dB
Gain drift		100		ppm/°C

## 6.7 AC Timings

Symbol	Parameter	Min	Max	Unit	Condition
<b>ISA Bus</b>					
tOSCP	OSC (14.318MHz) Frequency	14.0	14.5	MHz	
tOSCH	OSC High Width	32	40	ns	
tOSCL	OSC Low Width	32	40	ns	
tSCKP	SYSClk Frequency	8	9	MHz	
tSCKH	SYSClk High Width	50	70	ns	
tSCKL	SYSClk Low Width	55	70	ns	
tRST	RESET to RESET#	40	80	ns	
tCMDW	IOR#/IOW# Command Width	120		ns	
tWDSU	Write Data Setup to IOW# Rising	30		ns	
tWDHD	Write Data Hold from IOW# Rising	15		ns	
tRAC	Read Access Time	20	50	ns	



Symbol	Parameter	Min	Max	Unit	Condition
tASU	Address Setup to IOR#/IOW# Falling	50		ns	
tAHD	Address Hold from IOR#/IOW# Rising	30		ns	
tDKSU	DACK# Setup to IOR#/IOW# Falling	40		ns	
tDKHD	DACK# Hold from IOR#/IOW# Rising	160		ns	
tDHR	SD Hold from IOR# Rising	0	20	ns	
tDRHD	DRQ Hold from IOR#/IOW# Falling	0	25	ns	
<b>CD-ROM</b>					
tCA	SA to CA Delay	3	20	ns	
tXCS	SA to IDECS1#/3#	5	20	ns	
tCMDD	IOR#/IOW# to XIOR#/XIOW# Delay	3	20	ns	

**Figure 6-1 RESET and CLK Timing Waveform**

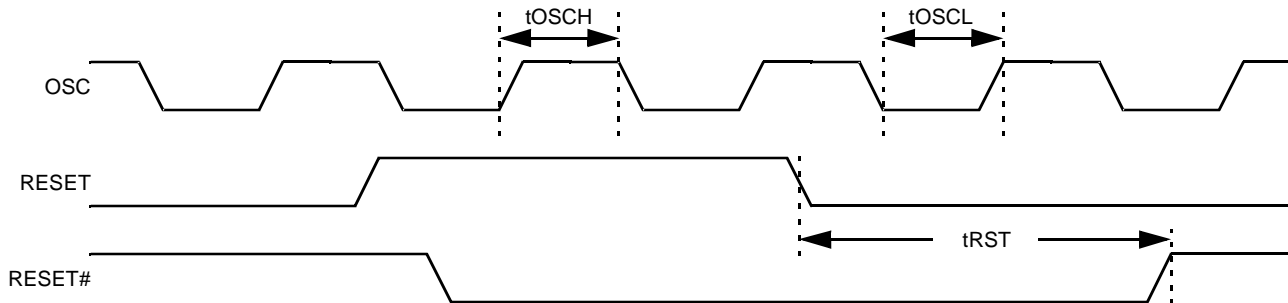
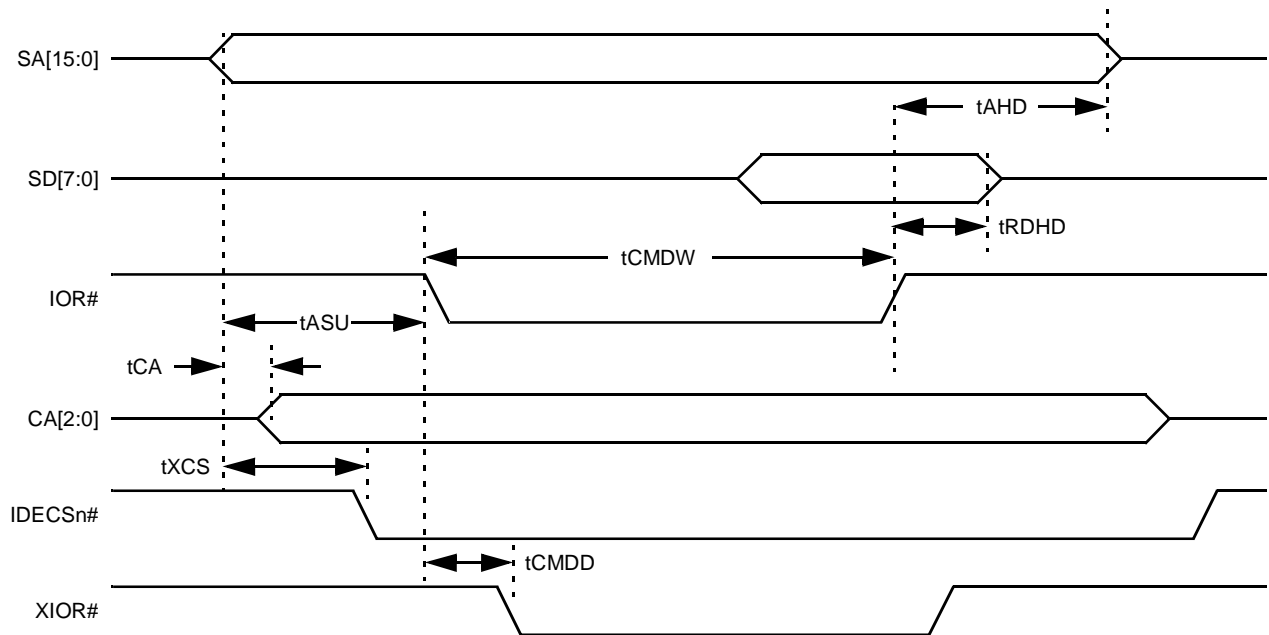
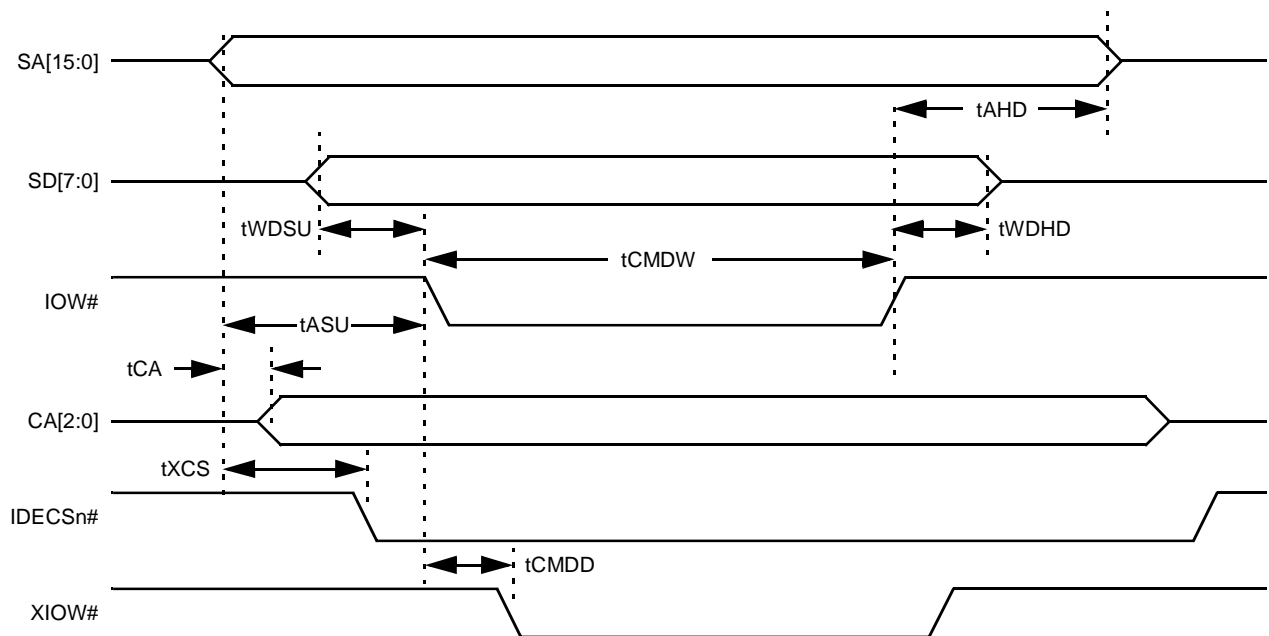

Figure 6-2 CD-ROM I/O Read Cycle



**Note:** For the above timing, AEN = 0, DRQ = 0, and DACKn# = 1.

Figure 6-3 CD-ROM I/O Write Cycle



**Note:** For the above timing, AEN = 0, DRQ = 0, and DACKn# = 1.

**Figure 6-4 DMA Write/Playback Cycle**

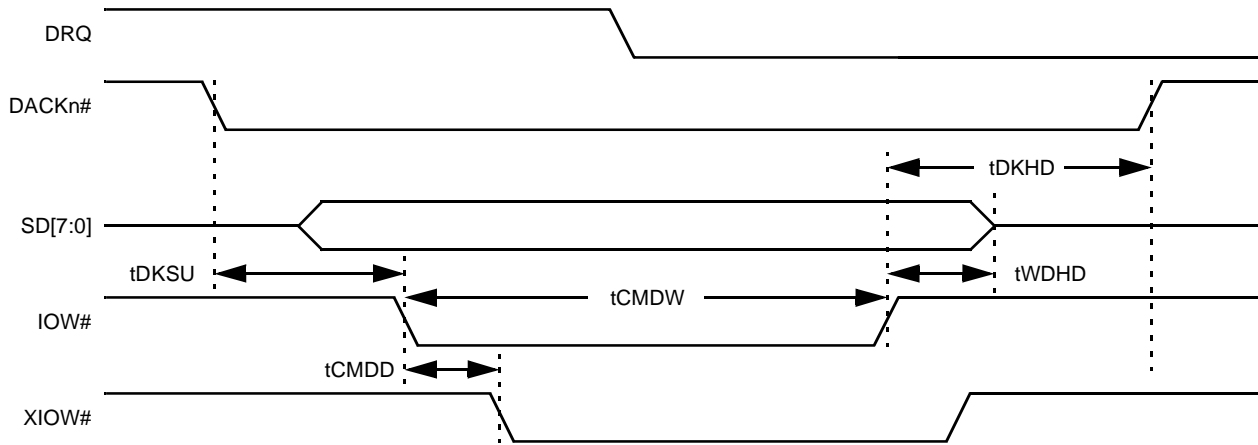

**Note:** For the above timing, AEN = 1.

**Figure 6-5 DMA Read/Capture Cycle**

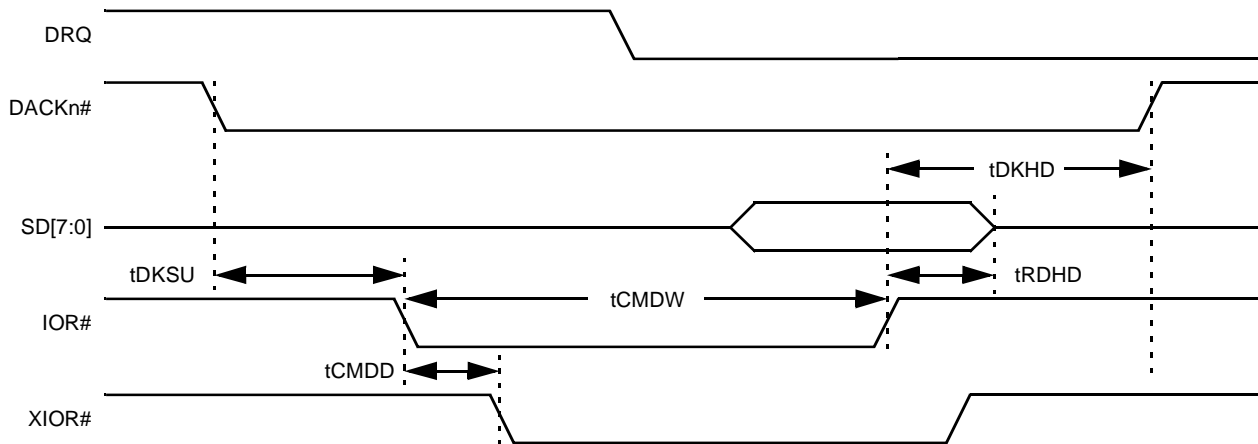

**Note:** For the above timing, AEN = 1.

## 7.0 Mechanical Packages

Figure 7-1 100-pin PQFP, Plastic Quad Flat Pack

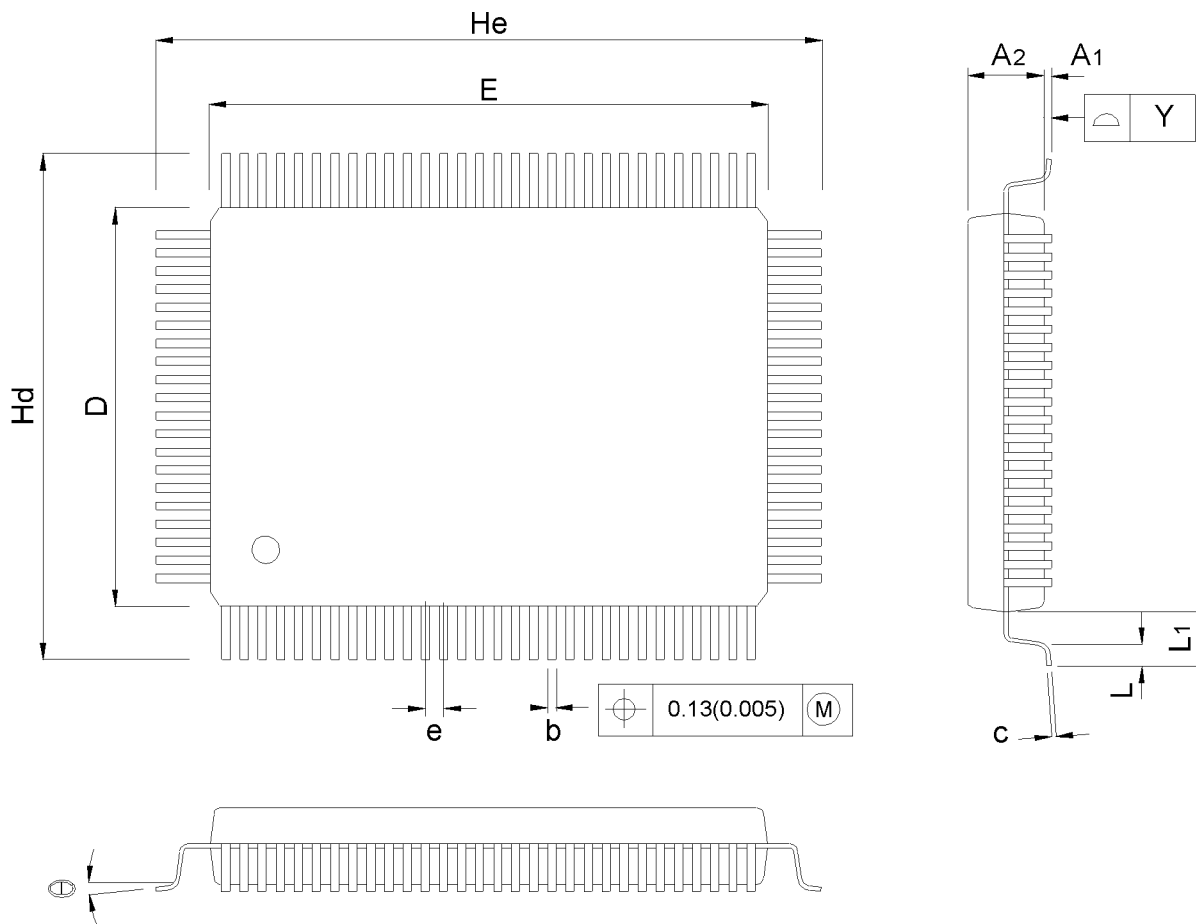

SYMBOL	MILLIMETER			INCH		
	MIN.	NOM.	MAX.	MIN.	NOM.	MAX.
A1	0.25	0.35	0.45	0.010	0.014	0.018
A2	2.57	2.72	2.87	0.101	0.107	0.113
b	0.20	0.30	0.40	0.008	0.012	0.016
c	0.10	0.15	0.20	0.004	0.006	0.008
D	13.90	14.00	14.10	0.547	0.551	0.555
E	19.90	20.00	20.10	0.783	0.787	0.791
e		0.65			0.026	
Hd	17.00	17.20	17.40	0.669	0.677	0.685
He	23.00	23.20	23.40	0.905	0.913	0.921
L	0.65	0.80	0.95	0.025	0.031	0.037
L1		1.60			0.063	
Y			0.08			0.003
⊕	0		7	0		7

Dwg. No.:	AS100PQFP-001	
Dwg. Rev.:	A0	Unit: MM / INCH

# 82C931

Figure 7-2 100-pin TQFP, Thin Quad Flat Package

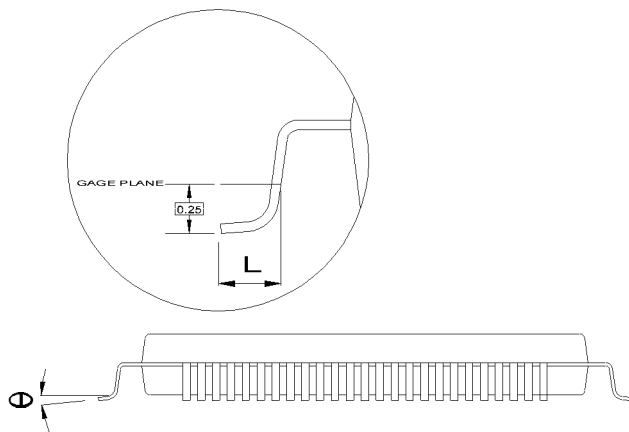
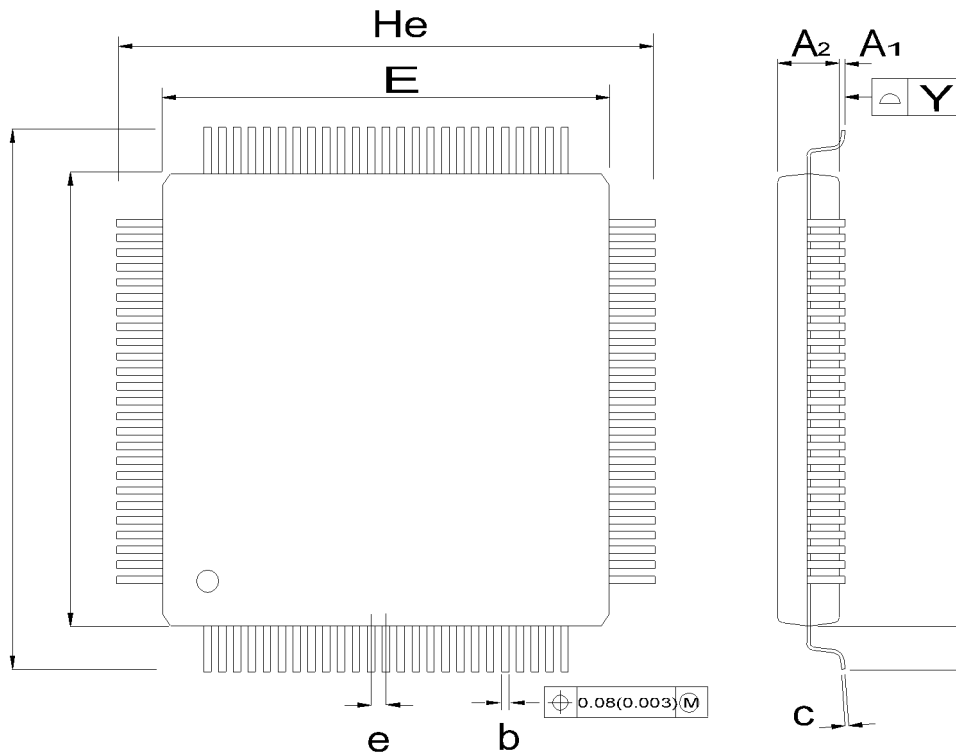

SYMBOL	MILLIMETER			INCH		
	MIN.	NOM.	MAX.	MIN.	NOM.	MAX.
A <sub>1</sub>	0.05	0.10	0.15	0.002	0.004	0.006
A <sub>2</sub>	1.35	1.40	1.45	0.053	0.055	0.057
b	0.17	0.22	0.27	0.007	0.009	0.011
c	0.090		0.200	0.004		0.008
D	13.90	14.00	14.10	0.547	0.551	0.555
E	13.90	14.00	14.10	0.547	0.551	0.555
e		0.50			0.020	
H <sub>d</sub>	15.90	16.00	16.10	0.626	0.630	0.634
H <sub>e</sub>	15.90	16.00	16.10	0.626	0.630	0.634
L	0.45	0.60	0.75	0.018	0.024	0.030
L <sub>1</sub>		1.00			0.039	
Y			0.08			0.003
θ	0		7	0		7

Dwg. No.:	AS100TQFP-001	
Dwg. Rev.:	A0	Unit: MM / INCH

**Note:** Pinout for TQFP package is identical to pinout of PQFP package.



## HEADQUARTERS:

**OPTi Inc.**  
888 Tasman Drive  
Milpitas, CA 95035  
tel: 408-486-8000  
fax: 408-486-8011

## SALES OFFICES:

### Japan

**OPTi Japan KK**  
Murata Building 6F, 2-22-7  
Ohhashi Meguro-ku  
Tokyo 153, Japan  
tel: 81-3-5454-0178  
fax: 81-3-5454-0168

### Taiwan

**OPTi Inc.**  
9F, No 303, Sec 4, Hsin Yih Road  
Taipei, Taiwan, ROC  
tel: 886-2-325-8520  
fax: 886-2-325-6520

### United States

**OPTi Inc.**  
20405 State Highway 249, Ste. #220  
Houston, TX 77070  
tel: 281-257-1856  
fax: 281-257-1825

## REPRESENTATIVES:

### United States

#### Alabama/Mississippi

**Concord Component Reps**  
190 Line Quarry Rd., Ste. #102  
Madison, AL 35758  
tel: 205-772-8883  
fax: 205-772-8262

#### Florida

**Engineered Solutions Ind., Inc.**  
1000 E. Atlantic Blvd., Ste. #202  
Pompano Beach, FL 33060  
tel: 305-784-0078  
fax: 305-781-7722

#### Georgia

**Concord Component Reps**  
6825 Jimmy Carter Blvd., Ste. #1303  
Norcross, GA 30071  
tel: 770-416-9597  
fax: 770-441-0790

#### Illinois

**Micro-Tex, Inc.**  
1870 North Roselle Rd., Ste. #107  
Schaumburg, IL 60195-3100  
tel: 708-885-8200  
fax: 708-885-8210

#### Massachusetts

**S-J Associates, Inc.**  
267 Boston Road  
Corporate Place, Ste. #3  
N. Billerica, MA 01862  
tel: 508-670-8899  
fax: 508-670-8711

### Michigan

**Jay Marketing**  
44752 Helm Street., Ste. A  
Plymouth, MI 48170  
tel: 313-459-1200  
fax: 313-459-1697

### New Jersey

S-J Associates, Inc.  
131-D Gaither Dr.  
Mt. Laurel, NJ 08054  
tel: 609-866-1234  
fax: 609-866-8627

### New York

**S-J Associates, Inc.**  
265 Sunrise Highway  
Rockville Centre, NY 11570  
tel: 516-536-4242  
fax: 516-536-9638

### S-J Associates, Inc.

735 Victor-Pittsford  
Victor, NY 14564  
tel: 716-924-1720

### North & South Carolina

**Concord Component Reps**  
10608 Dunhill Terrace  
Raleigh, NC 27615  
tel: 919-846-3441  
fax: 919-846-3401

### Ohio/W. Pennsylvania

**Lyons Corp.**  
4812 Fredrick Rd., Ste. #101  
Dayton, OH 45414  
tel: 513-278-0714  
fax: 513-278-3609

### Lyons Corp.

4615 W. Streetsboro  
Richfield, OH 44286  
tel: 216-659-9224  
fax: 216-659-9227

### Lyons Corp.

248 N. State St.  
Westerville, OH 43081  
tel: 614-895-1447  
fax: Same

### Texas

**Axxis Technology Marketing, Inc.**  
701 Brazos, Suite 500  
Austin, TX 78701  
tel: 512-320-9130  
fax: 512-320-5730

### Axxis Technology Marketing, Inc.

6804 Ashmont Drive  
Plano, TX 75023  
tel: 214-491-3577  
fax: 214-491-2508

### Virginia

**S-J Associates, Inc.**  
900 S. Washington St., Ste. #307  
Falls Church, VA 22046  
tel: 703-533-2233  
fax: 703-533-2236

### Wisconsin

**Micro-Tex, Inc.**  
22660 Broadway, Ste. #4A  
Waukesha, WI 53186  
tel: 414-542-5352  
fax: 414-542-7934

## International

### Australia

**Braemac Pty. Ltd.**  
Unit 6, 111 Moore St., Leichhardt  
Sydney, 2040 Australia  
tel: 61-2-550-6600  
fax: 61-2-550-6377

### China

**Legend Electronic Components. Ltd.**  
Unit 413, Hong Kong Industrial  
Technology Centre  
72 Tat Chee Avenue  
Kowloon Tong, Hong Kong  
tel: 852-2776-7708  
fax: 852-2652-2301

### France

**Tekelec Airtronic, France**  
5, Rue Carle Vernet  
92315 Sevres Cedex  
France  
tel: 33-1-46-23-24-25  
fax: 33-1-45-07-21-91

### Germany

**Kamaka**  
Rheinsrasse 22  
76870 Kandel  
Germany  
tel: 49-7275-958211  
fax: 49-7275-958220

### India

**Spectra Innovation**  
Unit S-822 Manipal Centre  
47 Dickenson Road  
Bangalore 560-042  
Karnataka, India  
tel: 91-80-558-8323/3977  
fax: 91-80-558-6872

### Israel

**Ralco Components (1994) Ltd.**  
11 Benyamini St.  
67443 Tel Aviv  
Israel  
tel: 972-3-6954126  
fax: 972-3-6951743

### Korea

**Woo Young Tech Co., Ltd.**  
5th Floor Koami Bldg  
13-31 Yoido-Dong  
Youngduengpo-Ku  
Seoul, Korea 150-010  
tel: 02-369-7099  
fax: 02-369-7091

### Singapore

**Instep Microsolutions Pte Ltd.**  
18, Tannery Lane, #05-02  
Lian Tong Building  
Singapore 347780  
tel: 65-741-7507  
fax: 65-741-1478

### South America

**Uniao Digital**  
Rua Guido Caloi  
Bloco B, Piso 3  
Sao Paulo-SP, CEP 05802-140 Brazil  
tel: 55-11-5514-3355  
fax: 55-11-5514-1088

### Switzerland

**Datacomp AG**  
Silberstrasse 10  
8953 Dietikon  
Switzerland  
tel: 41-1-740-5140  
fax: 41-1-741-3423

### United Kingdom

**Spectrum**  
2 Grange Mews,  
Station Road  
Launton, Bicester  
Oxfordshire, OX6 ODX  
UK  
tel: 44-1869-325174  
fax: 44-1869-325175

### MMD

3 Bennet Court,  
Bennet Road  
Reading  
Berkshire, RG2 0QX  
UK  
tel: 44 1734 313232  
fax: 44 1734 313255

The information contained within this document is subject to change without notice. OPTi Inc. reserves the right to make changes in this manual at any time as well as in the products it describes, at any time without notice or obligation. OPTi Inc. assumes no responsibility for any errors contained within. In no event will OPTi Inc. be liable for any damages, direct, indirect, incidental or consequential resulting from any error, defect, or omission in this specification.

Copyright © 1997 by OPTi Inc. All rights reserved. OPTi is a trademark of OPTi Incorporated. All other brand and product names are trademarks or copyrights of their respective owners. June 27, 1997

---

**OPTi Inc.**  
888 Tasman Drive  
Milpitas, CA 95035  
Tel: (408) 486-8000  
Fax: (408) 486-8001  
[www.opti.com](http://www.opti.com)

---