

T1/CEPT/ISDN-PRI TRANSFORMERS

Quad Port SMT Transformer Modules with IC Side Protection

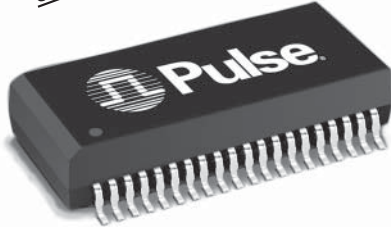

- RoHS peak reflow temperature rating 245°C
- Eight transformers in a low profile surface mount package
- Includes IC Side Protection Circuit on each channel to suppress low voltage transients
- Compatible with PMC-Sierra's Comet chip (PM4354)
- Extended temperature range
- Minimum Isolation voltage: 1500 VRMS
- UL recognized

Electrical Specifications @ 25°C — Operating Temperature -40°C to +85°C

RoHS Compliant Part Number	Turns Ratio (Pri:Sec ±2%)		OCL Lineside (mH MIN)	Cw/w (pF MAX)	LL (µH MAX)	DCR (Ω MAX)
	Transmit	Receive				
TX1299NL	1:2.42	1:2.42	1.2	25 & 25	.50 & .50	.70 & .50

Note: When ordering Tape & Reel packaging, add a "T" suffix at the end of the part number, e.g. TX1299NLT.

Mechanical

Schematic

QTERA

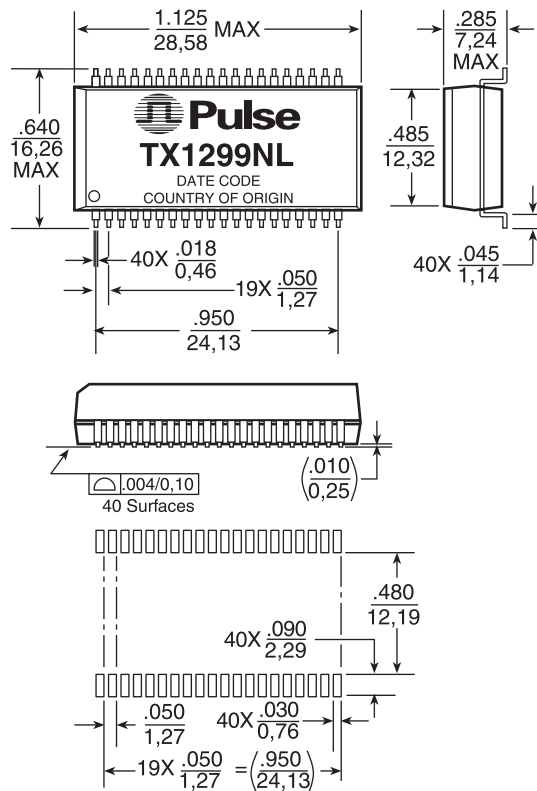

SUGGESTED PAD LAYOUT

TX1299NL

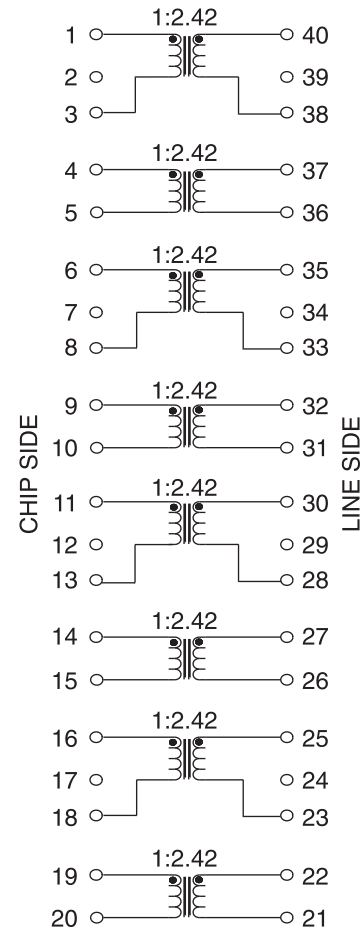

Weight 5.0 grams
Tape & Reel 250/reel
Tube 15/tube

Dimensions: Inches / mm
Unless otherwise specified, all tolerances are ± .010 / 0,25

USA 858 674 8100 • Germany 49 7032 7806 0 • Singapore 65 6287 8998 • Shanghai 86 21 62787060 • China 86 755 33966678 • Taiwan 886 3 4356823

T1/CEPT/ISDN-PRI TRANSFORMERS

Quad Port SMT Transformer Modules with IC Side Protection



Application Notes

- ET Product:** All coils have an ET product of 10 V- μ sec minimum.
- Flammability:** Materials used in the products are recognized as UL94-VO approved. Products meet the requirements of IEC 695-2-2 (Needle Flame Test).
- Balance Characteristics:** The transformers meet the requirements for longitudinal balance of FCC part 68.
- Common Mode Rejection Ratio:** The CMRR for all transformers is better than 50 dB at 1 MHz. A typical test circuit is shown below.

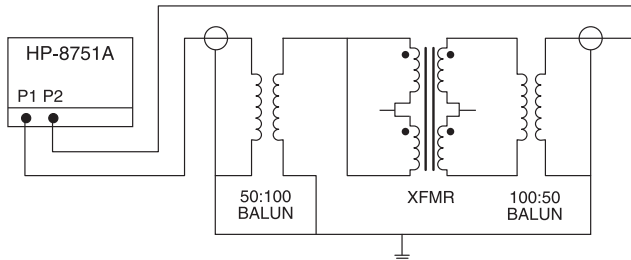

- Crosstalk Attenuation:** In the dual packages, which contain transmit and receive transformers side-by-side, sufficient crosstalk attenuation is achieved by the inherent characteristics of the toroid cores as well as by their proper positioning. The crosstalk attenuation is typically 50 dB or better from 100 KHz to 10 MHz. This result was established with the test circuit shown below.

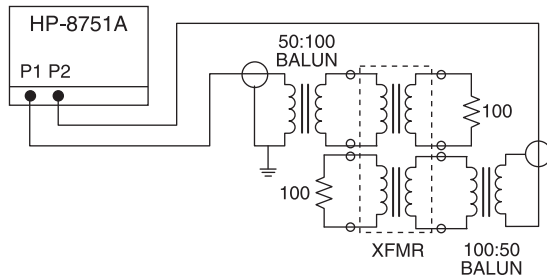

- Return Loss:** ITU-T G.703 and European national regulatory documents specify minimum return loss levels. The transformers will allow these limits to be complied within the situations where they are applicable.

Frequency	50-100 KHz	100 KHz-2 MHz	2-3 MHz
Return Loss			
XMIT	9 dB	15 dB	11 dB
REC	12 dB	18 dB	14 dB

- Surge Voltage Capability:** All transformers and chokes meet surge voltage tests according to the most stringent regulatory documents when system designs include the proper voltage and current suppression devices:

Metallic Voltage: 800 V peak, 10/560 μ sec
 Longitudinal Voltage: 2,400 V peak, 10/700 μ sec

- Isolation Voltage:** 100% of transformers are tested during production to the specified isolation voltage level.
- General Information:** These transformers are specifically designed for use in 1.544 Mbps (T1), 2.048 Mbps (CEPT) and ISDN Primary rate (PRI) interface applications. Use of the proper transformer allows the interface circuit to comply with ITU-T G.703 and other standards regarding pulse waveform, return loss, and balance.

For More Information:

Pulse Worldwide Headquarters

12220 World Trade Dr.
 San Diego, CA 92128
 U.S.A.

www.pulseeng.com

Tel: 858 674 8100
 Fax: 858 674 8262

Pulse Europe

Einsteinstrasse 1
 D-71083 Herrenberg
 Germany

Tel: 49 7032 7806 0

Fax: 49 7032 7806 135

Pulse China Headquarters

B402, Shenzhen Academy of
 Aerospace Technology Bldg.
 10th Kejinan Rd.
 High-Tech Zone
 Nanshan District
 Shenzhen, PR China 518057

Tel: 86 755 33966678

Fax: 86 755 33966700

Pulse North China

Room 2704/2705
 Super Ocean Finance Ctr.
 2067 Yan An Rd. West
 Shanghai 200336
 China

Tel: 86 21 62787060

Fax: 86 2162786973

Pulse South Asia

135 Joo Seng Rd.
 #03-02
 PM Industrial Bldg.
 Singapore 368363

Tel: 65 6287 8998

Fax: 65 6287 8998

Pulse North Asia

3F, No. 198
 Zhongyuan Rd.
 Zhongli City
 Taoyuan County 320
 Taiwan R. O. C.

Tel: 886 3 4356768

Fax: FRE 886 3 4356820

Pulse: 886 3 4356823

Performance warranty of products offered on this data sheet is limited to the parameters specified. Data is subject to change without notice. Other brand and product names mentioned herein may be trademarks or registered trademarks of their respective owners.

© Copyright, 2009. Pulse Engineering, Inc. All rights reserved.

www.pulseeng.com

T677.C (10/09)