

### DESCRIPTIONS

The IP3101 provides simple and high performance control functions for the half bridge L/C resonant system, specially electronic ballast. It internally integrated the essential functions of the half bridge L/C resonant system so the conventional system can be realized a minimum board area, small external components and low power dissipation.

Internally integrated soft-start circuit eliminated the need for external soft-start circuit. And the initial pre-heating switching frequency and preheating time can be easily programmable with only one capacitor (preheating frequency capacitor) and one resistor (preheating time capacitor) depending on the types of lamps. Also the normal operating frequency can be easily adjusted by timing resistor (Rt) and timing capacitor (Ct).

The cold cathode current can be limited by changing the normal operating frequency to soft-start frequency with an external small signal transistor. No lamp protection or any required protection like over current protection can be realized by adding an external small signal transistor.

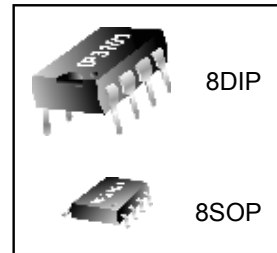

### FEATURES

- Internal Soft Start
- Programmable Soft Start Frequency
- Programmable Preheating Time
- Very Precision Internal Operating Frequency( $\pm 5\%$ )
- No Lamp Protection or Over Current Protection
- Precision Internal Reference Voltage
- 8DIP, 8SOP Packages

### ORDER INFORMATIONS

Device	Package	Operating Temp
IP3101	8DIP	-25 °C ~ 125 °C
I3101	8SOP	

### BLOCK DIAGRAM

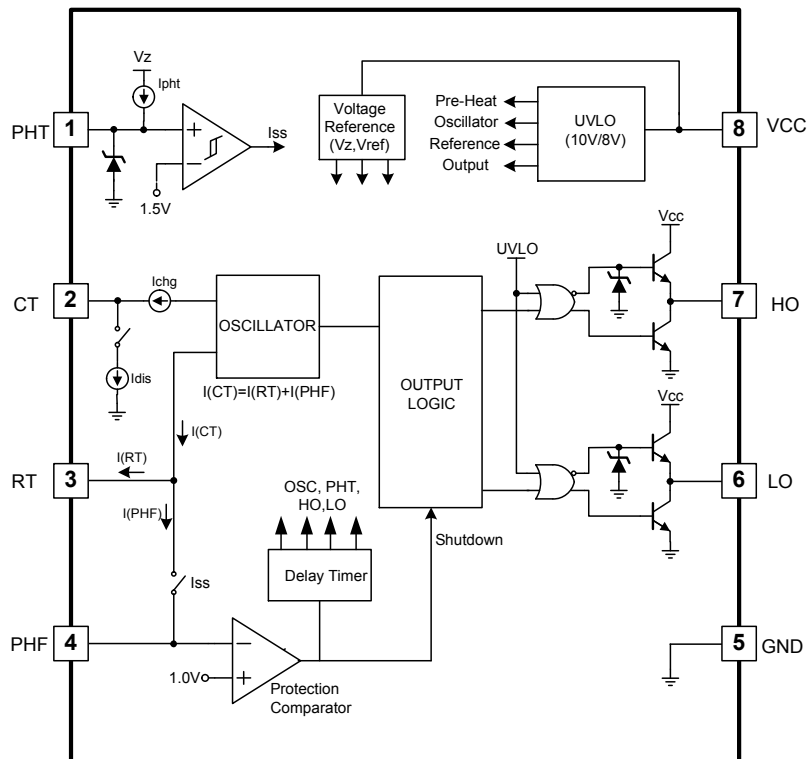

### PIN CONNECTIONS

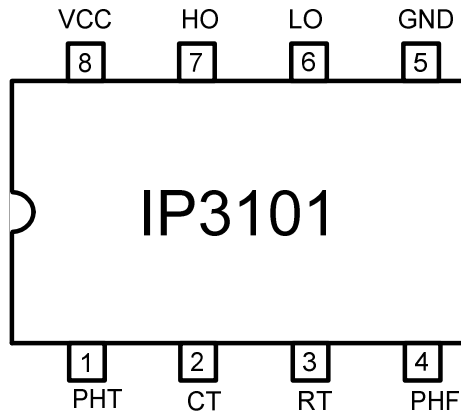

### PIN DESCRIPTIONS

NO	SYMBOL	I/O	DESCRIPTION
1	PHT	I	Preheating Time & Soft-start Time Control Pin with Capacitor
2	CT	I	Internal Oscillator Timing Control Pin with Capacitor
3	RT	I	Internal Oscillator Timing Control Pin with Resister
4	PHF	I	Preheating Frequency & Soft-Start Frequency Control Pin with Resister
5	GND	-	Ground
6	LO	O	Low Side Gate Drive Output
7	HO	O	High Side Gate Drive Output
8	VCC	-	Supply Voltage

### ABSOLUTE MAXIMUM RATINGS

CHARACTERISTICS	SYMBOL	VALUE	UNIT
Maximum Supply Voltage	VCCMAX	30	V
Maximum Operating Supply Voltage	VOPMAX	24	V
Totem-pole Output Peak Current	IPEAK	300	±mA
Power Dissipation(8DIP)	Pd	800	mW
PIN1,2,3,4 Voltage	VIN	-0.4 ~ 6	V
Output Clamp Diode Current	ICLAMP	30	mA
Operating Junction Temperature	Tj	-25 ~ +125	°C
Storage Temperature	Tstg	-65 ~ 150	°C

### ELECTRICAL CHARACTERISTICS

(Ta = 25 °C, Vcc=14V, fosc=46KHz, unless otherwise specified.)

CHARACTERISTICS	SYMBOL	CONDITIONS	MIN	TYP	MAX	UNIT
<b>Total Supply Current Section</b>						
Start-up Current	IST	Vcc = 9V	-	125	250	uA
Quiescent Current	IQ	Not Switching	3	7.5	12	mA
Operating Supply Current	ICC	fosc=46KHz, Co=1nF	4	9	14	mA
<b>Under Voltage Lock Output Section</b>						
Vcc Turn-On Voltage	VCCON	Vcc Increasing	9	10	11	V
UVLO Hysteresis Voltage	HYS		1.5	2	2.5	V
<b>Preheating (Soft Start) Section</b>						
PHT Charging Current	IPHT	PIN1=0V	0.7	0.9	1.1	uA
PHT Threshold Voltage	VPHT	PIN1 Increasing, Rphf=33KΩ	1.2	1.5	1.8	V
PHF Reference Voltage	VPHF	IPHF=100uA	1.95	2.00	2.05	V
PHF Reference Voltage Line Regulation	DVPHF1	Vcc=12~20V	-6	0.1	6	mV
PHF Reference Voltage Load Regulation	DVPHF2	Io=50uA~200uA	-12	-0.1	12	mV
<b>Protection Section</b>						
Protection Input Threshold Voltage	VPROT	PIN4=from 2.0V to 0V	0.7	1.0	1.3	V
Protection Triggering Cur- rent	IPROT	PIN4=0V	-	-1	-	mA
PHF Maximum Current	IPHF	VPHF=1.5V	200	-	-	uA

### ELECTRICAL CHARACTERISTICS (Continued)

CHARACTERISTICS	SYMBOL	CONDITIONS	MIN	TYP	MAX	UNIT
<b>Oscillator Section</b>						
RT Reference Voltage	VRT	IRT=100uA	1.95	2.00	2.05	V
RT Short to GND Current	ISCRT	PIN3=0V	1	2	-	mA
RT Reference Line Regulation	DVRT1	Vcc=12V~20V	-6	0.1	6	mV
RT Reference Load Regulation	DVRT2	Io=100uA~500uA	-12	-0.1	12	mV
Soft Start Output Frequency	FPHT11	PIN1=0V, Rphf=33KΩ, CT=470pF, RT=20KΩ	61	68	75	KHz
Operating Frequency <sup>NOTE</sup>	FOSC1	PIN1=5V, Rphf=33KΩ, CT=470pF, RT=20KΩ	43	46	49	kHz
Frequency Variation With Vcc	DVFSC1	Vcc=14V~24V	-	0.01	-	%
Dead Time	TD	PIN1=5V, Rphf=33KΩ, CT=470pF, RT=20KΩ	1.15	1.75	2.35	us
<b>Output Section</b>						
Output High Voltage 11	VOH11	Io = -10mA	11	12	13	V
Output High Voltage 12	VOH12	Io = -100mA	10.5	11.5	12.5	V
Output Low Voltage 21	VOL21	Io = 10mA	0	0.05	0.4	V
Output Low Voltage 22	VOL22	Io = 100mA	0.05	0.4	1.2	V
Output Maximum Voltage	VHOMAX	Vcc=20V, No Load	11	14	17	V
Output Voltage with UVLO activated	VUV	Vcc=5V, Io=100uA	-	0.6	1	V

\* NOTE : FOSC (Operating Frequency) is the half of Oscillator Frequency.

## APPLICATION INFORMATIONS

### 1. Calculation for $V_{PHT}$

The  $V_{PHT}$  is voltage of pin 1. The preheating time is decided by this voltage.

$$V_{PHT} = \frac{44000}{R_{PHF}} + 0.05$$

Where,

$R_{PHF}$  is the value of resistor which is connected to pin 4.

### 2. Calculation for $T_{PH}$

The  $T_{PH}$  is preheating time, from preheating frequency to normal operating frequency. When the voltage of pin 1 reach to the  $V_{PHT}$ , the preheating will be completed.

$$T_{PH} = \frac{C_{PHT}}{0.9 \cdot 10^{-6}} \times V_{PHT}$$

Where,

$C_{PHT}$  is the value of capacitor which is connected to pin 1.

### 3. Calculation for $f_{SW}$

The  $f_{SW}$  is normal operating frequency.

$$f_{SW} \cong \frac{1}{2.2 \cdot R_T C_T}$$

Where,

$C_T$  &  $R_T$  are the value of capacitor & resistor which are connected to pin 2 & pin 3.

### 4. Calculation for $f_{PRH}$

The  $f_{PRH}$  is preheating frequency.

$$f_{PRH} \cong \frac{R_T + R_{PHF}}{2.5 \cdot R_T C_T R_{PHF}}$$

**OPERATION TIMING CHART**

**TEST CONDITION**

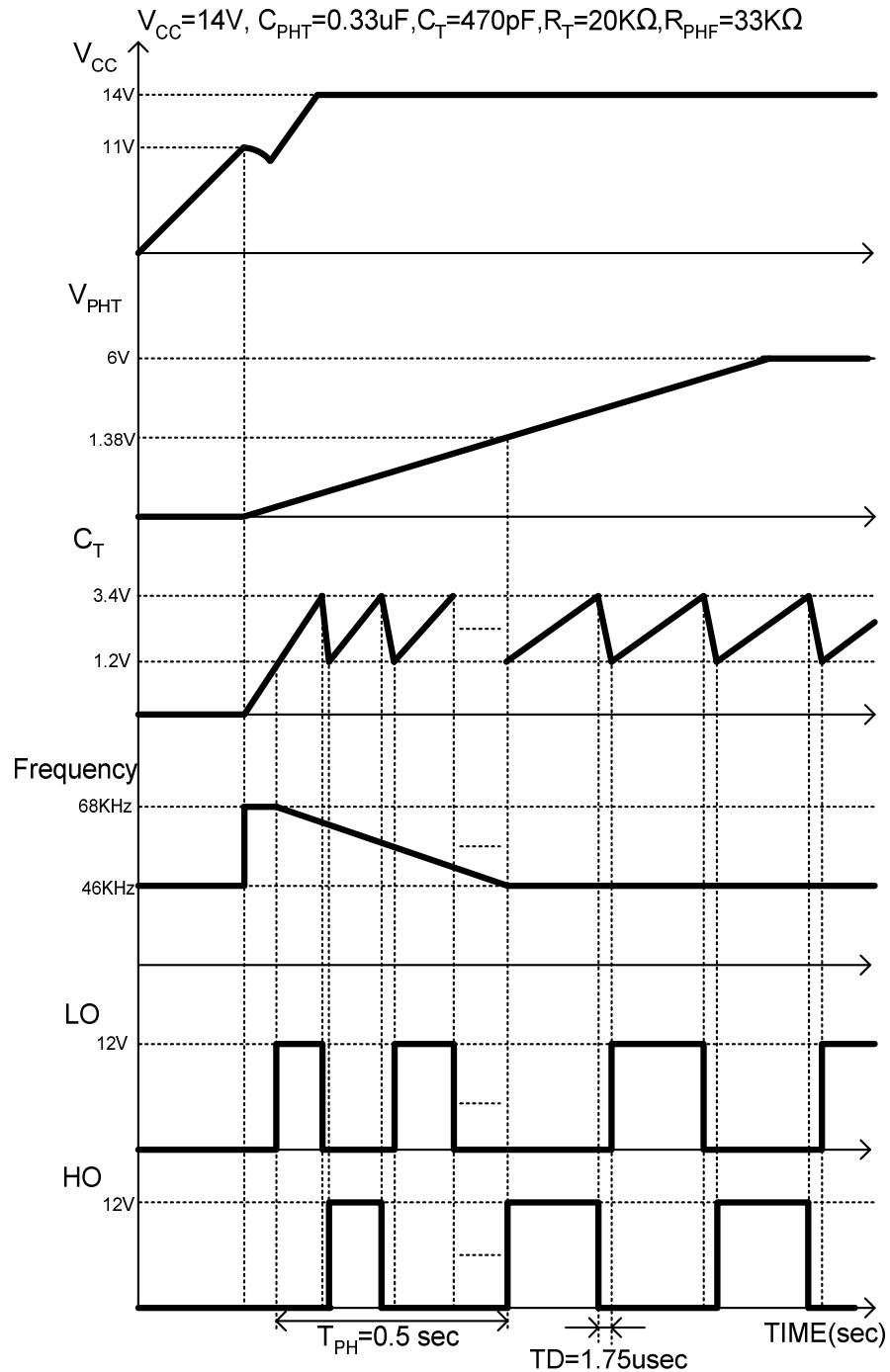

**TEST CIRCUITS**

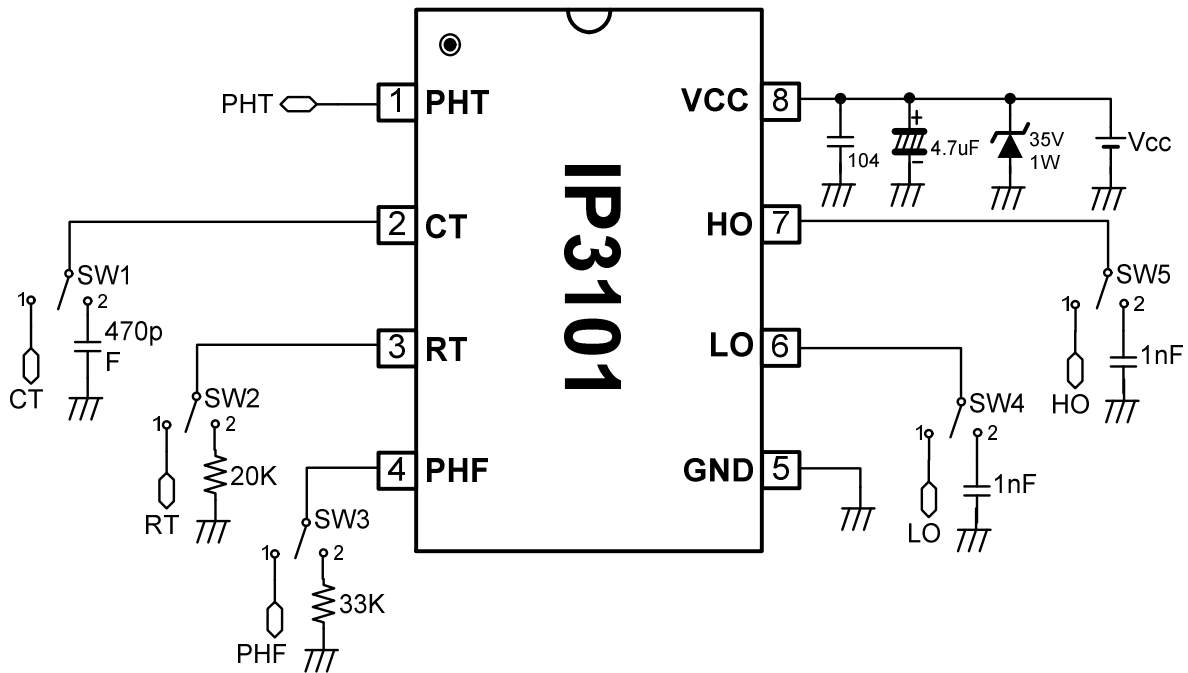

**TYPICAL APPLICATION CIRCUITS**

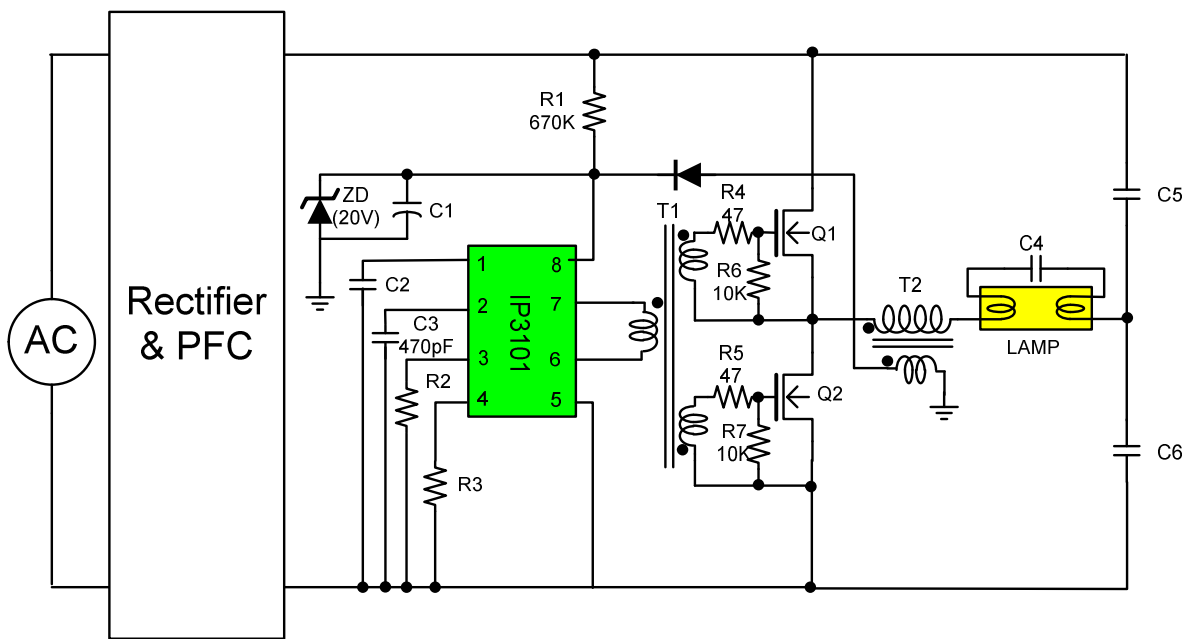

**PACKAGE DIMENSIONS**

**8-DIP**

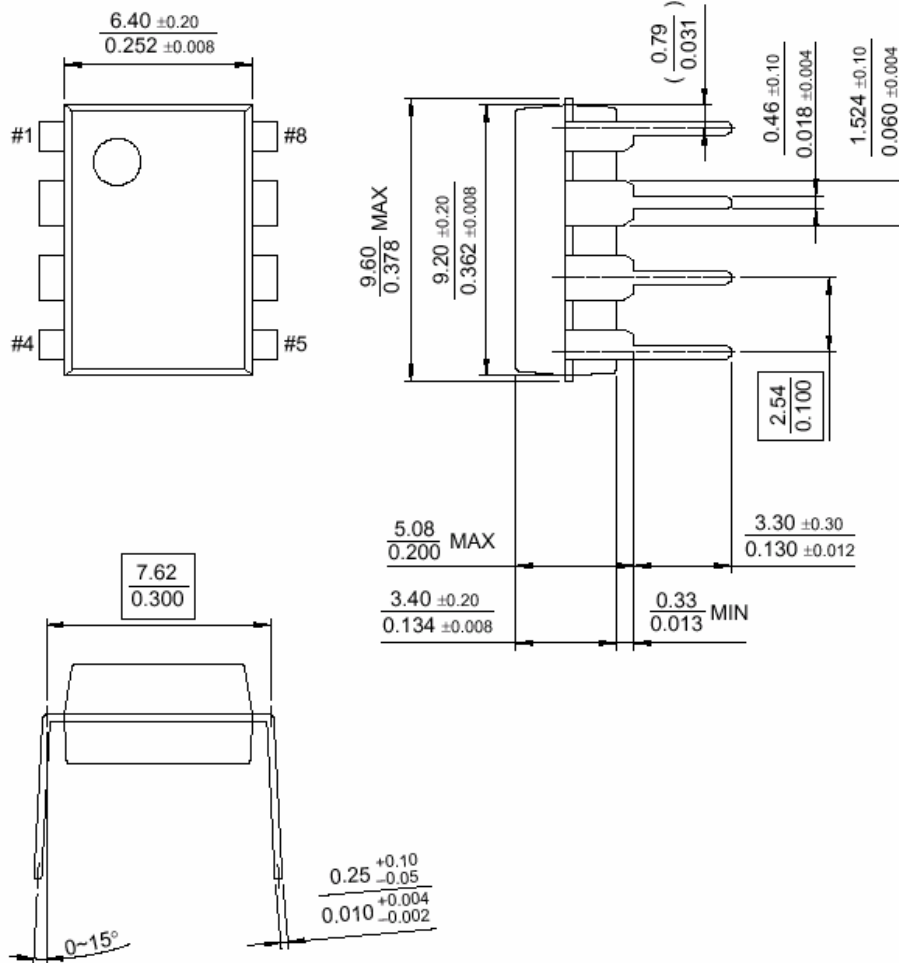



**PACKAGE DIMENSIONS**

**8-SOP**

